

**FM IF SYSTEM FOR CAR RADIOS**

The KA2244 is a monolithic integrated circuit consisting of FM IF amplifier, detector, muting circuit and signal meter driver. It is suitable for car radios.

**FUNCTIONS**

- 3-stage IF amplifiers.
- Peak detector.
- Muting circuit.
- Signal meter drive circuit.

**FEATURES**

- Suitable for FM car radios.
- Wide operating supply voltage range:  $V_{CC} = 8V - 15V$
- High detector output voltage ( $V_o = 500mV$ , Typ).
- Variable muting level.
- Muting off by Pin 4 open.
- Simplified single coil tuning.
- Low distortion (THD=0.1%; Typ).
- Minimum number of external parts required.

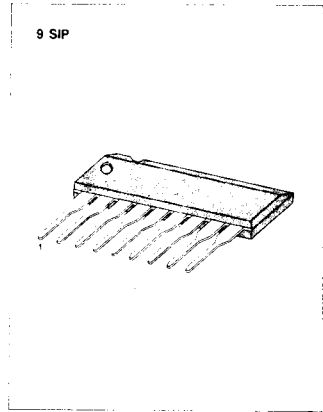

**ORDERING INFORMATION**

Device	Package	Operating Temperature
KA2244	9 SIP	-20°C ~ +70°C

**BLOCK DIAGRAM**

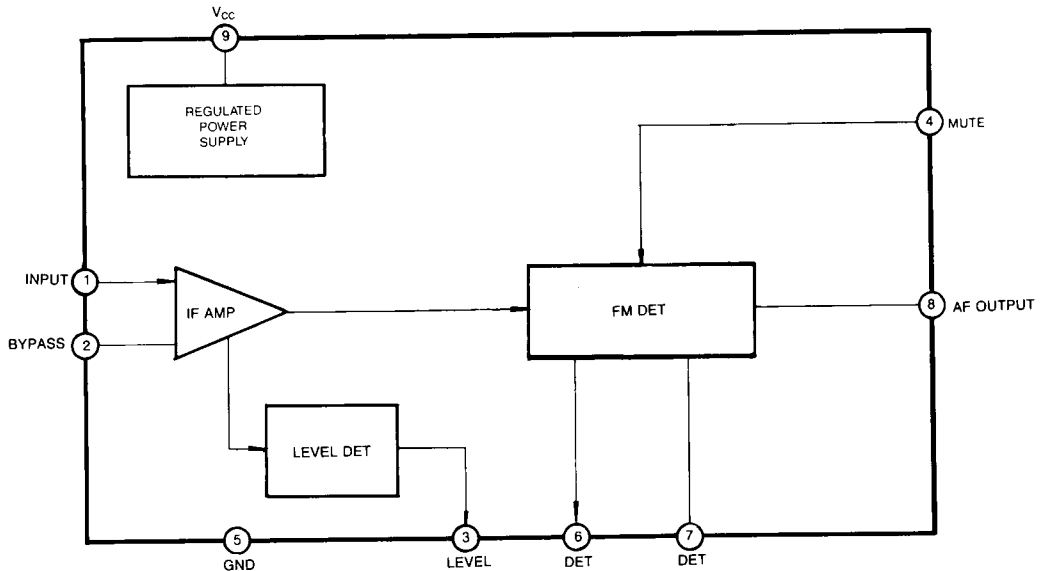

Fig. 1

ABSOLUTE MAXIMUM RATINGS (T<sub>a</sub> = 25°C)

Characteristic	Symbol	Value	Unit
Supply Voltage	V <sub>CC</sub>	16	V
Input Voltage	V <sub>I</sub>	0.7	V
Power Dissipation	P <sub>D</sub>	750	mW
Operating Temperature	T <sub>OPR</sub>	-20 ~ +70	°C
Storage Temperature	T <sub>STG</sub>	-40 ~ +125	°C

\*: Derated above T<sub>a</sub> = 25°C in the proportion of 4mW/°C

## ELECTRICAL CHARACTERISTICS

(T<sub>a</sub> = 25°C, V<sub>CC</sub> = 12V, f = 10.7MHz, f<sub>m</sub> = 400Hz, unless otherwise specified)

Characteristic	Symbol	Test Conditions	Min	Typ	Max	Unit
Quiescent Circuit Current	I <sub>CCQ</sub>	V <sub>I</sub> = 0	10	14	18	mA
-3dB Limiting Sensitivity	V <sub>I(LIM)</sub>	-3dB point from V <sub>O</sub> (V <sub>I</sub> = 80dB <sub>μ</sub> , Δf = ±75KHz)		50	55	dB <sub>μ</sub>
AM Rejection Ratio	AMR	FM: Δf = ±75KHz dev AM: 30% Mod, f <sub>m</sub> = 1KHz V <sub>I</sub> = 80dB <sub>μ</sub>		50		dB
Detector Output Voltage	V <sub>O(DET)</sub>	Δf = ±75KHz dev V <sub>I</sub> = 80dB <sub>μ</sub>	300	500	700	mV
Total Harmonic Distortion	THD	Δf = ±22.5KHz dev V <sub>I</sub> = 80dB <sub>μ</sub>		0.1		%
Signal to Noise Ratio	S/N	Δf = ±75KHz dev V <sub>I</sub> = 80dB <sub>μ</sub>		75		dB
Muting Attenuation	ATT <sub>MUTE</sub>	Δf = ±75KHz dev V <sub>I</sub> = 80dB <sub>μ</sub> , V <sub>I</sub> = 0		70		dB
Meter Driver Voltage	V <sub>M</sub>	V <sub>I</sub> = 110dB <sub>μ</sub>		4.0		V

TEST CIRCUIT

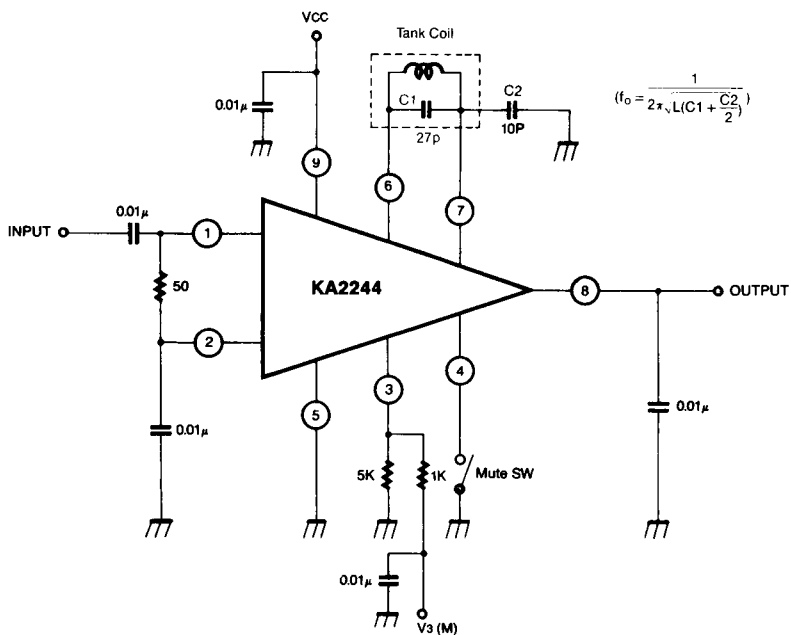
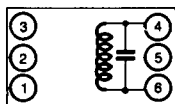

Fig. 2

COIL SPECIFICATIONS



C <sub>o</sub> (pF)	f (MHz)	Q <sub>o</sub> (%)	TURNS		
			4-6		
27	10.7	150	18		

Seoul Jupa SJ-59JG-045 0.1mmφ UEW

OUTPUT VOLTAGE  
SIGNAL TO NOISE RATIO — INPUT VOLTAGE  
AM REJECTION RATIO

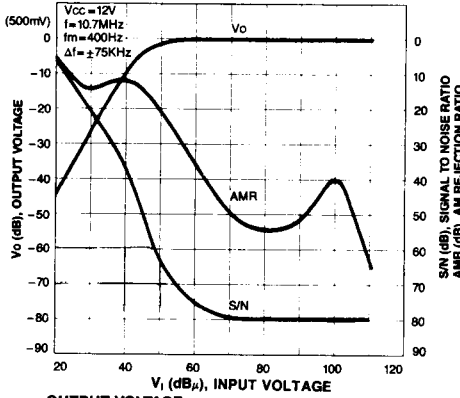

OUTPUT VOLTAGE .  
TOTAL HARMONIC DISTORTION — FREQUENCY  
DEVIATION

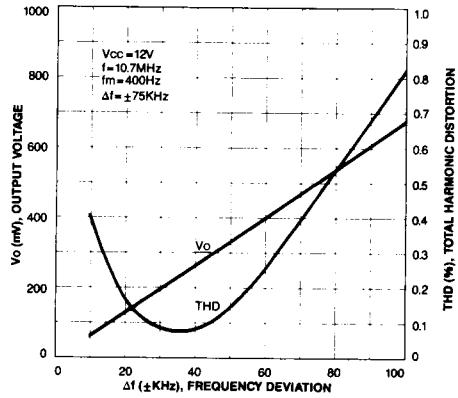

OUTPUT VOLTAGE  
TOTAL HARMONIC DISTORTION — SUPPLY VOLTAGE  
SIGNAL TO NOISE RATIO

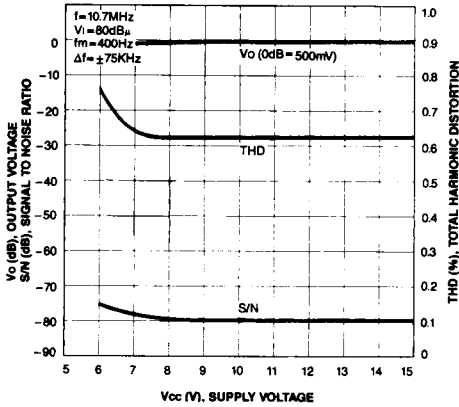

OUTPUT VOLTAGE-MODULATION FREQUENCY

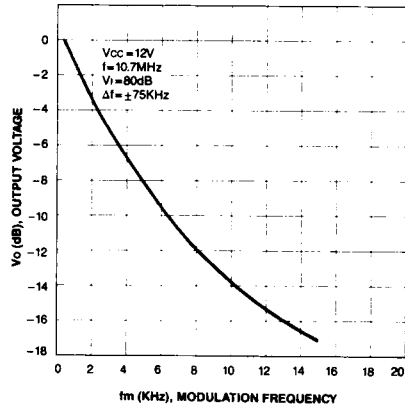

MUTING ATTENUATION-MUTE DRIVE VOLTAGE

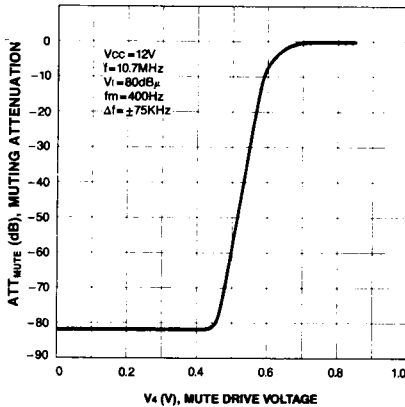

OUTPUT DC VOLTAGE-INPUT FREQUENCY

