

SANYO Semiconductors

DATA SHEET

An ON Semiconductor Company

Bi-CMOS LSI

LV8702V — PWM Current Control High-efficient Stepping Motor Driver

Overview

The LV8702V is a 2-channel Full-bridge driver IC that can drive a stepping motor driver, which is capable of micro-step drive and supports quarter step. Current is controlled according to motor load and rotational speed at half step, half step full-torque and quarter step excitation, thereby highly efficient drive is realized. Consequently, the reduction of power consumption, heat generation, vibration and noise is achieved.

Features

- Built-in 1ch PWM current control stepping motor driver (bipolar type)
- Ron (High-side Ron: 0.3Ω, Low-side Ron: 0.25Ω, total: 0.55Ω, Ta = 25°C, IO = 2.5A)
- Excitation mode is configurable as follows: full step/half step full-torque/half step/quarter step
- Excitation step moves forward only with step signal input
- Built-in output short protection circuit (latch method)
- Control power supply is unnecessary
- Built-in high-efficient drive function (supports half step full-torque/half step/quarter step excitation mode)
- Built-in step-out detection function (Step-out detection may not be accurate during high speed rotation)
- BiCDMOS process IC
- IO max=2.5A
- Built-in thermal shut down circuit

Specifications

Absolute Maximum Ratings at Ta = 25°C

Parameter	Symbol	Conditions	Ratings	Unit
Power supply voltage	V _M max		36	V
Output peak current	I _O peak	tw ≤ 10ms, duty 20%	3	A
Output current	I _O max		2.5	A
Logic input voltage	V _{IN}		-0.3 to +6	V
DST1, DST2, MONI, SST pin input voltage	Vdst1, Vdst2, Vmoni, Vsst		-0.3 to +6	V
Allowable power dissipation	Pd max	Ta ≤ 25°C *	5.5	W
Operating temperature	Topr		-40 to +85	°C
Storage temperature	Tstg		-55 to +150	°C

* Specified board : 90.0mm × 90.0mm × 1.6mm, glass epoxy 4-layer board, with backside mounting.

Continued on next page.

■ Any and all SANYO Semiconductor Co.,Ltd. products described or contained herein are, with regard to "standard application", intended for the use as general electronics equipment. The products mentioned herein shall not be intended for use for any "special application" (medical equipment whose purpose is to sustain life, aerospace instrument, nuclear control device, burning appliances, transportation machine, traffic signal system, safety equipment etc.) that shall require extremely high level of reliability and can directly threaten human lives in case of failure or malfunction of the product or may cause harm to human bodies, nor shall they grant any guarantee thereof. If you should intend to use our products for new introduction or other application different from current conditions on the usage of automotive device, communication device, office equipment, industrial equipment etc. , please consult with us about usage condition (temperature, operation time etc.) prior to the intended use. If there is no consultation or inquiry before the intended use, our customer shall be solely responsible for the use.

■ Specifications of any and all SANYO Semiconductor Co.,Ltd. products described or contained herein stipulate the performance, characteristics, and functions of the described products in the independent state, and are not guarantees of the performance, characteristics, and functions of the described products as mounted in the customer's products or equipment. To verify symptoms and states that cannot be evaluated in an independent device, the customer should always evaluate and test devices mounted in the customer's products or equipment.

SANYO Semiconductor Co., Ltd.
<http://www.sanyosemi.com/en/network/>

LV8702V

Continued from preceding page.

Caution 1) Absolute maximum ratings represent the value which cannot be exceeded for any length of time.

Caution 2) Even when the device is used within the range of absolute maximum ratings, as a result of continuous usage under high temperature, high current, high voltage, or drastic temperature change, the reliability of the IC may be degraded. Please contact us for the further details.

Recommended Operating Range at Ta = 25°C

Parameter	Symbol	Conditions	Ratings	Unit
Range of power supply voltage	V _M		9 to 32	V
Logic input voltage	V _{IN}		0 to 5.5	V
Range of VREF input voltage	VREF		0 to 3	V

Electrical Characteristics at Ta = 25°C, V_M = 24V, VREF = 1.5V

Parameter	Symbol	Conditions	Ratings			Unit	
			min	typ	max		
Consumption current during standby	IMstn	ST = "L"		110	400	μA	
Consumption current	IM	ST = "H", OE = "L", STEP = "L", non-load		4.5	6.5	mA	
VREG5 output voltage	VREG5	I _O = -1mA	4.5	5	5.5	V	
Thermal shutdown temperature	TSD	Design certification	150	180	210	°C	
Thermal hysteresis width	ΔTSD	Design certification		40		°C	
Motor driver							
Output on resistor	Ronu	I _O = 2.5A, Source-side Ron		0.3	0.4	Ω	
	Rond	I _O = 2.5A, Sink-side Ron		0.25	0.33	Ω	
Output leak current	I _{Oleak}	V _M = 32V			50	μA	
Forward diode voltage	V _D	I _D = -2.5A		1.2	1.4	V	
logic pin input current	I _{INL}	V _{IN} = 0.8V	4	8	12	μA	
	I _{INH}	V _{IN} = 5V	30	50	70	μA	
ADIN pin input voltage	V _{adin}	Ra2 = 100kΩ: refer to 15-4)	0		12	V	
Logic input "H" level voltage	V _{INH}		2.0			V	
Logic input "L" level voltage	V _{INL}				0.8	V	
Current selection reference voltage level	quarter step	Vtdac0_W	Step0 (initial status, 1ch comparator level)	290	300	310	mV
		Vtdac1_W	Step1 (initial + 1)	264	276	288	mV
		Vtdac2_W	Step2 (initial + 2)	199	210	221	mV
		Vtdac3_W	Step3 (initial + 3)	106	114	122	mV
	half step	Vtdac0_H	Step0 (initial status, 1ch comparator level)	290	300	310	mV
		Vtdac2_H	Step2 (initial + 1)	199	210	221	mV
	half step (full-torque)	Vtdac0_HF	Step0 (initial status, 1ch comparator level)	290	300	310	mV
		Vtdac2'_HF	Step2' (initial + 1)	290	300	310	mV
full step	Vtdac2'_F	Step2' (initial status, 1ch comparator level)	290	300	310	mV	
Chopping frequency	Fchop	Cchop = 200pF	35	50	65	kHz	
CHOP pin charge/discharge current	I _{chop}		7	10	13	μA	
Chopping oscillator circuit threshold voltage	V _{tup}		0.8	1	1.2	V	
VREF pin input current	I _{ref}	VREF = 1.5V	-0.5			μA	
DST1, DST2, MONI, SST pin saturation voltage		I _{dst1} = I _{dst2} = I _{moni} = I _{sst} = 1mA			400	mV	
Charge pump							
VG output voltage	V _G		28	28.7	29.8	V	
Rise time	t _{ONG}	V _G = 0.1μF			0.5	mS	
Oscillator frequency	F _{osc}		90	125	160	kHz	

LV8702V

Package Dimensions

unit : mm (typ)

3285B

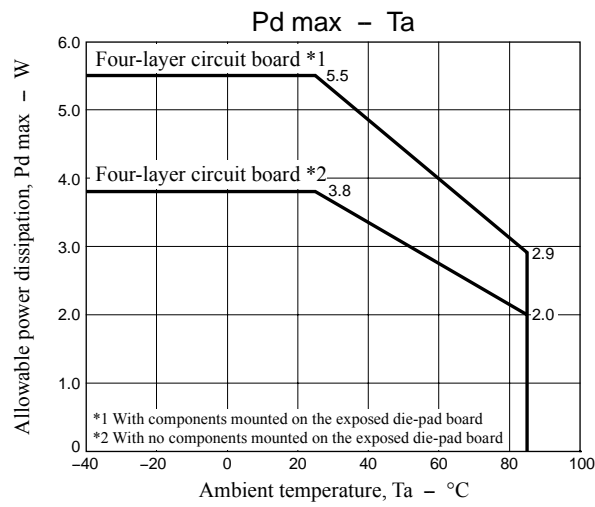
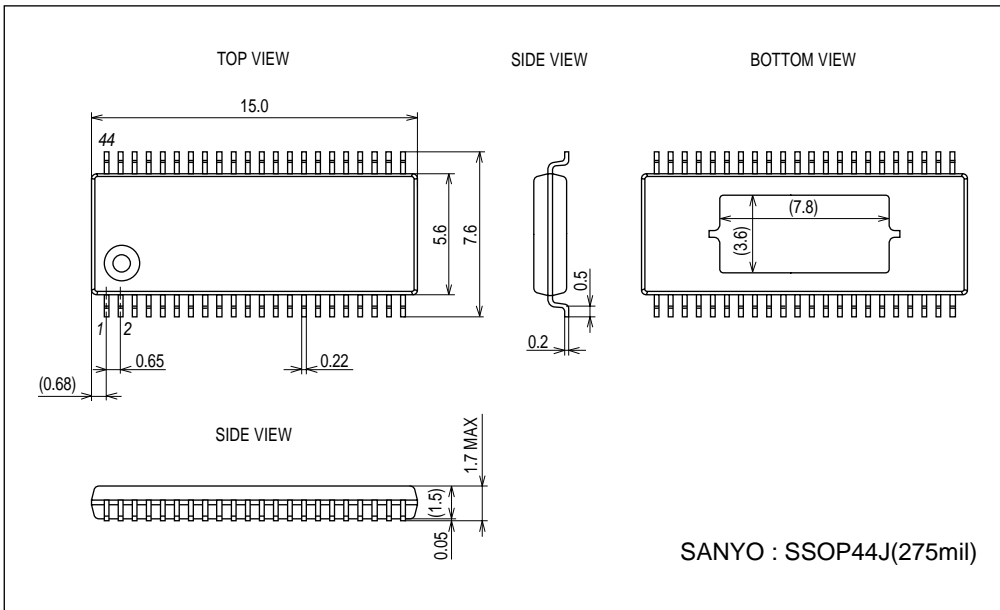

LV8702V

Substrate specifications (Substrate recommended for operation of LV8702V)

Size : 90mm × 90mm × 1.6mm (Four-layer substrate)
Material : Glass epoxy
Copper wiring density : L1 = 85%, L2 = 90%

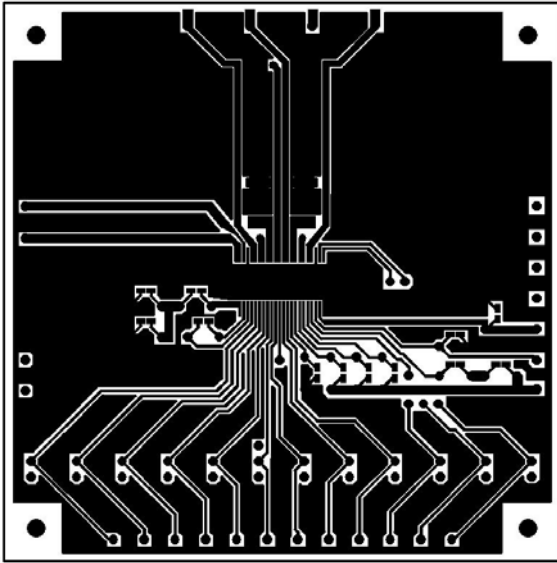

L1: Copper wiring pattern diagram

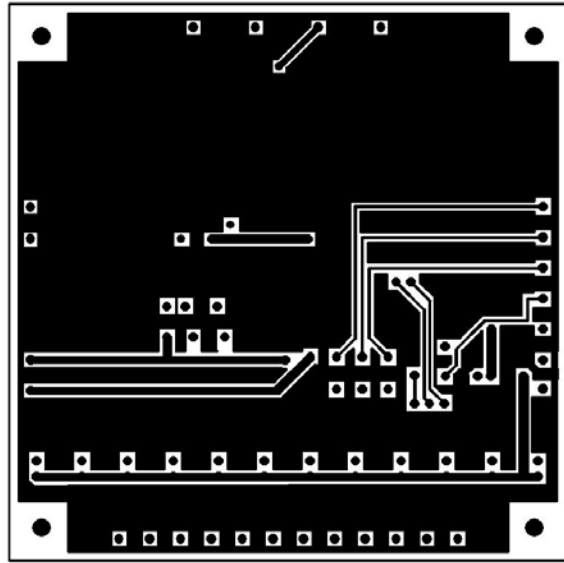

L2: Copper wiring pattern diagram

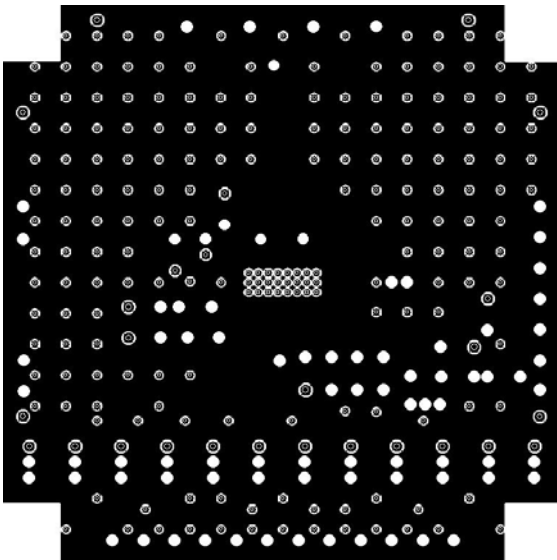

L3: GND layer

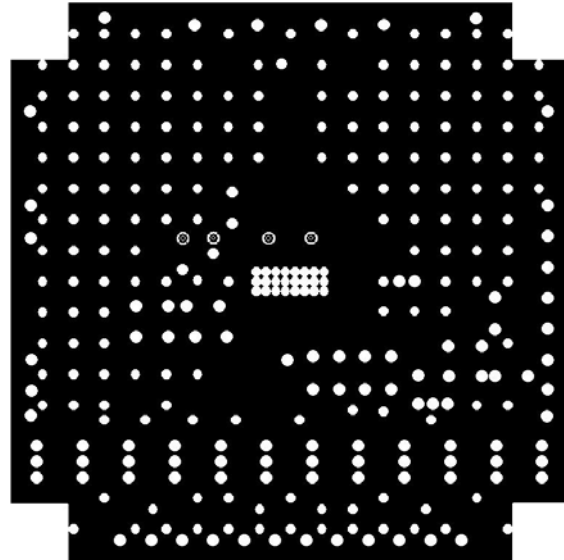

L4: Power supply layer

Cautions

- 1) The data for the case with the Exposed Die-Pad substrate mounted shows the values when 90% or more of the Exposed Die-Pad is wet.
- 2) For the set design, employ the derating design with sufficient margin.
Stresses to be derated include the voltage, current, junction temperature, power loss, and mechanical stress such as vibration, impact, and tension.
Accordingly, the design must ensure these stresses to be as low or small as possible.
The guideline for ordinary derating is shown below:
 - (1) Maximum value 80% or less for the voltage rating
 - (2) Maximum value 80% or less for the current rating
(However this does not apply to high efficiency drive because operating current is lower than the setting current.)
 - (3) Maximum value 80% or less for the temperature rating
- 3) After the set design, be sure to verify the design with the actual product.
Confirm the solder joint state and verify also the reliability of solder joint for the Exposed Die-Pad, etc.
Any void or deterioration, if observed in the solder joint of these parts, causes deteriorated thermal conduction, possibly resulting in thermal destruction of IC.

LV8702V

Pin Assignment

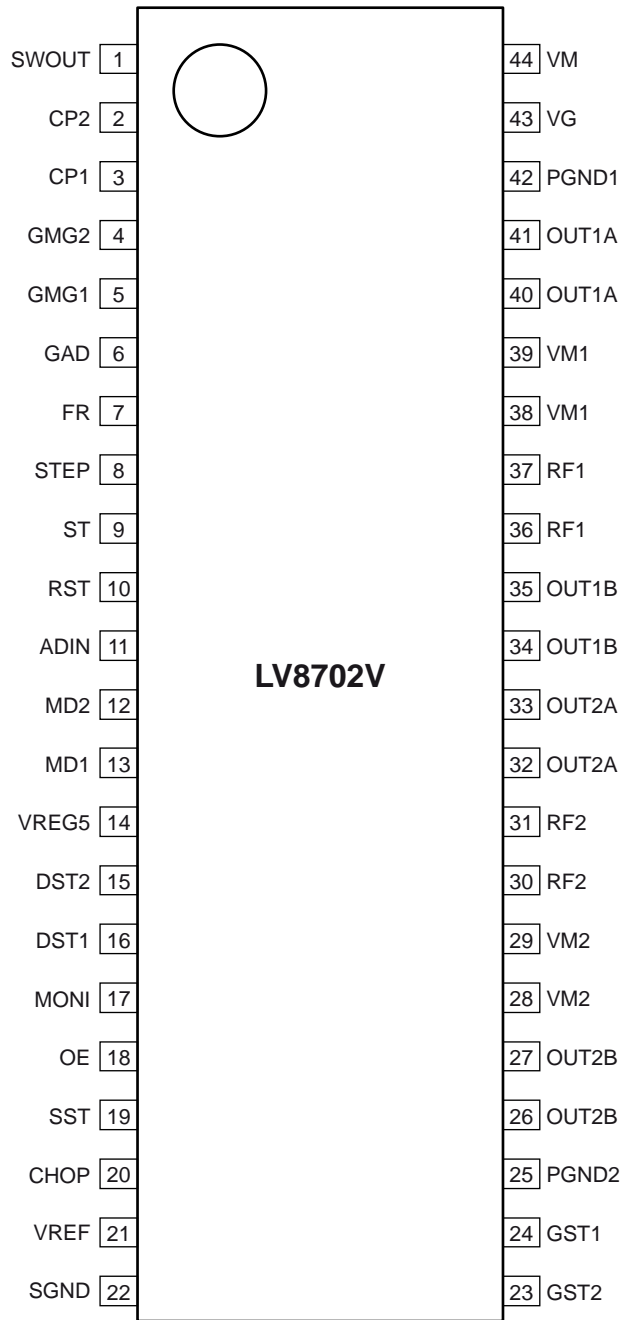

Top view

LV8702V

Block Diagram

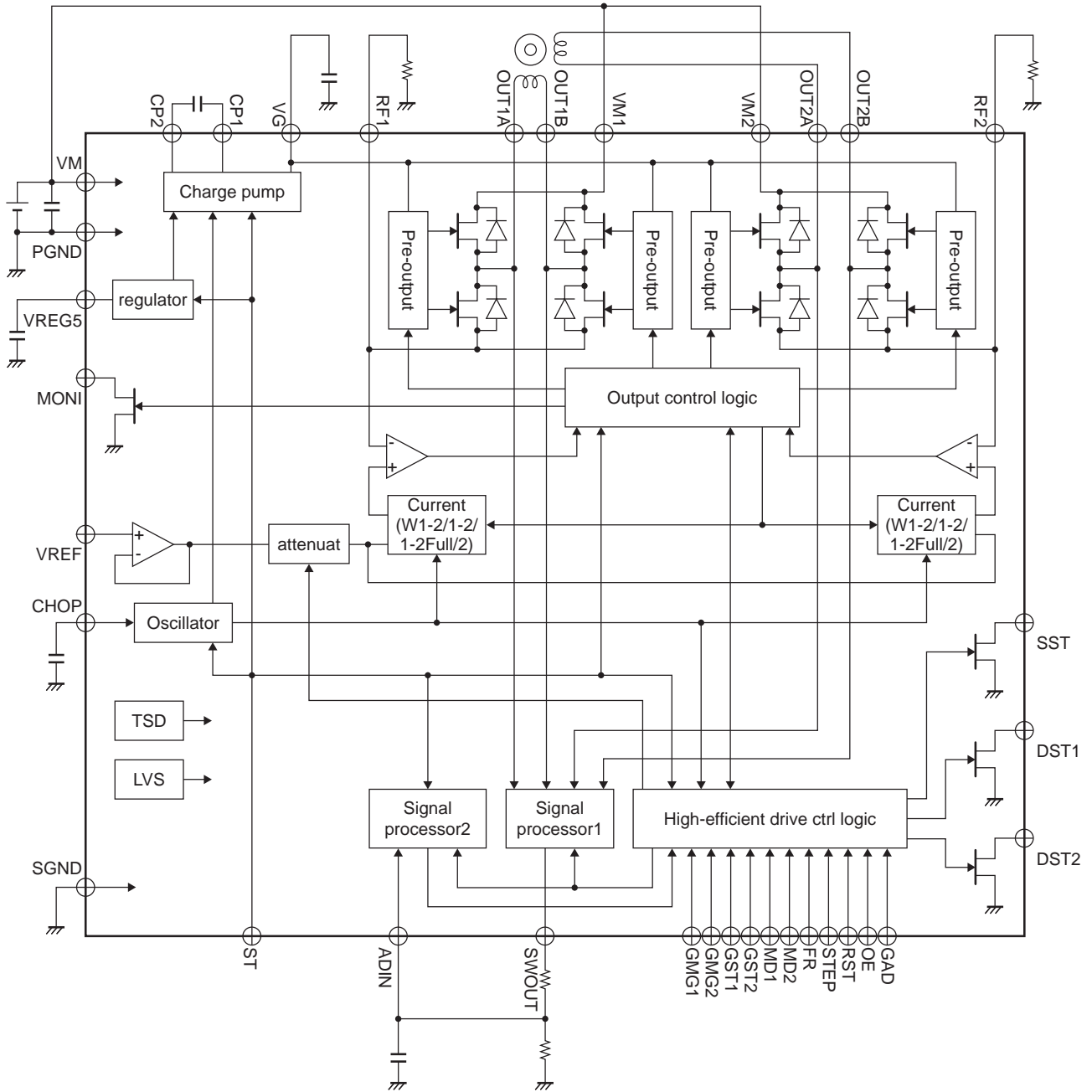

LV8702V

Pin Functions

Pin No.	Pin name	Description
1	SWOUT	Control signal output pin
2	CP2	Capacitor connection pin for charge pump
3	CP1	Capacitor connection pin for charge pump
4	GMG2	Driving capability margin adjuster pin
5	GMG1	Driving capability margin adjuster pin
6	GAD	High-efficient drive switching pin
7	FR	Forward/ reverse signal input pin
8	STEP	STEP signal input pin
9	ST	Chip enable pin
10	RST	RESET signal input pin
11	ADIN	Control signal input pin
12	MD2	Excitation mode switching pin
13	MD1	Excitation mode switching pin
14	VREG5	Capacitor connection pin for internal power supply
15	DST2	Drive status warning output pin
16	DST1	Drive status warning output pin
17	MONI	Position detection monitor pin
18	OE	Output enable signal input pin
19	SST	Motor stop detection output pin
20	CHOP	Capacitor connection pin for chopping frequency setting
21	VREF	Constant current control reference voltage input pin
22	SGND	Signal GND
23	GST2	Boost-up adjuster pin
24	GST1	Boost-up adjuster pin
25	PGND2	2ch power GND
26, 27	OUT2B	2ch OUTB output pin
28, 29	VM2	2ch motor power supply connection pin
30, 31	RF2	2ch current sense resistor connection pin
32, 33	OUT2A	2ch OUTA output pin
34, 35	OUT1B	1ch OUTB output pin
36, 37	RF1	1ch current sense resistor connection pin
38, 39	VM1	1ch motor power supply connection pin
40, 41	OUT1A	1ch OUTA output pin
42	PGND1	1ch power GND
43	VG	Capacitor connection pin for charge pump
44	VM	Motor power supply connection pin

LV8702V

Pin Description

Pin No.	Pin name	Equivalent Circuit
4 5 6 7 8 10 12 13 18 23 24	GMG2 GMG1 GAD FR STEP RST MD2 MD1 OE GST2 GST1	
9	ST	
25 26, 27 28, 29 30, 31 32, 33 34, 35 36, 37 38, 39 40, 41 42	PGND2 OUT2B VM2 RF2 OUT2A OUT1B RF1 VM1 OUT1A PGND1	

Continued on next page.

LV8702V

Continued from preceding page.

Pin No.	Pin name	Equivalent Circuit
2 3 43 44	CP2 CP1 VG VM	
21	VREF	
14	VREG5	
15 16 17 19	DST2 DST1 MONI SST	

Continued on next page.

LV8702V

Continued from preceding page.

Pin No.	Pin name	Equivalent Circuit
20	CHOP	
1	SWOUT	
11	ADIN	
22	SGND	

Operation description



1. Chip enable function

The mode of the IC is switched with ST pin between standby and operation mode. In standby mode, the IC is set to power saving mode and all the logics are reset. During standby mode, the operation of the internal regulator circuit and the charge pump circuit are stopped.

ST	Status	Internal regulator	Charge pump
L or Open	Standby mode	Standby	Standby
H	Operating mode	Operation	Operation

2. STEP pin function

The excitation step progresses by inputting the step signal to the STP pin.

Input		Operation mode
ST	STEP	
L or OPEN	X*	Standby mode
H		Excitation step forward
H		Excitation step keep

* Don't care

3. Input timing

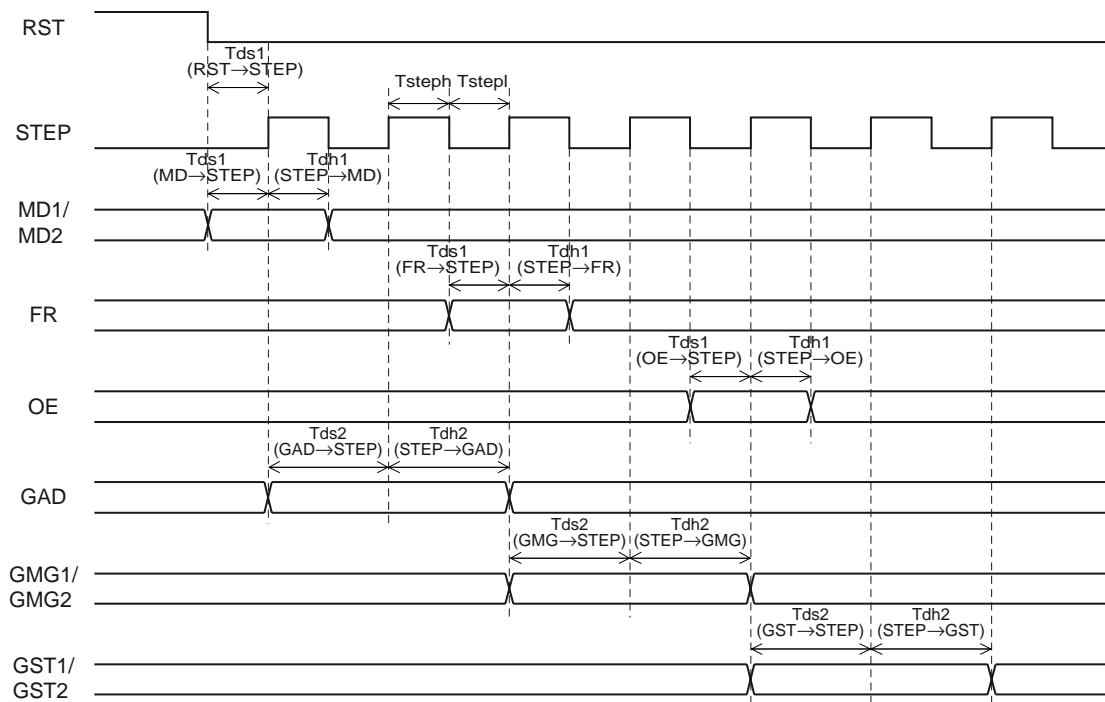

TstepH/TstepL : Clock H/L pulse width (min 12.5μs)

Tds1 : Data set-up time (min 12.5μs)

Tdh1 : Data hold time (min 12.5μs)

Tds2 : Data set-up time (min 25μs)

Tdh2 : Data hold time (min 25μs)

4. Position detection monitor function

The MONI position detection monitoring pin is of an open drain type.
 When the excitation position is in the initial position, the MONI output is placed in the ON state.
 (Refer to "Examples of current waveforms in each of the excitation modes.")

5. Setting constant-current control reference current

This IC is designed to automatically exercise PWM constant-current chopping control for the motor current by setting the output current. Based on the voltage input to the VREF pin and the resistance connected between RF and GND, the output current that is subject to the constant-current control is set using the calculation formula below:

$$I_{OUT} = (V_{REF}/5)/R_F \text{ resistance}$$

The above setting is the output current at 100% of each excitation mode.

For example, where VREF=1.5V and RF resistance 0.2Ω, we obtain output current as follows.

$$I_{OUT} = 1.5V/5/0.2\Omega = 1.5A$$

When high-efficient drive function is on, I_{OUT} is adjusted automatically within the range of the current value set by VREF.

6. Reset function

RST	Operation mode
L or OPEN	Normal operation
H	RESET status

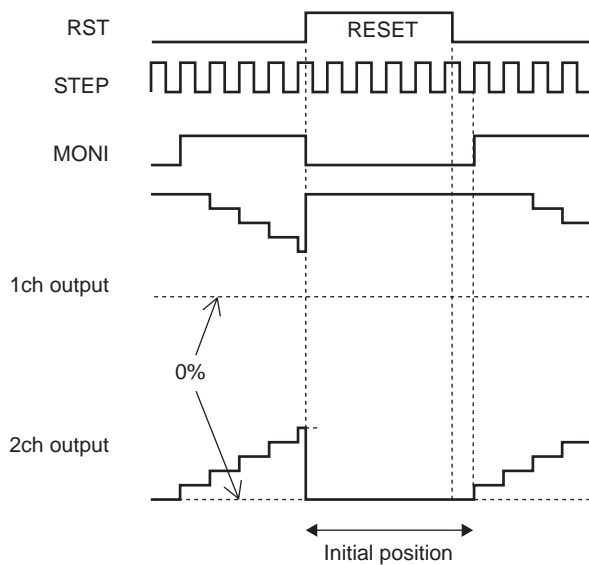

When RST pin = "H", the excitation position of the output is set to the initial position forcibly and MONI output is turned on. And then by setting RST = "L", the excitation position moves forward with the next step signal.

7. Output enable function

OE	Operation mode
H	Output OFF
L or OPEN	Output ON

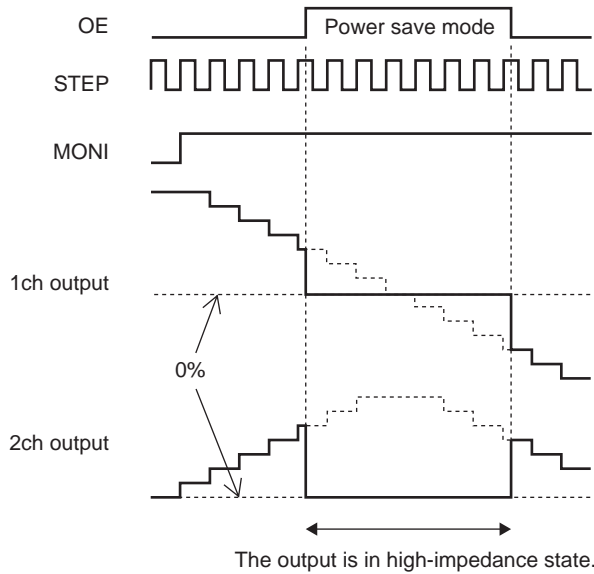

When OE pin = “H”, the output is turned off forcibly and becomes a high-impedance output.

However, since the internal logic circuit is in operation, an excitation position moves forward if step signal is input to STEP pin. Therefore, by setting back to OE = “L”, the output pin outputs signal based on the excitation position by step signal.

8. Excitation mode setting function

MD1 and MD2 pin set excitation mode of the stepping motor as follows.

MD1	MD2	Excitation mode	Initial position	
			1ch	2ch
L or OPEN	L or OPEN	full step excitation	100%	-100%
H	L or OPEN	half step excitation	100%	0%
L or OPEN	H	quarter step excitation	100%	0%
H	H	half step excitation (full-torque)	100%	0%

The position of excitation mode is set to the initial position when: 1) a power is supplied and 2) counter is reset in each excitation mode.

During full step excitation mode, high-efficient drive function is turned off even when GAD = “H”.

9. Forward/reverse switching function

FR	Operation mode
L or OPEN	CW
H	CCW

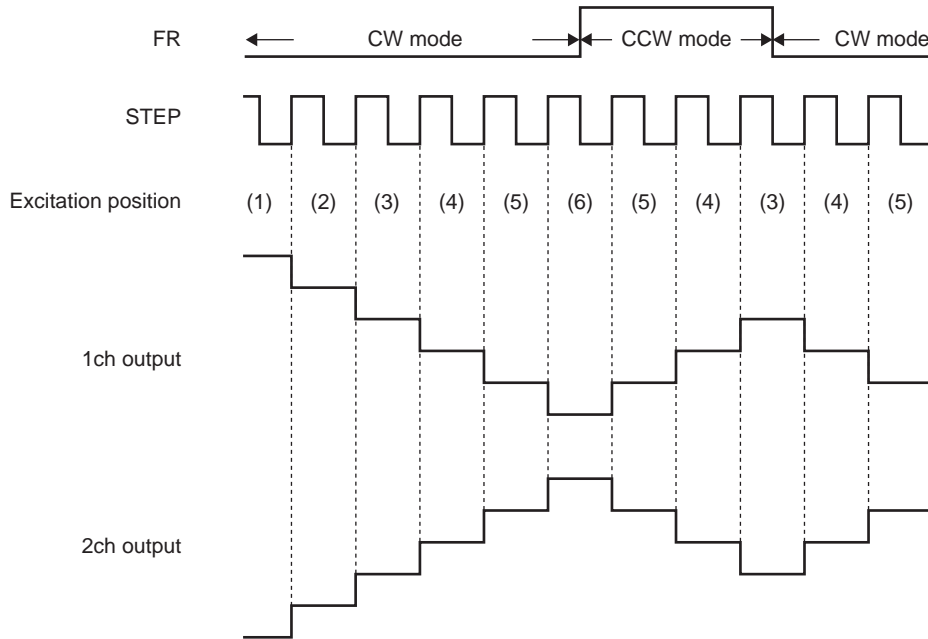

The built-in DA converter moves forward by 1bit with the rise of step signal that is input to STEP pin.

Also a mode is switched between CW and CCW by setting FR pin.

In CW mode, the phase of 2ch current delays by 90° compared to that of 1ch current.

In CCW mode the phase of 2ch current moves forward by 90° compared to 1ch current.

10. Chopping frequency setting

When you control constant current of this IC, chopping is performed using the frequency defined in the capacitor (Cchop) connected between CHOP pin and GND.

The calculation for the value of chopping frequency is:

$$F_{chop} = I_{chop} / (C_{chop} \times V_{tchop} \times 2) \text{ (Hz)}$$

I_{chop} : Capacitor charge and discharge current typ: 10μA

V_{tchop} : Charge and discharge hysteresis voltage ($V_{tup} - V_{tdown}$) typ: 0.5V

For example, where $C_{chop} = 200\text{pF}$, we obtain F_{chop} as follows:

$$F_{chop} = 10\mu\text{A} / (200\text{pF} \times 0.5\text{V} \times 2) = 50\text{kHz}$$

11. Blanking time

If you attempt to control PWM constant current chopping of the motor current, when the mode shifts from DECAY to CHARGE, noise is generated in sense resistor pin due to the recovery current of parasitic diode flowing into current sense resistor, and this may cause error detection. The blanking time avoids noise at mode switch. During the blanking time, even if noise is generated in sense resistor, a mode does not switch from CHARGE to DECAY. In this IC, the blanking time is fixed to approximately 1μs.

LV8702V

12. Output current vector locus (1step is normalized to 90°)

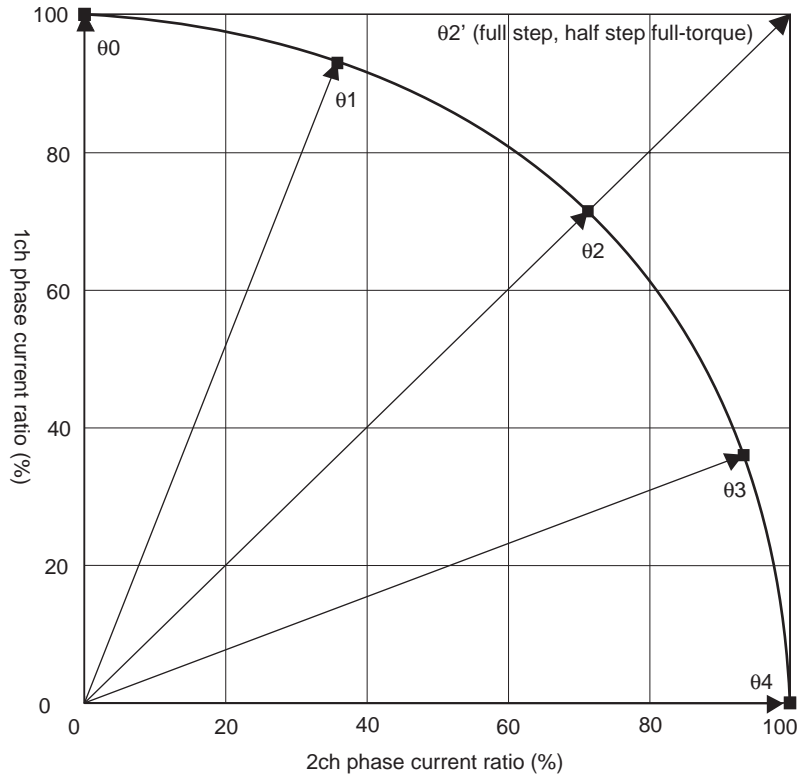

Setting current ration in each excitation mode

STEP	quarter step (%)		half step (%)		half step full-torque (%)		full step (%)	
	1ch	2ch	1ch	2ch	1ch	2ch	1ch	2ch
θ0	100	0	100	0	100	0		
θ1	92	38						
θ2	70	70	70	70	100	100	100	100
θ3	38	92						
θ4	0	100	0	100	0	100		

LV8702V

13. The example of current waveform in each excitation mode
full step excitation (CW mode)

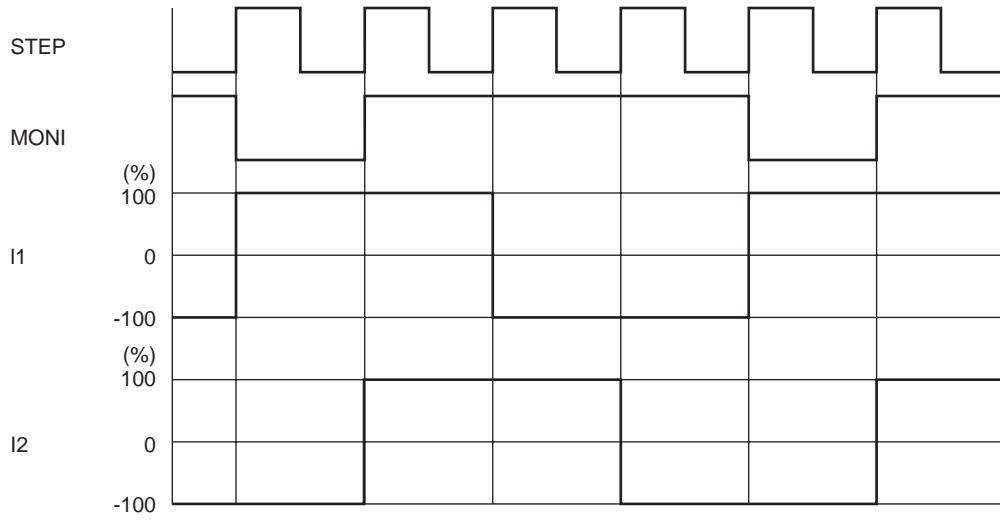

half step excitation full-torque (CW mode)

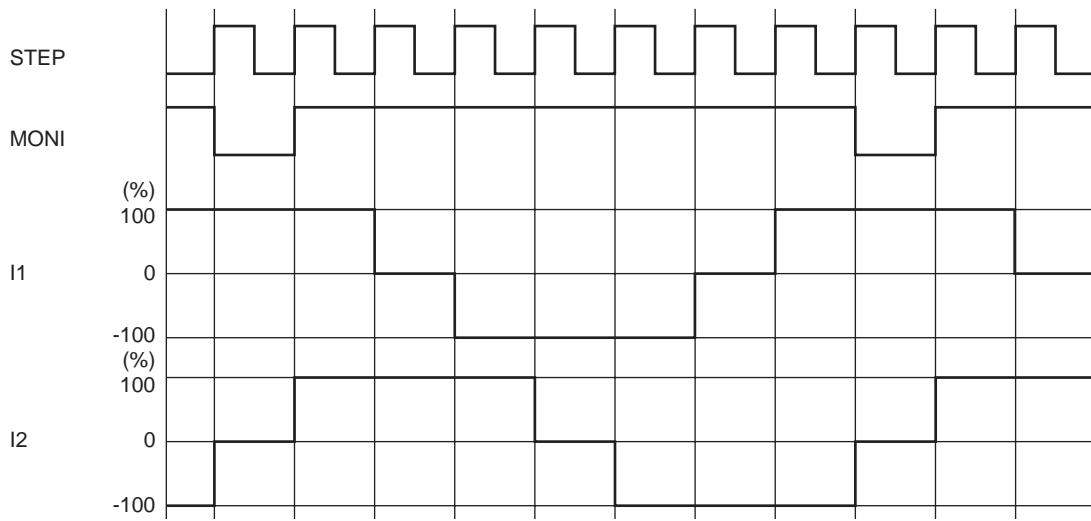

LV8702V

half step excitation (CW mode)

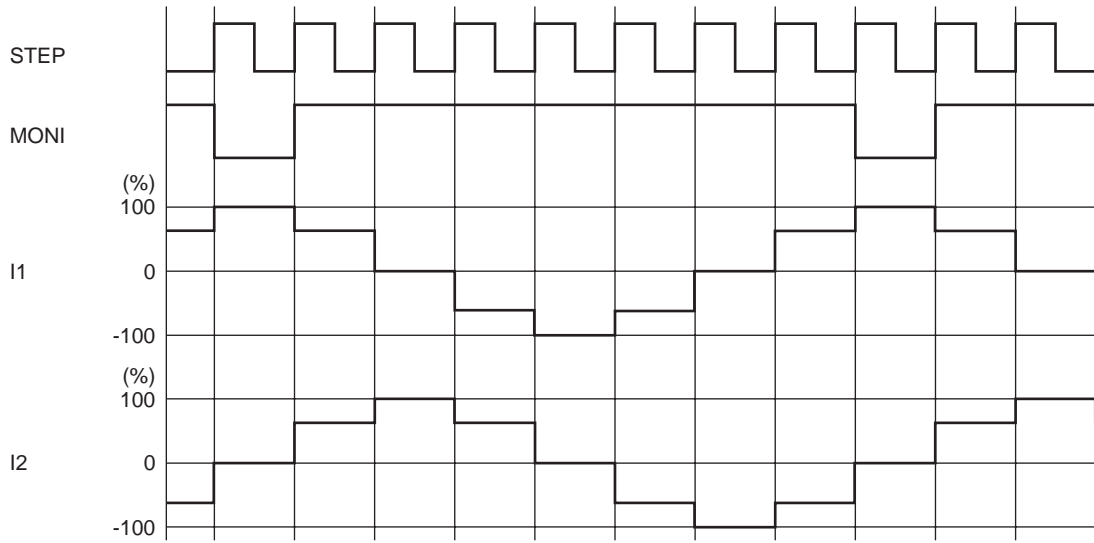

quarter step excitation (CW mode)

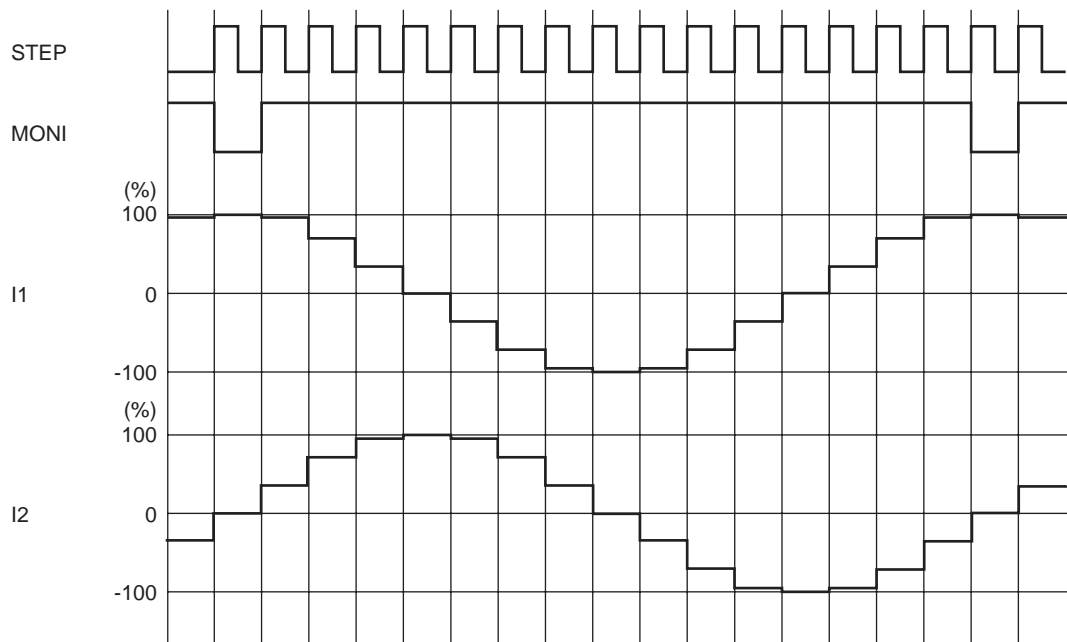

14. Current control operation specification

(Sine wave increase)

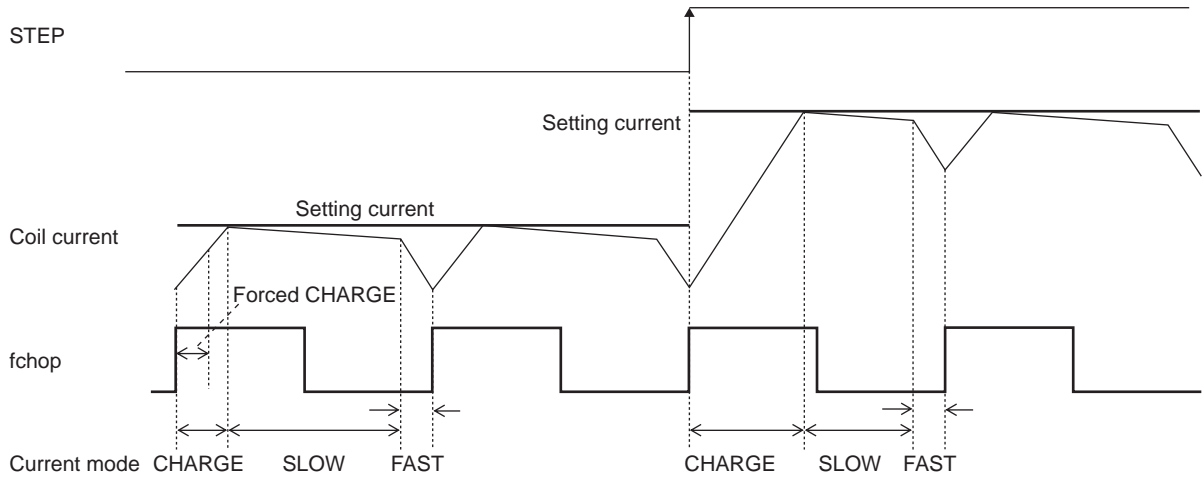

(Sine wave decrease)

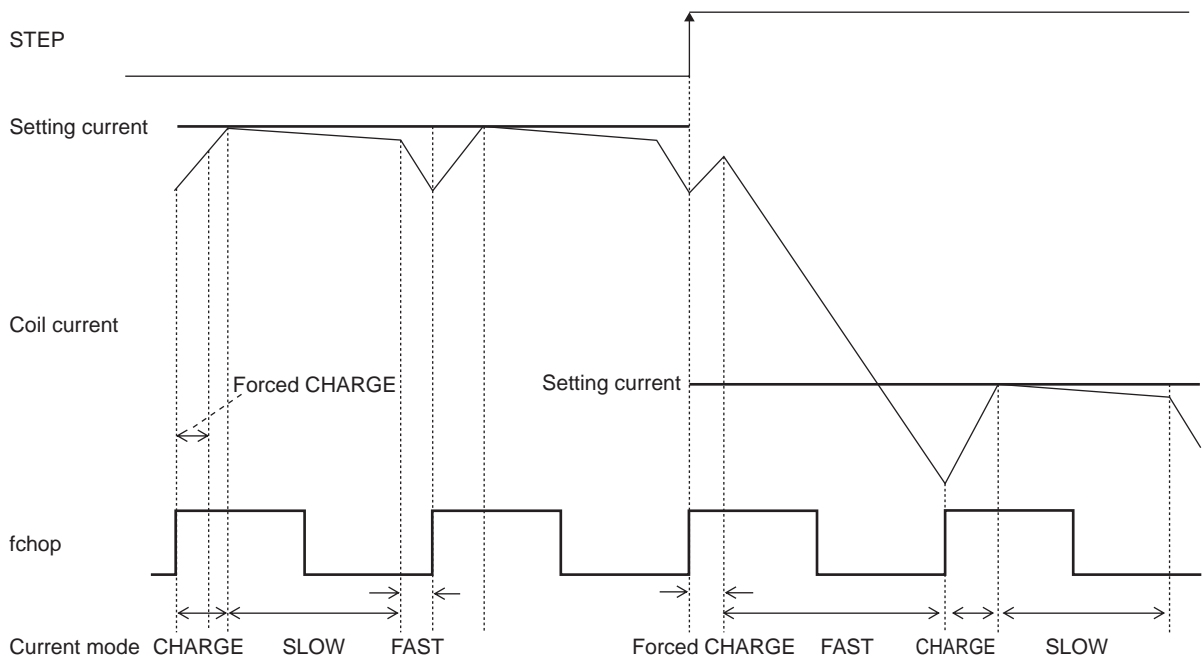

Each current mode is operated according to the following sequence.

- At rise of chopping frequency, the CHARGE mode begins. (In the time defined as the “blanking time,” the CHARGE mode is forced regardless of the magnitude of the coil current (ICOIL) and set current (IREF).)
- The coil current (ICOIL) and set current (IREF) are compared in this blanking time.
 - When $(ICOIL < IREF)$ state exists ;
 - The CHARGE mode up to $ICOIL \geq IREF$, then followed by changeover to the SLOW DECAY mode, and finally by the FAST DECAY mode for approximately $1\mu s$.
 - When $(ICOIL < IREF)$ state does not exist ;
 - The FAST DECAY mode begins. The coil current is attenuated in the FAST DECAY mode till one cycle of chopping is over.

Above operations are repeated. Normally, the SLOW (+FAST) DECAY mode continues in the Triangle wave increasing direction, then entering the FAST DECAY mode till the current is attenuated to the set level and followed by the SLOW DECAY mode.

15. High-efficient drive function

This IC includes high-efficient drive function. When high-efficient drive function is turned on, I_{OUT} is adjusted automatically within the current value set with VREF pin. When high-efficient drive function is turned off, the current value of I_{OUT} becomes the maximum value set by REF pin.

1) High-efficient drive enable function

High-efficient drive function is switched on and off with GAD pin.

However, in the case of full step excitation mode (MD1 = MD2 = "L"), even when GAD = "H", high-efficient drive function is turned off.

Even if you adjust the GMG1, GMG2 of 15-2) and GST1, GST2 of 15-3), in the case of abrupt motor acceleration or load variation to the extent that auto adjuster cannot follow up and eventually leads to the rotation stepping-out, it is recommended that you turn off the high-efficient drive function temporally. As high-efficient control may become unstable due to the control signal from the motor is unstable during low speed rotation, it is also recommended to turn off this function as well.

GAD	Operation mode
L or OPEN	Normal mode
H	High-efficient mode (except for full step excitation mode)

Recommended speed of high-efficient drive

excitation	Operating conditions	Speed
half step half step full-torque	HB motor/no-load	over 1500pps
	PM motor/no-load	over 1000pps
quarter step	HB motor/no-load	over 3000pps
	PM motor/no-load	over 2500pps

When there is a load, the high-efficient drive is enabled at slower speed.

2) High-efficient drive margin adjuster function

By setting GMG1 and GMG2 pin, margin for step-out is adjusted.

Where GMG1 = GMG2 = "L", I_{OUT} and consumption current are at the lowest. In some case, as the I_{OUT} becomes lower, the number of boost-up process* may increase triggered by slight change of load. With insufficient driving capability, you need to increase the margin setting. One way to set GMG1 and GMG2 is to minimize boost-up level, then lower the margin from high to low to optimize the margin where motor rotates stably.

In the application where load variation is excessive, you need to have a larger margin.

GMG1	GMG2	Setting	Current consumption	Load following capability
L or OPEN	L or OPEN	Margin: small	Smallest	Ordinary
H	L or OPEN	Margin: middle	Smaller	Good
L or OPEN	H	Margin: large	Small	Better
H	H	Setting is inhibited	-	-

*: This is a function to increase I_{OUT} rapidly as soon as a possible stepping out is detected due to load variation during high efficiency drive.

3) Boost-up adjuster function

During high-efficient drive, boost-up adjuster function detects a possibility of step-out caused by such factors as abrupt load variation and then boosts up I_{OUT} at once (Boost-up process). You can set a level of boost-up by setting GST1 and GST2 pins. One way to set GST1 and GST2 is to increase boost-up level from minimum to maximum within the maximum load condition and select the optimum boost-up setting where motor rotates without stepping out. Also, boost-up level varies depends on reference current defined by VREF. Therefore, you can increase load following capability by increasing VREF voltage.

The higher the boost-up level is, the more the IC becomes tolerant for abrupt load variation. However, rotation stability may become poor (vibration and rotation fluctuation may occur) because excessively high boost-up level leads to rapid increase of I_{OUT} at load variation. You may be able to improve poor rotation stability with high boost-up level by increasing high-efficient drive margin.

GST1	GST2	Setting	Increase of Iout	load following capability	Rotation stability
L or OPEN	L or OPEN	Boost-up level minimum	$\{(VREF/5)/RF \text{ resistance}\} \times 1/128$	Ordinary	Best
H	L or OPEN	Boost-up level low	$\{(VREF/5)/RF \text{ resistance}\} \times 4/128$	Good	Better
L or OPEN	H	Boost-up level high	$\{(VREF/5)/RF \text{ resistance}\} \times 16/128$	Better	Good
H	H	Boost-up level maximum	$\{(VREF/5)/RF \text{ resistance}\} \times 64/128$	Best	Ordinary

4) External component

The resistance value of Ra1, Ra2 (control signal resistors) is adjusted in such a way as to set the maximum SWOUT output voltage during motor rotation to 12V in ADIN pin. Preferably, resistance values of Ra1 and Ra2 are as high as possible to the extent that does not influence waveform. (Recommendation for Ra1: 15kΩ, Ra2: 100kΩ).

In some motor where boost-up process occurs at a high speed rotation of 7000pps to 8000pps or higher (HB motor: Half step excitation), you can suppress boost-up by lowering Ra1. Moreover, you can achieve high efficiency at lower speed of 1500pps or lower by increasing resistance for Ra1 (HB motor: Half step excitation). Although it depends on a usage motor, step-out is detectable at higher speed rotation by attaching smaller resistor for Ra1.

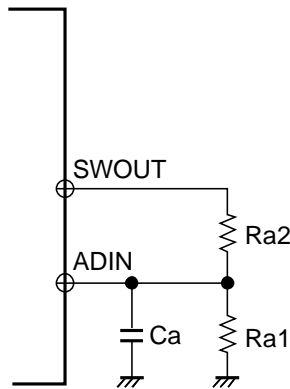

5) Drive status warning function

DST1 and DST2 are open-drain output. The driving status can be monitored through a status of DST1 and DST2 pins. When step-out status is detected, DST1 is on for a period of 1 step. Likewise, when small step-out margin status is detected, DST2 turns on for the period of 1 step. In the case of output short status or overheat status, DST1 and DST2 stay on until ST = "L".

Step-out status and small step-out margin status are detectable during high-efficient drive only. In some cases, step-out status may not be detected properly. Hence, make sure to verify the operation with the usage application. If step-out or small step-out margin status occur frequently, make sure to set a large high-efficient drive margin or higher boost-up level.

DST1	DST2	Status
OFF	OFF	Normal status
ON	OFF	Step-out status *1 (this function is enabled only in high-efficient drive)
OFF	ON	Small step-out margin status *2 (this function is enabled only in high-efficient drive)
ON	ON	Output short status or overheat status

*1: Although it depends on a usage motor, step-out is detectable at higher speed rotation by attaching smaller resistor for Ra1.

*2: If DST2 alone is turned on, boost-up processing is performed.

16. Output short protection circuit

Output short protection circuit is included in this IC which sets an output to standby mode and turns on warning output. This protection circuit prevents IC destruction when the output is short due to power short or ground short.

1) Operation overview

When output short is detected, short detection circuit operates. If the short status continues for the period of internal timer ($\approx 2\mu\text{s}$), the output of 1ch/ 2ch is turned off. If the short status exceeds the timer latch time ($\approx 32\mu\text{s}$) set in the internal timer, the output is turned on again and detects short status again. If short is detected again, all the output of 1ch/ 2ch are switched to standby mode and the status is kept. To cancel the standby status, set ST = "L".

2) Error status warning output pin (DST2, DST1)

When the IC detects error status and protection circuit operates, DST2 pin and DST1 pin outputs the error status to CPU side.

This pin is open-drain output. When error status is detected, DST2 and DST1 output turn on (DST2 = DST1 = "L").

DST2/DST1 pins are turned on in the following statuses:

Error status	DST2	DST1
Short is detected in 1ch side.	ON	ON
Short is detected in 2ch side.	ON	ON
When overheat is detected.	ON	ON

17. Charge pump circuit

When ST pin is set to "H", charge pump circuit operates and VG pin voltage increases from VM voltage to VM + VREG5 voltage. Because the output is not turned on if VM+4V or more is not pressured, the voltage of the VG pin recommends the drive of the motor to put the time of tONG or more, and to begin.

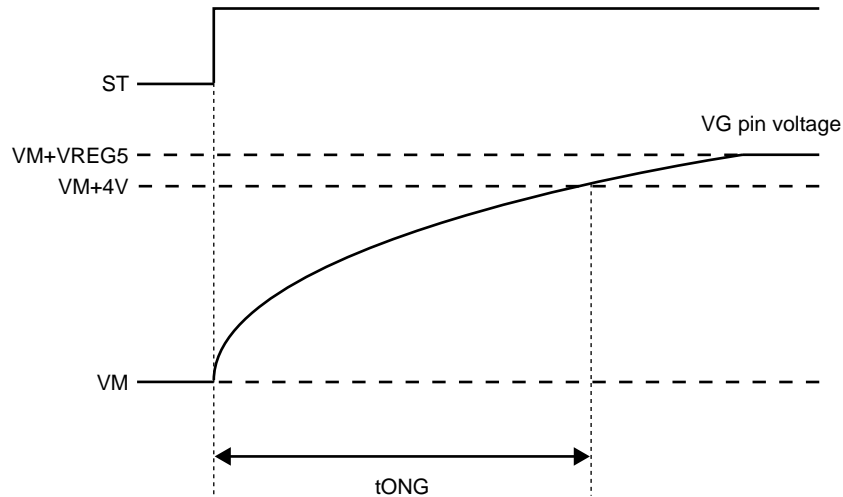

Fg. VG pin voltage

18. Current save function when motor is stopped

SST pin is the open-drain output. When STEP signal is not input for about 16mS, (min: 13mS, max: 23mS), SST pin detects that the rotation of the motor is stopped and SST pin is turned on. At this time, high-efficient drive function is turned off automatically and full current value is set for I_{OUT} by VREF pin. And then after signal is input to STEP pin, SST pin is turned off and high-efficient control function is enabled.

In this driver, the circuit constituent is as follows. By decreasing VREF voltage when the motor is stopped, I_{OUT} current can be saved. However, this function is unusable when you rotate motor at which input cycle of STEP pulse signal is 16mS or longer.

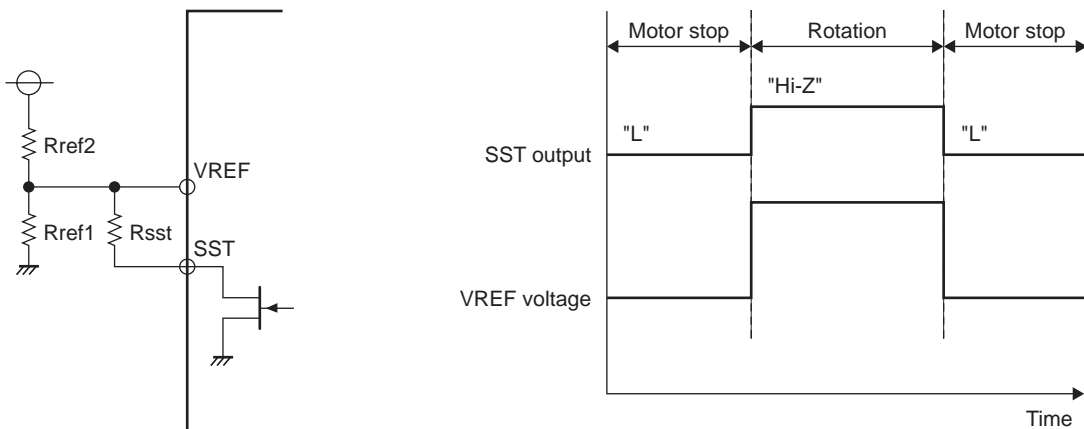

1) With STEP signal where Rref1 = 30kΩ, Rref2 = 68kΩ and Rsst = 5kΩ
 $VREF1 = 5V \times 30k\Omega / (68k + 30k\Omega) \approx 1.53V$
 Where VREF1 = 1.53V,
 $I_{OUT} = VREF / 5 / 0.22\Omega \approx 1.39A$

2) Without STEP signal where Rref1 = 30kΩ, Rref2 = 68kΩ, and Rsst = 5kΩ
 $VREF2 = 5V \times 4.3k\Omega / (68k + 4.3k\Omega) \approx 0.3V$
 Where VREF2 = 0.3V
 $I_{OUT} = VREF / 5 / 0.22\Omega \approx 0.27A$

LV8702V

Example of application circuit

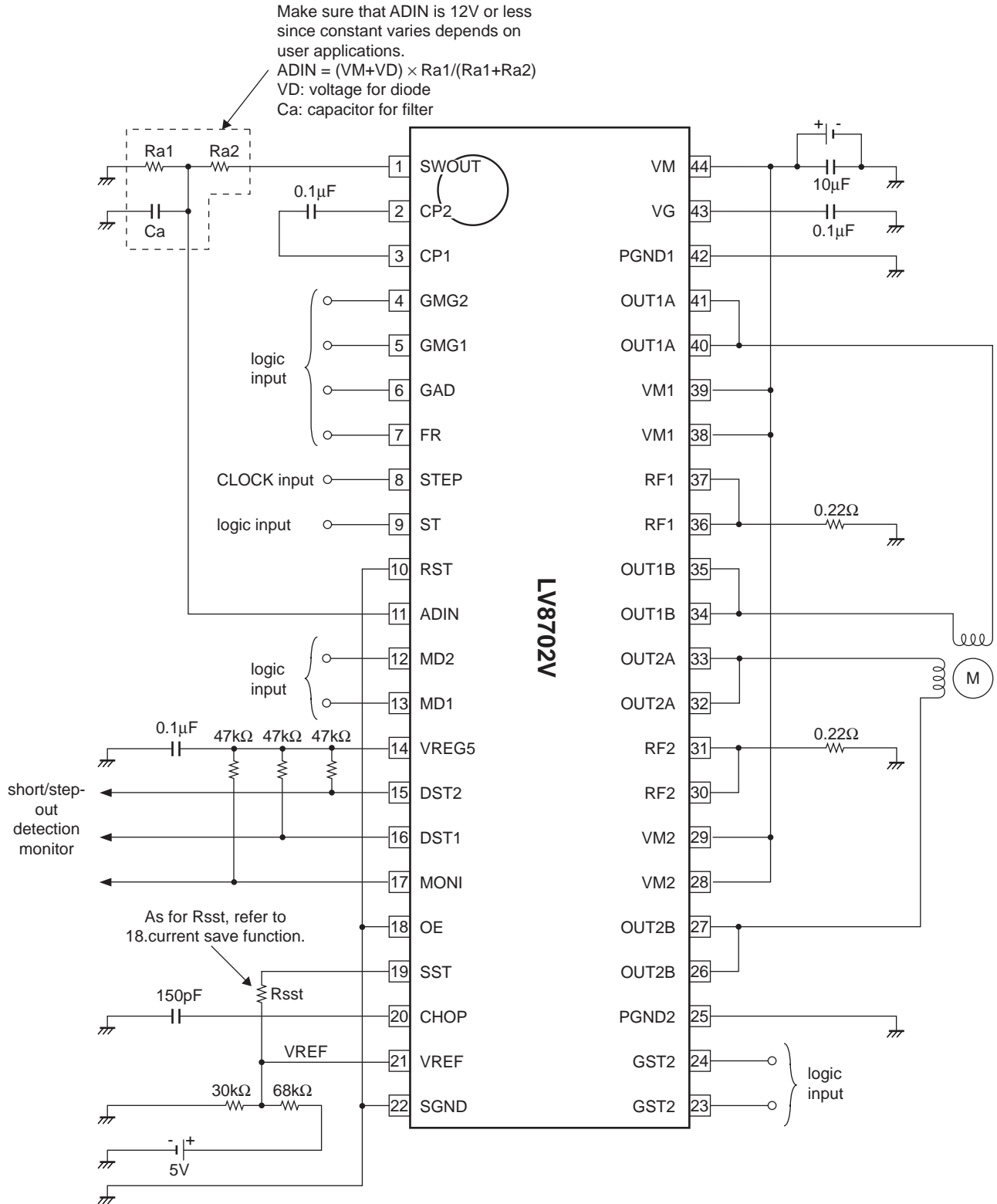

Calculation for each constant setting according to the above circuit diagram is as follows.

1) Constant current (100%) setting

$$VREF = 5V \times 30k\Omega / (68k\Omega + 30k\Omega) \approx 1.53V$$

When $VREF = 1.53V$:

$$I_{OUT} = VREF / 0.22\Omega \approx 1.39A$$

2) Chopping frequency setting

$$F_{chop} = I_{chop} / (C_{chop} \times V_{tchop} \times 2)$$

$$= 10\mu A / (150pF \times 0.5V \times 2)$$

$$\approx 66.7kHz$$

- SANYO Semiconductor Co.,Ltd. assumes no responsibility for equipment failures that result from using products at values that exceed, even momentarily, rated values (such as maximum ratings, operating condition ranges, or other parameters) listed in products specifications of any and all SANYO Semiconductor Co.,Ltd. products described or contained herein.
- Regarding monolithic semiconductors, if you should intend to use this IC continuously under high temperature, high current, high voltage, or drastic temperature change, even if it is used within the range of absolute maximum ratings or operating conditions, there is a possibility of decrease reliability. Please contact us for a confirmation.
- SANYO Semiconductor Co.,Ltd. strives to supply high-quality high-reliability products, however, any and all semiconductor products fail or malfunction with some probability. It is possible that these probabilistic failures or malfunction could give rise to accidents or events that could endanger human lives, trouble that could give rise to smoke or fire, or accidents that could cause damage to other property. When designing equipment, adopt safety measures so that these kinds of accidents or events cannot occur. Such measures include but are not limited to protective circuits and error prevention circuits for safe design, redundant design, and structural design.
- In the event that any or all SANYO Semiconductor Co.,Ltd. products described or contained herein are controlled under any of applicable local export control laws and regulations, such products may require the export license from the authorities concerned in accordance with the above law.
- No part of this publication may be reproduced or transmitted in any form or by any means, electronic or mechanical, including photocopying and recording, or any information storage or retrieval system, or otherwise, without the prior written consent of SANYO Semiconductor Co.,Ltd.
- Any and all information described or contained herein are subject to change without notice due to product/technology improvement, etc. When designing equipment, refer to the "Delivery Specification" for the SANYO Semiconductor Co.,Ltd. product that you intend to use.
- Upon using the technical information or products described herein, neither warranty nor license shall be granted with regard to intellectual property rights or any other rights of SANYO Semiconductor Co.,Ltd. or any third party. SANYO Semiconductor Co.,Ltd. shall not be liable for any claim or suits with regard to a third party's intellectual property rights which has resulted from the use of the technical information and products mentioned above.

This catalog provides information as of October, 2012. Specifications and information herein are subject to change without notice.