

TITLE

PULSE TRANSFORMER



1000 PARKERS LAKE ROAD
WAYZATA, MN 55391
(952) 475-1173

PART NUMBER **22100**

REV K PAGE 1 END

SPECIFICATIONS

- 1. INDUCTANCE: (1 - 3) @ 10Khz, 0.1 V > 2 Mhy
- 2. LEAKAGE INDUCTANCE: (1 - 3) @ 100Khz, (4 - 6) shorted < 25 uhy
- 3. INTERWINDING CAPACITANCE: (1 - 3) to (4 - 6) @ 100 Khz < 7 pf
- 4. TURNS RATIO: (1 - 2) : (2 - 3) : (4 - 5) : (5 - 6) = 1:1:1:1
- 5. DC RESISTANCE: (1 - 3), (4 - 6) = 0.6 ohm nominal
- 6. DIELECTRIC STRENGTH: (1 - 3) to (4 - 6) = 3750 VAC APPLIED AT RATE OF
500 VOLTS A SECOND OR 5250 VDC

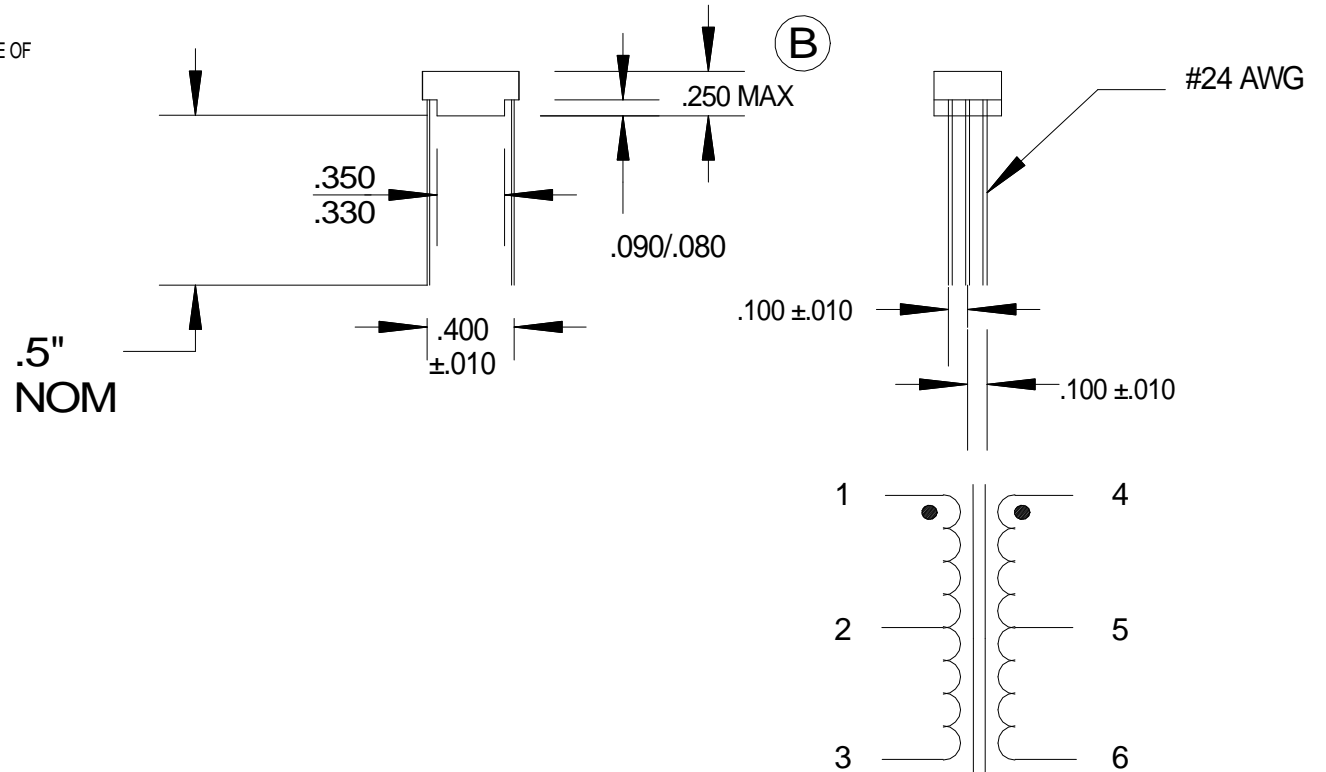
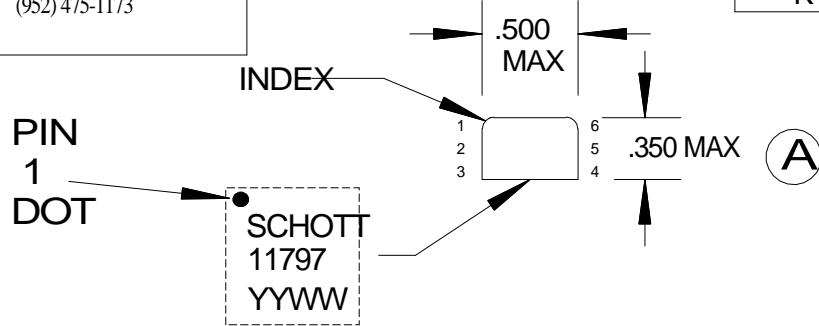

TOLERANCES	2 PLACE	3 PLACE	ANGLE
UNLESS OTHERWISE NOTED	.01	+ .005	+ 5°