

Bourns® Model EMS22 Non-Contacting Magnetic Encoder

Sensors & Controls Product Brochure

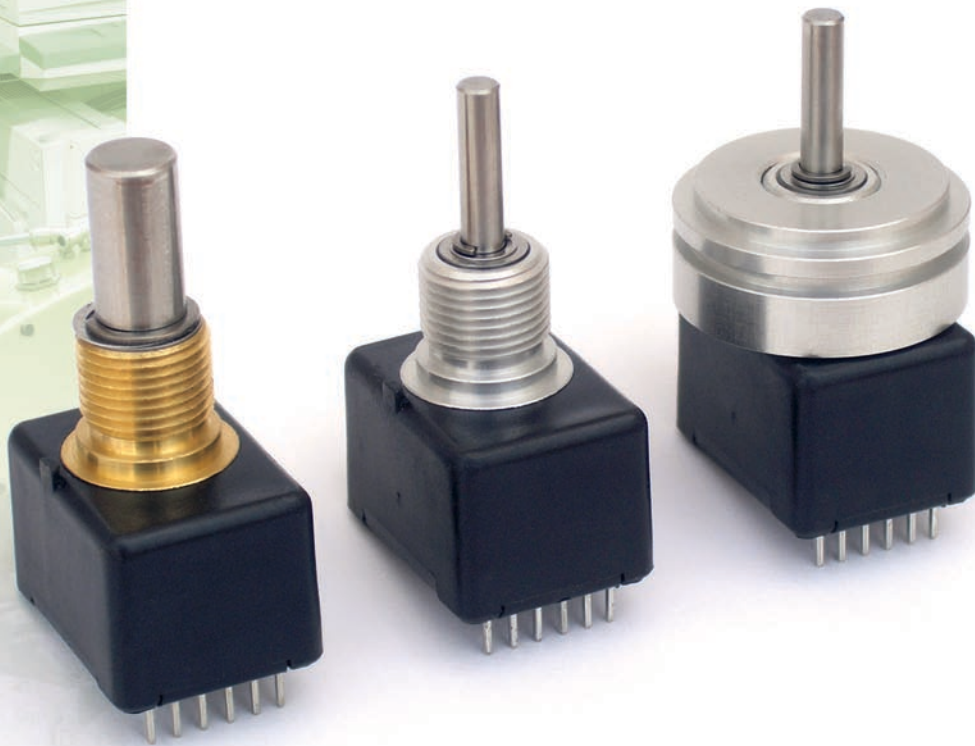

Bourns® Model EMS22 Product Description

Bourns® Model EMS22 is a non-contacting rotary magnetic encoder with a Hall Effect application-specific standard product (ASSP) capable of producing four distinct output waveforms. These waveforms include 2-bit quadrature up to 256 PPR*, Step/Direction up to 512 PPR, Pulse-Width Modulated (PWM) output with 1024 positions, and Absolute with 1024 positions.

Model EMS22 is available in both a 3.3 and 5.0 Vdc supply voltage and is offered in two different versions. This product has the capability of rotating up to 10,000 RPM while maintaining code accuracy, making it suitable for MMI applications such as industrial automation. This performance is achieved by utilizing dual ball bearings in the construction of the device, resulting in extended rotational life up to 100,000,000 shaft revolutions (beyond 100,000,000 shaft revolutions in some configurations).

* Pulses per Revolution

** Ingression Protection

The EMS22 non-contacting encoder is ideal for use in harsh environments where extreme levels of temperature, moisture and particles are present. The outstanding performance of this device is attributed to the non-contacting technology and superior performance of the austriamicrosystems® AS5040 Hall Effect ASSP. In addition, this product is sealed to IP** 65 with an optional upgrade to IP 67.

The EMS22 is RoHS compliant in accordance with Directive 2002/95/EC of the European Parliament and Council of 27 Jan 2003 on the restriction of the use of certain hazardous substances in electrical and electronic equipment.

This model is produced and assembled utilizing state-of-the-art production equipment along with lean principles to provide our customers with a high performance product at a competitive price.

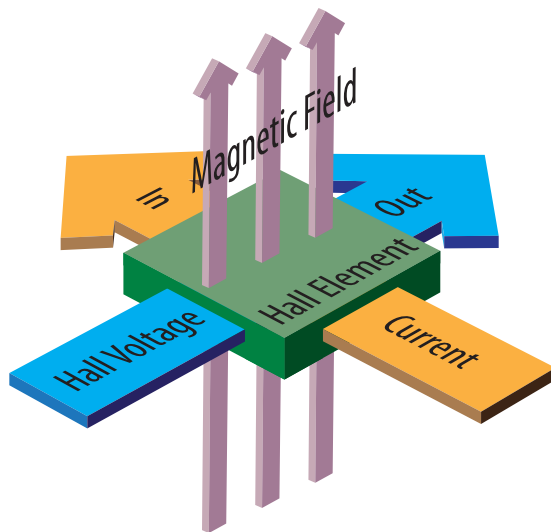

Figure 1: Hall Effect Concept

What is Hall Effect?

Discovered by Edwin Hall in 1879, Hall Effect refers to the potential difference on opposite sides of a bar-shaped conducting or semi-conducting material (Hall element). This potential difference (voltage) is produced by a magnetic field applied perpendicular to the Hall element through which an electric current flows. Figure 1 is provided to clarify this concept by illustration. Figure 2 demonstrates two different states of the AS5040 ASSP as the magnet rotates in close proximity to the ASSP.

EMS22 Output Waveforms

Quadrature: This output waveform is the most common among all contacting and non-contacting encoders. Quadrature, also known as 2-bit quadrature or incremental, is often used to determine magnitude (count) and direction (up/down) by an external interface circuit. EMS22 comes equipped with such capability; an external interface circuit is not required. It also offers an indexed output with an adjustable width of one or three times the absolute position value that can be used for counting the shaft rotation.

Direction/Step: This output is very similar to the quadrature waveform but offers up to 512 PPR, as opposed to 256 PPR in quadrature. This output can be used in incremental counting applications where a better resolution is desired. Indexing output is also available with a Direction/Step output waveform.

Absolute: Absolute output refers to the absolute angular position. This type of output is especially useful for applications where the absolute position of a device, such as a camera, is necessary to locate an object. Also with 1024 distinct angular positions, the EMS22 offers very high resolution indexing at every 0.35° . This type of output code is not affected by a power outage to the encoder since each angular position of the encoder has a unique code.

PWM: Pulse-Width Modulation is another form of absolute waveform that utilizes the square wave output generated by the sensor to control the duty cycle of the output at different desired shaft positions. The EMS22 encoder can generate pulse widths as low as $1\ \mu\text{s}$, and as high as $1024\ \mu\text{s}$ in a complete signal period of $1025\ \mu\text{s}$. Some advantages of using this output waveform over other output types include immunity to noise and faster data acquisition.

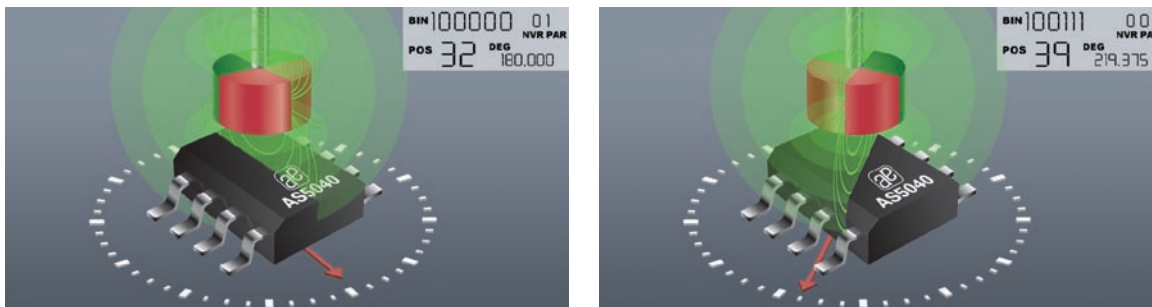

Figure 2: AS5040 ASSP in Two Different States

How the EMS22 Rotary Magnetic Encoder Works

The EMS22 produces a sinusoidal signal by rotation of the magnet in close proximity to the ASSP, based on the Hall Effect phenomenon. The sinusoidal signal is then converted to the desired output waveform by the ASSP that is preprogrammed at the factory to produce one of the output signals below:

- *Quadrature*
- *Direction/Step*
- *PWM*
- *Absolute*

Figure 3 below shows the steps involved in generating an output signal.

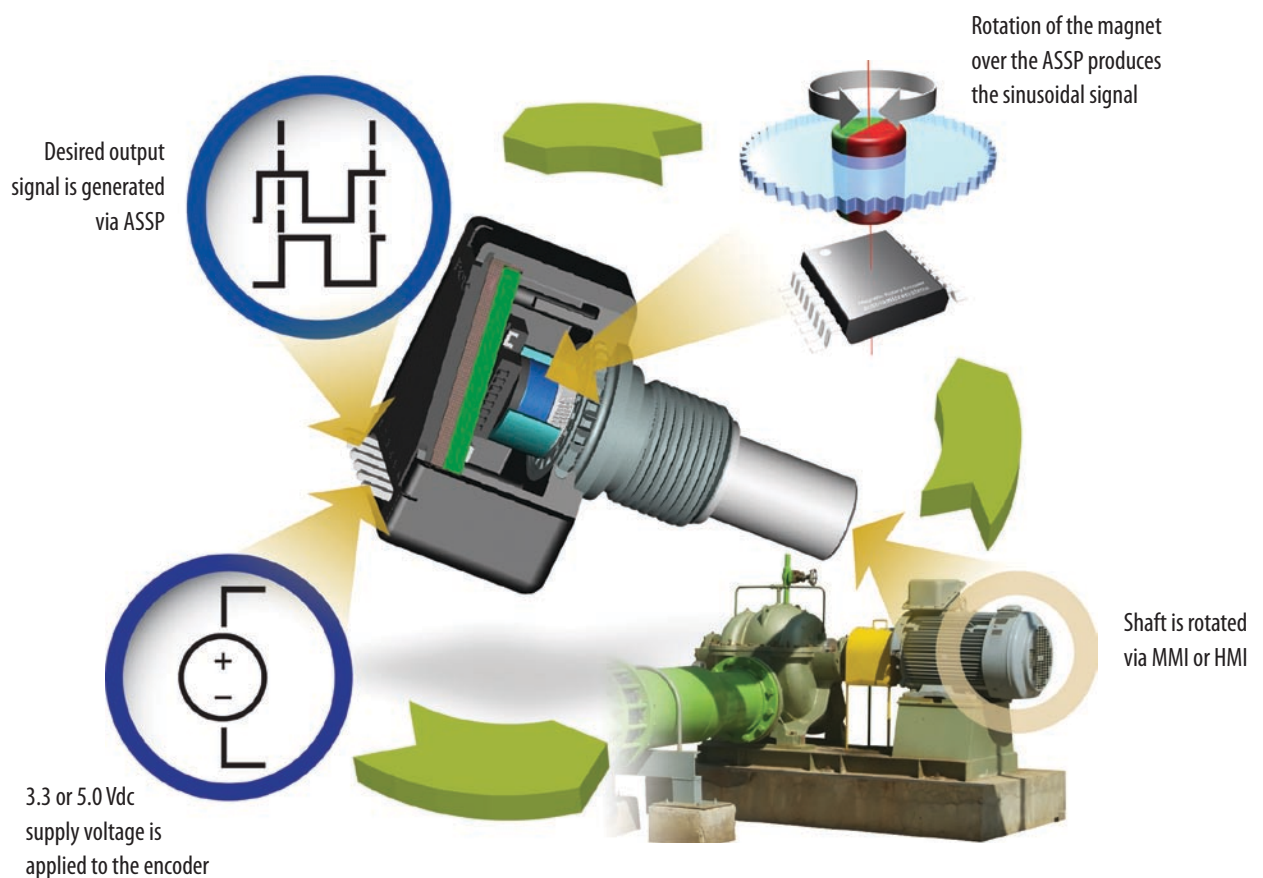

Figure 3: Output Signal Generation Steps in EMS22

Why Use an EMS22 Magnetic Encoder?

The EMS22 can offer enhanced reliability in harsh environmental conditions such as mud, dust, grease, oil, water and dirt, giving this product an edge in performance over traditional optical and contacting encoders. Figure 4 illustrates examples of harsh environments.

In addition, there are no contacting parts between the magnet and the ASSP to degrade the life expectancy of this type of encoder. As a result,

the EMS22 can have more than 50 times the life expectancy of traditional contacting encoders.

The designer and end user can expect cycle life performance without degradation of signal accuracy, a clear advantage over encoders that use optical or contacting technology.



Figure 4: Examples of Harsh Environments

EMS22 Features and Benefits

Design engineers with constraints such as cost, space, circuit complexity and resolution will appreciate the unique features and benefits of the Model EMS22.

EMS22 non-contacting rotary magnetic encoders can be interconnected in a **daisy-chain configuration** for a serial read-out option. This option is beneficial where memory overhead and space for wiring each individual encoder separately is critical in the construction of a control device as illustrated in Figure 5. The output of this configuration is the combined output of each individual encoder connected in series to the microprocessor.

Another great capability of this product is the **chip-select** option. This option allows the interrogation of each encoder individually by the microprocessor. Unlike daisy-chain, this feature takes less time to execute, ultimately enhancing the speed of the control loop response.

If temperature variation is a critical factor in the application, the EMS22 offers excellent performance in a **wide temperature range**, from - 40 °C to + 125 °C (- 40 °F to + 257 °F). This feature is suitable for applications in extremely cold and hot temperature conditions that can affect the output performance of optical and contacting encoders.

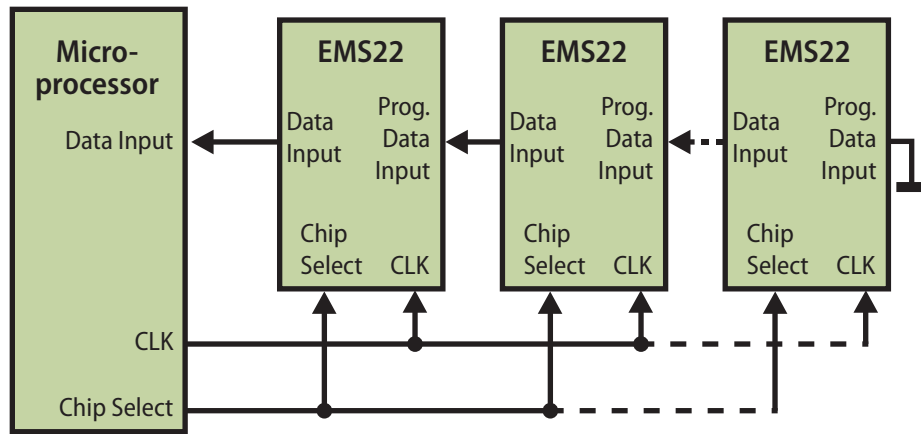

Figure 5: Daisy-Chain Hardware Configuration

Designers can choose from a **variety of output signals** to fit their application needs, whether it is a simple counter, or precision sensing. The EMS22 is capable of operating with either a +5.0 Vdc supply voltage, or the more energy efficient +3.3 Vdc supply voltage.

Table 1 below provides a comparison of the various technologies, output types, supply voltages, and resolution that can be achieved with each Bourns® Encoder model family.

Bourns® Encoder Model	Technology	Output Type(s)	Supply Voltage (Vdc)	Resolution (PPR)/ States*
EAW (ACE)	Contacting	Absolute	3.3 & 5.0	128*
ECW	Contacting	Quadrature	3.3 & 5.0	6, 9, 12, 24, 36
EM14	Optical	Quadrature	5.0	8, 16, 32, 64
EN	Optical	Quadrature	5.0	25, 50, 64, 100, 125, 128, 200, 256
EMS22	Magnetic	Quadrature	3.3 & 5.0	32, 64, 128, 256
EMS22	Magnetic	Direction/Step	3.3 & 5.0	64, 128, 256, 512
EMS22	Magnetic	Absolute/PWM	3.3 & 5.0	1024*

Table 1: Comparison of Various Bourns® Models

Applications

Typical applications of the Bourns® EMS22 Rotary Magnetic Encoder with Hall Effect sensors include but are not limited to:

- *Audio mixer and broadcasting equipment*
- *Brushless DC motors*
- *Car audio*
- *Car navigation*
- *Cursor position sensing in oscilloscopes*
- *Food processing and packaging*
- *Forklifts and material handling equipment*
- *Gas pedal position sensing*
- *Headlight position controls*
- *Level setting for ultrasound imaging devices*
- *Light dimmers*
- *Marine applications*
- *Medical devices (non-life critical)*
- *Metal cutting saws*
- *Metal working and instrumentation*
- *Office equipment: printers, scanners, copiers*
- *Power seating position indicators*
- *Power tools*
- *Pressing and punching machines*
- *Replacement of optical encoders*
- *Replacement of potentiometers*
- *Robotics*
- *Servomotor control*
- *Steering wheel position sensing*

Modification Capabilities

The EMS22 Rotary Magnetic Encoder with Hall Effect sensor can be customized to suit your application and design needs. These customizations include but are not limited to:

- *Analog output to 360 degrees*
- *Brushless DC motor commutation*
- *Custom cable and connectors*
- *Custom shaft and bushing configurations*
- *Customized electrical angle from 45 to 360 degrees*
- *High temperature version up to +150 °C*
- *Sealed to IP 67*

Please contact your local Bourns Sales Representative or Field Application Engineer for additional information.





Worldwide Sales Offices

Country	Phone	Fax
Benelux:	+41 (0)41 768 5555	+41 (0)41 768 5510
Brazil:	+55 11 5505 0601	+55 11 5505 4370
China:	+86 21 64821250	+86 21 64821249
France:	+33 (0)2 5473 5151	+33 (0)2 5473 5156
Germany:	+49 (0)69 800 78212	+49 (0)69 800 78299
Ireland/UK:	+44 (0)1276 691087	+44 (0)1276 691088
Italy:	+41 (0)41 768 5555	+41 (0)41 768 5510
Japan:	+81 49 269 3204	+81 49 269 3297
Malaysia (KL Office):	+60 3 71183138	+60 3 71183139
Malaysia (Penang Office):	+60 4 6581771	+60 4 6582771
Singapore:	+65 6348 7227	+65 6348 1272
Switzerland:	+41 (0)41 768 5555	+41 (0)41 768 5510
Taiwan:	+886 2 25624117	+886 2 25624116
UK/Ireland:	+44 (0)1276 691087	+44 (0)1276 691088
USA:	+1-951-781-5500	+1-951-781-5006

Non-Listed European

Countries:	+41 (0)41 768 5555	+41 (0)41 768 5510
-------------------	--------------------	--------------------

Technical Assistance

Region	Phone	Fax
Asia-Pacific:	+886 2 25624117	+886 2 25624116
Europe:	+41 (0)41 768 5555	+41 (0)41 768 5510
Americas:	+1-951-781-5500	+1-951-781-5700

www.bourns.com

Bourns® products are available through an extensive global network of representatives and distributors.

To obtain technical applications assistance, a quotation, or to place an order, contact a Bourns representative in your area.

Specifications subject to change without notice. Actual performance in specific customer applications may differ due to the influence of other variables. Customers should verify actual device performance in their specific applications.



"austriamicrosystems" is a registered trademark of austriamicrosystems AG in the U.S. and other countries.

"Bourns" is a registered trademark of Bourns, Inc. in the U.S. and other countries.

COPYRIGHT © 2008, BOURNS, INC. • LITHO IN U.S.A. • WAG • 02/08 • 2M/SC0676