

**Silicon NPN Power Transistors**

**BD707 BD709 BD711**

**DESCRIPTION**

- With TO-220C package
- The BD707 and BD711 are respectively complement to type BD708 and BD712

**APPLICATIONS**

- Intended for use in power linear and switching applications.

**PINNING**

PIN	DESCRIPTION
1	Base
2	Collector; connected to mounting base
3	Emitter

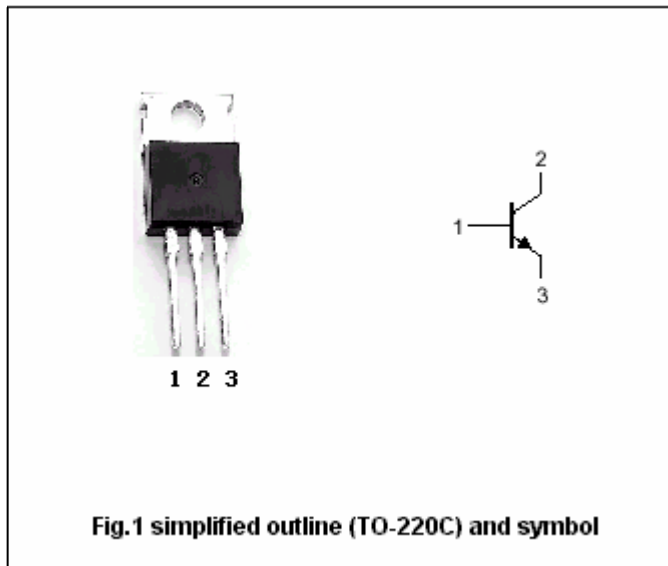

**Absolute maximum ratings(Ta=25 )**

SYMBOL	PARAMETER	CONDITIONS	VALUE	UNIT
V <sub>CBO</sub>	Collector-base voltage	BD707	60	V
		BD709	80	
		BD711	100	
V <sub>CEO</sub>	Collector-emitter voltage	BD707	60	
		BD709	80	
		BD711	100	
V <sub>EBO</sub>	Emitter-base voltage	Open collector	5	V
I <sub>C</sub>	Collector current-DC		12	A
I <sub>CM</sub>	Collector current-Pulse		18	A
I <sub>B</sub>	Base current		5	A
P <sub>T</sub>	Total dissipation	T <sub>C</sub> =25	75	W
T <sub>j</sub>	Junction temperature		150	
T <sub>stg</sub>	Storage temperature		-65~150	

**THERMAL CHARACTERISTICS**

SYMBOL	PARAMETER	MAX	UNIT
R <sub>th j-c</sub>	Thermal resistance junction to case	1.67	/W

## Silicon NPN Power Transistors

## BD707 BD709 BD711

## CHARACTERISTICS

T<sub>j</sub>=25 unless otherwise specified

SYMBOL	PARAMETER		CONDITIONS	MIN	TYP.	MAX	UNIT
V <sub>CEO(SUS)</sub>	Collector-emitter sustaining voltage	BD707	I <sub>C</sub> =0.1A, I <sub>B</sub> =0	60			V
		BD709		80			
		BD711		100			
V <sub>CEsat</sub>	Collector-emitter saturation voltage		I <sub>C</sub> =4A, I <sub>B</sub> =0.4A			1.0	V
V <sub>BE</sub>	Base-emitter voltage		I <sub>C</sub> =4A, V <sub>CE</sub> =4V			1.5	V
I <sub>CBO</sub>	Collector cut-off current	BD707	V <sub>CB</sub> =60V, I <sub>E</sub> =0 T <sub>C</sub> =150			0.1 1.0	mA
		BD709	V <sub>CB</sub> =80V, I <sub>E</sub> =0 T <sub>C</sub> =150			0.1 1.0	
		BD711	V <sub>CB</sub> =100V, I <sub>E</sub> =0 T <sub>C</sub> =150			0.1 1.0	
I <sub>CEO</sub>	Collector cut-off current	BD707	V <sub>CE</sub> =30V, I <sub>B</sub> =0			0.1	mA
		BD709	V <sub>CE</sub> =40V, I <sub>B</sub> =0				
		BD711	V <sub>CE</sub> =50V, I <sub>B</sub> =0				
I <sub>EBO</sub>	Emitter cut-off current		V <sub>EB</sub> =5V; I <sub>C</sub> =0			1.0	mA
h <sub>FE-1</sub>	DC current gain		I <sub>C</sub> =0.5A; V <sub>CE</sub> =2V	40	120	400	
h <sub>FE-2</sub>	DC current gain only for <b>BD707/709</b>		I <sub>C</sub> =2A; V <sub>CE</sub> =2V	30			
h <sub>FE-3</sub>	DC current gain		I <sub>C</sub> =4A; V <sub>CE</sub> =2V	15		150	
h <sub>FE-4</sub>	DC current gain	BD707	I <sub>C</sub> =10A; V <sub>CE</sub> =4V	5	10		
		BD709		8			
		BD711		8			
f <sub>T</sub>	Transition frequency		I <sub>C</sub> =0.3A; V <sub>CE</sub> =3V;	3			MHz

Silicon NPN Power Transistors

BD707 BD709 BD711

PACKAGE OUTLINE

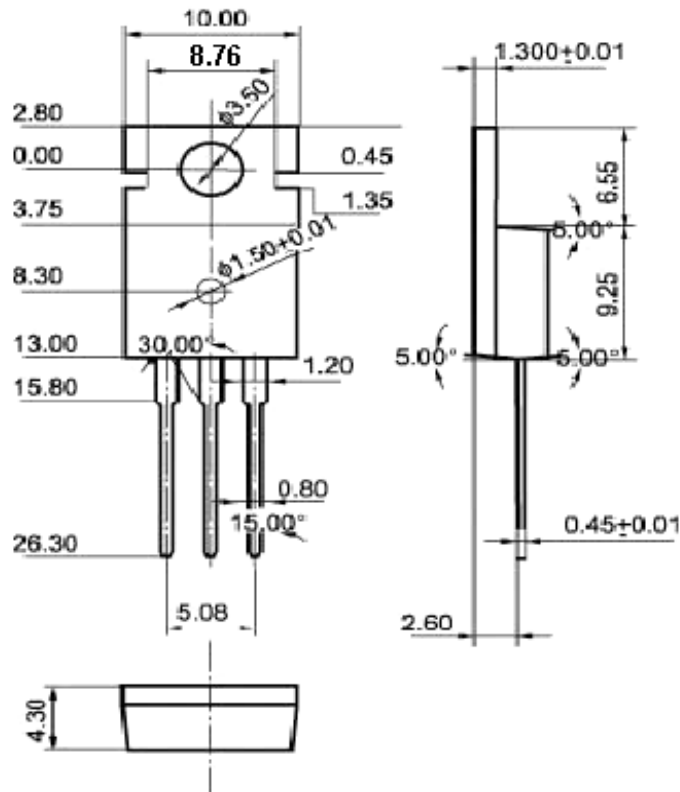

Fig.2 Outline dimensions