

DATA SHEET

TDA4686

Video processor with automatic
cut-off control

Product specification
Supersedes data of May 1993
File under Integrated Circuits, IC02

1997 Jun 23

Video processor with automatic cut-off control

TDA4686

FEATURES

- Intended for double line frequency application (100/120 Hz)
- Operates from an 8 V DC supply
- Black level clamping of the colour difference, luminance and RGB input signals with coupling-capacitor DC level storage
- Two analog RGB inputs, selected either by fast switch signals or via I²C-bus; brightness and contrast control of both RGB inputs
- Saturation, contrast, brightness and white adjustment via I²C-bus
- Same RGB output black levels for Y/CD and RGB input signals
- Timing pulse generation from either a 2 or 3-level sandcastle pulse for clamping, vertical synchronization and cut-off timing pulses
- Automatic cut-off control or clamped output selectable via I²C-bus
- Automatic cut-off control with picture tube leakage current compensation
- Cut-off measurement pulses after end of the vertical blanking pulse or end of an extra vertical flyback pulse
- Increased RGB signal bandwidths
- Two switch-on delays to prevent discolouration before steady-state operation
- Average beam current and peak drive limiting
- PAL/SECAM or NTSC matrix selection via I²C-bus
- Emitter-follower RGB output stages to drive the video output stages
- I²C-bus controlled DC output e.g. for hue-adjust of NTSC (multistandard) decoders
- No delay of clamping pulse
- Large luminance, colour difference and RGB bandwidth.

GENERAL DESCRIPTION

The TDA4686 is a monolithic integrated circuit with a luminance and a colour difference interface for video processing in TV receivers. Its primary function is to process the luminance and colour difference signals from a colour decoder which is equipped e.g. with the multistandard decoder TDA4655 or TDA9160 plus delay line TDA4661 and the Picture Signal Improvement (PSI) IC, TDA467X, or from a feature module.



The required input signals are:

- Luminance and negative colour difference signals
- 2 or 3-level sandcastle pulse for internal timing pulse generation
- I²C-bus data and clock signals for microcontroller control.

Two sets of analog RGB colour signals can also be inserted, e.g. one from a peritelevision connector and the other from an on-screen display generator. The TDA4686 includes full I²C-bus control of all parameters and functions with automatic cut-off control of the picture tube cathode currents. It provides RGB output signals for the video output stages.

The TDA4686 is a simplified, pin compatible (except for pin 18) version of the TDA4680. The module address via I²C-bus can be used for both ICs; where a function is not included in the TDA4686 the I²C-bus command is not executed. The differences with the TDA4680 are:

- No automatic white level control; the white levels are determined directly by the I²C-bus data
- RGB reference levels for automatic cut-off control are not adjustable via I²C-bus
- No clamping delay
- Only contrast and brightness adjust for the RGB input signals
- The measurement lines are triggered either by the trailing edge of the vertical component of the sandcastle pulse or by the trailing edge of an optional external vertical flyback pulse (on pin 18), according to which occurs first.

The TDA4685 is like TDA4686 but intended for normal line frequency application.

Video processor with automatic cut-off control

TDA4686

QUICK REFERENCE DATA

SYMBOL	PARAMETER	MIN.	TYP.	MAX.	UNIT
V_P	supply voltage (pin 5)	7.2	8.0	8.8	V
I_P	supply current (pin 5)	–	60	–	mA
$V_{8(p-p)}$	luminance input (peak-to-peak value)	–	0.45	–	V
$V_{6(p-p)}$	–(B – Y) input (peak-to-peak value)	–	1.33	–	V
$V_{7(p-p)}$	–(R – Y) input (peak-to-peak value)	–	1.05	–	V
V_{14}	3-level sandcastle pulse				
	H + V	–	2.5	–	V
	H	–	4.5	–	V
	BK	–	8.0	–	V
	2-level sandcastle pulse				
	H + V	–	2.5	–	V
	BK	–	4.5	–	V
$V_{i(p-p)}$	RGB input signals at pins 2, 3, 4, 10, 11 and 12 (peak-to-peak value)	–	0.7	–	V
$V_{o(b-w)}$	RGB outputs at pins 24, 22 and 20 (black-to-white value)	–	2.0	–	V
T_{amb}	operating ambient temperature	0	–	70	°C

ORDERING INFORMATION

TYPE NUMBER	PACKAGE		
	NAME	DESCRIPTION	VERSION
TDA4686	DIP28	plastic dual in-line package; 28 leads (600 mil)	SOT117-1
TDA4686WP	PLCC28	plastic leaded chip carrier; 28 leads	SOT261-2

Video processor with automatic cut-off control

TDA4686

PINNING

SYMBOL	PIN	DESCRIPTION
FSW ₂	1	fast switch 2 input
R ₂	2	red input 2
G ₂	3	green input 2
B ₂	4	blue input 2
V _P	5	supply voltage
-(B - Y)	6	colour difference input -(B - Y)
-(R - Y)	7	colour difference input -(R - Y)
Y	8	luminance input
GND	9	ground
R ₁	10	red input 1
G ₁	11	green input 1
B ₁	12	blue input 1
FSW ₁	13	fast switch 1 input
SC	14	sandcastle pulse input
BCL	15	average beam current limiting input

SYMBOL	PIN	DESCRIPTION
C _{PD} L	16	storage capacitor for peak drive limiting
C _L	17	storage capacitor for leakage current
VFB	18	vertical flyback pulse input
CI	19	cut-off measurement input
B _O	20	blue output
C _B	21	blue cut-off storage capacitor
G _O	22	green output
C _G	23	green cut-off storage capacitor
R _O	24	red output
C _R	25	red cut-off storage capacitor
HUE	26	hue control output
SDA	27	I ² C-bus serial data input; acknowledge output
SCL	28	I ² C-bus serial clock input

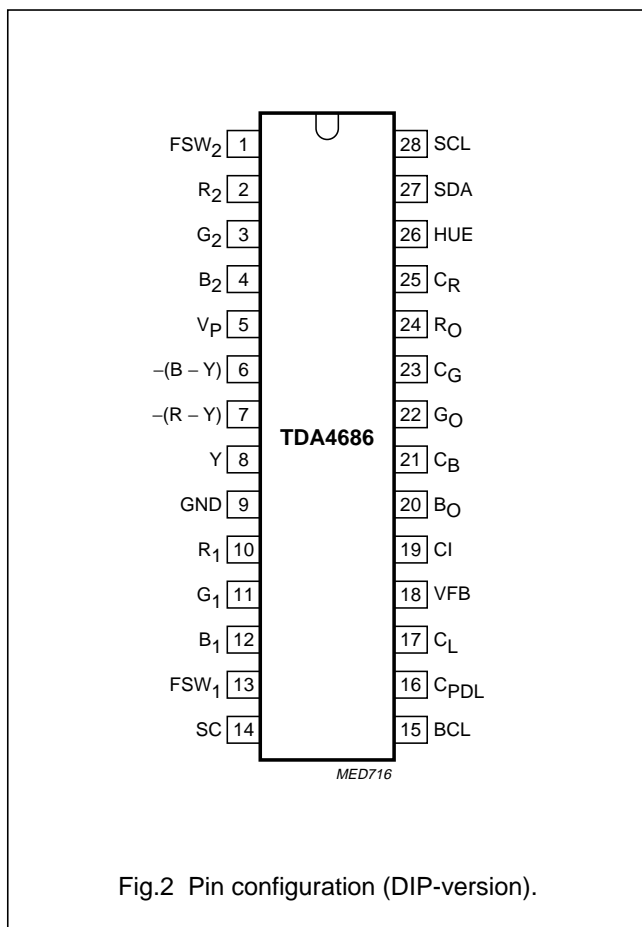

Fig.2 Pin configuration (DIP-version).

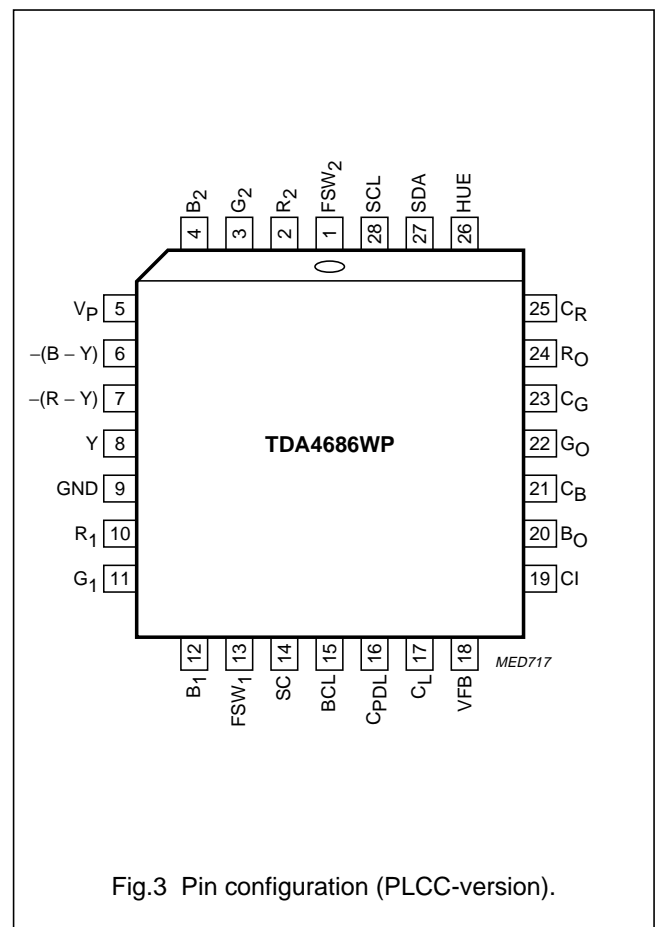

Fig.3 Pin configuration (PLCC-version).

Video processor with automatic cut-off control

TDA4686

I²C-BUS PROTOCOL

Control

The I²C-bus transmitter provides the data bytes to select and adjust the following functions and parameters:

- Brightness adjust
- Saturation adjust
- Contrast adjust
- DC output e.g. for hue control
- RGB gain adjust
- Peak drive limiting level adjust
- Selects either 3-level or 2-level (5 V) sandcastle pulse
- Enables cut-off control; enables output clamping
- Selects either PAL/SECAM or NTSC matrix
- Enables/disables synchronization of the execution of I²C-bus commands with the vertical blanking interval
- Enables Y/CD, RGB₁ or RGB₂ input.

I²C-bus transmitter and data transfer

I²C-BUS SPECIFICATION

The I²C-bus is a bidirectional, two-wire, serial data bus for intercommunication between ICs in an equipment.

The microcontroller transmits data to the I²C-bus receiver in the TDA4686 over the serial data line SDA (pin 27) synchronized by the serial clock line SCL (pin 28). Both lines are normally connected to a positive voltage supply through pull-up resistors. Data is transferred when the SCL line is LOW. When SCL is HIGH the serial data line SDA must be stable. A HIGH-to-LOW transition of the SDA line when SCL is HIGH is defined as a START bit. A LOW-to-HIGH transition of the SDA line when SCL is HIGH is defined as a STOP bit.

Each transmission must start with a START bit and end with a STOP bit. The bus is busy after a START bit and is only free again after a STOP bit has been transmitted.

I²C-BUS RECEIVER (MICROCONTROLLER WRITE MODE)

Each transmission to the I²C-bus receiver consists of at least three bytes following the START bit. Each byte is acknowledged by an acknowledge bit immediately following each byte. The first byte is the Module Address (MAD) byte, also called slave address byte. This includes the module address, 1000100 for the TDA4686. The TDA4686 is a slave receiver ($R/\overline{W} = 0$), therefore the module address byte is 10001000 (88H; see also Fig.4).

The length of a data transmission is unrestricted, but the module address and the correct subaddress must be transmitted before the data byte(s). The order of data transmission is shown in Figs 5 and 6.

Without auto-increment (BREN = 0 or 1) the module address (MAD) byte is followed by a SubAddress (SAD) byte and one data byte only (see Fig.5).

Video processor with automatic cut-off control

TDA4686

AUTO-INCREMENT

The auto-increment format enables quick slave receiver initialization by one transmission, when the I²C-bus control bit BREN = 0 (see control register bits of Table 1).

If BREN = 1 auto-increment is not possible.

If the auto-increment format is selected, the MAD byte is followed by a SAD byte and by the data bytes of consecutive subaddresses (see Fig.6).

All subaddresses from 00H to 0FH are automatically incremented, the subaddress counter wraps round from 0FH to 00H. Reserved subaddresses 07H, 08H, 09H, 0BH, 0EH and 0FH are treated as legal but have no effect. Subaddresses outside the range 00H and 0FH are not acknowledged by the device.

Subaddresses are stored in the TDA4686 to address the following parameters and functions (see Table 1):

- Brightness adjust
- Saturation adjust
- Contrast adjust
- Hue control voltage
- RGB gain adjust
- Peak drive limiting adjust
- Control register functions.

The data bytes D7 to D0 (see Table 1) provide the data of the parameters and functions for video processing.

CONTROL REGISTER 1

NMEN (NTSC Matrix Enable):

0 = PAL/SECAM matrix

1 = NTSC matrix.

BREN (Buffer Register Enable):

0 = new data is executed as soon as it is received

1 = data is stored in buffer registers and is transferred to the data registers during the next vertical blanking interval.

The I²C-bus receiver does not accept any new data until this data is transferred into the data registers.

SC5 (SandCastle 5 V):

0 = 3-level sandcastle pulse

1 = 2-level (5 V) sandcastle pulse.

CONTROL REGISTER 2

FSON2 (Fast Switch 2 ON).

FSDIS2 (Fast Switch 2 Disable).

FSON1 (Fast Switch 1 ON).

FSDIS1 (Fast Switch 1 Disable).

The RGB input signals are selected by FSON2 and FSON1 or FSW₂ and FSW₁:

- FSON2 has priority over FSON1
- FSW₂ has priority over FSW₁
- FSDIS1 and FSDIS2 disable FSW₁ and FSW₂ (see Table 2).

BCOF (Black level Control Off):

0 = automatic cut-off control enabled

1 = automatic cut-off control disabled; RGB outputs are clamped to fixed DC levels.

When the supply voltage has dropped below approximately 6.0 V (usually occurs when the TV receiver is switched on or the supply voltage is interrupted) all data and function bits are set to 01H.

Video processor with automatic cut-off control

TDA4686

Table 1 Subaddress (SAD) and data bytes; note 1

FUNCTION	SAD (HEX)	MSB								LSB	
		D7	D6	D5	D4	D3	D2	D1	D0		
Brightness	00	0	0	A05	A04	A03	A02	A01	A00		
Saturation	01	0	0	A15	A14	A13	A12	A11	A10		
Contrast	02	0	0	A25	A24	A23	A22	A21	A20		
Hue control voltage	03	0	0	A35	A34	A33	A32	A31	A30		
Red gain	04	0	0	A45	A44	A43	A42	A41	A40		
Green gain	05	0	0	A55	A54	A53	A52	A51	A50		
Blue gain	06	0	0	A65	A64	A63	A62	A61	A60		
Reserved	07	0	0	X	X	X	X	X	X		
Reserved	08	0	0	X	X	X	X	X	X		
Reserved	09	0	0	X	X	X	X	X	X		
Peak drive limit	0A	0	0	AA5	AA4	AA3	AA2	AA1	AA0		
Reserved	0B	X	X	X	X	X	X	X	X		
Control register 1	0C	SC5	X	BREN	X	NMEN	X	X	X		
Control register 2	0D	X	X	X	BCOF	FSDIS2	FSON2	FSDIS1	FSON1		
Reserved	0E	X	X	X	X	X	X	X	X		
Reserved	0F	X	X	X	X	X	X	X	X		

Note

1. X = don't care, but for software compatibility with other or future video ICs it is recommended to set all X to logic 0.

Video processor with automatic cut-off control

TDA4686

Table 2 Signal input selection by the fast source switches; notes 1 to 4

I ² C-BUS CONTROL BITS				ANALOG SWITCH SIGNALS		INPUT SELECTED		
FSON2	FSDIS2	FSON1	FSDIS1	FSW ₂ (PIN 1)	FSW ₁ (PIN 13)	RGB ₂	RGB ₁	Y/CD
L	L	L	L	L	L			ON
				L	H		ON	
				H	X	ON		
L	L	L	H	L	X			ON
				H	X	ON		
L	L	H	X	L	X		ON	
				H	X	ON		
L	H	L	L	X	L			ON
				X	H		ON	
L	H	L	H	X	X			ON
L	H	H	X	X	X		ON	
H	X	X	X	X	X	ON		

Notes

1. H: logic HIGH implies that the voltage >0.9 V.
2. L: logic LOW implies that the voltage <0.4 V.
3. X = don't care.
4. ON indicates the selected input signal.

LIMITING VALUES

In accordance with the Absolute Maximum Rating System (IEC 134).

SYMBOL	PARAMETER	MIN.	MAX.	UNIT
V _P	supply voltage (pin 5)	–	8.8	V
V _i	input voltage (pins 1 to 8, 10 to 13, 16, 21, 23 and 25)	–0.1	+V _P	V
	input voltage (pins 15, 18 and 19)	–0.7	V _P + 0.7	V
	input voltage (pins 27 and 28)	–0.1	+8.8	V
V ₁₄	sandcastle pulse voltage	–0.7	V _P + 5.8	V
I _{av}	average current (pins 20, 22 and 24)	–10	+4	mA
I _M	peak current (pins 20, 22 and 24)	–20	+4	mA
I ₂₆	output current	–8	+0.6	mA
T _{stg}	storage temperature	–20	+150	°C
T _{amb}	operating ambient temperature	0	70	°C
P _{tot}	total power dissipation			
	SOT117-1	–	1.2	W
	SOT261-2	–	1.0	W

Video processor with automatic cut-off control

TDA4686

CHARACTERISTICS

All voltages are measured in test circuit of Fig.10 with respect to GND (pin 9); $V_P = 8.0$ V; $T_{amb} = 25$ °C; nominal signal amplitudes (black-to-white) at output pins 24, 22 and 20; nominal settings of brightness, contrast, saturation and white level control; without beam current or peak drive limiting; unless otherwise specified.

SYMBOL	PARAMETER	CONDITIONS	MIN.	TYP.	MAX.	UNIT
Supply (pin 5)						
V_P	supply voltage		7.2	8.0	8.8	V
I_P	supply current		–	60	–	mA
Colour difference inputs [–(B – Y): pin 6; –(R – Y): pin 7]						
$V_{6(p-p)}$	–(B – Y) input (peak-to-peak value)	notes 1 and 2	–	1.33	–	V
$V_{7(p-p)}$	–(R – Y) input (peak-to-peak value)	notes 1 and 2	–	1.05	–	V
$V_{6,7}$	internal DC bias voltage	at black level clamping	–	4.1	–	V
$ I_{6,7} $	input current	during line scan	–	–	0.1	μ A
		at black level clamping	100	–	–	μ A
$R_{6,7}$	input resistance		10	–	–	M Ω
Luminance/sync (VBS; Y: pin 8)						
$V_{i(p-p)}$	luminance input voltage at pin 8 (peak-to-peak value)	note 2	–	0.45	–	V
$V_{8(bias)}$	internal DC bias voltage	at black level clamping	–	4.1	–	V
$ I_8 $	input current	during line scan	–	–	0.1	μ A
		at black level clamping	100	–	–	μ A
R_8	input resistance		10	–	–	M Ω
RGB input 1 (R_1: pin 10; G_1: pin 11; B_1: pin 12)						
$V_{i(p-p)}$	input voltage at pins 10, 11 and 12 (peak-to-peak value)	note 2	–	0.7	–	V
$V_{10/11/12(bias)}$	internal DC bias voltage	at black level clamping	–	5.7	–	V
$ I_{10/11/12} $	input current	during line scan	–	–	0.1	μ A
		at black level clamping	100	–	–	μ A
$R_{10/11/12}$	input resistance		10	–	–	M Ω
RGB input 2 (R_2: pin 2, G_2: pin 3, B_2: pin 4)						
$V_{i(p-p)}$	input voltage at pins 2, 3 and 4 (peak-to-peak value)	note 2	–	0.7	–	V
$V_{2/3/4}$	internal DC bias voltage	at black level clamping	–	5.7	–	V
$ I_{2/3/4} $	input current	during line scan	–	–	0.1	μ A
		at black level clamping	100	–	–	μ A
$R_{2/3/4}$	input resistance		10	–	–	M Ω

Video processor with automatic cut-off control

TDA4686

SYMBOL	PARAMETER	CONDITIONS	MIN.	TYP.	MAX.	UNIT
Fast signal switch FSW₁ (pin 13) to select Y, CD or R₁, G₁, B₁ inputs (control bits: see Table 2)						
V ₁₃	voltage to select Y and CD		–	–	0.4	V
	voltage to select R ₁ , G ₁ , B ₁		0.9	–	5.0	V
R ₁₃	internal resistance to ground		–	4.0	–	kΩ
Δt	difference between transit times for signal switching and signal insertion		–	–	10	ns
Fast signal switch FSW₂ (pin 1) to select Y, CD/R₁, G₁, B₁ or R₂, G₂, B₂ inputs (control bits: see Table 2)						
V ₁	voltage to select Y, CD/R ₁ , G ₁ , B ₁		–	–	0.4	V
	voltage to select R ₂ , G ₂ , B ₂		0.9	–	5.0	V
R ₁	internal resistance to ground		–	4.0	–	kΩ
Δt	difference between transit times for signal switching and signal insertion		–	–	10	ns
Saturation adjust [acts on –(R – Y) and –(B – Y) signals under I²C-bus control; subaddress 01H (bit resolution 1.5% of maximum saturation); data byte 3FH for maximum saturation, data byte 23H for nominal saturation and data byte 00H for minimum saturation]						
d _s	saturation below maximum	at 23H	–	5	–	dB
		at 00H; f = 100 kHz	–	50	–	dB
Contrast adjust [acts on internal RGB signals under I²C-bus control; subaddress 02H (bit resolution 1.5% of maximum contrast); data byte 3FH for maximum contrast, data byte 22H for nominal contrast and data byte 00H for minimum contrast]						
d _c	contrast below maximum	at 22H	–	5	–	dB
		at 00H	–	22	–	dB
Brightness adjust [acts on internal RGB signals under I²C-bus control; subaddress 00H (bit resolution 1.5% of maximum brightness); data byte 3FH for maximum brightness, data byte 26H for nominal brightness and data byte 00H for minimum brightness]						
d _{br}	black level shift of nominal signal amplitude referred to cut-off measurement level	at 3FH	–	30	–	%
		at 00H	–	–50	–	%
White potentiometers [under I²C-bus control; subaddresses 04H (red), 05H (green) and 06H (blue); data byte 3FH for maximum gain; data byte 19H for nominal gain and data byte 00H for minimum gain]; note 3						
ΔG _v	relative to nominal gain					
	increase of gain	at 3FH	–	50	–	%
	decrease of gain	at 00H	–	50	–	%

Video processor with automatic cut-off control

TDA4686

SYMBOL	PARAMETER	CONDITIONS	MIN.	TYP.	MAX.	UNIT
RGB outputs (pins 24, 22 and 20; positive going output signals; peak drive limiter set = 3FH); note 4						
$V_{o(b-w)}$	nominal output signals (black-to-white value)		–	2.0	–	V
	maximum output signals (black-to-white value)		3.0	–	–	V
ΔV_o	spread between RGB output signals		–	–	10	%
V_o	minimum output voltages		–	–	0.8	V
	maximum output voltages		6.8	–	–	V
$V_{24,22,20}$	voltage of cut-off measurement line equivalent to voltage during ultra-black	output clamping; BCOF = 1	2.3	2.5	2.7	V
I_{int}	internal current sources		–	5.0	–	mA
R_o	output resistance		–	20	–	Ω
Frequency response (measured with 10 MΩ, 30 pF external load)						
f_{res}	frequency response of Y path (from pin 8 to pins 24, 22 and 20)	$f = 14$ MHz	–	–	3	dB
	frequency response of CD path (from pins 7 to 24 and 6 to 20)	$f = 12$ MHz	–	–	3	dB
	frequency response of RGB ₁ path (from pins 10 to 24, 11 to 22 and 12 to 20)	$f = 22$ MHz	–	–	3	dB
	frequency response of RGB ₂ path (from pins 2 to 24, 3 to 22 and 4 to 20)	$f = 22$ MHz	–	–	3	dB
Sandcastle pulse detector (pin 14)						
CONTROL BIT SC5 = 0; 3-LEVEL; notes 5 and 6						
V_{14}	sandcastle pulse voltage					
	for horizontal and vertical blanking pulses		2.0	2.5	3.0	V
	for horizontal pulses (line count)		4.0	4.5	5.0	V
	for burst key pulses (clamping)		7.6	–	$V_P + 5.8$	V
CONTROL BIT SC5 = 1; 2-LEVEL; notes 5 and 6						
V_{14}	sandcastle pulse voltage					
	for horizontal and vertical blanking pulses		2.0	2.5	3.0	V
	for burst key pulses		4.0	4.5	$V_P + 5.8$	V
GENERAL						
I_{14}	output current	$V_{14} = 0$ V	–	–	–100	μ A
t_d	leading edge delay of the clamping pulse		–	0	–	μ s

Video processor with automatic cut-off control

TDA4686

SYMBOL	PARAMETER	CONDITIONS	MIN.	TYP.	MAX.	UNIT
Vertical flyback (pin 18); note 6						
V ₁₈	vertical flyback pulse	for LOW	–	–	2.5	V
		for HIGH	4.5	–	–	V
	internal voltage	pin 18 open-circuit; note 7	–	5.0	–	V
I ₁₈	input current		–	–	5	μA
Average beam current limiting (pin 15); note 8						
V _{c(15)}	contrast reduction starting voltage		–	4.0	–	V
ΔV _{c(15)}	voltage difference for full contrast reduction		–	–2.0	–	V
V _{br(15)}	brightness reduction starting voltage		–	2.5	–	V
ΔV _{br(15)}	voltage difference for full brightness reduction		–	–1.6	–	V
Peak drive limiting voltage [pin 16; internal peak drive limiting level (V_{pdl}) acts on RGB outputs under I²C-bus control; subaddress 0AH]; note 9						
V _{20,22,24}	minimum RGB output voltages	at 00H	–	–	3.0	V
	maximum RGB output voltages	at 3FH	7.0	–	–	V
I ₁₆	charge current		–	–1	–	μA
	discharge current	during peak white	–	5	–	mA
V ₁₆	internal voltage limitation		4.5	–	–	V
V _{c(16)}	contrast reduction starting voltage		–	4.0	–	V
ΔV _{c(16)}	voltage difference for full contrast reduction		–	–2.0	–	V
V _{br(16)}	brightness reduction starting voltage		–	2.5	–	V
ΔV _{br(16)}	voltage difference for full brightness reduction		–	–1.6	–	V
Automatic cut-off control (pin 19); notes 6 and 10 to 12; see Fig.8						
V ₁₉	external voltage		–	–	V _P – 1.4	V
I ₁₉	output current		–	–	–60	μA
	input current		150	–	–	μA
	additional input current	switch-on delay 1	–	0.5	–	mA
V _{24,22,20}	monitor pulse amplitude (under I ² C-bus control; subaddress 0AH)	switch-on delay 1; note 11	–	V _{pdl} – 1.0	–	V
V _{19(th)}	voltage threshold for picture tube cathode warming up	switch-on delay 1	–	4.5	–	V
V _{ref}	internally controlled voltage	during leakage measurement period	–	2.7	–	V
ΔV ₁₉	difference between V _{MEAS} (cut-off measurement voltage) and V _{ref}		–	1.0	–	V

Video processor with automatic cut-off control

TDA4686

SYMBOL	PARAMETER	CONDITIONS	MIN.	TYP.	MAX.	UNIT
Cut-off storage (pins 25, 23 and 21)						
$I_{21,23,25}$	charge and discharge currents	during cut-off measurement lines	–	0.3	–	mA
	input currents of storage inputs	outside measurement time	–	–	0.1	μ A
Storage of leakage information (pin 17)						
I_{17}	charge and discharge currents	during leakage measurement period	–	0.4	–	mA
	leakage current	outside measurement time	–	–	0.1	μ A
V_{17}	threshold voltage for reset to switch-on state		–	2.5	–	V
Hue control (under I²C-bus control; subaddress 03H; data byte 3FH for maximum voltage; data byte 20H for nominal voltage and data byte 00H for minimum voltage); note 13						
V_{26}	output voltage	at 3FH	4.8	–	–	V
		at 20H	–	3.0	–	V
		at 00H	–	–	1.2	V
I_{int}	current of the internal current source at pin 26		500	–	–	μ A
I²C-bus receiver clock SCL (pin 28)						
f_{SCL}	input frequency range		0	–	100	kHz
V_{IL}	LOW-level input voltage		–	–	1.5	V
V_{IH}	HIGH-level input voltage		3.0	–	6.0	V
I_{IL}	LOW-level input current		–	–	–10	μ A
I_{IH}	HIGH-level input current		–	–	10	μ A
t_L	clock pulse LOW		4.7	–	–	μ s
t_H	clock pulse HIGH		4.0	–	–	μ s
t_r	rise time		–	–	1.0	μ s
t_f	fall time		–	–	0.3	μ s
I²C-bus receiver data input/output SDA (pin 27)						
V_{IL}	LOW-level input voltage		–	–	1.5	V
V_{IH}	HIGH-level input voltage		3.0	–	6.0	V
I_{IL}	LOW-level input current		–	–	–10	μ A
I_{IH}	HIGH-level input current		–	–	10	μ A
I_{OL}	LOW-level output current		3.0	–	–	mA
t_r	rise time		–	–	1.0	μ s
t_f	fall time		–	–	0.3	μ s
$t_{SU;DAT}$	data set-up time		0.25	–	–	μ s

Video processor with automatic cut-off control

TDA4686

Notes to the characteristics

1. The values of the $-(B - Y)$ and $-(R - Y)$ colour difference input signals are for a 75% colour-bar signal.
2. The pins are capacitively coupled to a low ohmic source, with a recommended maximum output impedance of 600 Ω .
3. The white potentiometers affect the amplitudes of the RGB output signals.
4. The RGB outputs at pins 24, 22 and 20 are emitter followers with current sources.
5. Sandcastle pulses are compared with internal threshold voltages independent of V_p . The threshold voltages separate the components of the sandcastle pulse. The particular component is generated when the voltage on pin 14 exceeds the defined internal threshold voltage.
The internal threshold voltages (control bit SC5 = 0) are:
 - 1.5 V for horizontal and vertical blanking pulses
 - 3.5 V for horizontal pulses
 - 6.5 V for the burst key pulse.The internal threshold voltages (control bit SC5 = 1) are:
 - 1.5 V for horizontal and vertical blanking pulses
 - 3.5 V for the burst key pulse.
6. Vertical signal blanking is determined by the vertical component of the sandcastle pulse. The leakage and the RGB cut-off measurement lines are positioned in the first four complete lines after the end of the vertical component. In this case, the RGB output signals are blanked until the end of the last measurement line; see Fig.8a. If an extra vertical flyback pulse VFB is applied to pin 18, the four measurement lines start in the first complete line after the end of the VFB pulse; see Fig.8b. In this case, the output signals are blanked either until the end of the last measurement line or until the end of the vertical component of the sandcastle pulse, according to which occurs last.
7. If no VFB pulse is applied, pin 18 can be left open-circuit or connected to V_p . If pin 18 is always LOW neither automatic cut-off control nor output clamping can happen.
8. Average beam current limiting reduces the contrast, at minimum contrast it reduces the brightness.
9. Peak drive limiting reduces the RGB outputs by reducing the contrast, at minimum contrast it reduces the brightness. The maximum RGB outputs are determined via the I²C-bus under subaddress 0AH. When an RGB output exceeds the maximum voltage, peak drive limiting is delayed by one horizontal line.
10. During leakage current measurement, the RGB channels are blanked to ultra-black level. During cut-off measurement one channel is set to the measurement pulse level, the other channels are blanked to ultra-black. Since the brightness adjust shifts the colour signal relative to the black level, the brightness adjust is disabled during the vertical blanking interval (see Figs 7 and 8).
11. During picture cathode warming up (first switch-on delay) the RGB outputs (pins 24, 22 and 20) are blanked to the ultra-black level during line scan. During the vertical blanking interval a white-level monitor pulse is fed out on the RGB outputs and the cathode currents are measured. When the voltage threshold on pin 19 is greater than 4.5 V, the monitor pulse is switched off and cut-off control is activated (second switch-on delay). As soon as cut-off control stabilizes, RGB output blanking is removed.
12. Range of cut-off measurement level at the RGB outputs is 1 to 5 V. The recommended value is 3 V.
13. The hue control output at pin 26 is an emitter follower with current source.

Video processor with automatic cut-off control

TDA4686

Table 3 Demodulator axes and amplification factors

PARAMETER	NTSC	PAL
(B - Y)* demodulator axis	0°	0°
(R - Y)* demodulator axis	115°	90°
(R - Y)* amplification factor	1.97	1.14
(B - Y)* amplification factor	2.03	2.03

Table 4 PAL/SECAM and NTSC matrix; note 1

MATRIX	NMEN
PAL/SECAM	0
NTSC	1

Note

- PAL/SECAM signals are matrixed by the equation: $V_{G-Y} = -0.51V_{R-Y} - 0.19V_{B-Y}$

NTSC signals are matrixed by the equations (hue phase shift of -5 degrees):

$V_{R-Y^*} = 1.57V_{R-Y} - 0.41V_{B-Y}$; $V_{G-Y^*} = -0.43V_{R-Y} - 0.11V_{B-Y}$; $V_{B-Y^*} = V_{B-Y}$

In the matrix equations: V_{R-Y} and V_{B-Y} are conventional PAL demodulation axes and amplitudes at the output of the NTSC demodulator. V_{G-Y^*} , V_{R-Y^*} and V_{B-Y^*} are the NTSC modified colour difference signals; this is equivalent to the demodulator axes and amplification factors shown in Table 3. $V_{G-Y^*} = -0.27V_{R-Y^*} - 0.22V_{B-Y^*}$.

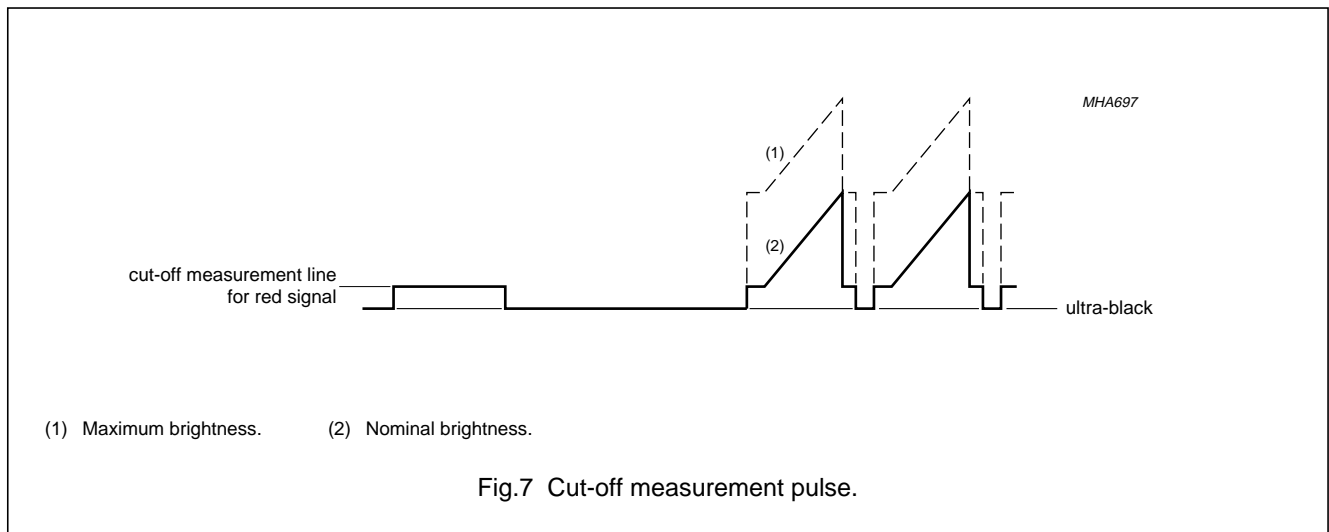

Video processor with automatic cut-off control

TDA4686

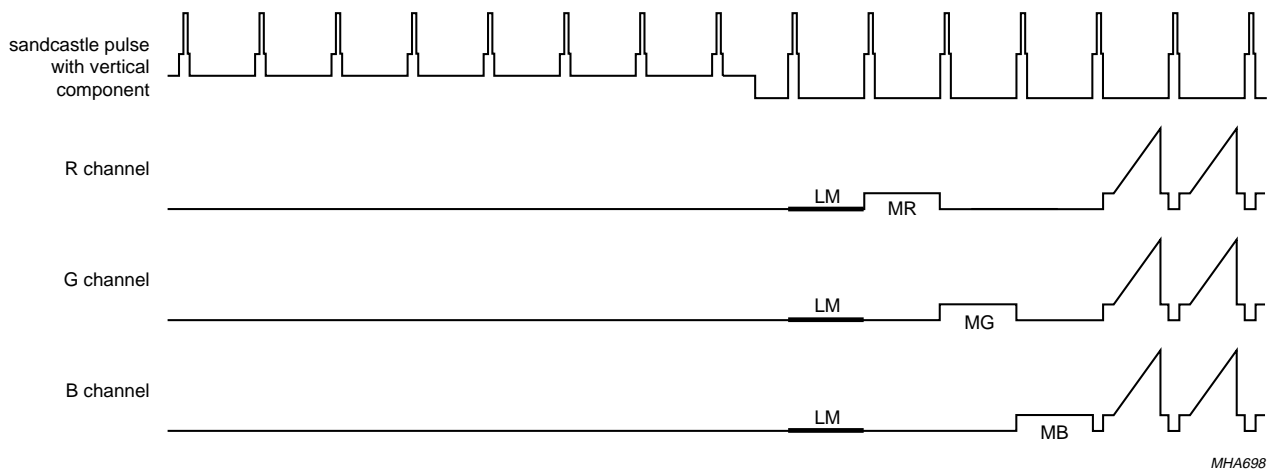

a. Timing controlled by sandcastle pulse.

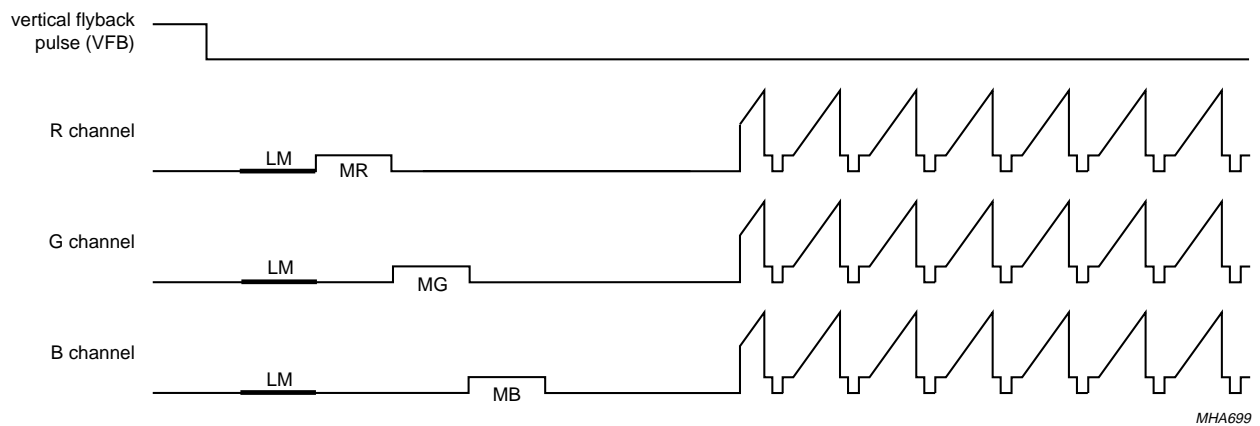

b. Timing controlled by additional vertical flyback pulse (VFB).

LM = leakage current measurement time.
 MR, MG, MB = R, G, B cut-off measurement pulses.

Fig.8 Leakage and cut-off current measurement timing diagram.

Video processor with automatic cut-off control

TDA4686

INTERNAL PIN CONFIGURATION

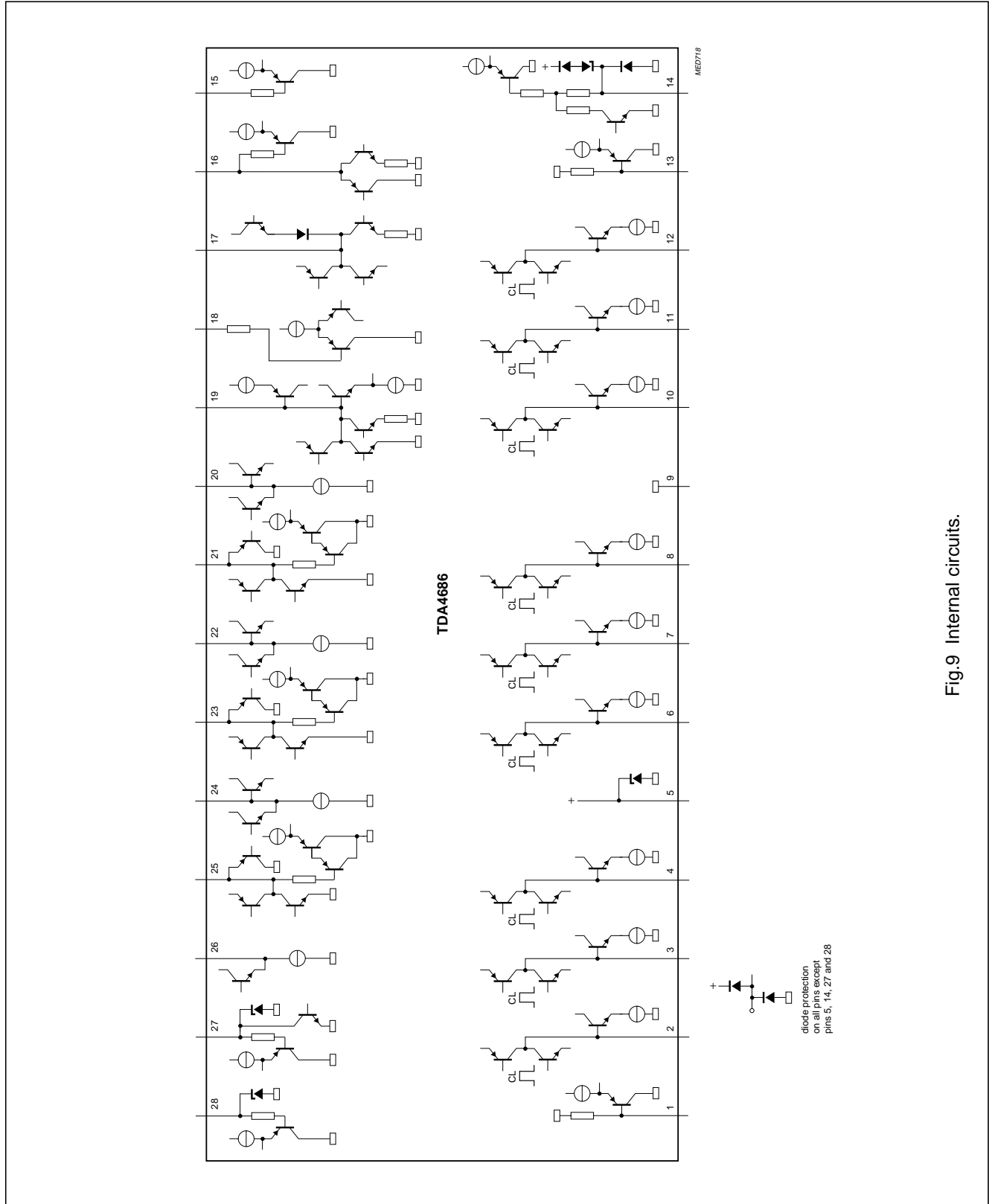

Fig.9 Internal circuits.

Video processor with automatic cut-off control

TDA4686

TEST AND APPLICATION INFORMATION

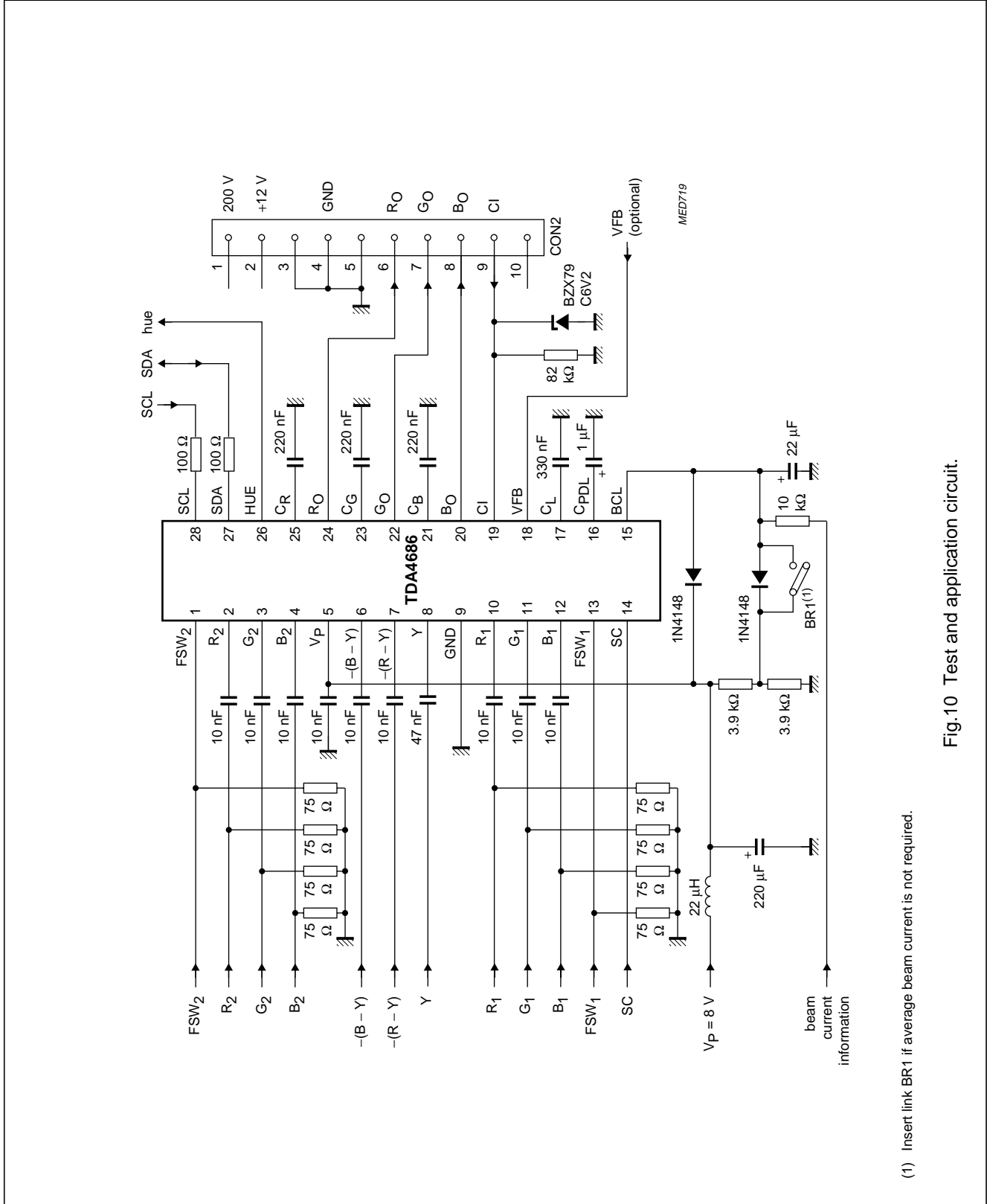

Fig.10 Test and application circuit.

(1) Insert link BR1 if average beam current is not required.

Video processor with automatic cut-off control

TDA4686

PACKAGE OUTLINES

DIP28: plastic dual in-line package; 28 leads (600 mil)

SOT117-1

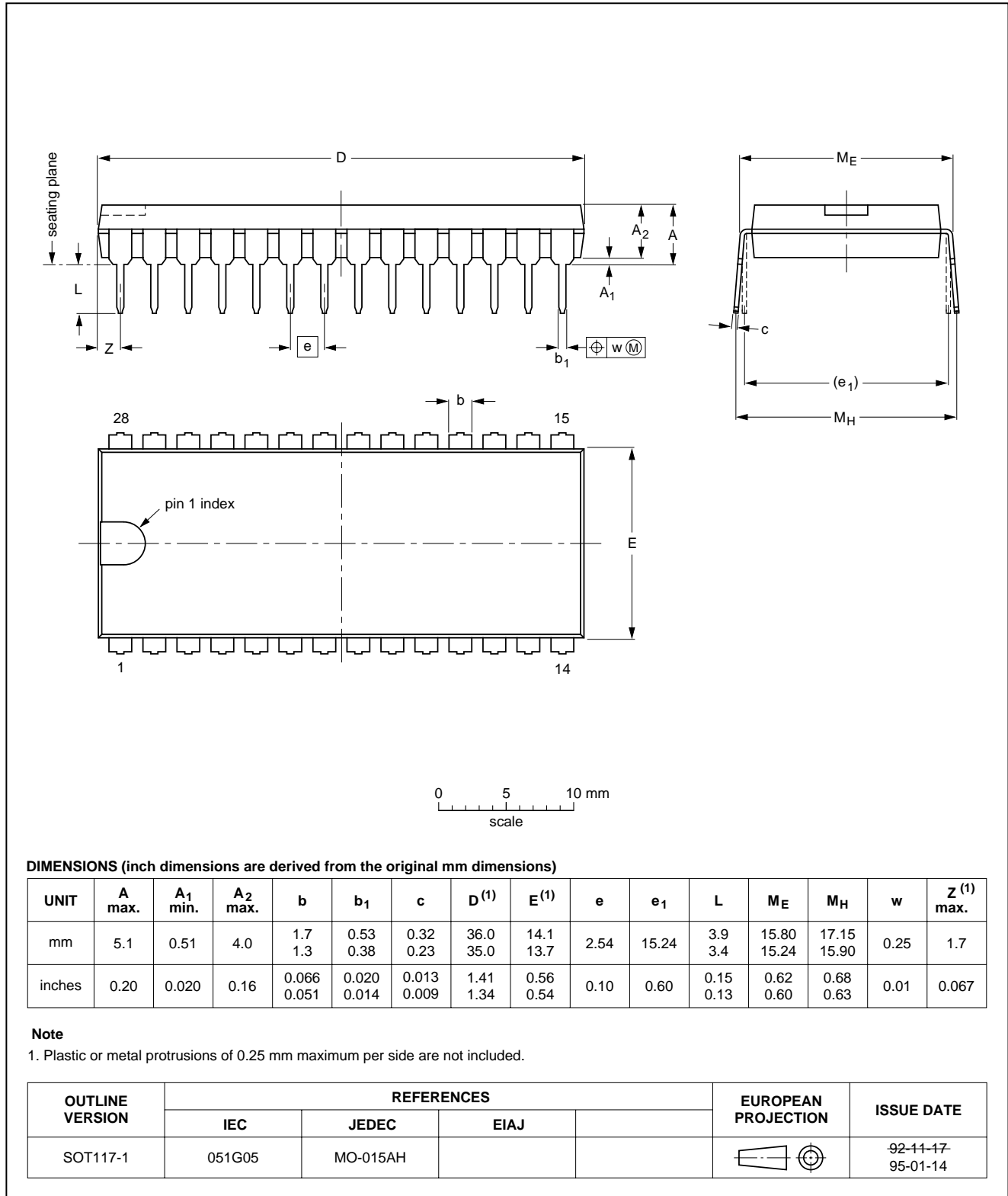

Video processor with automatic cut-off control

TDA4686

PLCC28: plastic leaded chip carrier; 28 leads

SOT261-2

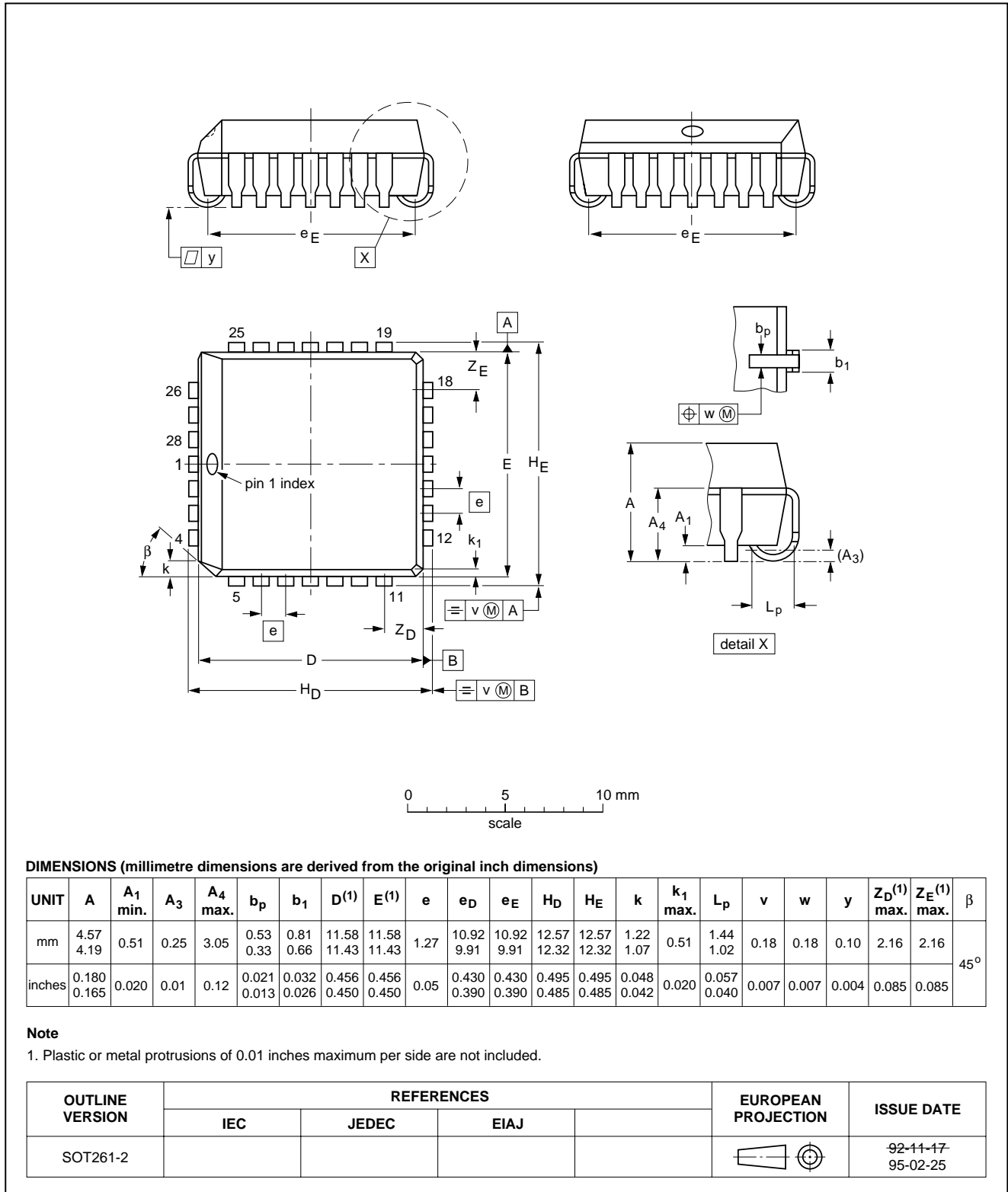

Video processor with automatic cut-off control

TDA4686

SOLDERING

Introduction

There is no soldering method that is ideal for all IC packages. Wave soldering is often preferred when through-hole and surface mounted components are mixed on one printed-circuit board. However, wave soldering is not always suitable for surface mounted ICs, or for printed-circuits with high population densities. In these situations reflow soldering is often used.

This text gives a very brief insight to a complex technology. A more in-depth account of soldering ICs can be found in our *"IC Package Databook"* (order code 9398 652 90011).

DIP

SOLDERING BY DIPPING OR BY WAVE

The maximum permissible temperature of the solder is 260 °C; solder at this temperature must not be in contact with the joint for more than 5 seconds. The total contact time of successive solder waves must not exceed 5 seconds.

The device may be mounted up to the seating plane, but the temperature of the plastic body must not exceed the specified maximum storage temperature ($T_{stg\ max}$). If the printed-circuit board has been pre-heated, forced cooling may be necessary immediately after soldering to keep the temperature within the permissible limit.

REPAIRING SOLDERED JOINTS

Apply a low voltage soldering iron (less than 24 V) to the lead(s) of the package, below the seating plane or not more than 2 mm above it. If the temperature of the soldering iron bit is less than 300 °C it may remain in contact for up to 10 seconds. If the bit temperature is between 300 and 400 °C, contact may be up to 5 seconds.

PLCC

REFLOW SOLDERING

Reflow soldering techniques are suitable for all PLCC packages.

The choice of heating method may be influenced by larger PLCC packages (44 leads, or more). If infrared or vapour phase heating is used and the large packages are not absolutely dry (less than 0.1% moisture content by weight), vaporization of the small amount of moisture in them can cause cracking of the plastic body. For more information, refer to the Drypack chapter in our *"Quality Reference Handbook"* (order code 9397 750 00192).

Reflow soldering requires solder paste (a suspension of fine solder particles, flux and binding agent) to be applied to the printed-circuit board by screen printing, stencilling or pressure-syringe dispensing before package placement.

Several techniques exist for reflowing; for example, thermal conduction by heated belt. Dwell times vary between 50 and 300 seconds depending on heating method. Typical reflow temperatures range from 215 to 250 °C.

Preheating is necessary to dry the paste and evaporate the binding agent. Preheating duration: 45 minutes at 45 °C.

WAVE SOLDERING

Wave soldering techniques can be used for all PLCC packages if the following conditions are observed:

- A double-wave (a turbulent wave with high upward pressure followed by a smooth laminar wave) soldering technique should be used.
- The longitudinal axis of the package footprint must be parallel to the solder flow.
- The package footprint must incorporate solder thieves at the downstream corners.

During placement and before soldering, the package must be fixed with a droplet of adhesive. The adhesive can be applied by screen printing, pin transfer or syringe dispensing. The package can be soldered after the adhesive is cured.

Maximum permissible solder temperature is 260 °C, and maximum duration of package immersion in solder is 10 seconds, if cooled to less than 150 °C within 6 seconds. Typical dwell time is 4 seconds at 250 °C.

A mildly-activated flux will eliminate the need for removal of corrosive residues in most applications.

REPAIRING SOLDERED JOINTS

Fix the component by first soldering two diagonally-opposite end leads. Use only a low voltage soldering iron (less than 24 V) applied to the flat part of the lead. Contact time must be limited to 10 seconds at up to 300 °C. When using a dedicated tool, all other leads can be soldered in one operation within 2 to 5 seconds between 270 and 320 °C.

Video processor with automatic cut-off control

TDA4686

DEFINITIONS

Data sheet status	
Objective specification	This data sheet contains target or goal specifications for product development.
Preliminary specification	This data sheet contains preliminary data; supplementary data may be published later.
Product specification	This data sheet contains final product specifications.
Limiting values	
Limiting values given are in accordance with the Absolute Maximum Rating System (IEC 134). Stress above one or more of the limiting values may cause permanent damage to the device. These are stress ratings only and operation of the device at these or at any other conditions above those given in the Characteristics sections of the specification is not implied. Exposure to limiting values for extended periods may affect device reliability.	
Application information	
Where application information is given, it is advisory and does not form part of the specification.	

LIFE SUPPORT APPLICATIONS

These products are not designed for use in life support appliances, devices, or systems where malfunction of these products can reasonably be expected to result in personal injury. Philips customers using or selling these products for use in such applications do so at their own risk and agree to fully indemnify Philips for any damages resulting from such improper use or sale.

PURCHASE OF PHILIPS I²C COMPONENTS

Purchase of Philips I²C components conveys a license under the Philips' I²C patent to use the components in the I²C system provided the system conforms to the I²C specification defined by Philips. This specification can be ordered using the code 9398 393 40011.

Video processor with automatic cut-off control

TDA4686

NOTES

Video processor with automatic cut-off control

TDA4686

NOTES

Video processor with automatic cut-off control

TDA4686

NOTES

Philips Semiconductors – a worldwide company

Argentina: see South America

Australia: 34 Waterloo Road, NORTH RYDE, NSW 2113,
Tel. +61 2 9805 4455, Fax. +61 2 9805 4466

Austria: Computerstr. 6, A-1101 WIEN, P.O. Box 213,
Tel. +43 1 60 101, Fax. +43 1 60 101 1210

Belarus: Hotel Minsk Business Center, Bld. 3, r. 1211, Volodarski Str. 6,
220050 MINSK, Tel. +375 172 200 733, Fax. +375 172 200 773

Belgium: see The Netherlands

Brazil: see South America

Bulgaria: Philips Bulgaria Ltd., Energoproject, 15th floor,
51 James Bourchier Blvd., 1407 SOFIA,
Tel. +359 2 689 211, Fax. +359 2 689 102

Canada: PHILIPS SEMICONDUCTORS/COMPONENTS,
Tel. +1 800 234 7381

China/Hong Kong: 501 Hong Kong Industrial Technology Centre,
72 Tat Chee Avenue, Kowloon Tong, HONG KONG,
Tel. +852 2319 7888, Fax. +852 2319 7700

Colombia: see South America

Czech Republic: see Austria

Denmark: Prags Boulevard 80, PB 1919, DK-2300 COPENHAGEN S,
Tel. +45 32 88 2636, Fax. +45 31 57 0044

Finland: Sinikalliontie 3, FIN-02630 ESPOO,
Tel. +358 9 615800, Fax. +358 9 61580920

France: 4 Rue du Port-aux-Vins, BP317, 92156 SURESNES Cedex,
Tel. +33 1 40 99 6161, Fax. +33 1 40 99 6427

Germany: Hammerbrookstraße 69, D-20097 HAMBURG,
Tel. +49 40 23 53 60, Fax. +49 40 23 536 300

Greece: No. 15, 25th March Street, GR 17778 TAVROS/ATHENS,
Tel. +30 1 4894 339/239, Fax. +30 1 4814 240

Hungary: see Austria

India: Philips INDIA Ltd, Shivsagar Estate, A Block, Dr. Annie Besant Rd.
Worli, MUMBAI 400 018, Tel. +91 22 4938 541, Fax. +91 22 4938 722

Indonesia: see Singapore

Ireland: Newstead, Clonskeagh, DUBLIN 14,
Tel. +353 1 7640 000, Fax. +353 1 7640 200

Israel: RAPAC Electronics, 7 Kehilat Saloniki St, PO Box 18053,
TEL AVIV 61180, Tel. +972 3 645 0444, Fax. +972 3 649 1007

Italy: PHILIPS SEMICONDUCTORS, Piazza IV Novembre 3,
20124 MILANO, Tel. +39 2 6752 2531, Fax. +39 2 6752 2557

Japan: Philips Bldg 13-37, Kohnan 2-chome, Minato-ku, TOKYO 108,
Tel. +81 3 3740 5130, Fax. +81 3 3740 5077

Korea: Philips House, 260-199 Itaewon-dong, Yongsan-ku, SEOUL,
Tel. +82 2 709 1412, Fax. +82 2 709 1415

Malaysia: No. 76 Jalan Universiti, 46200 PETALING JAYA, SELANGOR,
Tel. +60 3 750 5214, Fax. +60 3 757 4880

Mexico: 5900 Gateway East, Suite 200, EL PASO, TEXAS 79905,
Tel. +9-5 800 234 7381

Middle East: see Italy

Netherlands: Postbus 90050, 5600 PB EINDHOVEN, Bldg. VB,
Tel. +31 40 27 82785, Fax. +31 40 27 88399

New Zealand: 2 Wagener Place, C.P.O. Box 1041, AUCKLAND,
Tel. +64 9 849 4160, Fax. +64 9 849 7811

Norway: Box 1, Manglerud 0612, OSLO,
Tel. +47 22 74 8000, Fax. +47 22 74 8341

Philippines: Philips Semiconductors Philippines Inc.,
106 Valero St. Salcedo Village, P.O. Box 2108 MCC, MAKATI,
Metro MANILA, Tel. +63 2 816 6380, Fax. +63 2 817 3474

Poland: Ul. Lukiska 10, PL 04-123 WARSZAWA,
Tel. +48 22 612 2831, Fax. +48 22 612 2327

Portugal: see Spain

Romania: see Italy

Russia: Philips Russia, Ul. Usatcheva 35A, 119048 MOSCOW,
Tel. +7 095 755 6918, Fax. +7 095 755 6919

Singapore: Lorong 1, Toa Payoh, SINGAPORE 1231,
Tel. +65 350 2538, Fax. +65 251 6500

Slovakia: see Austria

Slovenia: see Italy

South Africa: S.A. PHILIPS Pty Ltd., 195-215 Main Road Martindale,
2092 JOHANNESBURG, P.O. Box 7430 Johannesburg 2000,
Tel. +27 11 470 5911, Fax. +27 11 470 5494

South America: Rua do Rocio 220, 5th floor, Suite 51,
04552-903 São Paulo, SÃO PAULO - SP, Brazil,
Tel. +55 11 821 2333, Fax. +55 11 829 1849

Spain: Balmes 22, 08007 BARCELONA,
Tel. +34 3 301 6312, Fax. +34 3 301 4107

Sweden: Kottbygatan 7, Akalla, S-16485 STOCKHOLM,
Tel. +46 8 632 2000, Fax. +46 8 632 2745

Switzerland: Allmendstrasse 140, CH-8027 ZÜRICH,
Tel. +41 1 488 2686, Fax. +41 1 481 7730

Taiwan: Philips Semiconductors, 6F, No. 96, Chien Kuo N. Rd., Sec. 1,
TAIPEI, Taiwan Tel. +886 2 2134 2865, Fax. +886 2 2134 2874

Thailand: PHILIPS ELECTRONICS (THAILAND) Ltd.,
209/2 Sanpavuth-Bangna Road Prakanong, BANGKOK 10260,
Tel. +66 2 745 4090, Fax. +66 2 398 0793

Turkey: Talatpasa Cad. No. 5, 80640 GÜLTEPE/ISTANBUL,
Tel. +90 212 279 2770, Fax. +90 212 282 6707

Ukraine: PHILIPS UKRAINE, 4 Patrice Lumumba str., Building B, Floor 7,
252042 KIEV, Tel. +380 44 264 2776, Fax. +380 44 268 0461

United Kingdom: Philips Semiconductors Ltd., 276 Bath Road, Hayes,
MIDDLESEX UB3 5BX, Tel. +44 181 730 5000, Fax. +44 181 754 8421

United States: 811 East Arques Avenue, SUNNYVALE, CA 94088-3409,
Tel. +1 800 234 7381

Uruguay: see South America

Vietnam: see Singapore

Yugoslavia: PHILIPS, Trg N. Pasica 5/v, 11000 BEOGRAD,
Tel. +381 11 625 344, Fax. +381 11 635 777

For all other countries apply to: Philips Semiconductors, Marketing & Sales Communications,
Building BE-p, P.O. Box 218, 5600 MD EINDHOVEN, The Netherlands, Fax. +31 40 27 24825

Internet: <http://www.semiconductors.philips.com>

© Philips Electronics N.V. 1997

SCA54

All rights are reserved. Reproduction in whole or in part is prohibited without the prior written consent of the copyright owner.

The information presented in this document does not form part of any quotation or contract, is believed to be accurate and reliable and may be changed without notice. No liability will be accepted by the publisher for any consequence of its use. Publication thereof does not convey nor imply any license under patent- or other industrial or intellectual property rights.

Printed in The Netherlands

547047/25/03/pp28

Date of release: 1997 Jun 23

Document order number: 9397 750 02046

Let's make things better.

**Philips
Semiconductors**



PHILIPS