

SI-3000KF Series Low Current Consumption, Low Dropout Voltage

Features

- Compact full-mold package (equivalent to TO220)
- Output current: 1.0A
- Low dropout voltage: $V_{DIF} \leq 0.5V$ (at $I_o = 1.0A$)
- High ripple rejection: 75dB
- Low circuit current at output OFF: I_q (OFF) $\leq 1\mu A$
- Built-in overcurrent and thermal protection circuits

Applications

- Secondary stabilized power supply (local power supply)

Recommended Operating Conditions

Parameter	Symbol	Ratings		Unit
		SI-3010KF		
Input Voltage Range	V_{IN}	2.4 ² to 27 ¹		V
Output Current Range	I_o	0 to 1.0 ¹		A
Output Voltage Variable Range	$V_{O}ADJ$	1.1 to 16		V
Operating Ambient Temperature	T_{op}	-30 to +85		°C
Operating Junction Temperature	T_j	-20 to +100		°C

*1: V_{IN} (max) and I_o (max) are restricted by the relationship P_D (max) = $(V_{IN} - V_o) \times I_o = 16.6W$.

*2: Refer to the Dropout Voltage parameter.

Electrical Characteristics

Parameter	Symbol	Ratings			Unit	
		SI-3010KF				
		min.	typ.	max.		
Reference Voltage	V_{ADJ}	0.98	1.00	1.02	V	
	Conditions	$V_{IN}=7V, I_o=0.01A, V_C=2V, V_o=5A$				
Line Regulation	ΔV_{OLINE}			30	mV	
	Conditions	$V_{IN}=6$ to $15V, I_o=0.01A, V_C=2V, V_o=5A$				
Load Regulation	ΔV_{OLOAD}			75	mV	
	Conditions	$V_{IN}=7V, I_o=0$ to $1A, V_C=2V, V_o=5A$				
Dropout Voltage	V_{DIF}			0.3	V	
	Conditions	$I_o=0.5A, V_C=2V, V_o=5V$				
	Conditions	$I_o=1.0A, V_C=2V, V_o=5V$				
Quiescent Circuit Current	I_q			600	μA	
	Conditions	$V_{IN}=7V, I_o=0A, V_C=2V$				
Circuit Current at Output OFF	I_q (OFF)			1	μA	
	Conditions	$V_{IN}=7V, V_C=0V$				
Temperature Coefficient of Output Voltage	$\Delta V_o/\Delta T_a$		± 0.5		mV/°C	
	Conditions	$V_{IN}=7V, I_o=0.01A, V_C=2V, T_j=0$ to $100^\circ C, V_o=2.5V$				
Ripple Rejection	R_{REJ}		75		dB	
	Conditions	$V_{IN}=7V, I_o=0.1A, V_C=2V, f=100$ to $120Hz, V_o=5V$				
Overcurrent Protection Starting Current ³	I_{S1}	1.1			A	
	Conditions	$V_{IN}=7V, V_C=2V$				
V _C Terminal	Control Voltage (Output ON) ⁴	V_C, I_H	2		V	
		Conditions	$V_{IN}=7V$			
	Control Voltage (Output OFF)	V_C, I_L			0.8	V
		Conditions	$V_{IN}=7V$			
	Control Current (Output ON)	I_C, I_H			40	μA
		Conditions	$V_{IN}=7V, V_C=2V$			
Control Current (Output OFF)	I_C, I_L	-5	0		μA	
	Conditions	$V_{IN}=7V, V_C=0V$				
Input Overvoltage Shutdown Voltage	V_{OVP}	33			V	
	Conditions	$I_o=0.01A$				

*3: I_{S1} is specified at the 5% drop point of output voltage V_o on the condition that V_{IN} = overcurrent protection starting current, $I_o = 10$ mA.

*4: Output is OFF when the output control terminal V_C is open. Each input level is equivalent to LS-TTL level. Therefore, the device can be driven directly by LS-TTLs.

*5: SI-3000KFE cannot be used in the following applications because the built-in foldback-type overcurrent protection may cause errors during start-up stage.

(1) Constant current load (2) Positive and negative power supply (3) Series-connected power supply (4) V_o adjustment by raising ground voltage

Absolute Maximum Ratings

($T_a=25^\circ C$)

Parameter	Symbol	Ratings		Unit	Remarks
		SI-3010KF			
DC Input Voltage	V_{IN}	35 ¹		V	
Output Control Terminal Voltage	V_C	V_{IN}		V	
DC Output Current	I_o	1.0		A	
Power Dissipation	P_{D1}	16.6		W	With infinite heatsink
	P_{D2}	1.72		W	Without heatsink, stand-alone operation
Junction Temperature	T_j	-40 to +125		°C	
Storage Temperature	T_{stg}	-40 to +125		°C	
Operating Ambient Temperature	T_{op}	-40 to +100		°C	
Thermal Resistance (Junction to Case)	θ_{j-c}	6.0		°C/W	
Thermal Resistance (Junction to Ambient Air)	θ_{j-a}	58		°C/W	Without heatsink, stand-alone operation

*1: A built-in input-overvoltage-protection circuit shuts down the output voltage at the Input Overvoltage Shutdown Voltage of the electrical characteristics.

■Block Diagram

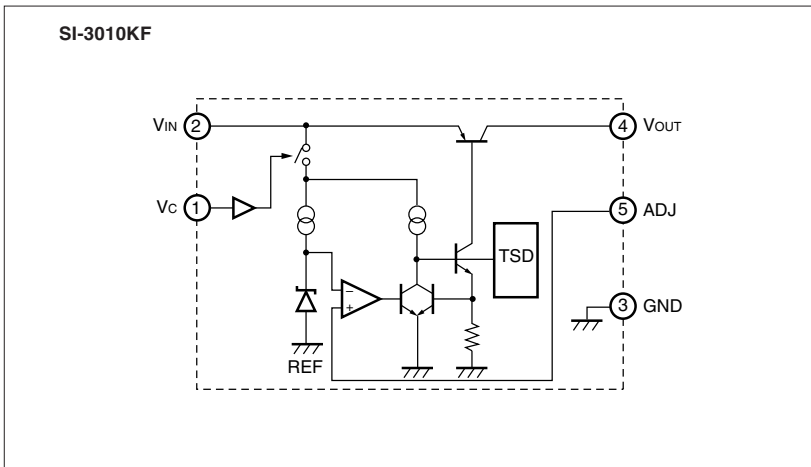

■Ta-Pd Characteristics

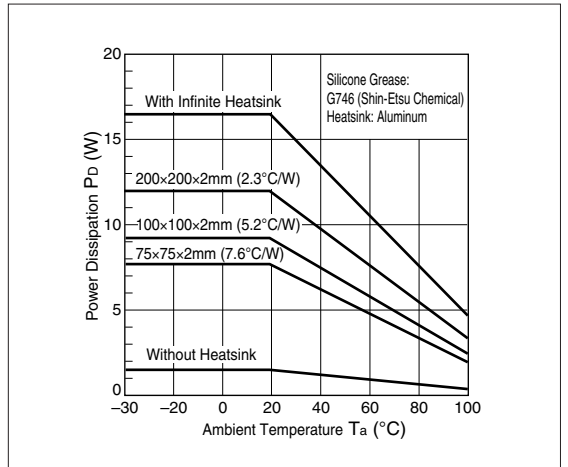

■Typical Connection Diagram

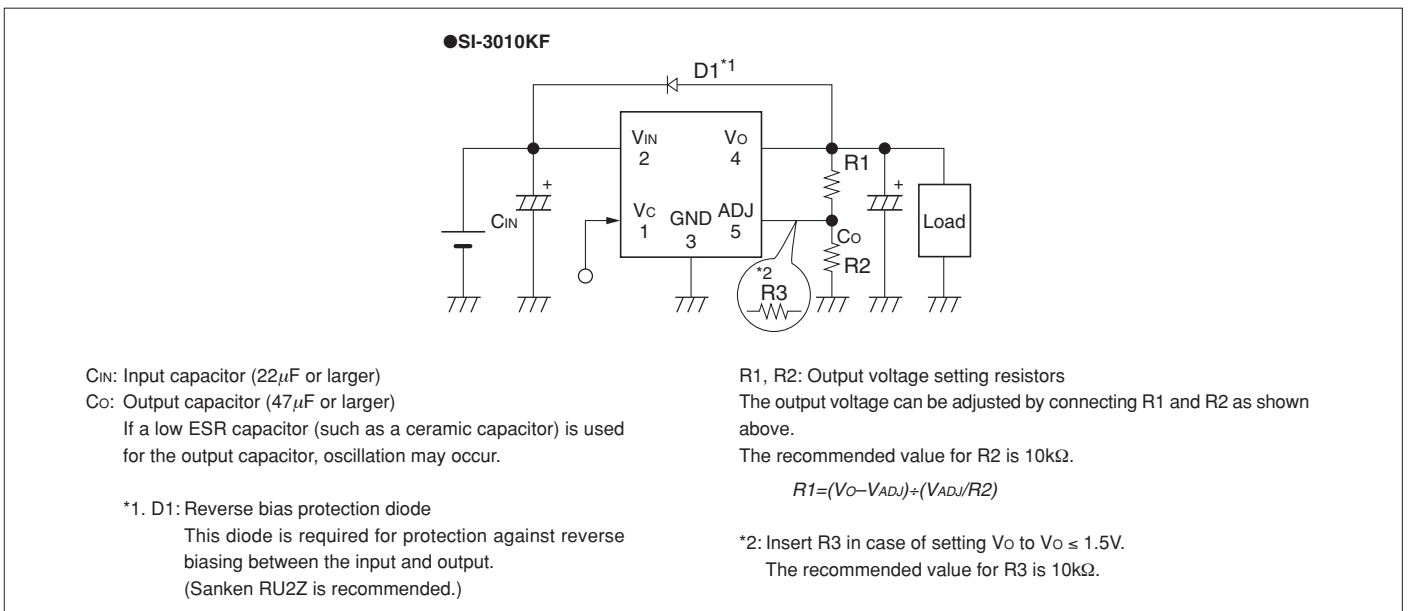

■External Dimensions (TO220F-5)

(Unit : mm)

