

HT82M75R/HT82M75RE/HT82M75REW HT82K75R/HT82K75RE/HT82K75REW 2.4GHz Transceiver 8-Bit OTP MCU

Features

- Operating voltage:
 $f_{SYS}=6\text{MHz}$: 1.8V~3.3V
- Internal 6MHz RC oscillator for f_{SYS}
- Power down and wake-up functions to reduce power consumption
- Two bit to define microcontroller system clock ($f_{SYS}/1$, $f_{SYS}/2$, $f_{SYS}/4$)
- All instructions executed in one or two machine cycles
- Table read instructions
- 63 powerful instructions
- 6-level subroutine nesting
- Bit manipulation instruction
- Program Memory: 4K×15
- Data Memory: 128×8~160×8
- Watchdog Timer function
- Up to 40 bidirectional I/O lines with pull-high options
- All I/O pins have falling and rising edge wake-up function
- Single 16-bit internal timer with overflow interrupt and timer input
- SPI interface shared with I/O lines
- Low voltage reset function (LVR) for DC_DC output controlled by configuration option
- Built-in DC/DC to provide stable 2.8V, 3.0V, 3.3V with error $\pm 5\%$ selected by configuration options
- Low voltage detector (LVD) with levels 1.8V/2.0V/2.2V/2.5V/2.8V $\pm 5\%$ for battery input (BAT_IN) selected by application program
- Wide range of available package types
- Optional Peripheral -- EEPROM Memory with 128×8 capacity
- Optional Peripheral -- RF Transceiver with 2.4GHz RF frequency

General Description

The device is an 8-bit high performance, RISC architecture microcontroller devices specifically designed for multiple I/O, mouse/keyboard appliances and SPI control product applications. The advantages of low power consumption, I/O flexibility, Timer functions, Watchdog

timer, Power Down, wake-up functions together with the optional peripherals such as EEPROM Memory and RF transceiver provide the devices with versatility for industrial control, consumer products, subsystem controllers, RF module control, etc.

Selection Table

| Part No. | Program Memory | Data Memory | Data EEPROM | I/O | Timer | DC/DC Converter | SPI Interface | RF Transceiver | Built-in OSC | Stack | Package |
|---------------------------|----------------|-------------|-------------|-----|----------|-----------------|---------------|----------------|--------------|-------|------------------------|
| HT82M75R | 4K×15 | 128×8 | — | 24 | 16-bit×1 | √ | √ | — | √ | 6 | 20/28SOP/SSOP 32QFN |
| HT82K75R | 4K×15 | 160×8 | — | 40 | 16-bit×1 | √ | √ | — | √ | 6 | 48SSOP |
| HT82M75RE ⁽¹⁾ | 4K×15 | 128×8 | 128×8 | 22 | 16-bit×1 | √ | √ | — | √ | 6 | 32QFN |
| HT82K75RE ⁽¹⁾ | 4K×15 | 160×8 | 128×8 | 38 | 16-bit×1 | √ | √ | — | √ | 6 | 48SSOP |
| HT82M75REW ⁽²⁾ | 4K×15 | 128×8 | 128×8 | 15 | 16-bit×1 | √ | √ | √ | √ | 6 | 40QFN (6×6×0.85mm) |
| HT82K75REW ⁽²⁾ | 4K×15 | 160×8 | 128×8 | 31 | 16-bit×1 | √ | √ | √ | √ | 6 | 64LQFP |

Note: (1) There is an additional peripheral known as the Data EEPROM with capacity of 128 bytes in HT82M75RE and HT82K75RE devices. All information related to the Data EEPROM will be described in the following EEPROM Data Memory section.

(2) There are additional peripherals named RF Transceiver with RF frequency of 2.4GHz and Data EEPROM with capacity of 128 bytes in HT82M75REW and HT82K75REW devices. All information related to the RF Transceiver and EEPROM Data Memory will be described in the corresponding section respectively.

(3) As devices exist in more than one package format, the table reflects the situation for the package with the most pins.

Block Diagram

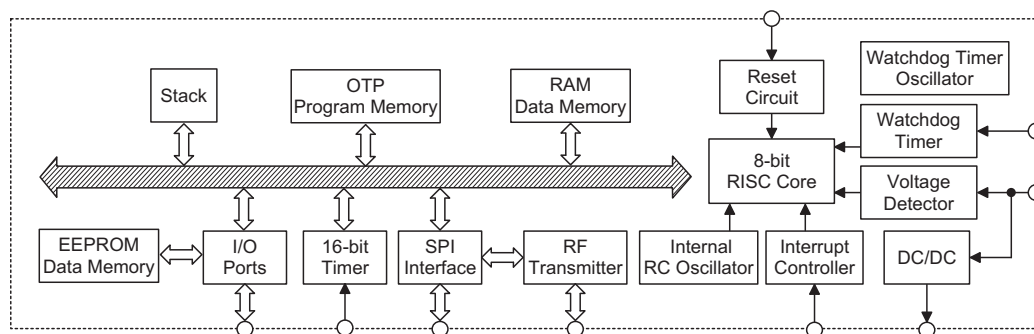

Pin Assignment

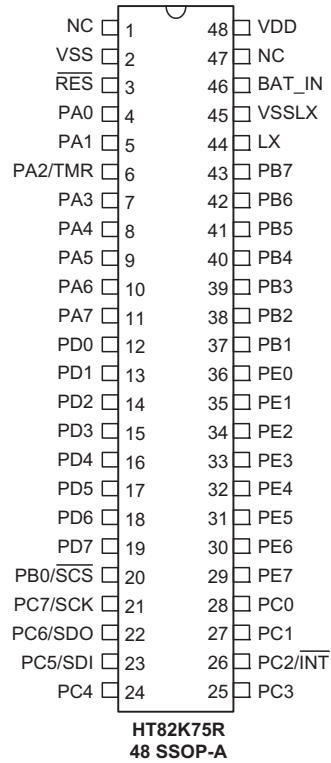
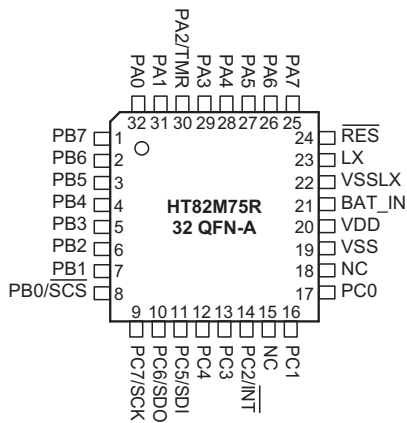
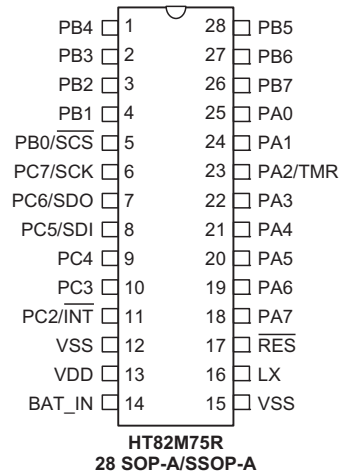
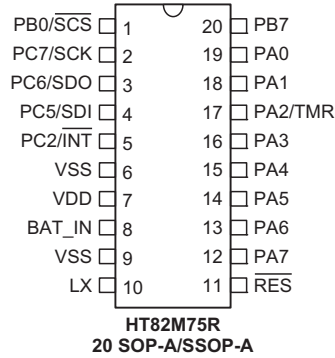

Pin Description

The following table only includes the pins which are directly related to the MCU. The pin descriptions of the additional peripheral functions are located at the corresponding section of the datasheet along with the relevant peripheral function functional description.

| Pin Name | I/O | Options | Description |
|--|-----|--------------------------------------|--|
| PA0~PA1 PA2/TMR PA3~PA7 | I/O | Pull-high Wake-up | Bidirectional 8-bit input/output port. Each pin can be configured as a wake-up input (both falling and rising edge) by a configuration option. Software instructions determine if the pin is a CMOS output or Schmitt Trigger input. Configuration options determine if the pins have pull-high resistors. PA2 is shared with the external timer input pin TMR. |
| PB0/ \overline{SCS} PB1~PB7 | I/O | Pull-high or Wake-up CMOS/NMOS | Bidirectional 8-bit input/output port. Each pin can be configured as a wake-up input (both falling and rising edge) by a configuration option. Software instructions determine if the pin is a CMOS output or Schmitt Trigger input. Configuration options determine if the pins have pull-high resistors. Also a configuration option determines if the PB0 is a CMOS output type or NMOS output type. PB0 is shared with \overline{SCS} of the SPI interface. |
| PC0~PC1 PC2/ \overline{INT} PC3~PC4 PC5/SDI PC6/SDO PC7/SCK | I/O | Pull-high or Wake-up CMOS/NMOS | Bidirectional 8-bit input/output port. Each pin can be configured as a wake-up input (both falling and rising edge) by a configuration option. Software instructions determine if the pin is a CMOS output or Schmitt Trigger input. Configuration options determine if the pins have pull-high resistors. Also a configuration option determines if the PC pins are CMOS output type or NMOS output type. The \overline{INT} is shared with PC2, PC5~PC7 are shared with the SPI interface. |
| PD0~PD7 (HT82K75R only) | I/O | Pull-high or Wake-up | Bidirectional 8-bit input/output port. Each nibble can be configured as wake-up inputs (both falling and rising edge) by a configuration option. Software instructions determine if the pin is a CMOS output or Schmitt Trigger input. Configuration options determine if the pins have pull-high resistors. |
| PE0~PE7 (HT82K75R only) | I/O | Pull-high or Wake-up | Bidirectional 8-bit input/output port. Each nibble can be configured as wake-up inputs (both falling and rising edge) by a configuration option. Software instructions determine if the pin is a CMOS output or Schmitt Trigger input. Configuration options determine if the pins have pull-high resistors. |
| VSS | — | — | Negative power supply, ground |
| \overline{RES} | I | — | Schmitt Trigger reset input. Active low |
| VDD | — | — | Positive power supply |
| BAT_IN | I | — | Battery input |
| LX | I | — | DC/DC LX switch |
| VSSLX | I | — | DC/DC ground |

Absolute Maximum Ratings

| | | | |
|-------------------------------|--------------------------------|-----------------------------|----------------------------------|
| Supply Voltage | $V_{SS}-0.3V$ to $V_{SS}+6.0V$ | Storage Temperature | $-50^{\circ}C$ to $125^{\circ}C$ |
| Input Voltage | $V_{SS}-0.3V$ to $V_{DD}+0.3V$ | Operating Temperature | $-40^{\circ}C$ to $85^{\circ}C$ |
| I_{OL} Total | 150mA | I_{OH} Total | -100mA |
| Total Power Dissipation | 500mW | | |

Note: These are stress ratings only. Stresses exceeding the range specified under "Absolute Maximum Ratings" may cause substantial damage to the device. Functional operation of this device at other conditions beyond those listed in the specification is not implied and prolonged exposure to extreme conditions may affect device reliability.

D.C. Characteristics

Ta=25°C

| Symbol | Parameter | Test Conditions | | Min. | Typ. | Max. | Unit |
|------------------|---|-----------------|--|--------------------|------|--------------------|------|
| | | V _{DD} | Conditions | | | | |
| V _{BAT} | BAT_IN Operating Voltage | — | — | 1.8 | 2.2 | 3.3 | V |
| I _{DD} | Operating Current (Crystal OSC) | 3V | No load, f _{SYS} = 6MHz | — | 3 | 6 | mA |
| I _{STB} | Standby Current | — | No load, system HALT WDT disable, LVR disable | — | — | 20 | μA |
| V _{IL1} | Input Low Voltage for I/O (Schmitt Trigger) | — | — | 0 | — | 0.3V _{DD} | V |
| V _{IH1} | Input High Voltage for I/O (Schmitt Trigger) | — | — | 0.7V _{DD} | — | V _{DD} | V |
| V _{IL2} | Input Low Voltage ($\overline{\text{RES}}$) | — | — | 0 | — | 0.3V _{DD} | V |
| V _{IH2} | Input High Voltage ($\overline{\text{RES}}$) | — | — | 0.9V _{DD} | — | V _{DD} | V |
| I _{OL1} | Other I/O Pins Sink Current | 3V | V _{OL} =0.1V _{DD} | 4 | — | — | mA |
| I _{OH1} | Other I/O Pins Source Current | 3V | V _{OH} =0.9V _{DD} | -2.5 | -4.5 | — | mA |
| R _{PH1} | Other Pins Internal Pull-high Resistance | 3V | — | 10 | 30 | 50 | kΩ |

A.C. Characteristics

Ta=25°C

| Symbol | Parameter | Test Conditions | | Min. | Typ. | Max. | Unit |
|------------------------|--|-----------------|------------|------|------|------|--------------------|
| | | V _{DD} | Conditions | | | | |
| f _{SYS} | System Clock | 3V | — | 5.7 | 6 | 6.3 | MHz |
| t _{RCSYS} | Watchdog OSC Period | 3V | — | — | 71 | — | μs |
| t _{WDT1} | Watchdog Time-out Period with 6-stage Prescaler | 3V | WDTS=1 | — | 4.57 | — | ms |
| t _{RES} | External Reset Low Pulse Width | — | — | 1 | — | — | ms |
| t _{SST} | System Start-up Timer | — | — | — | 512 | — | 1/f _{SYS} |
| t _{LVR} | Low Voltage Width to Reset | — | — | 0.25 | 1 | 2 | ms |
| t _{Wake-up} | MCU Wake-up Timer | — | — | — | — | 1 | ms |
| t _{configure} | Watchdog Time-out Period | — | — | — | 1024 | — | t _{RCSYS} |

Power-On Reset Characteristics

Ta=25°C

| Symbol | Parameter | Test Conditions | | Min. | Typ. | Max. | Unit |
|-------------------|--|-----------------|---|------|------|------|------|
| | | V _{DD} | Conditions | | | | |
| I _{POR} | Operating current | 1.8V~3.3V | — | — | 1.0 | — | μA |
| RR _{VDD} | V _{DD} Rise Rate to Ensure Power-on Reset | — | Without 0.1μF between V _{DD} and V _{SS} | 0.05 | — | — | V/ms |
| V _{POR} | Maximum V _{DD} Start Voltage to Ensure Power-on Reset | — | Without 0.1μF between V _{DD} and V _{SS} , Ta=25°C | 0.9 | — | 1.5 | V |
| t _{POR} | Power-on Reset Low Pulse Width | — | Without 0.1μF between V _{DD} and V _{SS} | 2 | — | — | μs |
| | | | With 0.1μF between V _{DD} and V _{SS} | 10 | — | — | μs |

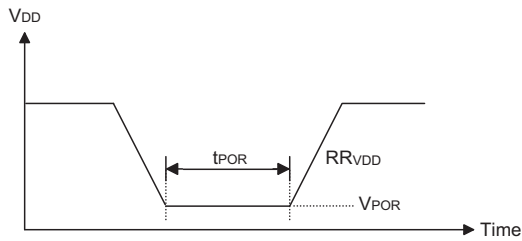

System Architecture

A key factor in the high-performance features of the Holtek range of microcontrollers is attributed to the internal system architecture. The devices take advantage of the usual features found within RISC microcontrollers providing increased speed of operation and enhanced performance. The pipelining scheme is implemented in such a way that instruction fetching and instruction execution are overlapped, hence instructions are effectively executed in one cycle, with the exception of branch or call instructions. An 8-bit wide ALU is used in practically all operations of the instruction set. It carries out arithmetic operations, logic operations, rotation, increment, decrement, branch decisions, etc. The internal data path is simplified by moving data through the Accumulator and the ALU. Certain internal registers are implemented in the Data Memory and can be directly or indirectly addressed. The simple addressing methods of these registers along with additional architectural features ensure that a minimum of external components is required to provide a functional I/O control system with maximum reliability and flexibility.

Clocking and Pipelining

The main system clock, derived from either a Crystal/Resonator or RC oscillator is subdivided into four internally generated non-overlapping clocks, T1~T4. The Program Counter is incremented at the beginning of the T1 clock during which time a new instruction is fetched. The remaining T2~T4 clocks carry out the decoding and

execution functions. In this way, one T1~T4 clock cycle forms one instruction cycle. Although the fetching and execution of instructions takes place in consecutive instruction cycles, the pipelining structure of the microcontroller ensures that instructions are effectively executed in one instruction cycle. The exception to this are instructions where the contents of the Program Counter are changed, such as subroutine calls or jumps, in which case the instruction will take one more instruction cycle to execute.

For instructions involving branches, such as jump or call instructions, two machine cycles are required to complete instruction execution. An extra cycle is required as the program takes one cycle to first obtain the actual jump or call address and then another cycle to actually execute the branch. The requirement for this extra cycle should be taken into account by programmers in timing sensitive applications

Program Counter

During program execution, the Program Counter is used to keep track of the address of the next instruction to be executed. It is automatically incremented by one each time an instruction is executed except for instructions, such as "JMP" or "CALL" that demand a jump to a non-consecutive Program Memory address. It must be noted that only the lower 8 bits, known as the Program Counter Low Register, are directly addressable by user.

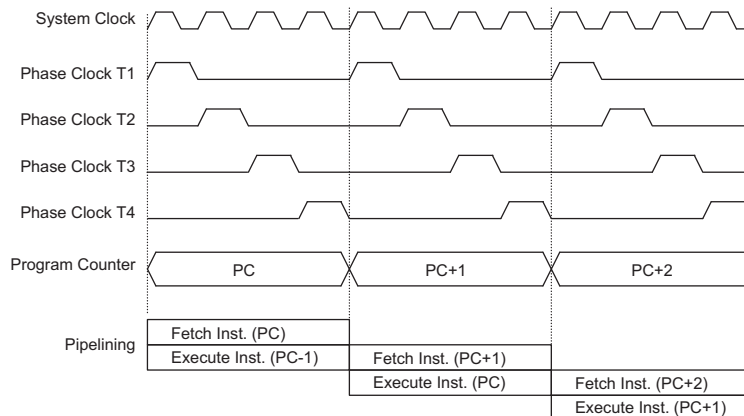

System Clocking and Pipelining

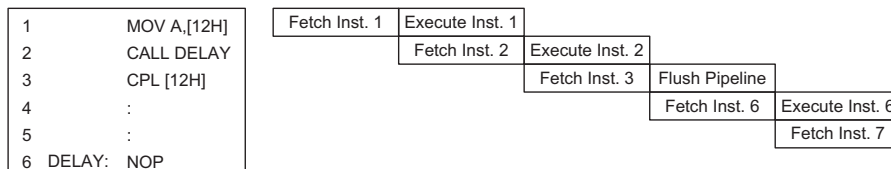

Instruction Fetching

When executing instructions requiring jumps to non-consecutive addresses such as a jump instruction, a subroutine call, interrupt or reset, etc., the microcontroller manages program control by loading the required address into the Program Counter. For conditional skip instructions, once the condition has been met, the next instruction, which has already been fetched during the present instruction execution, is discarded and a dummy cycle takes its place while the correct instruction is obtained.

The lower byte of the Program Counter, known as the Program Counter Low register or PCL, is available for program control and is a readable and writeable register. By transferring data directly into this register, a short program jump can be executed directly, however, as only this low byte is available for manipulation, the jumps are limited to the present page of memory, that is 256 locations. When such program jumps are executed it should also be noted that a dummy cycle will be inserted.

The lower byte of the Program Counter is fully accessible under program control. Manipulating the PCL might cause program branching, so an extra cycle is needed to pre-fetch. Further information on the PCL register can be found in the Special Function Register section.

Stack

This is a special part of the memory which is used to save the contents of the Program Counter only. The stack has 6 levels and is neither part of the data nor part of the program space, and is neither readable nor

writeable. The activated level is indexed by the Stack Pointer, SP, and is neither readable nor writeable. At a subroutine call or interrupt acknowledge signal, the contents of the Program Counter are pushed onto the stack. At the end of a subroutine or an interrupt routine, signaled by a return instruction, RET or RETI, the Program Counter is restored to its previous value from the stack. After a device reset, the Stack Pointer will point to the top of the stack.

If the stack is full and an enabled interrupt takes place, the interrupt request flag will be recorded but the acknowledge signal will be inhibited. When the Stack Pointer is decremented, by RET or RETI, the interrupt will be serviced. This feature prevents stack overflow allowing the programmer to use the structure more easily. However, when the stack is full, a CALL subroutine instruction can still be executed which will result in a stack overflow. Precautions should be taken to avoid such cases which might cause unpredictable program branching.

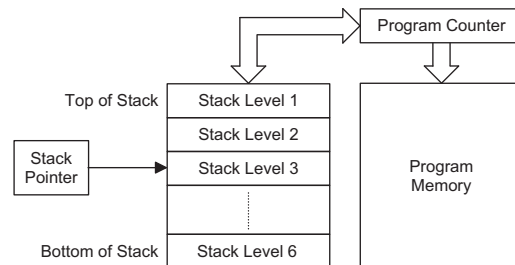

| Mode | Program Counter Bits | | | | | | | | | | | |
|------------------------------|----------------------|------|-----|-----|----|----|----|----|----|----|----|----|
| | b11 | b10 | b9 | b8 | b7 | b6 | b5 | b4 | b3 | b2 | b1 | b0 |
| Initial Reset | 0 | 0 | 0 | 0 | 0 | 0 | 0 | 0 | 0 | 0 | 0 | 0 |
| SPI Interrupt | 0 | 0 | 0 | 0 | 0 | 0 | 0 | 0 | 0 | 1 | 0 | 0 |
| Timer/Event Counter Overflow | 0 | 0 | 0 | 0 | 0 | 0 | 0 | 0 | 1 | 0 | 0 | 0 |
| External interrupt | 0 | 0 | 0 | 0 | 0 | 0 | 0 | 0 | 1 | 1 | 0 | 0 |
| Skip | Program Counter + 2 | | | | | | | | | | | |
| Loading PCL | PC11 | PC10 | PC9 | PC8 | @7 | @6 | @5 | @4 | @3 | @2 | @1 | @0 |
| Jump, Call Branch | #11 | #10 | #9 | #8 | #7 | #6 | #5 | #4 | #3 | #2 | #1 | #0 |
| Return from Subroutine | S11 | S10 | S9 | S8 | S7 | S6 | S5 | S4 | S3 | S2 | S1 | S0 |

Program Counter

Note: PC11~PC8: Current Program Counter bits
#11~#0: Instruction code address bits

@7~@0: PCL bits
S11~S0: Stack register bits

Arithmetic and Logic Unit – ALU

The arithmetic-logic unit or ALU is a critical area of the microcontroller that carries out arithmetic and logic operations of the instruction set. Connected to the main microcontroller data bus, the ALU receives related instruction codes and performs the required arithmetic or logical operations after which the result will be placed in the specified register. As these ALU calculation or operations may result in carry, borrow or other status changes, the status register will be correspondingly updated to reflect these changes. The ALU supports the following functions:

- Arithmetic operations: ADD, ADDM, ADC, ADCM, SUB, SUBM, SBC, SBCM, DAA
- Logic operations: AND, OR, XOR, ANDM, ORM, XORM, CPL, CPLA
- Rotation RRA, RR, RRCA, RRC, RLA, RL, RLCA, RLC
- Increment and Decrement INCA, INC, DECA, DEC
- Branch decision, JMP, SZ, SZA, SNZ, SIZ, SDZ, SIZA, SDZA, CALL, RET, RETI

Program Memory

The Program Memory is the location where the user code or program is stored. The device is supplied with One-Time Programmable, OTP, memory where users can program their application code into the device. By using the appropriate programming tools, OTP devices

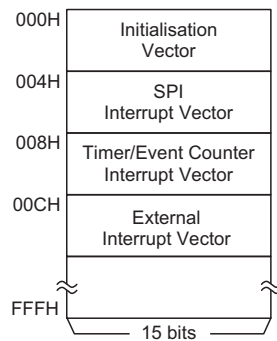

Program Memory Structure

offer users the flexibility to freely develop their applications which may be useful during debug or for products requiring frequent upgrades or program changes. OTP devices are also applicable for use in applications that require low or medium volume production runs.

Structure

The Program Memory has a capacity of 4K×15 bits. The Program Memory is addressed by the Program Counter and also contains data, table information and interrupt entries. Table data, which can be setup in any location within the Program Memory, is addressed by separate table pointer registers.

Special Vectors

Within the Program Memory, certain locations are reserved for special usage such as reset and interrupts.

- Location 000H
This vector is reserved for use by the device reset for program initialisation. After a device reset is initiated, the program will jump to this location and begin execution.
- Location 004H
This vector is used by serial interface. When 8-bits of data have been received or transmitted successfully from serial interface. The program will jump to this location and begin execution if the interrupt is enable and the stack is not full.
- Location 008H
This vector is used by the timer/event counter. If a counter overflow occurs, the program will jump to this location and begin execution if the timer interrupt is enabled and the stack is not full.
- Location 00CH
This vector is used by the external interrupt. If the \overline{INT} external input pin on the device receives a high to low transition, the program will jump to this location and begin execution, if the interrupt is enabled and the stack is not full.
- Table location
Any location in the program memory can be used as look-up tables. There are three method to read the ROM data by two table read instructions: "TABRDC" and "TABRDL", transfer the contents of the lower-order byte to the specified data memory, and the higher-order byte to TBLH (08H).

| Instruction | Table Location Bits | | | | | | | | | | | |
|-------------|---------------------|------|-----|-----|----|----|----|----|----|----|----|----|
| | b11 | b10 | b9 | b8 | b7 | b6 | b5 | b4 | b3 | b2 | b1 | b0 |
| TABRDC[m] | PC11 | PC10 | PC9 | PC8 | @7 | @6 | @5 | @4 | @3 | @2 | @1 | @0 |
| TABRDL[m] | 1 | 1 | 1 | 1 | @7 | @6 | @5 | @4 | @3 | @2 | @1 | @0 |

Table Location

Note: PC11~PC8: Current program counter bits when TBHP is disabled
TBHP register bit3~bit0 when TBHP is enabled
@7~@0: Table Pointer TBLP bits

- ◆ The three methods are shown as follows: The instructions "TABRDC [m]" (the current page, one page=256words), where the table location is defined by TBLP (07H) in the current page. And the configuration option TBHP is disabled (default).
- ◆ The instructions "TABRDC [m]", where the table location is defined by registers TBLP (07H) and TBHP (01FH). And the configuration option TBHP is enabled.
- ◆ The instructions "TABRDL [m]", where the table location is defined by register TBLP (07H) in the last page (F00H~FFFH).

Only the destination of the lower-order byte in the table is well-defined, the other bits of the table word are transferred to the lower portion of TBLH, and the remaining 1-bit words are read as "0". The Table Higher-order byte register (TBLH) is read only. The table pointer (TBLP, TBHP) is a read/write register (07H, 1FH), which indicates the table location. Before accessing the table, the location must be placed in the TBLP and TBHP (If the configuration option TBHP is disabled, the value in TBHP has no effect). The TBLH is read only and cannot be restored. If the main routine and the ISR (Interrupt Service Routine) both employ the table read instruction, the contents of the TBLH in the main routine are likely to be changed by the table read instruction used in the ISR. Errors can occur. In other words, using the table read instruction in the main routine and the ISR simultaneously should be avoided. However, if the table read instruction has to be applied in both the main routine and the ISR, the interrupt should be disabled prior to the table read instruction. It

will not be enabled until the TBLH has been backed up. All table related instructions require two cycles to complete the operation. These areas may function as normal program memory depending on the requirements.

Once TBHP is enabled, the instruction "TABRDC [m]" reads the ROM data as defined by TBLP and TBHP value. Otherwise, the configuration option TBHP is disabled, the instruction "TABRDC [m]" reads the ROM data as defined by TBLP and the current program counter bits.

Table Program Example

The following example shows how the table pointer and table data is defined and retrieved from the microcontroller. This example uses raw table data located in the last page which is stored there using the ORG statement. The value at this ORG statement is "F00H" which refers to the start address of the last page within the 4K Program Memory of device. The table pointer is setup here to have an initial value of "06H". This will ensure that the first data read from the data table will be at the Program Memory address "F06H" or 6 locations after the start of the last page. Note that the value for the table pointer is referenced to the first address of the present page if the "TABRDC [m]" instruction is being used. The high byte of the table data which in this case is equal to zero will be transferred to the TBLH register automatically when the "TABRDL [m]" instruction is executed.

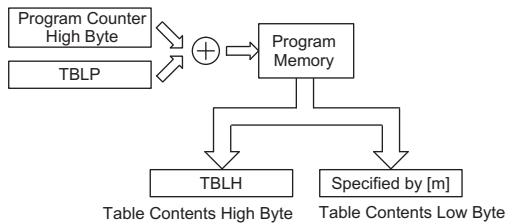

Table Read – TBLP only

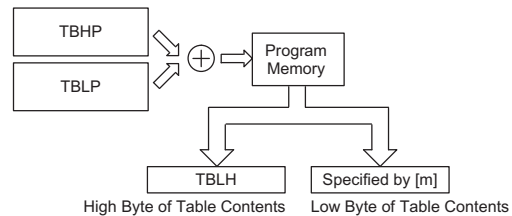

Table Read – TBLP/TBHP

```

tempreg1 db ? ; temporary register #1
tempreg2 db ? ; temporary register #2
:
:
mov a,06h ; initialise table pointer - note that this address
; is referenced
mov tblp,a ; to the last page or present page
:
:
tabrdl tempreg1 ; transfers value in table referenced by table pointer
; to tempreg1
; data at prog. memory address "F06H" transferred to
; tempreg1 and TBLH
dec tblp ; reduce value of table pointer by one
tabrdl tempreg2 ; transfers value in table referenced by table pointer
; to tempreg2
; data at prog.memory address "F05H" transferred to
; tempreg2 and TBLH
; in this example the data "1AH" is transferred to
; tempreg1 and data "0FH" to register tempreg2
; the value "00H" will be transferred to the high byte
; register TBLH
:
:
org F00h ; sets initial address of last page
dc 00Ah, 00Bh, 00Ch, 00Dh, 00Eh, 00Fh, 01Ah, 01Bh
:
:

```

Because the TBLH register is a read-only register and cannot be restored, care should be taken to ensure its protection if both the main routine and Interrupt Service Routine use the table read instructions. If using the table read instructions, the Interrupt Service Routines may change the value of TBLH and subsequently cause errors if used again by the main routine. As a rule it is recommended that simultaneous use of the table read instructions should be avoided. However, in situations where simultaneous use cannot be avoided, the interrupts should be disabled prior to the execution of any main routine table-read instructions. Note that all table related instructions require two instruction cycles to complete their operation.

Data Memory

The Data Memory is a volatile area of 8-bit wide RAM internal memory and is the location where temporary information is stored. Divided into two sections, the first of these is an area of RAM where special function registers are located. These registers have fixed locations and are necessary for correct operation of the device. Many of these registers can be read from and written to directly under program control, however, some remain protected from user manipulation. The second area of Data Memory is reserved for general purpose use. All locations within this area are read and write accessible under program control.

Structure

The two sections of Data Memory, the Special Purpose and General Purpose Data Memory are located at consecutive locations. All are implemented in RAM and are 8-bit wide. The start address of the Data Memory for all devices is the address "00H". Registers which are common to all microcontrollers, such as ACC, PCL, etc., have the same Data Memory address.

General Purpose Data Memory

All microcontroller programs require an area of read/write memory where temporary data can be stored and retrieved for use later. It is this area of RAM memory that is known as General Purpose Data Memory. This area of Data Memory is fully accessible by the user program for both read and write operations. By using the "SET [m].i" and "CLR [m].i" instructions, individual bits can be set or reset under program control giving the user a large range of flexibility for bit manipulation in the Data Memory.

Special Purpose Data Memory

This area of Data Memory is where registers, necessary for the correct operation of the microcontroller, are stored. Most of the registers are both readable and writeable but some are protected and are readable only, the details of which are located under the relevant Special Function Register section. Note that for locations that are unused, any read instruction to these addresses will return the value "00H".

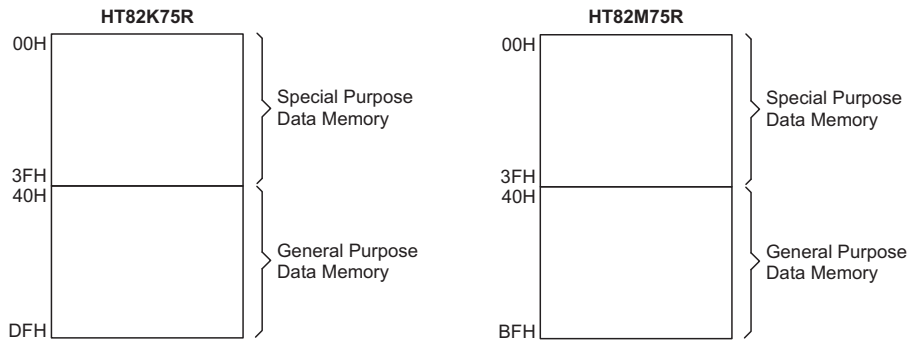

Data Memory Structure

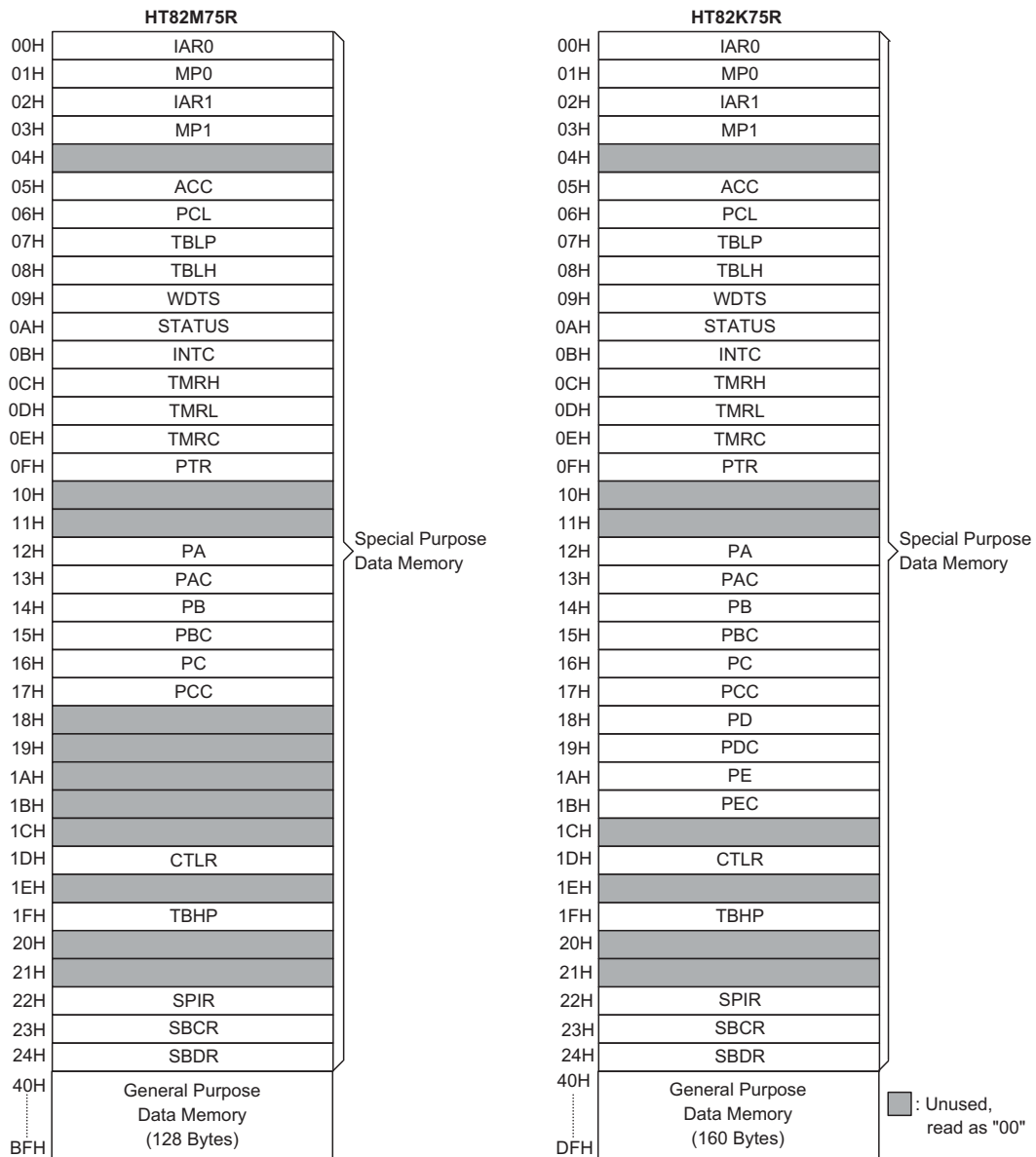

Special Function Registers

To ensure successful operation of the microcontroller, certain internal registers are implemented in the Data Memory area. These registers ensure correct operation of internal functions such as timers, interrupts, etc., as well as external functions such as I/O data control. The location of these registers within the Data Memory begins at the address 00H. Any unused Data Memory locations between these special function registers and the point where the General Purpose Memory begins is reserved and attempting to read data from these locations will return a value of 00H.

Indirect Addressing Register – IAR0, IAR1

The Indirect Addressing Registers, IAR0 and IAR1, although having their locations in normal RAM register space, do not actually physically exist as normal registers. The method of indirect addressing for RAM data manipulation uses these Indirect Addressing Registers and Memory Pointers, in contrast to direct memory addressing, where the actual memory address is specified. Actions on the IAR0 and IAR1 registers will result in no actual read or write operation to these registers but rather to the memory location specified by their corresponding Memory Pointer, MP0 or MP1. Acting as a

pair, IAR0 and MP0 can together only access data from Bank 0, while the IAR1 and MP1 register pair can access data from all of the data banks if the Data Memory is divided into 2 or more banks. As the Indirect Addressing Registers are not physically implemented, reading the Indirect Addressing Registers indirectly will return a result of "00H" and writing to the registers indirectly will result in no operation.

Memory Pointer – MP0, MP1

For all devices, two Memory Pointers, known as MP0 and MP1 are provided. These Memory Pointers are physically implemented in the Data Memory and can be manipulated in the same way as normal registers providing a convenient way with which to address and track data. When any operation to the relevant Indirect Addressing Registers is carried out, the actual address that the microcontroller is directed to, is the address specified by the related Memory Pointer. MP0 can only access data in Bank 0 while MP1 can access all data banks if the Data Memory is divided into 2 or more banks.

```
data .section 'data'
adres1      db ?
adres2      db ?
adres3      db ?
adres4      db ?
block       db ?
code .section at 0 'code'
org 00h

start:
    mov a,04h           ; setup size of block
    mov block,a
    mov a,offset adres1; Accumulator loaded with first RAM address
    mov mp,a           ; setup memory pointer with first RAM address

loop:
    clr IAR0           ; clear the data at address defined by MP0
    inc mp0            ; increment memory pointer
    sdz block          ; check if last memory location has been cleared
    jmp loop

continue:
```

The important point to note here is that in the example shown above, no reference is made to specific Data Memory addresses.

Accumulator – ACC

The Accumulator is central to the operation of any microcontroller and is closely related with operations carried out by the ALU. The Accumulator is the place where all intermediate results from the ALU are stored. Without the Accumulator it would be necessary to write the result of each calculation or logical operation such as addition, subtraction, shift, etc., to the Data Memory resulting in higher programming and timing overheads. Data transfer operations usually involve the temporary storage function of the Accumulator; for example, when transferring data between one user defined register and another, it is necessary to do this by passing the data through the Accumulator as no direct transfer between two registers is permitted.

Program Counter Low Register – PCL

To provide additional program control functions, the low byte of the Program Counter is made accessible to programmers by locating it within the Special Purpose area of the Data Memory. By manipulating this register, direct jumps to other program locations are easily implemented. Loading a value directly into this PCL register will cause a jump to the specified Program Memory location, however, as the register is only 8-bit wide, only jumps within the current Program Memory page are permitted. When such operations are used, note that a dummy cycle will be inserted.

Look-up Table Registers – TBLP, TBLH, TBHP

These two special function registers are used to control operation of the look-up table which is stored in the Program Memory. TBLP is the table pointer and indicates the location where the table data is located. Its value must be setup before any table read commands are executed. Its value can be changed, for example using the "INC" or "DEC" instructions, allowing for easy table data pointing and reading. TBLH is the location where the high order byte of the table data is stored after a table read data instruction has been executed. Note that the lower order table data byte is transferred to a user defined location. Once TBHP is enabled, the instruction "TABRDC [m]" reads the ROM data as defined by TBLP and TBHP value.

Otherwise, the configuration option TBHP is disabled, the instruction "TABRDC [m]" reads the ROM data as defined by TBLP and the current program counter bits.

Status Register – STATUS

This 8-bit register contains the zero flag (Z), carry flag (C), auxiliary carry flag (AC), overflow flag (OV), power down flag (PDF), and watchdog time-out flag (TO). These arithmetic/logical operation and system management flags are used to record the status and operation of the microcontroller.

With the exception of the TO and PDF flags, bits in the status register can be altered by instructions like most other registers. Any data written into the status register will not change the TO or PDF flag. In addition, operations related to the status register may give different results due to the different instruction operations. The TO flag can be affected only by a system power-up, a WDT time-out or by executing the "CLR WDT" or "HALT" instruction. The PDF flag is affected only by executing the "HALT" or "CLR WDT" instruction or during a system power-up.

The Z, OV, AC and C flags generally reflect the status of the latest operations.

- **C** is set if an operation results in a carry during an addition operation or if a borrow does not take place during a subtraction operation; otherwise C is cleared. C is also affected by a rotate through carry instruction.
- **AC** is set if an operation results in a carry out of the low nibbles in addition, or no borrow from the high nibble into the low nibble in subtraction; otherwise AC is cleared.
- **Z** is set if the result of an arithmetic or logical operation is zero; otherwise Z is cleared.
- **OV** is set if an operation results in a carry into the highest-order bit but not a carry out of the highest-order bit, or vice versa; otherwise OV is cleared.
- **PDF** is cleared by a system power-up or executing the "CLR WDT" instruction. PDF is set by executing the "HALT" instruction.
- **TO** is cleared by a system power-up or executing the "CLR WDT" or "HALT" instruction. TO is set by a WDT time-out.

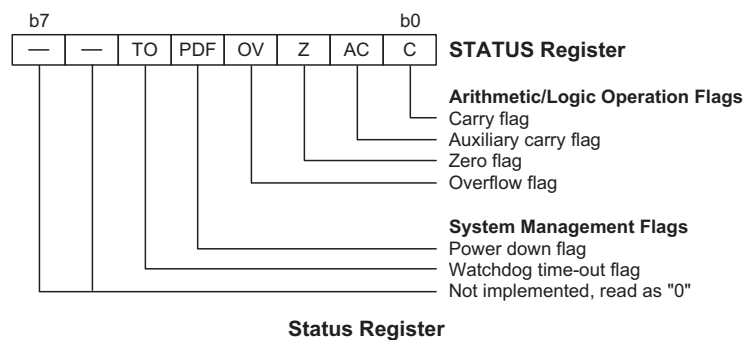

In addition, on entering an interrupt sequence or executing a subroutine call, the status register will not be pushed onto the stack automatically. If the contents of the status registers are important and if the interrupt routine can change the status register, precautions must be taken to correctly save it.

Interrupt Control Registers – INTC

The microcontroller provides an internal timer/event counter overflow interrupt. By setting various bits within this register using standard bit manipulation instructions, the enable/disable function of each interrupt can be independently controlled. A master interrupt bit within this register, the EMI bit, acts like a global enable/disable and is used to set all of the interrupt enable bits on or off. This bit is cleared when an interrupt routine is entered to disable further interrupt and is set by executing the "RETI" instruction.

Timer/Event Counter Registers – TMRH, TMRL, TMRC

All devices possess a single internal 16-bit count-up timer. An associated register pair known as TMRL/TMRH is the location where the timer 16-bit value is located. This register can also be preloaded with fixed data to allow different time intervals to be setup. An associated control register, known as TMRC, contains the setup information for this timer, which determines in what mode the timer is to be used as well as containing the timer on/off control function.

Watchdog Timer Register – WDTS

The Watchdog function in the microcontroller provides an automatic reset function giving the microcontroller a means of protection against spurious jumps to incorrect Program Memory addresses. To implement this, a timer is provided within the microcontroller which will issue a reset command when its value overflows. To provide variable Watchdog Timer reset times, the Watchdog Timer clock source can be divided by various division ratios, the value of which is set using the WDTS register. By writing directly to this register, the appropriate division ratio for the Watchdog Timer clock source can be setup. Note that only the lower 3 bits are used to set division ratios between 1 and 128.

Input/Output Ports and Control Registers

Within the area of Special Function Registers, the I/O registers and their associated control registers play a prominent role. All I/O ports have correspondingly designated registers known as PA, PB, etc. These labeled I/O registers are mapped to specific addresses within the Data Memory as shown in the Data Memory table, which are used to transfer the appropriate output or input data on that port. With each I/O port there is an asso-

ciated control register known as PAC, PBC, etc., also mapped to specific addresses with the Data Memory.

Input/Output Ports

Holtek microcontrollers offer considerable flexibility on their I/O ports. With the input or output designation of every pin fully under user program control, pull-high options for all ports and Wake-up option for all I/O pins, the user is provided with an I/O structure to meet the needs of a wide range of application possibilities.

The microcontroller provides 24 or 40 bit bidirectional input/output lines labeled with port names known as PA, PB, etc. These I/O ports are mapped to the Data Memory with addresses as shown in the Special Purpose Data Memory table. All of these I/O lines can be used for input and output operations and one line as an input only. For input operation, these ports are non-latching, which means the inputs must be ready at the T2 rising edge of instruction "MOV A,[m]", where m denotes the port address. For output operation, all the data is latched and remains unchanged until the output latch is rewritten.

Pull-high Resistors

Many product applications require pull-high resistors for their switch inputs usually requiring the use of an external resistor. To eliminate the need for these external resistors, I/O pins, when configured as an input have the capability of being connected to an internal pull-high resistor. The pull-high resistors are selectable via configuration options and are implemented using weak PMOS transistors. The individual pull-high resistor is selected to be connected to each pin on Port A by a configuration option. A configuration option can determine if the pull-high resistors are connected to the lower significant four pins or higher significant four pins on each I/O port except Port A.

Port Pin Wake-up

If the HALT instruction is executed, the device will enter the Power Down Mode, where the system clock will stop resulting in power being conserved, a feature that is important for battery and other low-power applications. Various methods exist to wake-up the microcontroller, one of which is to change the logic condition on one of the port pins from high to low. After a HALT instruction forces the microcontroller into entering the Power Down Mode, the processor will remain in a low-power state until the logic condition of the selected wake-up pin on the port pin changes from high to low. This function is especially suitable for applications that can be woken up via external switches. All of the I/O pins can be configured to have the capability to wake-up the device by high to low and low to high edges using different configuring ways. It means once the I/O pin is configured to have the

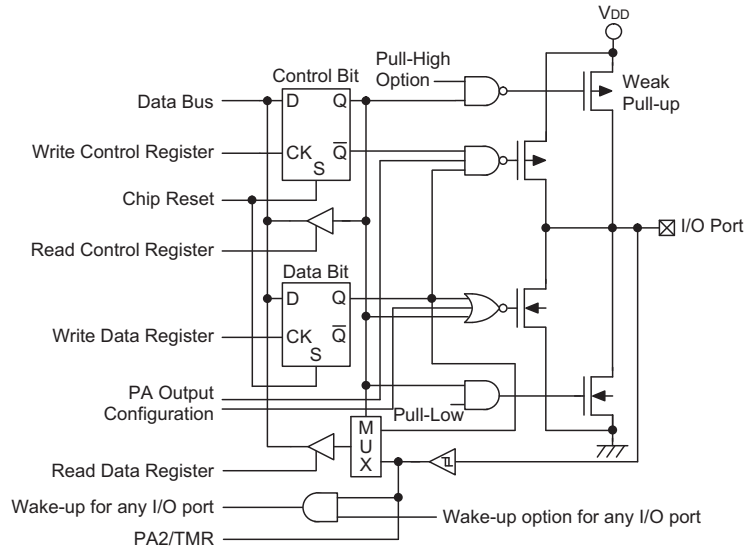

Input/Output Ports

wake-up capability, the device can be woken up by any I/O transition. For more details, refer to the Configuration Option Section later.

I/O Port Control Registers

Each I/O port has its own control register known as PAC, PBC, etc., to control the input/output configuration. With this control register, each CMOS/NMOS output or input with or without pull-high resistor structures can be re-configured dynamically under software control. Each of the I/O ports is directly mapped to a bit in its associated port control register. PC and PB can be set CMOS or NMOS output for option.

For the I/O pin to function as an input, the corresponding bit of the control register must be written as a "1". This will then allow the logic state of the input pin to be directly read by instructions. When the corresponding bit of the control register is written as a "0", the I/O pin will be setup as a CMOS/NMOS output. If the pin is currently setup as an output, instructions can still be used to read the output register. However, it should be noted that the program will in fact only read the status of the output data latch and not the actual logic status of the output pin.

Pin-shared Functions

The flexibility of the microcontroller range is greatly enhanced by the use of pins that have more than one function. Limited numbers of pins can force serious design constraints on designers but by supplying pins with multi-functions, many of these difficulties can be overcome. For some pins, the chosen function of the multi-function I/O pins is set by configuration options while for others the function is set by application pro-

gram control.

- External Timer Clock Input

The external timer pin TMR is pin-shared with the I/O pin PA2. To configure this pin to operate as timer input, the corresponding control bits in the timer control register must be correctly set. For applications that do not require an external timer input, this pin can be used as a normal I/O pin. Note that if used as a normal I/O pin the timer mode control bits in the timer control register must select the timer mode, which has an internal clock source, to prevent the input pin from interfering with the timer operation.

- External Interrupt Input

The external interrupt pin $\overline{\text{INT}}$ is pin-shared with the I/O pin PC2. For applications not requiring an external interrupt input, the pin-shared external interrupt pin can be used as a normal I/O pin, however to do this, the external interrupt enable bits in the INTC register must be disabled.

I/O Pin Structures

The diagrams illustrate the I/O pin internal structures. As the exact logical construction of the I/O pin may differ from these drawings, they are supplied as a guide only to assist with the functional understanding of the I/O pins.

Programming Considerations

Within the user program, one of the first things to consider is port initialisation. After a reset, all of the data and port control register will be set high. This means that all I/O pins will default to an input state, the level of which depends on the other connected circuitry and whether pull-high options have been selected. If the control registers, known as PAC, PBC, etc., are programmed to setup some pins as outputs, these output pins will have

an initial high output value unless the associated data registers are first programmed. Selecting which pins are inputs and which are outputs can be achieved byte-wide by loading the correct value into the port control register or by programming individual bits in the port control register using the "SET [m].i" and "CLR [m].i" instructions. Note that when using these bit control instructions, a read-modify-write operation takes place. The microcontroller must first read in the data on the entire port, modify it to the required new bit values and then re-write this data back to the output ports.

All I/O have the additional capability of providing wake-up functions. When the device is in the Power Down Mode, various methods are available to wake the device up. One of these is a high to low and low to high transition of any of the selected wake-up pins.

Timer/Event Counters

The provision of timers form an important part of any microcontroller giving the designer a means of carrying out time related functions. The device contains an internal 16-bit count-up timer which has three operating modes. The timer can be configured to operate as a general timer, external event counter or as a pulse width measurement device.

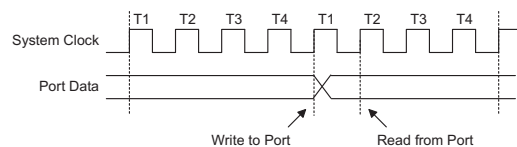

Read/Write Timing

There are three registers related to the Timer/Event Counter, TMRL, TMRH and TMRC. The TMRL/TMRH register pair are the registers that contains the actual timing value. Writing to this register pair places an initial starting value in the Timer/Event Counter preload register while reading retrieves the contents of the Timer/Event Counter. The TMRC register is a Timer/Event Counter control register, which defines the timer options, and determines how the timer is to be used. The timer clock source can be configured to come from the internal system clock divided by 4 or from an external clock on shared pin PA2/TMR.

Configuring the Timer/Event Counter Input Clock Source

The timer clock source can originate from either the system clock divided by 4 or from an external clock source. The system clock divided by 4 is used when the timer is in the timer mode or in the pulse width measurement mode.

An external clock source is used when the timer is in the event counting mode, the clock source being provided on shared pin PA2/TMR. Depending upon the condition

of the TE bit, each high to low, or low to high transition on the PA2/TMR pin will increment the counter by one.

Timer Registers – TMRH, TMRL

The TMRH and TMRL registers are two 8-bit special function register locations within the special purpose Data Memory where the actual timer value is stored. The value in the timer registers increases by one each time an internal clock pulse is received or an external transition occurs on the PA2/TMR pin. The timer will count from the initial value loaded by the preload register to the full count value of FFFFH at which point the timer overflows and an internal interrupt signal generated. The timer value will then be reset with the initial preload register value and continue counting. For a maximum full range count of 0000H to FFFFH the preload registers must first be cleared to 0000H. It should be noted that after power-on the preload registers will be in an unknown condition. Note that if the Timer/Event Counter is not running and data is written to its preload registers, this data will be immediately written into the actual counter. However, if the counter is enabled and counting, any new data written into the preload registers during this period will remain in the preload registers and will only be written into the actual counter the next time an overflow occurs.

Accessing these registers is carried out in a specific way. It must be noted that when using instructions to preload data into the low byte register, namely TMRL, the data will only be placed in a low byte buffer and not directly into the low byte register. The actual transfer of the data into the low byte register is only carried out when a write to its associated high byte register, namely TMRH, is executed. On the other hand, using instructions to preload data into the high byte timer register will result in the data being directly written to the high byte register. At the same time the data in the low byte buffer will be transferred into its associated low byte register. For this reason, when preloading data into the 16-bit timer registers, the low byte should be written first. It must also be noted that to read the contents of the low byte register, a read to the high byte register must first be executed to latch the contents of the low byte buffer from its associated low byte register. After this has been done, the low byte register can be read in the normal way. Note that reading the low byte timer register directly will only result in reading the previously latched contents of the low byte buffer and not the actual contents of the low byte timer register.

Timer Control Register – TMRC

The flexible features of the Holtek microcontroller Timer/Event Counters enable them to operate in three different modes, the options of which are determined by the contents of the Timer Control Register TMRC. Together with the TMRL and TMRH registers, these three

registers control the full operation of the Timer/Event Counter. Before the timer can be used, it is essential that the TMRC register is fully programmed with the right data to ensure its correct operation, a process that is normally carried out during program initialisation.

To choose which of the three modes the timer is to operate in, the timer mode, the event counting mode or the pulse width measurement mode, bits TM0 and TM1 must be set to the required logic levels. The timer-on bit TON or bit 4 of the TMRC register provides the basic on/off control of the timer, setting the bit high allows the counter to run, clearing the bit stops the counter. If the timer is in the event count or pulse width measurement mode the active transition edge level type is selected by the logic level of the TE or bit 3 of the TMRC register.

Configuring the Timer Mode

In this mode, the timer can be utilised to measure fixed time intervals, providing an internal interrupt signal each time the counter overflows. To operate in this mode, bits TM1 and TM0 of the TMRC register must be set to 1 and 0 respectively. In this mode, the internal clock is used as the timer clock. The timer-on bit, TON, must be set high to enable the timer to run. Each time an internal clock high to low transition occurs, the timer increments by one. When the timer is full and overflows, the timer will be reset to the value already loaded into the preload register and continue counting. If the timer interrupt is enabled, an interrupt signal will also be generated. The timer interrupt can be disabled by ensuring that the ETI bit in the INTC register is cleared to zero.

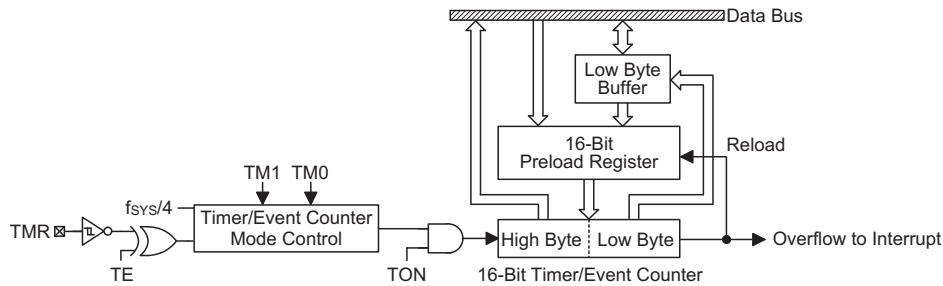

16-bit Timer/Event Counter Structure

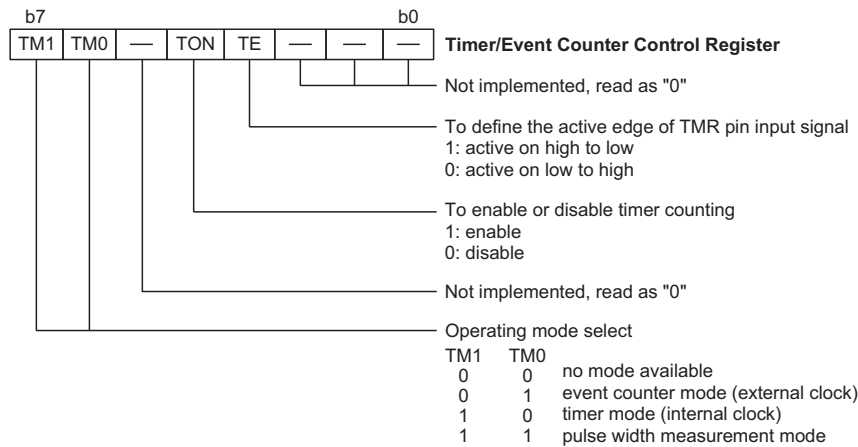

Timer/Event Counter Control Register

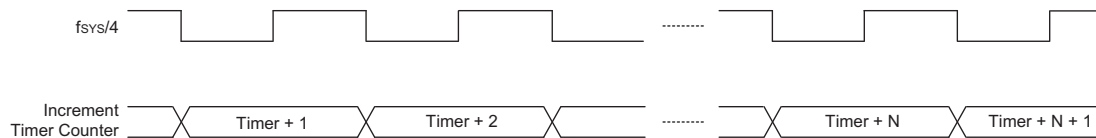

Timer Mode Timing Chart

Configuring the Event Counter Mode

In this mode, a number of externally changing logic events, occurring on external pin PA2/TMR, can be recorded by the internal timer. For the timer to operate in the event counting mode, bits TM1 and TM0 of the TMRC register must be set to 0 and 1 respectively. The timer-on bit, TON must be set high to enable the timer to count. With TE low, the counter will increment each time the PA2/TMR pin receives a low to high transition. If the TE bit is high, the counter will increment each time PA2/TMR receives a high to low transition. As in the case of the other two modes, when the counter is full and overflows, the timer will be reset to the value already loaded into the preload register and continue counting. If the timer interrupt is enabled, an interrupt signal will also be generated. The timer interrupt can be disabled by ensuring that the ETI bit in the INTC register is cleared to zero. To ensure that the external pin PA2/TMR is configured to operate as an event counter input pin, two things have to happen. The first is to ensure that the TM0 and TM1 bits place the timer/event counter in the event counting mode, the second is to ensure that the port control register configures the pin as an input. In the Event Counting mode, the Timer/Event Counter will continue to record externally changing logic events on the timer input pin, even if the microcontroller is in the Power Down Mode.

Configuring the Pulse Width Measurement Mode

In this mode, the width of external pulses applied to the pin-shared external pin PA2/TMR can be measured. In the Pulse Width Measurement Mode, the timer clock source is supplied by the internal clock. For the timer to operate in this mode, bits TM0 and TM1 must both be set high. If the TE bit is low, once a high to low transition has been received on the PA2/TMR pin, the timer will

start counting until the PA2/TMR pin returns to its original high level. At this point the TON bit will be automatically reset to zero and the timer will stop counting. If the TE bit is high, the timer will begin counting once a low to high transition has been received on the PA2/TMR pin and stop counting when the PA2/TMR pin returns to its original low level. As before, the TON bit will be automatically reset to zero and the timer will stop counting. It is important to note that in the Pulse Width Measurement Mode, the TON bit is automatically reset to zero when the external control signal on the external timer pin returns to its original level, whereas in the other two modes the TON bit can only be reset to zero under program control. The residual value in the timer, which can now be read by the program, therefore represents the length of the pulse received on pin PA2/TMR. As the TON bit has now been reset any further transitions on the PA2/TMR pin will be ignored. Not until the TON bit is again set high by the program can the timer begin further pulse width measurements. In this way single shot pulse measurements can be easily made. It should be noted that in this mode the counter is controlled by logical transitions on the PA2/TMR pin and not by the logic level.

As in the case of the other two modes, when the counter is full and overflows, the timer will be reset to the value already loaded into the preload register. If the timer interrupt is enabled, an interrupt signal will also be generated. To ensure that the external pin PA2/TMR is configured to operate as a pulse width measuring input pin, two things have to happen. The first is to ensure that the TM0 and TM1 bits place the timer/event counter in the pulse width measuring mode, the second is to ensure that the port control register configures the pin as an input.

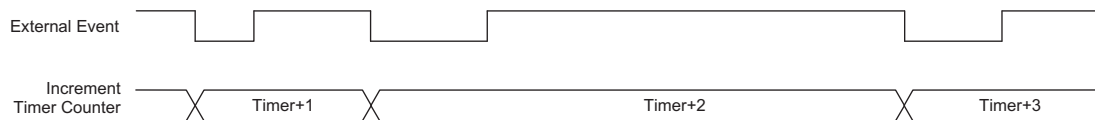

Event Counter Mode Timing Chart

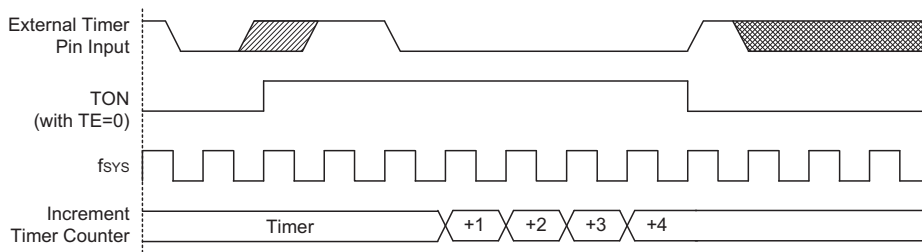

fsys is sampled at every falling edge of T1.

Pulse Width Measure Mode Timing Chart

I/O Interfacing

The Timer/Event Counter, when configured to run in the event counter or pulse width measurement mode, require the use of the external PA2 pin for correct operation. As this pin is a shared pin it must be configured correctly to ensure it is setup for use as a Timer/Event Counter input and not as a normal I/O pin. This is implemented by ensuring that the mode select bits in the Timer/Event Counter control register, select either the event counter or pulse width measurement mode. Additionally the Port Control Register PAC bit 2 must be set high to ensure that the pin is setup as an input. Any pull-high resistor configuration option on this pin will remain valid even if the pin is used as a Timer/Event Counter input.

Programming Considerations

When configured to run in the timer mode, the internal system clock is used as the timer clock source and is therefore synchronised with the overall operation of the microcontroller. In this mode when the appropriate timer register is full, the microcontroller will generate an internal interrupt signal directing the program flow to the respective internal interrupt vector. For the pulse width measurement mode, the internal system clock is also used as the timer clock source but the timer will only run when the correct logic condition appears on the external timer input pin. As this is an external event and not synchronised with the internal timer clock, the microcontroller will only see this external event when the next timer clock pulse arrives. As a result, there may be small differences in measured values requiring programmers to take this into account during programming. The same applies if the timer is configured to be in the event counting mode, which again is an external event and not synchronised with the internal system or timer clock.

When the Timer/Event Counter is read, or if data is written to the preload register, the clock is inhibited to avoid errors, however as this may result in a counting error, this should be taken into account by the programmer. Care must be taken to ensure that the timers are properly initialised before using them for the first time. The associated timer interrupt enable bits in the interrupt control register must be properly set otherwise the internal interrupt associated with the timer will remain inactive. The edge select, timer mode and clock source control bits in timer control register must also be correctly set to ensure the timer is properly configured for the required application. It is also important to ensure that an initial value is first loaded into the timer registers before the timer is switched on; this is because after power-on the initial values of the timer registers are unknown. After the timer has been initialised the timer can be turned on and off by controlling the enable bit in the timer control register. Note that setting the timer enable bit high to turn the timer on, should only be executed after the timer mode bits have been properly setup. Setting the timer enable bit high together with a mode bit modification, may lead to improper timer operation if executed as a single timer control register byte write instruction.

When the Timer/Event counter overflows, its corresponding interrupt request flag in the interrupt control register will be set. If the timer interrupt is enabled this will in turn generate an interrupt signal. But the timer for internal clock overflow can't wake up the MCU if MCU is in a Power down condition.

Timer Program Example

This program example shows how the Timer/Event Counter registers are setup, along with how the interrupts are enabled and managed. Note how the Timer/Event Counter is turned on, by setting bit 4 of the Timer Control Register. The Timer/Event Counter can be turned off in a similar way by clearing the same bit. This example program sets the Timer/Event Counter to be in the timer mode, which uses the internal system clock as the clock source.

```
org 04h
reti
org 08h          ; Timer/Event Counter interrupt vector
jmp tmrint      ; jump here when Timer overflows
:
org 20h          ; main program
; internal Timer/Event Counter interrupt routine
tmrint:
:
; Timer/Event Counter main program placed here
:
reti
:
:
begin:
; setup Timer registers
mov a, 09bh     ; setup Timer low register
mov tmrl, a;    ; load low register first
mov a, 0aah     ; setup timer high register
mov tmrh, a
mov a, 080h     ; setup Timer control register
mov tmrc, a    ; timer mode is used
; setup interrupt register
mov a, 005h     ; enable master interrupt and timer interrupt
mov intc, a
set tmrc.4     ; start Timer/Event Counter - note mode bits must be previously setup
```

Interrupts

Interrupts are an important part of any microcontroller system. When an internal function such as a Timer/Event Counter overflow, their corresponding interrupt will enforce a temporary suspension of the main program allowing the microcontroller to direct attention to their respective needs. These devices contain several interrupts generated by internal interrupts events and external interrupt.

Interrupt Register

Overall interrupt control, which means interrupt enabling and request flag setting, is controlled by a single interrupt control register, which is located in the Data Memory. By controlling the appropriate enable bits in this register the interrupt can be enabled or disabled. Also when an interrupt occurs, the request flag will be set by the microcontroller. The global enable bit if cleared to zero will disable all interrupts.

Interrupt Operation

A Timer/Event Counter overflow, will generate an interrupt request by setting its corresponding request flag, if its interrupt enable bit is set. When this happens, the Program Counter, which stores the address of the next instruction to be executed, will be transferred onto the stack. The Program Counter will then be loaded with a

new address which will be the value of the corresponding interrupt vector. The microcontroller will then fetch its next instruction from this interrupt vector. The instruction at this vector will usually be a JMP statement which will jump to another section of program which is known as the interrupt service routine. Here is located the code to control the appropriate interrupt. The interrupt service routine must be terminated with a RETI statement, which retrieves the original Program Counter address from the stack and allows the microcontroller to continue with normal execution at the point where the interrupt occurred.

Once an interrupt subroutine is serviced, other interrupts will be blocked, as the EMI bit will be cleared automatically. This will prevent any further interrupt nesting from occurring. However, if other interrupt requests occur during this interval, although the interrupt will not be immediately serviced, the request flag will still be recorded. If an interrupt requires immediate servicing while the program is already in another interrupt service routine, the EMI bit should be set after entering the routine, to allow interrupt nesting. If the stack is full, the interrupt request will not be acknowledged, even if the related interrupt is enabled, until the Stack Pointer is decremented. If immediate service is desired, the stack must be prevented from becoming full.

Timer/Event Counter Interrupt

For a Timer/Event Counter interrupt to occur, the global interrupt enable bit, EMI, and its corresponding timer interrupt enable bit, ETI, must first be set. An actual Timer/Event Counter interrupt will take place when the Timer/Event Counter request flag, TF, is set, a situation that will occur when the Timer/Event Counter overflows. When the interrupt is enabled, the stack is not full and a Timer/Event Counter overflow occurs, a subroutine call to the timer interrupt vector at location 08H, will take place. When the interrupt is serviced, the timer interrupt request flag, TF, will be automatically reset and the EMI bit will be automatically cleared to disable other interrupts.

Programming Considerations

By disabling the interrupt enable bit, the requested interrupt can be prevented from being serviced, however, once an interrupt request flag is set, it will remain in this

condition in the interrupt control register until the corresponding interrupt is serviced or until the request flag is cleared by a software instruction.

It is recommended that programs do not use the "CALL subroutine" instruction within the interrupt subroutine. Interrupts often occur in an unpredictable manner or need to be serviced immediately in some applications. If only one stack is left and the interrupt is not well controlled, the original control sequence will be damaged once a "CALL subroutine" is executed in the interrupt subroutine.

All of these interrupts have the capability of waking up the processor when in the Power Down Mode.

Only the Program Counter is pushed onto the stack. If the contents of the accumulator or status register are altered by the interrupt service program, which may corrupt the desired control sequence, then the contents should be saved in advance.

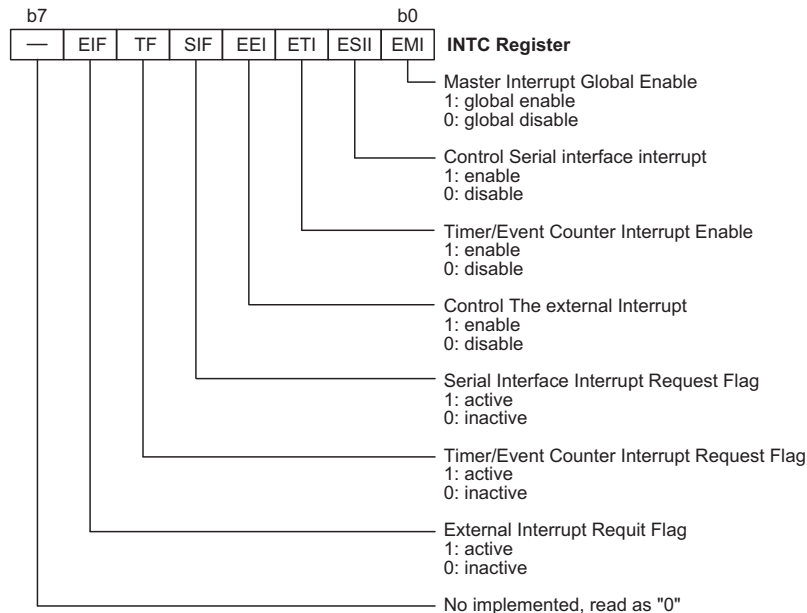

Interrupt Control Register

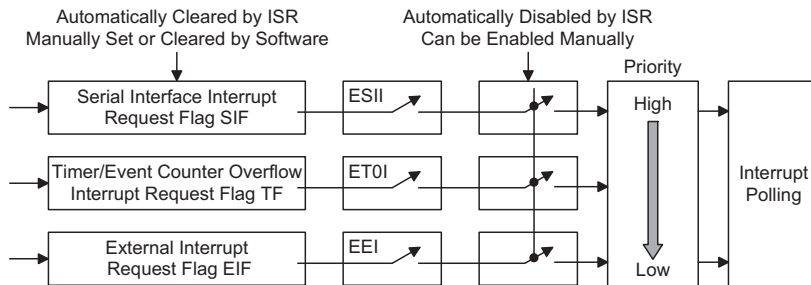

Interrupt Structure

Reset and Initialisation

A reset function is a fundamental part of any microcontroller ensuring that the device can be set to some predetermined condition irrespective of outside parameters. The most important reset condition is after power is first applied to the microcontroller. In this case, internal circuitry will ensure that the microcontroller, after a short delay, will be in a well defined state and ready to execute the first program instruction. After this power-on reset, certain important internal registers will be set to defined states before the program commences. One of these registers is the Program Counter, which will be reset to zero forcing the microcontroller to begin program execution from the lowest Program Memory address.

In addition to the power-on reset, situations may arise where it is necessary to forcefully apply a reset condition when the microcontroller is running. One example of this is where after power has been applied and the microcontroller is already running, the RES line is forcefully pulled low. In such a case, known as a normal operation reset, some of the microcontroller registers remain unchanged allowing the microcontroller to proceed with normal operation after the reset line is allowed to return high. Another type of reset is when the Watchdog Timer overflows and resets the microcontroller. All types of reset operations result in different register conditions being setup.

Another reset exists in the form of a Low Voltage Reset, LVR, where a full reset, similar to the RES reset is implemented in situations where the power supply voltage falls below a certain threshold.

Reset Functions

There are five ways in which a microcontroller reset can occur, through events occurring both internally and externally:

- Power-on Reset

The most fundamental and unavoidable reset is the one that occurs after power is first applied to the microcontroller. As well as ensuring that the Program Memory begins execution from the first memory address, a power-on reset also ensures that certain other registers are preset to known conditions. All the I/O port and port control registers will power up in a high condition ensuring that all pins will be first set to inputs.

Although the microcontroller has an internal RC reset function, if the VDD power supply rise time is not fast enough or does not stabilise quickly at power-on, the internal reset function may be incapable of providing proper reset operation. For this reason it is recommended that an external RC network is connected to the RES pin, whose additional time delay will ensure that the RES pin remains low for an extended period to allow the power supply to stabilise. During this time delay, normal operation of the microcontroller will be

inhibited. After the RES line reaches a certain voltage value, the reset delay time t_{RSTD} is invoked to provide an extra delay time after which the microcontroller will begin normal operation. The abbreviation SST in the figures stands for System Start-up Timer.

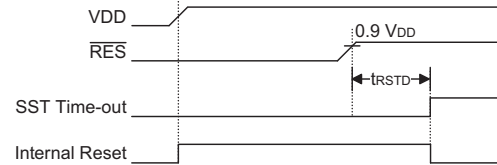

Power-On Reset Timing Chart

For most applications a resistor connected between VDD and the RES pin and a capacitor connected between VSS and the RES pin will provide a suitable external reset circuit. Any wiring connected to the RES pin should be kept as short as possible to minimise any stray noise interference.

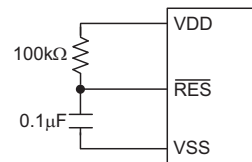

Basic Reset Circuit

For applications that operate within an environment where more noise is present the Enhanced Reset Circuit shown is recommended.

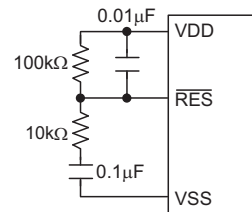

Enhanced Reset Circuit

More information regarding external reset circuits is located in Application Note HA0075E on the Holtek website.

- RES Pin Reset

This type of reset occurs when the microcontroller is already running and the RES pin is forcefully pulled low by external hardware such as an external switch. In this case as in the case of other reset, the Program Counter will reset to zero and program execution initiated from this point.

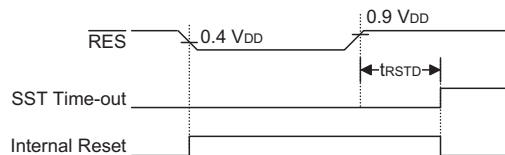

RES Reset Timing Chart

• Low Voltage Reset – LVR

The microcontroller contains a low voltage reset circuit in order to monitor the supply voltage of the device. The LVR function is selected via a configuration option. If the supply voltage of the device drops to within a range of $0.9V \sim V_{LVR}$ such as might occur when changing the battery, the LVR will automatically reset the device internally. For a valid LVR signal, a low supply voltage, i.e., a voltage in the range between $0.9V \sim V_{LVR}$ must exist for a time greater than that specified by t_{LVR} in the A.C. characteristics. If the low supply voltage state does not exceed this value, the LVR will ignore the low supply voltage and will not perform a reset function. The actual V_{LVR} value can be selected via configuration options.

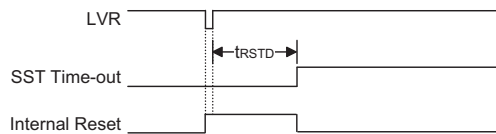

Low Voltage Reset Timing Chart

- Watchdog Time-out Reset during Normal Operation
The Watchdog time-out Reset during normal operation is the same as a hardware \overline{RES} pin reset except that the Watchdog time-out flag TO will be set to "1".

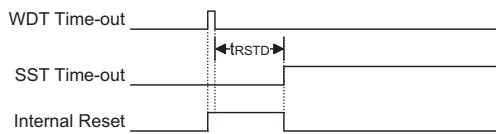

WDT Time-out Reset during Normal Operation Timing Chart

- Watchdog Time-out Reset during Power Down
The Watchdog time-out Reset during Power Down is a little different from other kinds of reset. Most of the conditions remain unchanged except that the Program Counter and the Stack Pointer will be cleared to "0" and the TO flag will be set to "1". Refer to the A.C. Characteristics for t_{SST} details.

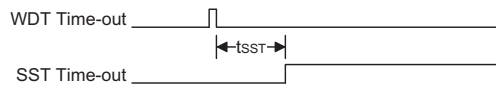

WDT Time-out Reset during Power Down Timing Chart

Reset Initial Conditions

The different types of reset described affect the reset flags in different ways. These flags, known as PDF and TO are located in the status register and are controlled by various microcontroller operations, such as the Power Down function or Watchdog Timer. The reset flags are shown in the table:

| TO | PDF | RESET Conditions |
|----|-----|---|
| 0 | 0 | \overline{RES} reset during power-on |
| 0 | 1 | \overline{RES} wake-up HALT |
| u | u | \overline{RES} or LVR reset during normal operation |
| 1 | u | WDT time-out reset during normal operation |
| 1 | 1 | WDT time-out reset during Power Down |

Note: "u" stands for unchanged

The following table indicates the way in which the various components of the microcontroller are affected after a power-on reset occurs.

| Item | Condition After RESET |
|---------------------|--|
| Program Counter | Reset to zero |
| Interrupts | All interrupts will be disabled |
| WDT | Clear after reset, WDT begins counting |
| Timer/Event Counter | Timer Counter will be turned off |
| Input/Output Ports | I/O ports will be setup as inputs |
| Stack Pointer | Stack Pointer will point to the top of the stack |

The different kinds of resets all affect the internal registers of the microcontroller in different ways. To ensure reliable continuation of normal program execution after a reset occurs, it is important to know what condition the microcontroller is in after a particular reset occurs. The following table describes how each type of reset affects each of the microcontroller internal registers.

| Register | Reset (Power-on) | WDT time-out (Normal Operation) | RES Reset (Normal Operation) | RES Reset (HALT) | WDT Time-out (HALT)* |
|----------|------------------|---------------------------------|------------------------------|------------------|----------------------|
| PCL | 000H | 000H | 000H | 000H | 000H |
| ACC | xxxx xxxx | uuuu uuuu | uuuu uuuu | uuuu uuuu | uuuu uuuu |
| TBLP | xxxx xxxx | uuuu uuuu | uuuu uuuu | uuuu uuuu | uuuu uuuu |
| TBLH | -xxx xxxx | -uuu uuuu | -uuu uuuu | -uuu uuuu | -uuu uuuu |
| STATUS | --00 xxxx | --1u uuuu | --uu uuuu | --01 uuuu | --11 uuuu |
| INTC | -000 0000 | -000 0000 | -000 0000 | -000 0000 | -uuu uuuu |
| TMRL | xxxx xxxx | xxxx xxxx | xxxx xxxx | xxxx xxxx | uuuu uuuu |
| TMRH | xxxx xxxx | xxxx xxxx | xxxx xxxx | xxxx xxxx | uuuu uuuu |
| TMRC | 00-0 1---- | 00-0 1---- | 00-0 1---- | 00-0 1---- | uu-u u--- |
| PA | 1111 1111 | 1111 1111 | 1111 1111 | 1111 1111 | uuuu uuuu |
| PAC | 1111 1111 | 1111 1111 | 1111 1111 | 1111 1111 | uuuu uuuu |
| PB | 1111 1111 | 1111 1111 | 1111 1111 | 1111 1111 | uuuu uuuu |
| PBC | 1111 1111 | 1111 1111 | 1111 1111 | 1111 1111 | uuuu uuuu |
| PC | 1111 1111 | 1111 1111 | 1111 1111 | 1111 1111 | uuuu uuuu |
| PCC | 1111 1111 | 1111 1111 | 1111 1111 | 1111 1111 | uuuu uuuu |
| PD ** | 1111 1111 | 1111 1111 | 1111 1111 | 1111 1111 | uuuu uuuu |
| PDC ** | 1111 1111 | 1111 1111 | 1111 1111 | 1111 1111 | uuuu uuuu |
| PE ** | 1111 1111 | 1111 1111 | 1111 1111 | 1111 1111 | uuuu uuuu |
| PEC ** | 1111 1111 | 1111 1111 | 1111 1111 | 1111 1111 | uuuu uuuu |
| WDS | ---- -111 | ---- -111 | ---- -111 | ---- -111 | ---- -uuu |
| MP0 | xxxx xxxx | uuuu uuuu | uuuu uuuu | uuuu uuuu | uuuu uuuu |
| MP1 | xxxx xxxx | uuuu uuuu | uuuu uuuu | uuuu uuuu | uuuu uuuu |
| CTLR | 0100 0x00 | 0100 0x00 | 0100 0x00 | 0100 0x00 | uuuu uxuu |
| PTR | 0000 0000 | 0000 0000 | 0000 0000 | 0000 0000 | uuuu uuuu |
| TBHP | ---- 0000 | ---- 0000 | ---- 0000 | ---- 0000 | 0000 uuuu |
| SPIR | 0000 0000 | 0000 0000 | 0000 0000 | 0000 0000 | 0000 uuuu |
| SBCR | 0110 0000 | 0110 0000 | 0110 0000 | 0110 0000 | uuuu uuuu |
| SBDR | xxxx xxxx | xxxx xxxx | xxxx xxxx | xxxx xxxx | uuuu uuuu |

Note: **** For the HT82K75R only

"-" not implemented

"u" means "unchanged"

"x" means "unknown"

Oscillator

The clock source for these devices is provided by an integrated oscillator requiring no external components.

This oscillator has one fixed frequencies of 6MHz.

Watchdog Timer Oscillator

The WDT oscillator is a fully self-contained free running on-chip RC oscillator with a typical period of 71 μ s at 3V requiring no external components. When the device enters the Power Down Mode, the system clock will stop running but the WDT oscillator continues to free-run and to keep the watchdog active. However, to preserve power in certain applications the WDT oscillator can be disabled via a configuration option.

Power Down Mode and Wake-up

Power Down Mode

All of the Holtek microcontrollers have the ability to enter a Power Down Mode. When the device enters this mode, the normal operating current, will be reduced to an extremely low standby current level. This occurs because when the device enters the Power Down Mode, the system oscillator is stopped which reduces the power consumption to extremely low levels, however, as the device maintains its present internal condition, it can be woken up at a later stage and continue running, without requiring a full reset. This feature is extremely important in application areas where the microcontroller must have its power supply constantly maintained to keep the device in a known condition but where the power supply capacity is limited such as in battery applications.

Entering the Power Down Mode

There is only one way for the device to enter the Power Down Mode and that is to execute the "HALT" instruction in the application program. When this instruction is executed, the following will occur:

- The system oscillator will stop running and the application program will stop at the "HALT" instruction.
- The Data Memory contents and registers will maintain their present condition.
- The WDT will be cleared and resume counting if the WDT function is enabled.
- The I/O ports will maintain their present condition.
- In the status register, the Power Down flag, will be set and the Watchdog time-out flag, TO, will be cleared.

Standby Current Considerations

As the main reason for entering the Power Down Mode is to keep the current consumption of the microcontroller to as low a value as possible, perhaps only in the order of several micro-amps, there are other considerations which must also be taken into account by the circuit de-

signer if the power consumption is to be minimised.

Special attention must be made to the I/O pins on the device. All high-impedance input pins must be connected to either a fixed high or low level as any floating input pins could create internal oscillations and result in increased current consumption. Care must also be taken with the loads, which are connected to I/O pins, which are setup as outputs. These should be placed in a condition in which minimum current is drawn or connected only to external circuits that do not draw current, such as other CMOS inputs.

If the configuration option has enabled the Watchdog Timer internal oscillator, then the Watchdog Timer will continue to run when in the Power Down Mode and will thus consume some power.

Wake-up

After the system enters the Power Down Mode, it can be woken up from one of various sources listed as follows:

- An external reset
- An external falling or rising edge on any of the I/O pins
- A system interrupt
- A WDT overflow (if the contents of the PTR are zeros)
- A PTR overflow occurs (if the contents of the PTR are not equal to zeros)

If the system is woken up by an external reset, the device will experience a full system reset, however, if the device is woken up by a WDT overflow, a Watchdog Timer reset will be initiated. Although both of these wake-up methods will initiate a reset operation, the actual source of the wake-up can be determined by examining the TO and PDF flags. The PDF flag is cleared by a system power-up or executing the clear Watchdog Timer instructions and is set when executing the "HALT" instruction. The TO flag is set if a WDT time-out occurs, and causes a wake-up that only resets the Program Counter and Stack Pointer, the other flags remain in their original status. Note that the WDT time-out will not occur if the contents of the Period Timer Register (PTR) are not equal to zeros.

Each pin on Port A or any nibble on other ports can be setup via configuration options to permit a negative or positive transition on the pin to wake-up the system. When a port pin wake-up occurs, the program will resume execution at the instruction following the "HALT" instruction.

If the system is woken up by an interrupt, then two possible situations may occur. The first is where the interrupt is disabled or the interrupt is enabled but the stack is full, in which case the program will resume execution at the instruction following the "HALT" instruction. In this situation, the interrupt will not be immediately serviced, but will rather be serviced later when the related interrupt is

finally enabled or when a stack level becomes free. The other situation is where the related interrupt is enabled and the stack is not full, in which case the regular interrupt response takes place. If an interrupt request flag is set to "1" before entering the Power Down Mode, the wake-up function of the related interrupt will be disabled.

No matter what the source of the wake-up event is, once a wake-up situation occurs, a time period equal to 512 system clock periods will be required before normal system operation resumes. However, if the wake-up has originated due to an interrupt, the actual interrupt sub-routine execution will be delayed by additional one or more cycles. If the wake-up results in the execution of the next instruction following the "HALT" instruction, this will be executed immediately after the 512 system clock period delay has ended.

Watchdog Timer

The Watchdog Timer is provided to prevent program malfunctions or sequences from jumping to unknown locations, due to certain uncontrollable external events such as electrical noise. It operates by providing a device reset when the WDT counter overflows. The WDT clock is supplied by its own internal dedicated internal WDT oscillator. Note that if the WDT configuration option has been disabled, then any instruction relating to its operation will result in no operation.

The WDT function is selected by a configuration option. There is also an internal register associated with the WDT named WDTS to disable the Watchdog Timer function and select various WDT time-out periods in the device. The clock source of the WDT comes from the in-

ternal WDT oscillator and its clock period may vary with VDD, temperature and process variation. The WDT clock is further divided by an internal 6-stage counter followed by a 7-stage prescaler to obtain longer WDT time-out period selected by the WDT prescaler rate selection bits, WS2~WS0, in the associated WDT register known as WDTS.

There is only one instruction to clear the Watchdog Timer known as "CLR WDT". As the instruction "CLR WDT" is executed, all contents of the 6-stage counter and 7-stage prescaler will be clear. It makes the WDT time-out period more accurate relatively.

Under normal program operation, a WDT time-out will initialise a device reset and set the status bit TO. However, if the system is in the Power Down Mode, when a WDT time-out occurs, the TO bit in the status register will be set and only the Program Counter and Stack Pointer will be reset. Three methods can be adopted to clear the contents of the WDT. The first is an external hardware reset, which means a low level on the \overline{RES} pin, the second is using the watchdog software instructions and the third is via a HALT instruction.

Although the WDT overflow is a source to wake up the MCU from the Power Down Mode, there are some limitations on the conditions at which the WDT overflow occurs. If the WDT function is enabled and the PTR contents are equal to zeros, the WDT overflow will occur to wake up the MCU from the Power Down Mode. If the PTR contents are not equal to zeros, the WDT overflow will not occur in Power Down Mode even if the WDT function has been enabled.

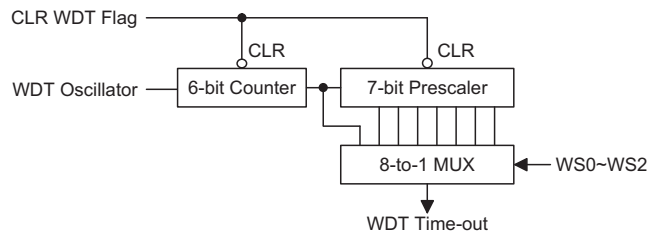

Watchdog Timer

| Bit No. | Func. Name | R/W | Description |
|-------------|-----------------|-----|---|
| 0 | CNT_WK | R | 0: MCU wakeup not by period counter 1: MCU wakeup by period counter overflow (Read only) |
| 1 | DC_Ctrl | R/W | This bit is used to decide whether the DC block is in operation 0: enable DC_DC output (default) 1: disable DC_DC output |
| 2 | 2.2 Low Battery | R | Flag for 2.2V battery low signal coming from DC/DC block (error $\pm 5\%$) 0: battery voltage > 2.2 or 2.0V 1: battery voltage \leq 2.2 or 2.0 V |
| 3 4 | Clock_div | R/W | 00: CLK/1=6MHz (default) 01: CLK/2=3MHz 10: CLK/4=1.5MHz 11: CLK/4=1.5MHz |
| 5 6 7 | LVD_Set | R/W | LVD detect voltage select 000: 1.8V 001: 2.0V 010: 2.2V (default) 011: 2.5V 100: 2.8V |

Control Register CTLR

Period Timer Register – PTR

This register is used to define the period of the timer which always counts in the Power Down mode. Once the timer is reached, the MCU will be woken-up by Period Timer Register overflow. Once the MCU is woken-up by the period timer, the CNT_WK bit of the wake-up Register is set to "1".

| Bit No. | Function Name | R/W | Description |
|---------|---------------|-----|---|
| 0~7 | Period Timer | R/W | The Period Timer is the time interval generator with one second as a unit. If the bits [7:0] are equal to 00H, the MCU will be woken up by one of the wake-up source mentioned in Wake-up Section except the PTR overflow event. If the bits [7:0] are not equal to 00H, the MCU will be woken up from the Power Down mode by the following events except WDT overflow event: <ul style="list-style-type: none"> • I/O Port wake-up • INT wake-up • Reset • The Period Timer is reached to the values specified by the PTR. |

Period Timer Register – PTR

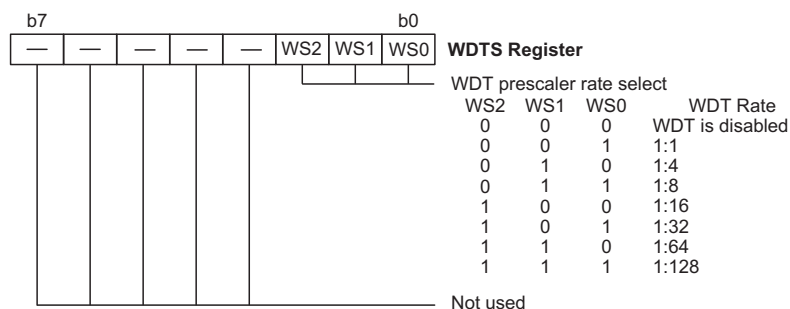

Watchdog Timer Register

DC-to-DC Converter (DC/DC) Section

This circuit is used to generate a stable 2.8V or 3.0V or 3.3V (error±5%) power voltage for whole IC and output to the IRPT. The clock of DC/DC is 140kHz. Also it can detect the battery voltage. If the battery voltage drops to 2.2V or 2.0V determined by a configuration option (error±5%), the DC/DC circuit will output a Low Voltage Detect signal LVD (2.2V/2.0V Low battery flag stored in associated flag bit of the Control Register CTLR.2) to MCU. Also there is a low voltage reset (LVR) circuit to check the DC/DC output voltage. When the DC/DC output voltage drops to 2.4V, the MCU will be reset. The LVR function is controlled by a configuration together with a software control bit named DC_ctrl in the Control Register CTLR. To enable the LVR function, the configuration option of LVR function has to be enabled and the control bit DC_ctrl must be set to 0 to enable the DC/DC circuit. If the configuration option is selected to disable the LVR function or the DC_ctrl bit is set to 1 to disable the DC/DC circuit, then the LVR function will be disabled. If the LVR function is enabled by appropriate set-

ting of the configuration option and software control bit as mentioned above, then the LVR still works even if the MCU enters into the Power Down Mode. It is recommended that the LVR function is enabled when the MCU is in the Power Down Mode.

When the DC/DC output voltage drops to 2.2V, the DC/DC can still work properly and is capable of outputting driving current with 100mA typically.

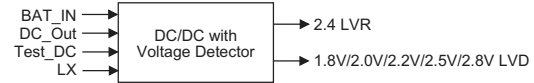

As the voltage of the Battery-in pin drops to 1.8V, the DC/DC still has the capability of outputting current with 40mA at least.

The DC/DC output signal 1.8V/2.0V/2.2V/2.5V/2.8V LVD is connected to the associated flag in Control Register (i.e. bit 2 in CTLR).

Test_DC is the internal test pin of the DC_DC.

SPI Serial Interface

The device includes one SPI Serial Interfaces. The SPI interface is a full duplex serial data link, originally designed by Motorola, which allows multiple devices connected to the same SPI bus to communicate with each other. The devices communicate using a master/slave technique where only the single master device can initiate a data transfer. A simple four line signal bus is used for all communication.

SPI Interface Communication

Four lines are used for each function. These are, SDI - Serial Data Input, SDO - Serial Data Output, SCK - Serial Clock and \overline{SCS} - Slave Select. Note that the condition of the Slave Select line is conditioned by the CSEN bit in the SBCR control register. If the CSEN bit is high then the \overline{SCS} line is active while if the bit is low then the \overline{SCS} line will be I/O mode. The accompanying timing diagram depicts the basic timing protocol of the SPI bus.

SPI Registers

There are three registers for control of the SPI Interface. These are the SBCR register which is the control register and the SBDR which is the data register and SPIR register which is the SPI mode control register. The SBCR register is used to setup the required setup parameters for the SPI bus and also used to store associated operating flags, while the SBDR register is used for data storage.

The SPIR register is used to select SPI mode, clock polarity edge selection and SPI enable or disable selection.

After Power on, the contents of the SBDR register will be in an unknown condition while the SBCR register will default to the condition below:

| CKS | M1 | M0 | SBEN | MLS | CSEN | WCOL | TRF |
|-----|----|----|------|-----|------|------|-----|
| 0 | 1 | 1 | 0 | 0 | 0 | 0 | 0 |

Note that data written to the SBDR register will only be written to the TXRX buffer, whereas data read from the SBDR register will actual be read from the register.

SPI Bus Enable/Disable

To enable the bus, the SBEN bit should be set high, then wait for data to be written to the SBDR (TXRX buffer) register. For the Master Mode, after data has been written to the SBDR (TXRX buffer) register then transmission or reception will start automatically. When all the data has been transferred, the TRF bit should be set. For the Slave Mode, when clock pulses are received on SCK, data in the TXRX buffer will be shifted out or data on SDI will be shifted in.

To Disable the SPI bus SCK, SDI, SDO, \overline{SCS} should be I/O mode.

| Bit No. | Label | R/W | Function |
|---------|--------------|-----|--|
| 0 | SPI_CPOL | R/W | 0: clock polarity falling (default falling) 1: clock polarity rising |
| 1 | SPI_MODE | R/W | 0: SPI output the data in the rising edge(polarity=1) or falling edge (polarity=0); SPI read data in the in the falling edge(polarity=1) or rising edge (polarity=0); (default) 1: SPI first output the data immediately after the SPI is enable. And SPI output the data in the falling edge(polarity=1) or rising edge (polarity=0); SPI read data in the in the rising edge(polarity=1) or falling edge (polarity=0) |
| 2 | SPI_CSEN | R/W | 0: SPI_CSEN disable, \overline{SCS} define as GPIO (default disable) 1: SPI_CSEN Enable , this bit is used to enable/disable software CSEN function |
| 3 | SPI_EN | R/W | This bit control the shared PIN (\overline{SCS} , SDI, SDO and SCK) is SPI or GPIO mode 0: I/O mode (default) 1: SPI mode |
| 7~4 | Reserved bit | R/W | Always 0 |

SPIR Register

SPI Operation

All communication is carried out using the 4-line interface for both Master or Slave Mode. The timing diagram shows the basic operation of the bus.

The CSEN bit in the SBCR register controls the \overline{SCS} line of the SPI interface. Setting this bit high, will enable the SPI interface by allowing the \overline{SCS} line to be active, which can then be used to control the SPI interface. If the CSEN bit is low, the \overline{SCS} line will be in a floating condition and can therefore not be used for control of the SPI interface. The SBEN bit in the SBCR register must also be high which will place the SDI line in a floating condition and the SDO line high. If in the Master Mode the SCK line will be either high or low depending upon the clock polarity control bit in SPIR register. If in the Slave Mode the SCK line will be in a floating condition. If SBEN is low then the bus will be disabled and \overline{SCS} , SDI, SDO and SCK will all be I/O mode.

In the Master Mode, the Master will always generate the clock signal. The clock and data transmission will be initiated after data has been written to the SBDR register. In the Slave Mode, the clock signal will be received from an external master device for both data transmission or reception. The following sequences show the order to be followed for data transfer in both Master and Slave Mode:

- Master Mode

- Step 1. Select the clock source using the CKS bit in the SBCR control register
- Step 2. Setup the M0 and M1 bits in the SBCR control register to select the Master Mode and the required Baud rate. Values of 00, 01 or 10 can be selected.
- Step 3. Setup the CSEN bit and setup the MLS bit to choose if the data is MSB or LSB first, this must be same as the Slave device.
- Step 4. Setup the SBEN bit in the SBCR control register to enable the SPI interface.
- Step 5. For write operations: write the data to the SBDR register, which will actually place the data into the TXRX buffer. Then use the SCK and \overline{SCS} lines to output the data. Goto to step 6. For read operations: the data transferred in on the SDI line will be stored in the TXRX buffer until all the data has been received at which point it will be latched into the SBDR register.
- Step 6. Check the WCOL bit, if set high then a

collision error has occurred so return to step 5. If equal to zero then go to the following step.

- Step 7. Check the TRF bit or wait for an SPI serial bus interrupt.
 - Step 8. Read data from the SBDR register.
 - Step 9. Clear TRF.
 - Step 10. Goto step 5.
- Slave Mode:
 - Step 1. The CKS bit has a don't care value in the slave mode.
 - Step 2. Setup the M0 and M1 bits to 11 to select the Slave Mode. The CKS bit is don't care.
 - Step 3. Setup the CSEN bit and setup the MLS bit to choose if the data is MSB or LSB first, this must be same as the Master device.
 - Step 4. Setup the SBEN bit in the SBCR control register to enable the SPI interface.
 - Step 5. For write operations: write data to the SBDR register, which will actually place the data into the TXRX register, then wait for the master clock and \overline{SCS} signal. After this goto Step 6. For read operations: the data transferred in on the SDI line will be stored in the TXRX buffer until all the data has been received at which point it will be latched into the SBDR register.
 - Step 6. Check the WCOL bit, if set high then a collision error has occurred so return to step 5. If equal to zero then goto the following step.
 - Step 7. Check the TRF bit or wait for an SPI serial bus interrupt.
 - Step 8. Read data from the SBDR register.
 - Step 9. Clear TRF
 - Step 10. step 5

SPI Configuration Options and Status Control

One option is to enable the operation of the WCOL, write collision bit, in the SBCR register. Some control in SPIR register. The SPI_CPOL select the clock polarity of the SCK line . The SPI_MODE select SPI data output mode.

SPI include four pins , can share I/O mode status . The status control combine with four bits for SPIR and SBCR register. Include SPI_CSEN , SPI_EN for SPIR register and CSEN ,SBEN for SBCR register.

| SPIR(22H) | | SBCR(23H) | | I/O Status | | Note |
|-----------|----------|-----------|------|------------|-----------------------|--|
| SPI_EN | SPI_CSEN | SBEN | CSEN | SPI | \overline{SCS} | |
| 0 | x | x | x | I/O mode | I/O mode | |
| 1 | x | 0 | x | I/O mode | I/O mode | |
| 1 | 0 | 1 | x | SPI mode | I/O mode | \overline{SCS} not Floating |
| 1 | 1 | 1 | 0 | SPI mode | I/O mode | \overline{SCS} not Floating |
| 1 | 1 | 1 | 1 | SPI mode | \overline{SCS} mode | The SPI enable, \overline{SCS} , SDI, SDO, SCK the internal Pull-high function is invalid. |

Note: X: don't care

Error Detection

The WCOL bit in the SBCR register is provided to indicate errors during data transfer. The bit is set by the Serial Interface but must be cleared by the application program. This bit indicates a data collision has occurred which happens if a write to the SBDR register takes place during a data transfer operation and will prevent the write operation from continuing. The bit will be set high by the Serial Interface but has to be cleared by the user application program. The overall function of the

WCOL bit can be disabled or enabled by a configuration option.

Programming Considerations

When the device is placed into the Power Down Mode note that data reception and transmission will continue. The TRF bit is used to generate an interrupt when the data has been transferred or received.

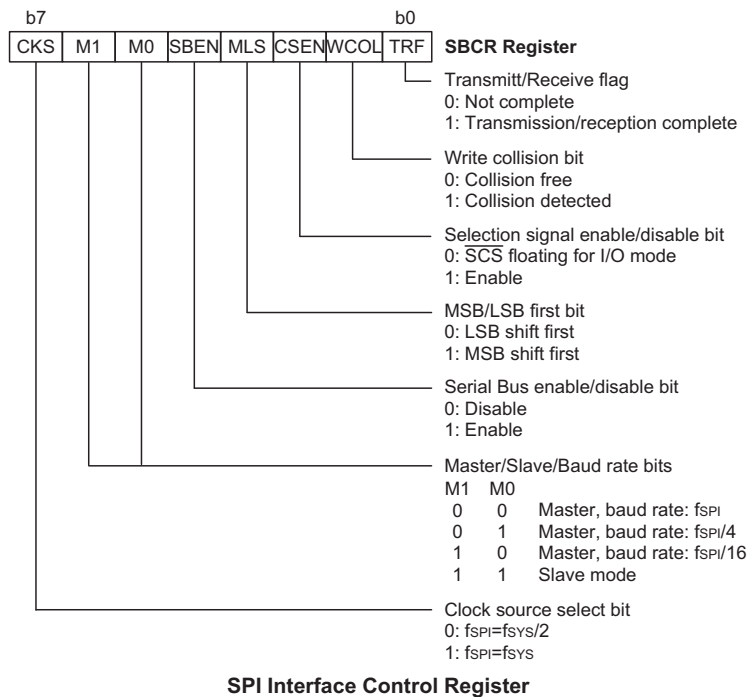

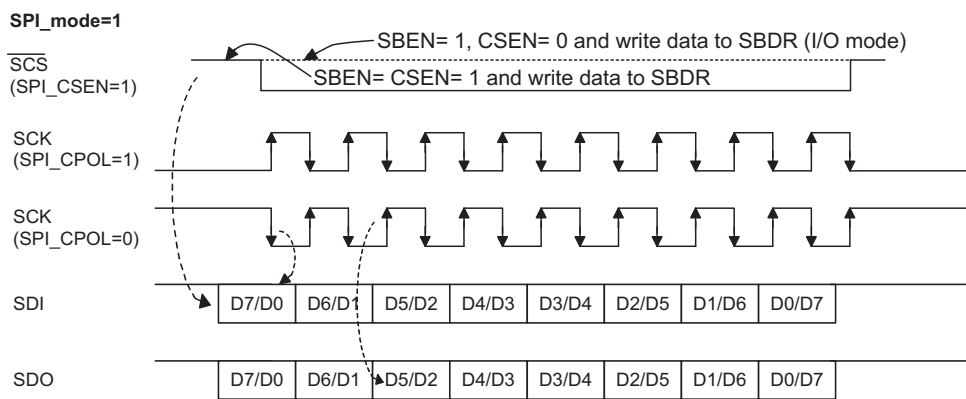
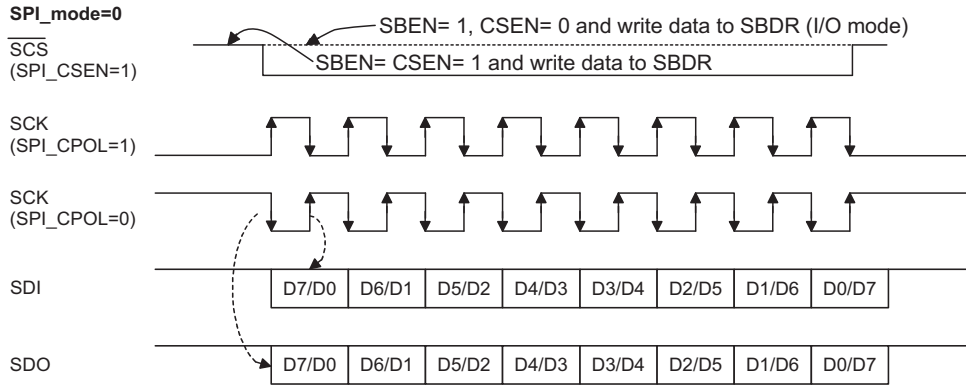

SPI Bus Timing

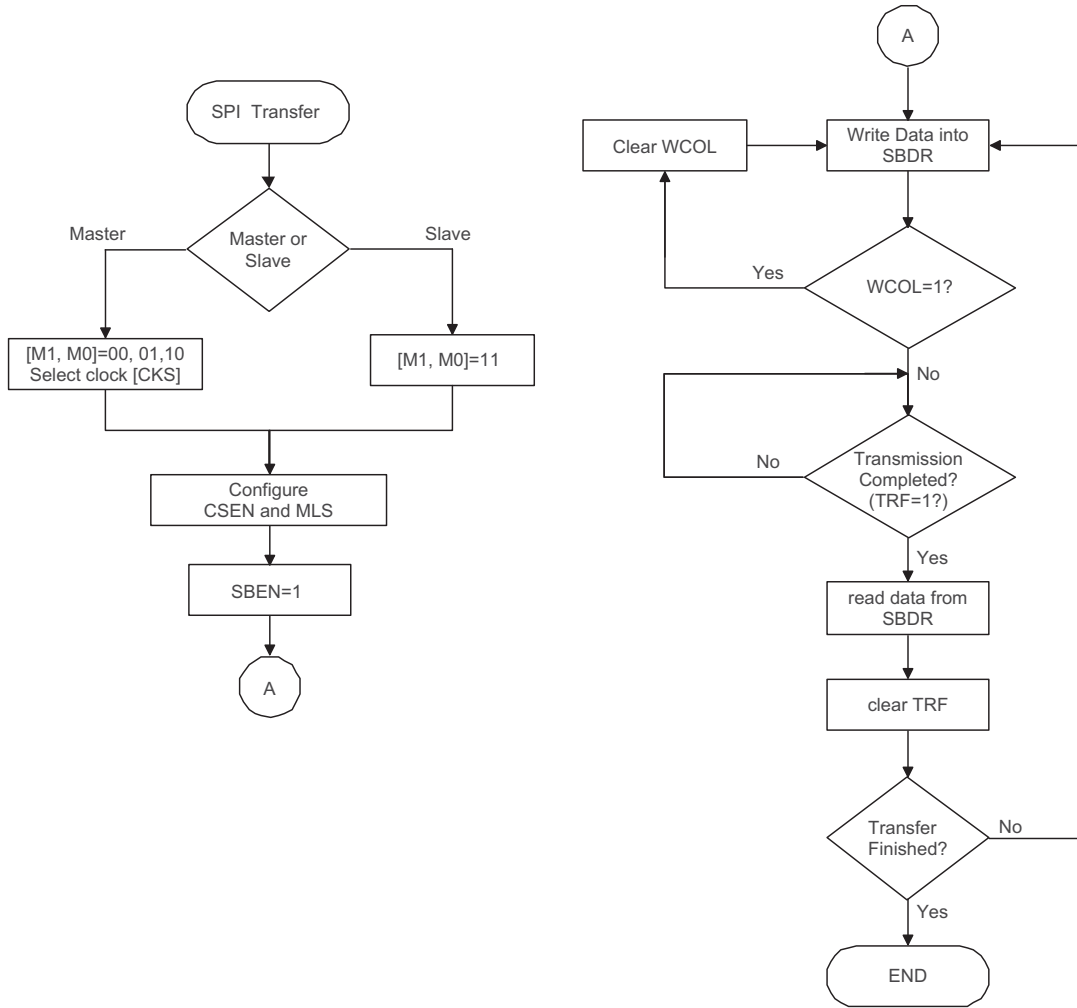

SPI Transfer Control Flowchart

Configuration Options

| No. | Options |
|-----|--|
| 1 | PA0~7 Pull-high by bit: Pull-high or non-pull-high |
| 2 | PA wake-up by bit, :Wake-up or non-wake-up |
| 3 | PB Pull-high by nibble : Pull-high or non-pull-high |
| 4 | PC Pull-high by nibble : Pull-high or non-pull-high |
| 5 | SPI_WCOL enable/disable (default) |
| 6 | Output slew enable 100ns or 200ns |
| 7 | TBHP function (enable /disable) |
| 8 | DC_DC output option:2.8V,3.0V,3.3V |
| 9 | LVR enable/disable (default disable) |
| 10 | WDT clock source : enable, disable for normal mode |
| 11 | PB wake-up by bit, Wake-up or non-wake-up |
| 12 | PC wake-up by bit, Wake-up or non-wake-up |
| 13 | PC output type CMOS/NMOS |
| 14 | PB0 output type CMOS/NMOS |
| 15 | PD pull-high by nibble: pull-high or non-pull-high (*) |
| 16 | PE pull-high by nibble: pull-high or non-pull-high (*) |
| 17 | PD wake-up by nibble: wake-up or non-wake-up (*) |
| 18 | PE wake-up by nibble: wake-up or non-wake-up (*) |

Note: For HT82K75R, there are additional configuration options as the asterisk marks shown.

Application Circuits

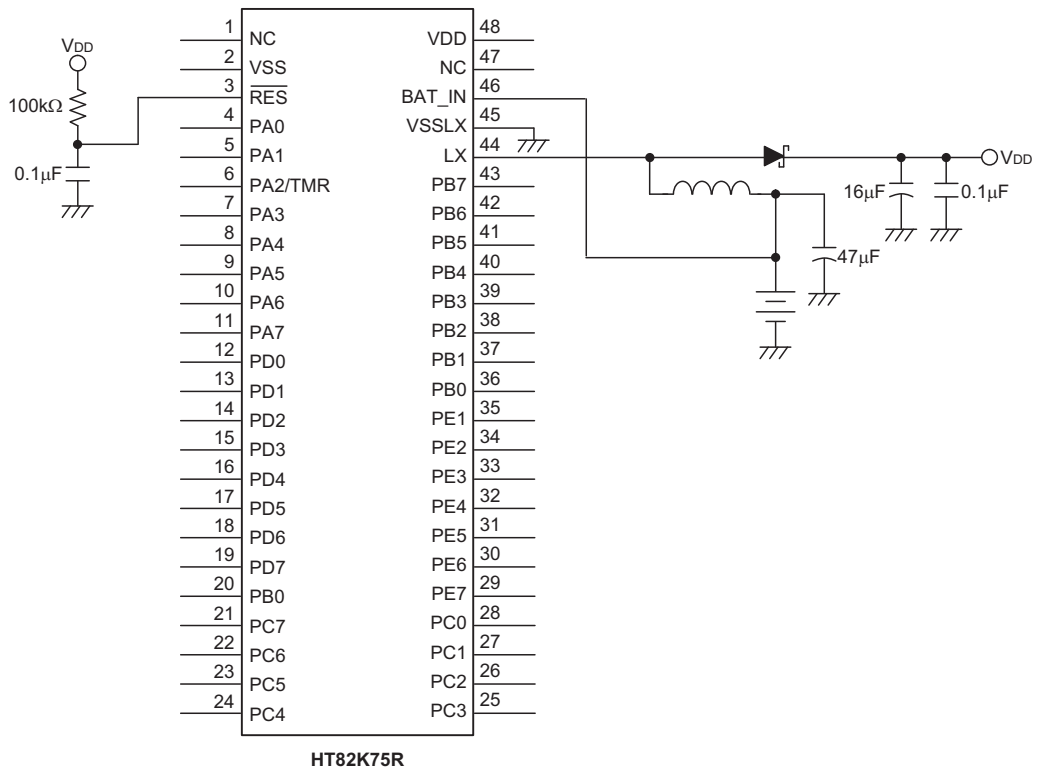
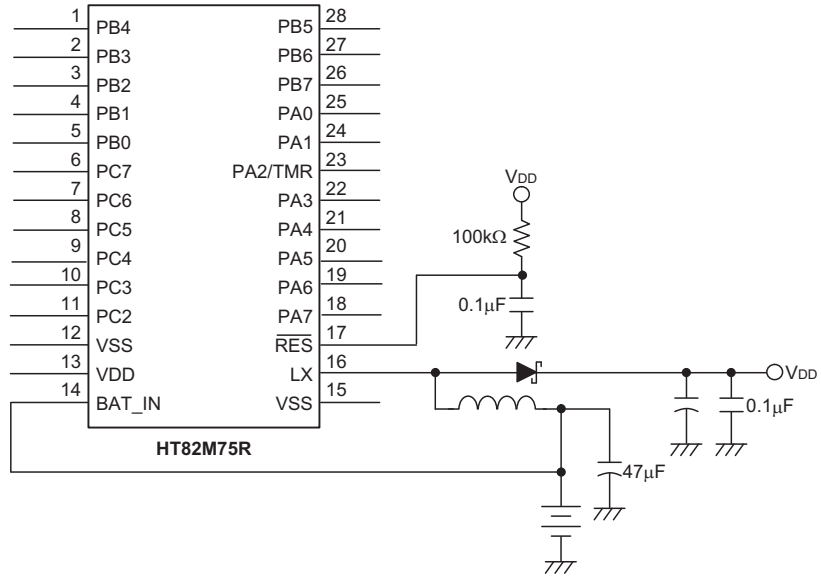

EEPROM Data Memory

EEPROM Memory Features

- 1K capacity organized into 128×8
- Accessible using two I²C lines
- Device address: 0×1010000B followed with a read/write operation selection bit
- Device Operations:
 - Byte Write Operation
 - Current Address Read Operation
 - Random Address Read Operation
 - Sequential Address Read Operation

EEPROM Memory Overview

An area of EEPROM, which stands for Electrically Erasable Programmable Read Only Memory, is contained within the device. This type of memory is non-volatile with data retention even after power is removed and is

useful for storing information such as product identification numbers, calibration values, user data, system setup data, etc.

Block Diagram

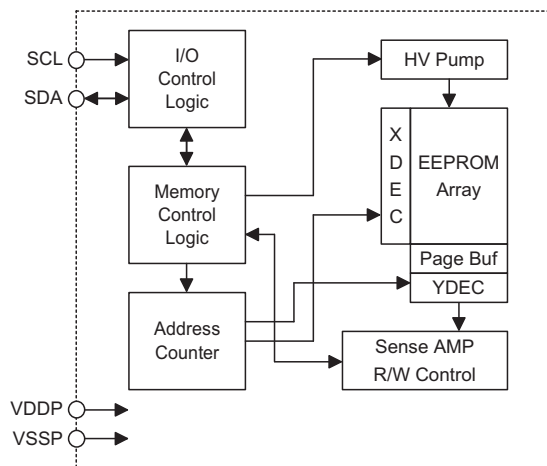

Pin Assignment

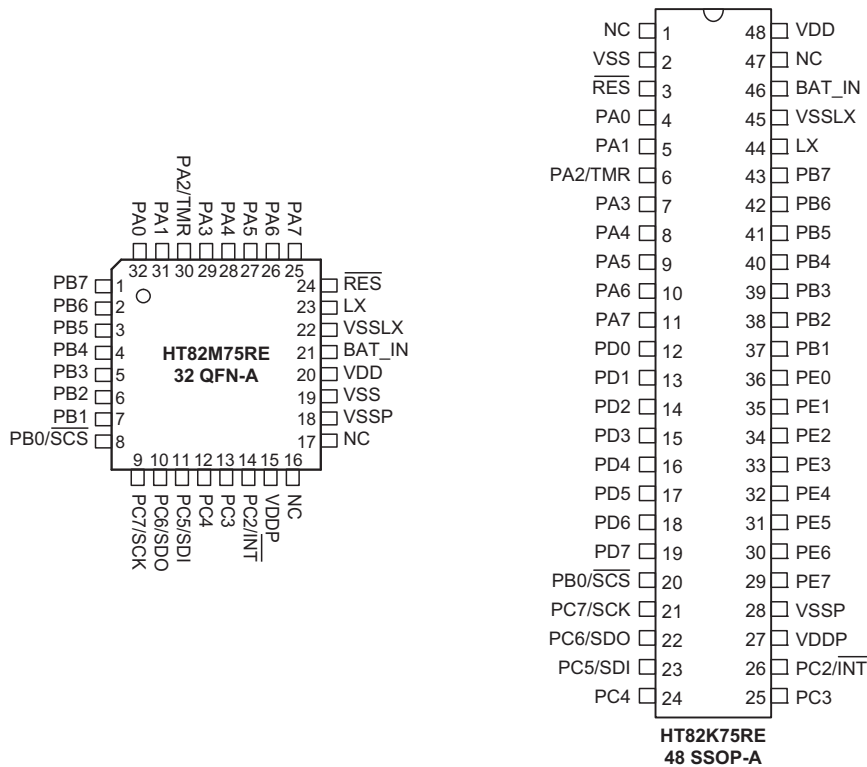

EEPROM Memory Pin Description

| Pin Name | Type | Description |
|----------|------|---|
| VDDP | — | External Positive power supply for EEPROM Memory |
| VSSP | — | External Negative power supply for EEPROM Memory, ground |
| SDA | I/O | Internal Serial data input/output signal Internal connected with MCU I/O line. |
| SCL | I | Serial clock input signal Internal connected with MCU I/O line. |
| NC | — | Implies that the pin is "Not Connected" and can therefore not be used. |

Note: The pin descriptions for all external pins with the exception of the EEPROM VDDP and VSSP pins are described in the preceding MCU section.

VDDP and VSSP should be externally connected to the MCU power supply named VDD and VSS respectively.

The SDA and SCL lines here are internal connected to the MCU I/O pins PC0 and PC1 respectively for these devices.

Absolute Maximum Ratings

| | | | |
|----------------------|--------------------------------|-----------------------------|----------------------------------|
| Supply Voltage | $V_{SS}-0.3V$ to $V_{SS}+6.0V$ | Storage Temperature | $-50^{\circ}C$ to $125^{\circ}C$ |
| Input Voltage | $V_{SS}-0.3V$ to $V_{CC}+0.3V$ | Operating Temperature | $-40^{\circ}C$ to $85^{\circ}C$ |

Note: These are stress ratings only. Stresses exceeding the range specified under "Absolute Maximum Ratings" may cause substantial damage to the device. Functional operation of this device at other conditions beyond those listed in the specification is not implied and prolonged exposure to extreme conditions may affect device reliability.

D.C. Characteristics

$T_a = -40^{\circ}C \sim 85^{\circ}C$

| Symbol | Parameter | Test Conditions | | Min. | Typ. | Max. | Unit |
|-------------|-------------------|-----------------|------------------------|------|------|------|---------|
| | | V_{CC} | Conditions | | | | |
| I_{CC1}^* | Operating Current | 3V | Read at 100kHz | — | — | 1 | mA |
| I_{CC2}^* | Operating Current | 3V | Write at 100kHz | — | — | 3 | mA |
| I_{STB}^* | Standby Current | 3V | $V_{IN}=0$ or V_{CC} | — | — | 3 | μA |

Note: "*" The operating current I_{CC1} and I_{CC2} listed here are the additional currents consumed when the EEPROM Memory operates in Read Operation and Write Operation respectively. If the EEPROM is operating, the I_{CC1} or I_{CC2} should be added to calculate the relevant operating current of the device for different conditions. To calculate the standby current for the whole device, the standby current shown above should also be taken into account.

A.C. Characteristics

$T_a = -40^{\circ}C \sim 85^{\circ}C$

| Symbol | Parameter | Remark | Standard Mode* | | Unit |
|--------------|---|--|----------------|------|------|
| | | | Min. | Max. | |
| f_{SK} | SCL Clock Frequency | — | — | 100 | kHz |
| t_{HIGH} | Clock High Time | — | 4000 | — | ns |
| t_{LOW} | Clock Low Time | — | 4700 | — | ns |
| t_r | SDA and SCL Rise Time | Note | — | 1000 | ns |
| t_f | SDA and SCL Fall Time | Note | — | 300 | ns |
| $t_{HD:STA}$ | START Condition Hold Time | After this period the first clock pulse is generated | 4000 | — | ns |
| $t_{SU:STA}$ | START Condition Setup Time | Only relevant for repeated START condition | 4000 | — | ns |
| $t_{HD:DAT}$ | Data Input Hold Time | — | 0 | — | ns |
| $t_{SU:DAT}$ | Data Input Setup Time | — | 200 | — | ns |
| $t_{SU:STO}$ | STOP Condition Setup Time | — | 4000 | — | ns |
| t_{AA} | Output Valid from Clock | — | — | 3500 | ns |
| t_{BUF} | Bus Free Time | Time in which the bus must be free before a new transmission can start | 4700 | — | ns |
| t_{SP} | Input Filter Time Constant (SDA and SCL Pins) | Noise suppression time | — | 100 | ns |
| t_{WR} | Write Cycle Time | — | — | 5 | ms |

Note: These parameters are periodically sampled but not 100% tested

* The standard mode means $V_{CC}=2.2V$ to $3.6V$

For relative timing, refer to timing diagrams

EEPROM Data Memory Functional Description

The embedded EEPROM Data Memory is an I2C type device and therefore operates using a two wire serial bus. It has a capacity is 1K organized into a structure of 128 8-bit words and contains the information or data important for user.

EEPROM Data Memory Internal Connection

In addition to the pins described above there are other MCU to EEPROM Data Memory interconnecting lines that are described in the above EEPROM Pin Description table. Note that the SDA and SCL lines are internal connected to the MCU I/O pins respectively and are not bonded to external pins.

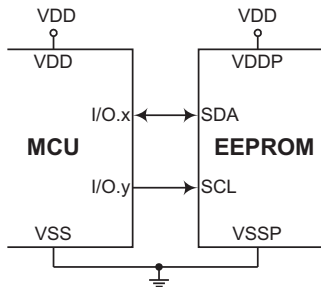

Dual VDD/Single VSS Power Supply
MCU to EEPROM Internal Connection

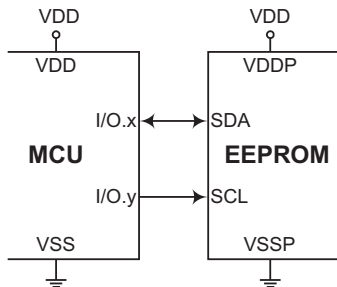

Dual VDD / Dual VSS Power Supply
MCU to EEPROM Internal Connection

Accessing the EEPROM Data Memory

The two I2C lines are the Serial Clock line, SCL, and the Serial Data line SDA. The SDA and SCL pins are internal connected to the host MCU I/O pins. Normal I/O control software instructions are used to control the reading and writing operations on the EEPROM Data Memory.

- Serial data - SDA
The SDA line is the bidirectional EEPROM serial data line which is controlled by the host MCU I/O pin. The host MCU should configure this I/O pin as input or output dynamically opposite to the data direction of the EEPROM. The SDA line is an internal line and not connected to an output pin.

- Serial clock - SCL
The SCL line is the EEPROM serial clock input line which is controlled by the host MCU I/O pin. The host MCU should configure this I/O pin connected to the SCL line as output pin. The SCL line is an internal line and not connected to an output pin. The SCL input clocks data into the EEPROM on its positive edge and clocks data out of the EEPROM on its negative edge.
- Clock and data transition
Data transfer may be initiated only when the bus is not busy. During data transfer, the data line must remain stable whenever the clock line is high. Changes in the data line while the clock line is high will be interpreted as a START or STOP condition.
- Start condition
A high-to-low transition of SDA with SCL high will be interpreted as a start condition which must precede any other command - refer to the Start and Stop Definition Timing diagram.
- Stop condition
A low-to-high transition of SDA with SCL high will be interpreted as a stop condition. After a read sequence the stop command will place the EEPROM in a standby power mode - refer to Start and Stop Definition Timing Diagram.
- Acknowledge
All addresses and data words are serially transmitted to and from the EEPROM in 8-bit words. The EEPROM sends a zero to acknowledge that it has received each word. This happens during the ninth clock cycle.

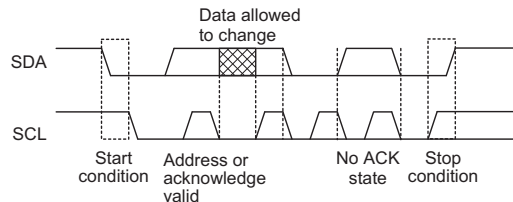

Start and Stop Definition Timing Diagram

Device Addressing

All EEPROM devices require an 8-bit device address word following a start condition to enable the EEPROM for read or write operations. The device address word consist of a mandatory one, zero sequence for the first four most significant bits. Refer to the diagram showing the Device Address. This is common to all the EEPROM devices. The next three bits are all zero bits.

The 8th bit of device address is the read/write operation select bit. A read operation is initiated if this bit is high and a write operation is initiated if this bit is low.

If the comparison of the device address is successful then the EEPROM will output a zero as an ACK bit. If not, the EEPROM will return to a standby state.

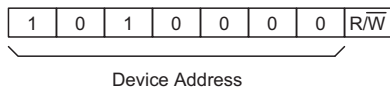

Device Operations

- Byte Write**
 A write operation requires an 8-bit data word address following the device address word and acknowledgment. Upon receipt of this address, the EEPROM will again respond with a zero and then clock in the first 8-bit data word. After receiving the 8-bit data word, the EEPROM will output a zero and the addressing device must terminate the write sequence with a stop condition. At this time the EEPROM enters an internally-timed write cycle to the non-volatile memory. All inputs are disabled during this write cycle and EEPROM will not respond until the write cycle is completed.
- Acknowledge polling**
 To maximize bus throughput, one technique is to allow the master to poll for an acknowledge signal after the start condition and the control byte for a write command have been sent. If the device is still busy implementing its write cycle, then no ACK will be returned. The master can send the next read/write command when the ACK signal has finally been received.

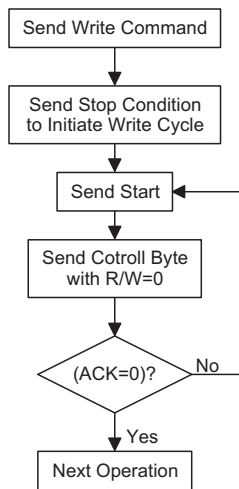

Acknowledge Polling Flow

- Read operations**
 The data EEPROM supports three read operations, namely, current address read, random address read and sequential read. During read operation execution, the read/write select bit should be set to 1.
- Current address read**
 The internal data word address counter maintains the last address accessed during the last read or write operation, incremented by one. This address stays valid between operations as long as the EEPROM power is maintained. The address will roll over during a read from the last byte of the last memory page to the first byte of the first page. Once the device address with the read/write select bit set to one is clocked in and acknowledged by the EEPROM, the current address data word is serially clocked out. The microcontroller should respond a No ACK - High - signal and a following stop condition.
- Random read**
 A random read requires a dummy byte write sequence to load in the data word address which is then clocked in and acknowledged by the EEPROM. The microcontroller must then generate another start condition. The microcontroller now initiates a current address read by sending a device address with the read/write select bit high. The EEPROM acknowledges the device address and serially clocks out the data word. The microcontroller should respond with a No ACK signal - high - followed by a stop condition.
- Sequential read**
 Sequential reads are initiated by either a current address read or a random address read. After the microcontroller receives a data word, it responds with an acknowledgment. As long as the EEPROM receives an acknowledgment, it will continue to increment the data word address and serially clock out sequential data words. When the memory address limit is reached, the data word address will roll over and the sequential read continues. The sequential read operation is terminated when the microcontroller responds with a No ACK signal - high - followed by a stop condition.

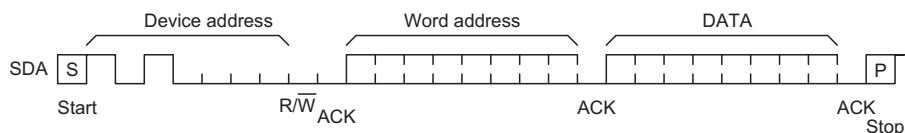

Byte Write Timing

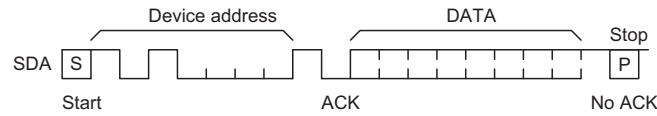

Current Read Timing

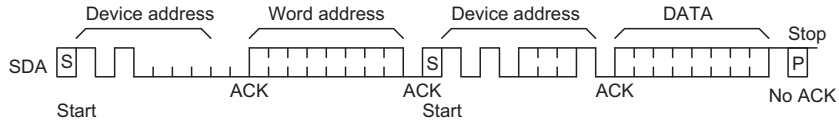

Random Read Timing

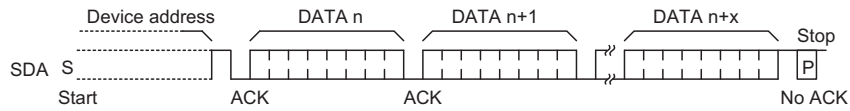

Sequential Read Timing

Timing Diagrams

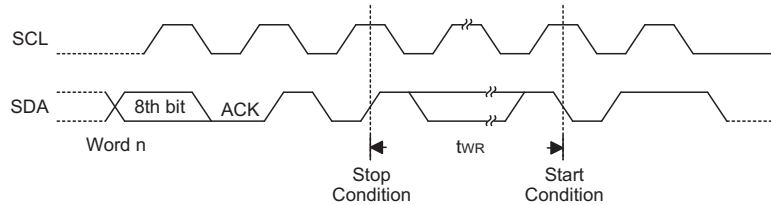
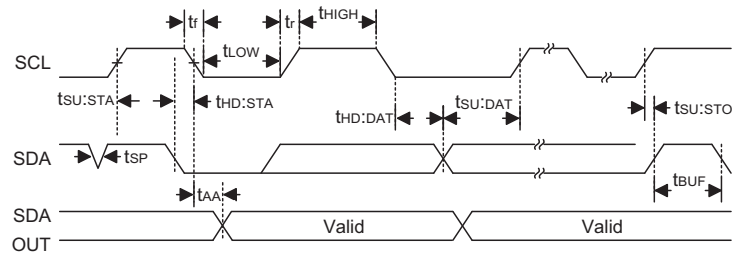

Note: The write cycle time t_{WR} is the time from a valid stop condition of a write sequence to the end of the valid start condition of sequential command.

Application Circuits with EEPROM Data Memory

For 32-pin QFN Application Circuit

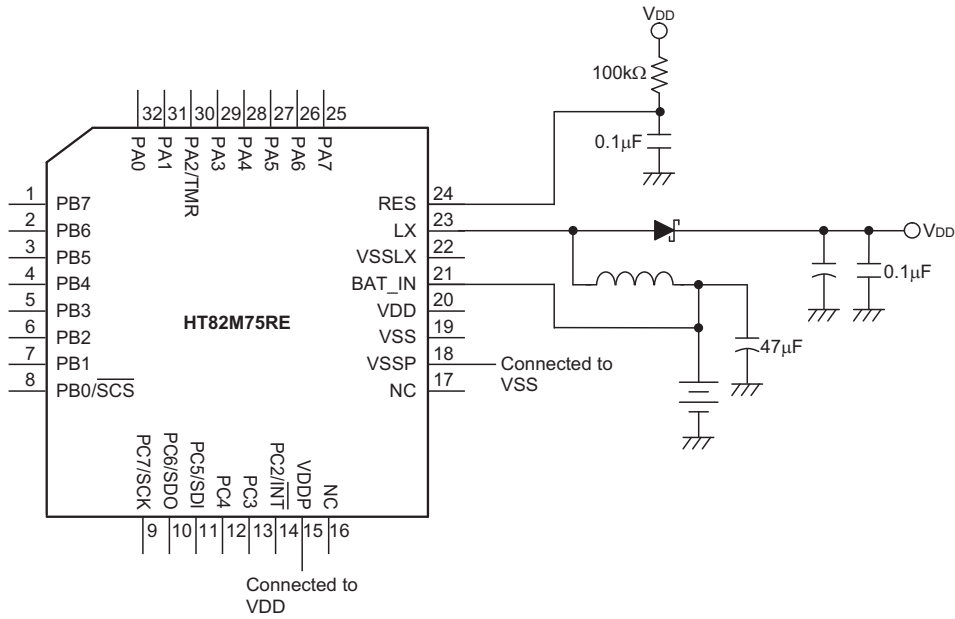

For 48-pin SSOP Application Circuit

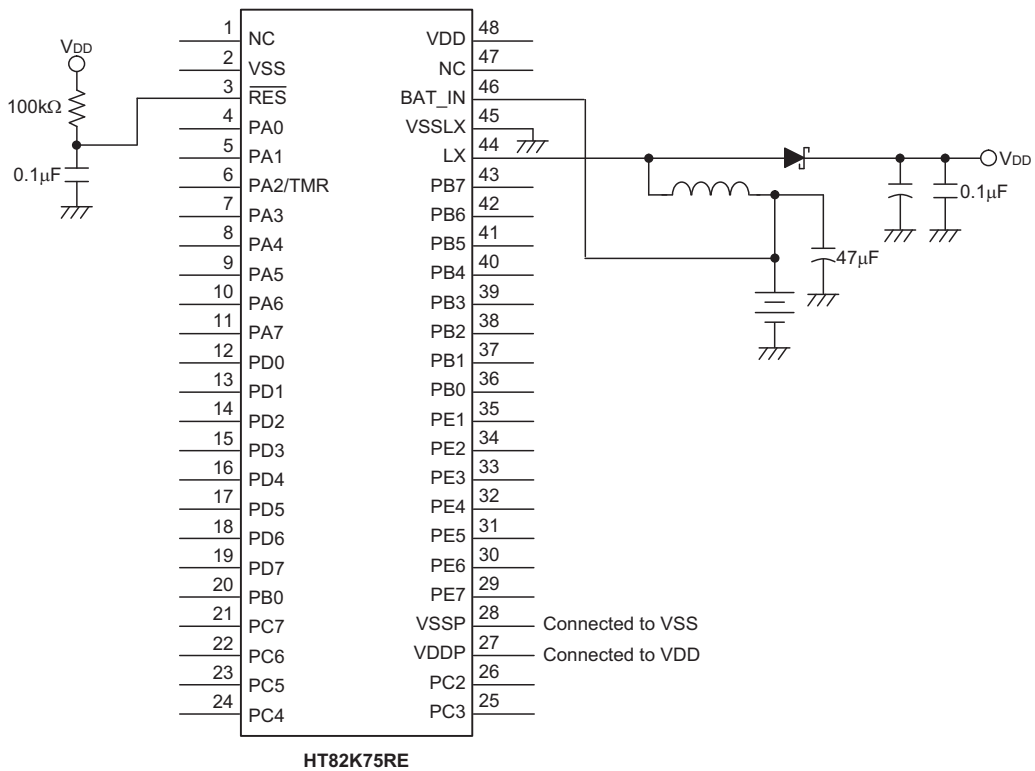

RF Transceiver

RF Transceiver Features

RF/Analog Circuit Features

- ISM band 2.400GHz~2.495GHz operation
- -90dBm/-80dBm sensitivity @ 250k/1M bps (Packet error rate under 0.1%)
- 3dBm maximum input level
- -3dBm~0dBm typical output power
- Differential RF input/output and integrated TX/RX switch
- Integrated low phase noise VCO, frequency synthesizer and PLL loop filter
- Integrated 32MHz oscillator drive
- Digital VCO and filter calibration
- 18mA in RX and 15mA in TX mode
- 2.4μA deep sleep mode, 0.1μA power down
- 1M bps turbo mode supported
- PLL lock-on time less than 130μs

MAC/Baseband Features

- Automatic ACK response and FCS check
- 62-byte TX FIFO
- Dual 64-byte RX FIFOs
- Various power saving modes
- Simple four-wire SPI interface

RF Transceiver Applications

- Home/Building/Factory Automation
- PC Peripheral
- RF Remote Controller
- Consumer Electronics
- 2-way Medium-Data-Rate Applications

RF Transceiver Overview

The device contains a 2.4 GHz RF transceiver with a Baseband/MAC block. The RF transceiver can be controlled by the MCU for low data rate applications such as consumer electronics, PC peripherals, toys, industrial

automations, etc. For medium data rate applications like wireless voice and image transmission, the RF transceiver provides 1M bps turbo mode.

RF Transceiver Block Diagram

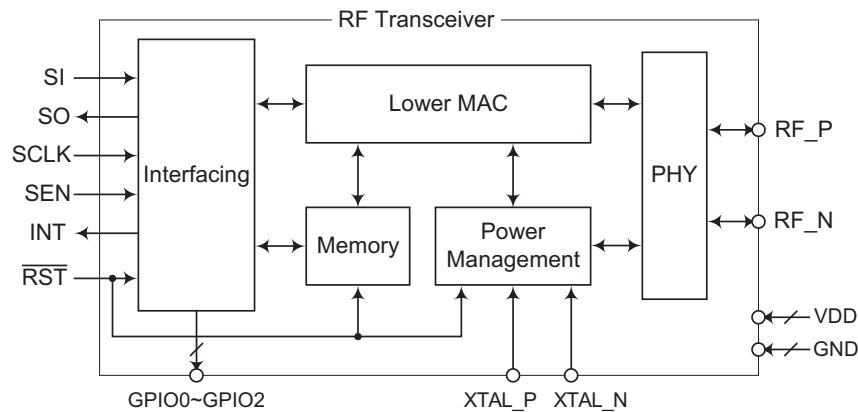

Pin Assignment

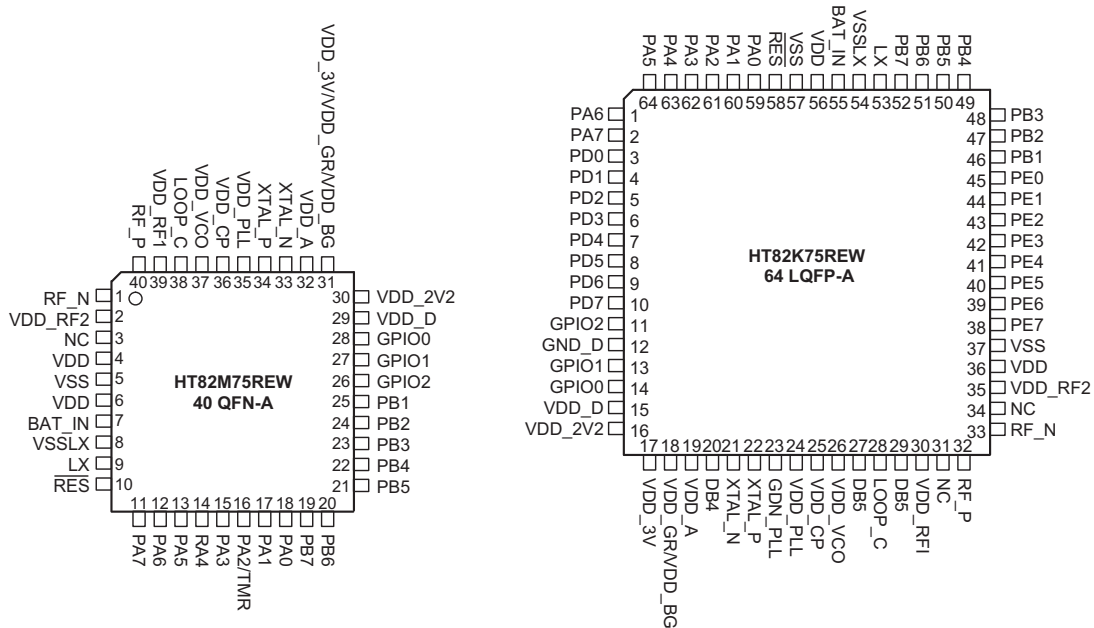

RF Transceiver Pin Description

| Pin Name | Type | Description |
|----------|------|---|
| RF_P | I/O | External Differential RF input/output (+) |
| RF_N | I/O | External Differential RF input/output (-) |
| VDD_RF1 | I | External RF transceiver power supply ⁽¹⁾ |
| VDD_RF2 | I | External RF transceiver power supply ⁽¹⁾ |
| GPIO0 | I/O | External General Purpose digital I/O It is also used as an external TX/RX switch control |
| GPIO1 | I/O | External General Purpose digital I/O It is also used as an external Power Amplifier (P.A.) enable control. |
| GPIO2 | I/O | External General Purpose digital I/O It is also used as an external Power Amplifier (P.A.) enable control. |
| VDD_D | I | External RF transceiver digital circuit power supply (+) |
| GND_D | I | External RF transceiver digital circuit power supply (-) |
| VDD_2V2 | O | External RF transceiver DC-DC output voltage It cannot be used. |
| VDD_3V | I | External RF transceiver 3V input for a DC-DC regulator |
| GND_GR | — | External RF transceiver Guard-Ring ground |
| VDD_A | I | External RF transceiver power supply for analog circuits ⁽¹⁾ |
| XTAL_P | I | External RF transceiver 32MHz Crystal input (+) |
| XTAL_N | I | External RF transceiver 32MHz Crystal input (-) |
| VDD_PLL | I | External RF transceiver PLL power supply ⁽¹⁾ |
| VDD_CP | I | External RF transceiver Charge pump power supply ⁽¹⁾ |
| VDD_VCO | I | External RF transceiver Voltage-controlled oscillator power supply ⁽¹⁾ |
| LOOP_C | I/O | External RF transceiver PLL loop filter external capacitor It is connected to the external 47pF capacitor. |

| Pin Name | Type | Description |
|-------------------------|------|---|
| VDD_GR | I | External RF transceiver Guard-Ring power supply ⁽¹⁾ |
| VDD_BG | O | External RF transceiver Bandgap power supply ⁽¹⁾ |
| DB4 | I | External Test pin It is connected to ground. |
| DB5 | I | External Test pin It is connected to ground. |
| SI | I | Internal RF Transceiver Slave SPI Serial Data Input Signal Internally connected to the MCU Master SPI SDO output signal |
| SO | O | Internal RF Transceiver Slave SPI Serial Data Output Signal Internally connected to the MCU Master SPI SDI input signal |
| SCLK | I | Internal RF Transceiver Slave SPI Serial Clock Input Signal Internally connected to the MCU Master SPI SCK output signal |
| SEN | I | Internal RF Transceiver Slave SPI Serial interface Enable Input Signal Internally connected to the MCU Master SPI SCS output signal |
| $\overline{\text{INT}}$ | I | Internal RF Transceiver Interrupt Output Signal Internally connected to the MCU INT input signal |
| $\overline{\text{RST}}$ | I | Internal RF Transceiver global hardware reset input signal, active low. Internally connected to the MCU I/O pin configured as output type. |
| NC | — | Implies that the pin is "Not Connected" and can therefore not be used. |

Notes: (1) Connecting bypass capacitor(s) as close to the pin as possible.

(2) The pin descriptions for all external pins except the RF Transceiver pins listed in the above table are described in the preceding MCU section.

(3) The $\overline{\text{INT}}$ and $\overline{\text{RST}}$ lines are internally connected to the MCU I/O pins PC2 and PC3 respectively for the HT82M75REW and HT82K75REW devices.

RF Transceiver D.C. Characteristics

$V_{DD}=3V$, $T_a=25^\circ\text{C}$

| Symbol | Test Conditions | Min. | Typ. | Max. | Unit |
|-----------|--|------|------|------|---------------|
| I_{TX} | RF Transceiver TX Active. At 0 dBm output power | — | 21 | 30 | mA |
| I_{RX} | RF Transceiver RX Active in Normal Mode (250 Kbps) | — | 19 | 28 | mA |
| | RF Transceiver RX Active in Turbo Mode (1M bps) | — | 21 | 30 | mA |
| I_{STB} | RF Transceiver in STANDBY mode. Partial 32MHz clock and Sleep clock remains active. RF/MAC/BB, system clock shutdown. | — | 60 | 80 | μA |
| I_{DS} | RF Transceiver in DEEP_SLEEP mode. Power to digital circuit remains active to retain Registers and FIFOs. All the other power is shutdown. | — | 3.2 | 10.0 | μA |
| I_{PD} | RF Transceiver in POWER_DOWN mode. Minimum wake-up circuit remains active. All power is shutdown. Register and FIFO data are not retained. | — | 0.6 | 2.0 | μA |

Note: "***" The operating current I_{TX} or I_{RX} listed here is the additional current consumed when the RF Transceiver operates in Active TX mode or Active RX mode. If the RF Transceiver is active, either I_{TX} or I_{RX} should be added to calculate the relevant operating current of the device for different operating mode. To calculate the standby current for the whole device, the standby current shown above including I_{STB} , I_{DS} and I_{PD} should be taken into account for different Power Saving Mode.

RF Transceiver A.C. Characteristics
 $V_{DD}=3V$, $T_a=25^{\circ}C$, LO frequency=2.445GHz, DC-DC Off

Receiver

| Parameters | Test Conditions | Min. | Typ. | Max. | Unit | |
|--------------------------------------|---|---------|-----------|-------|------------|-----|
| RF Input Frequency | — | 2.400 | — | 2.495 | GHz | |
| RF Sensitivity | At antenna input with O-QPSK signal, PER \leq 0.1% | 250Kbps | — | -90 | — | dBm |
| | | 1 Mbps | — | -80 | — | dBm |
| Maximum RF Input | — | — | 5 | — | dBm | |
| Adjacent Channel Rejection | @ ± 5 MHz, 250Kbps (-82dBm + 20 dB = -62dBm) | — | 20 -62 | — | dBc dBm | |
| Alternative Channel Rejection | @ ± 10 MHz, 250Kbps (-82dBm + 40 dB = -42dBm) | — | 40 -42 | — | dBc dBm | |
| LO Leakage | Measured at the balun matching the network with the input frequency at 2.4~2.5GHz | — | -60 | — | dBm | |
| Noise figure (Including matching) | — | — | 8 | — | dB | |

Transmitter
 $V_{DD}=3V$, $T_a=25^{\circ}C$, LO frequency=2.445GHz, 250 Kbps, DC-DC Off

| Parameters | Test Conditions | Min. | Typ. | Max. | Unit |
|------------------------------------|---|-------|------|---------|------|
| RF carrier frequency | — | 2.400 | — | 2.495 | GHz |
| Maximum RF output power | At 0 dBm output power setting | -3 | 0 | — | dBm |
| RF output power Accuracy | — | — | — | ± 4 | dBm |
| RF output power control range | — | — | 36 | — | dB |
| TX gain control resolution | — | 0.1 | — | 0.5 | dB |
| Carrier suppression | — | — | -30 | — | dBc |
| TX spectrum mask for O-QPSK signal | Offset frequency > 3.5 MHz At 0 dBm output power | — | — | -30 | dBm |
| | | — | — | -20 | dBc |
| TX EVM | — | — | 30 | — | % |

Synthesizer
 $V_{DD}=3V$, $T_a=25^{\circ}C$, LO frequency=2.445GHz, 250 Kbps, DC-DC Off

| Parameters | Test Conditions | Min. | Typ. | Max. | Unit |
|----------------------------|-----------------|------|------|------|---------|
| PLL Stable Time | — | — | 130 | — | μs |
| PLL Programming resolution | — | — | 1 | — | MHz |

RF Transceiver Power-on and Reset Characteristics

The RF Transceiver has built-in power-on reset (POR) circuit which automatically resets all digital registers when the power is turned on. The 32MHz oscillator circuit starts to lock frequency of the right clock after power-on. The whole process takes 3ms for a clock circuit to become stable and completes the power-on reset. It is highly recommended that the user waits at least 3ms before starting to access the RF Transceiver.

The RF Transceiver hardware reset signal (warm start) named \overline{RST} is controlled by MCU I/O pin and internally pulled high with 33k Ω resistor connected to VCC within the RF Transceiver. The RF Transceiver will hold in reset state around 20 μ s after \overline{RST} signal is released from the low state.

RF Transceiver Crystal Parameter Specifications

The RF Transceiver utilizes external 32MHz crystal to generate the oscillation for RF Transceiver input clock. The associated pins are XTAL_P and XTAL_N. The table below lists the parameters of the crystal oscillator used in the RF Transceiver. To operate the RF Transceiver properly, user has to select the crystal which meets the following requirements.

| Parameters | Min. | Typ. | Max. | Unit |
|-------------------|------|------|------|---------|
| Crystal Frequency | | 32 | — | MHz |
| Frequency Offset | -40 | — | 40 | ppm |
| Load Capacitance | — | — | 10 | pF |
| Recovery Time | — | — | 180 | μ s |

32 MHz crystal oscillator recovery time highly depends on the shunt capacitance of 32 MHz crystal. The lower shunt capacitance value makes the recovery time shorter. This recovery time 180 μ s is measured with 32 MHz crystal by NDK NX3225SA.

RF Transceiver Functional Description

The RF transceiver integrates receiver, transmitter, voltage-controlled oscillator (VCO), and phase-locked loop (PLL). It uses advanced radio architecture to minimize the external component count and the power consumption. The Baseband/MAC block provides the hardware architecture for both MAC and PHY layers. It mainly

consists of TX/RX control and digital signal processing module. Interconnection between the MCU and the RF Transceiver is implemented by internally connecting the MCU Master SPI interface to the RF Transceiver Slave SPI interface. All data transmissions and receptions between MCU and RF Transceiver including RF Transceiver commands are conducted along this interconnected SPI interface. The RF Transceiver function control is executed by the MCU using its SPI Master serial interface. The RF Transceiver contains its own independent interrupt which can be used to indicate when a wake-up event occurs, an available packet reception occurs or when a packet transmission has successfully terminated or retransmission is timed out.

RF Transceiver Internal Connection

In addition to the RF Transceiver external pins described above there are other MCU to RF Transceiver interconnecting lines that are described in the above RF Transceiver Pin Description table. Note that these lines are internal to the device and are not bonded to external pins.

The RF Transceiver is composed of several functional blocks named Interfacing block, Lower MAC block, Memory block, Power Management block and PHY block. The detailed functions of the functional blocks are described in the following sections.

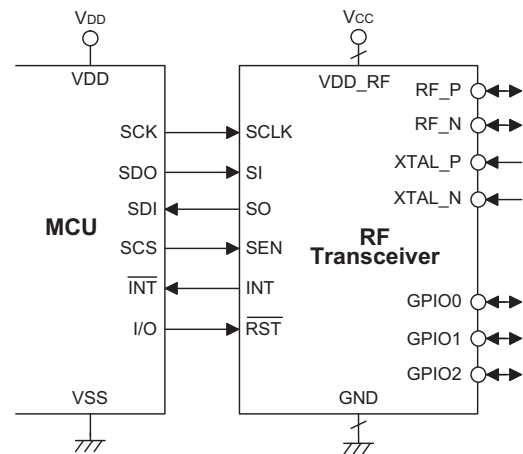

MCU to RF Transceiver Internal Connection

RF Transceiver PHY Block

The key features and the block diagram of the PHY layer in RF Transceiver are listed as below.

Operating frequency range is from 2400MHz to 2495MHz.

It uses Offset QPSK (OQPSK) modulation to transmit data at 250k/1M bps.

Direct Sequence Spreading Spectrum (DSSS) is used in baseband algorithm to increase the SNR.

The RF Transceiver uses a fractional-N Phase-Locked Loop (PLL) as frequency synthesizer. Therefore, 1MHz channel spacing is supported and any integer carrier frequency between 2400MHz to 2495MHz can be used. The loop filters of PLL are integrated into the RF Transceiver except one external capacitor which should be connected between the PLL loop filter external pin and the ground. In order to keep the PLL stable, the board layout around the PLL loop filter external capacitor pin should be carefully designed to avoid EMI. The recommended value of this external capacitor is 47pF.

Under 1M bps turbo mode, user can use the same program settings of MAC and all MAC functions are remained the same. Compare with 250k bps mode, in 1M bps mode, signal bandwidth is extended to 8MHz.

The packet includes a 6 bytes PHY header and a 7~63 bytes PHY payload. The 6 bytes PHY header includes 4 bytes of preamble, 1 byte of start-of-frame delimiter (SFD) and 1 byte of payload length. Preamble and SFD are used for receiver packet detection and synchronization. The Frame Length field specifies the length of the PHY payload field. The valid length can be from 7 to 63 bytes. The frame format is shown as below:

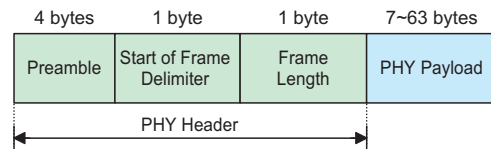

PHY Layer Frame Format

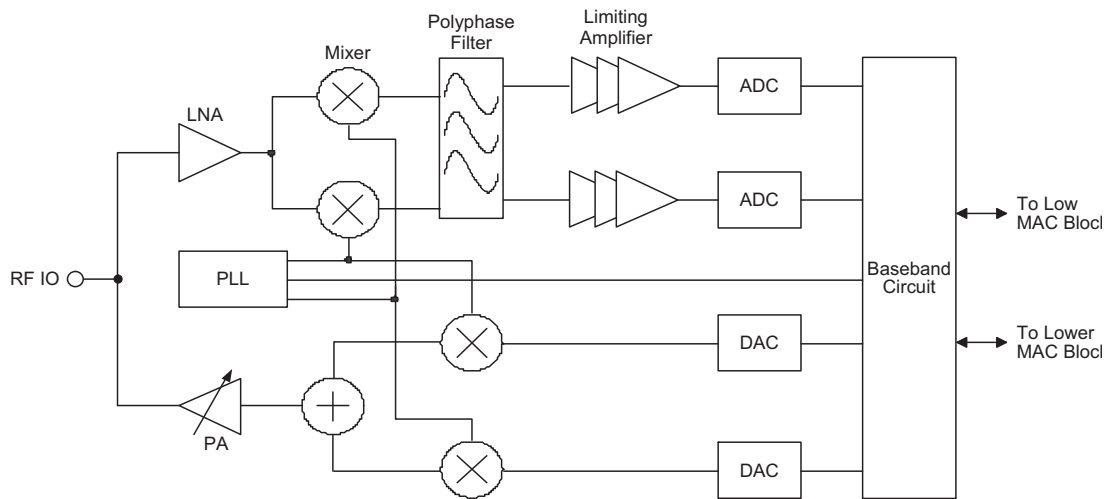

PHY Block architecture

RF Transceiver Low MAC Block

The RF Transceiver MAC provides plenty of hardware-assisted features to relieve the host MCU power requirement. Besides providing reliable wireless packet transactions between two nodes, it also handles data and command transfer between the network and the physical layers PHY.

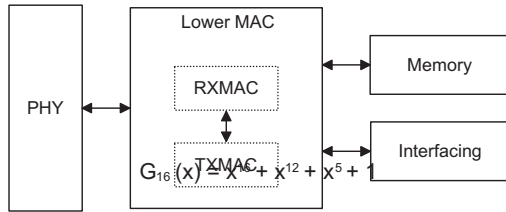

Lower MAC Block Diagram

MAC Frame Format

- Data Frame
The address field contains the broadcast address (0xFFFF-FFFF) or destination address. The bit 0 of frame control (FC) field is used for Ack-Request which specifies whether an acknowledgement is required

from the recipient device. If the bit is "1", the recipient device shall send an acknowledgement frame back after determining that the received frame is valid. The bit 1 of FC field is "0" for data frame. The length of payload field is variable from 0 to 56 bytes. The frame check sequence (FCS) is calculated over the address field, FC field and the payload. The polynomial is degree 16:

$$G_{16}(x) = x^{16} + x^{12} + x^5 + 1$$

- Acknowledgement Frame

The length of acknowledgement frame is always 5 bytes. Bit 1 of FC field is 1 for ACK frame. The payload field, containing user information of acknowledgement frame, can be configured by SREG0x03 and SREG0x04. The FCS is calculated over the FCS of the received packet, FC field and the payload field. The polynomial is degree 16:

$$G_{16}(x) = x^{16} + x^{12} + x^5 + 1$$

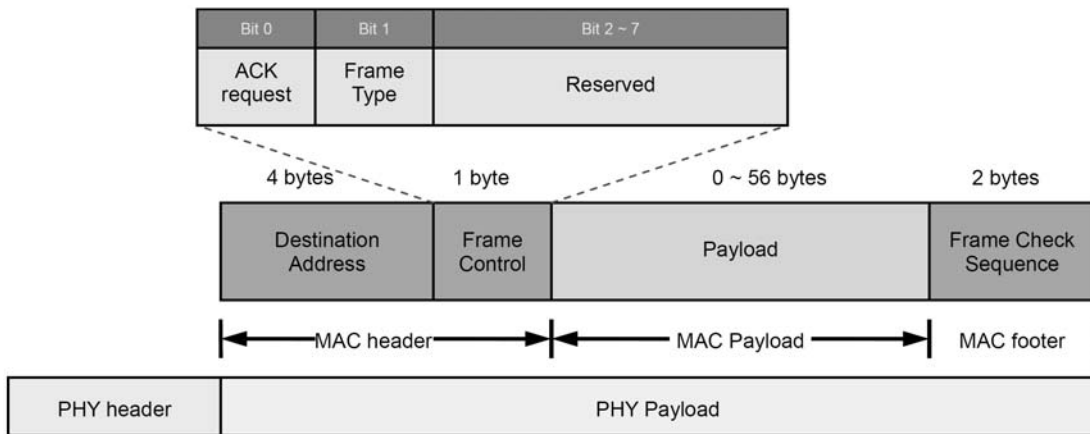

Data Frame

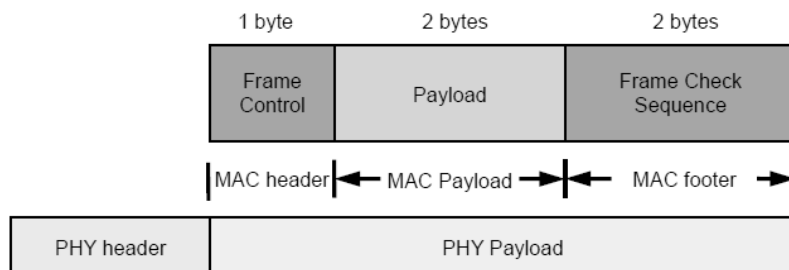

Acknowledgement Frame

TXMAC

When the TXFIFO is triggered, the TXMAC gets the data from TXFIFO to generate a 16-bit FCS and sends the packet to the PHY layer of the TX immediately. If necessary, TXMAC handles the retransmission, when the acknowledgement packet is not received. The block diagram of a TXMAC is shown below.

RXMAC

The RX PHY of the RF Transceiver filters signals and tracks the synchronization symbols. If a packet passes the filtering, RXMAC performs frame type parsing, address recognition and FCS checking. If the destination address is broadcast address or matches its own identity, configured by SREG0x05 to SREG0x08, and the FCS check is passed, an interrupt is issued at SREG0x31 [3] to indicate a valid packet is received. Meanwhile, the frame length field of PHY header and PHY payload will be stored in RXFIFO. Unqualified packets are skipped.

RXFIFO0 and RXFIFO1 are mapped into the 64-byte memory space from 0x300H to 0x33FH as Ping-Pong FIFOs. If Ping-Pong RX mode is enabled by SREG0x34

[0], RXMAC automatically switches between RXFIFO0 and RXFIFO1 to store incoming frame whenever a new packet comes. When the MCU host reads the long address memory 0x300H, the RXMAC will change the flag of SREG0x34 [1] automatically. For manually controlled RX operation, if the value of the flag SREG0x34 [1] is "0", the RXFIFO0 shall be read. Otherwise, the RXFIFO1 shall be read.

In the above diagram, the current status of each frame is represented in SREG0x30. SREG0x30 [7] means "RXFIFO full" indicating the two RXFIFOs are occupied. If the MCU host cannot read the RXFIFO in time, the value of SREG0x30 [7] will be set to "1". Once the MCU host read the RXFIFO, the value of the SREG0x30 [7] will be set to "0" automatically.

The contents of the RXFIFO can be flushed only by the following three ways: (1) the MCU host reads length field of RXFIFO and the last byte of the packet, (2) the host issues an RX flush, and (3) the software reset by SREG0x2A [0]. Note that RXFIFO is ready to receive next packet and all the data in RFIFO will be overwritten after RXFIFO flushed.

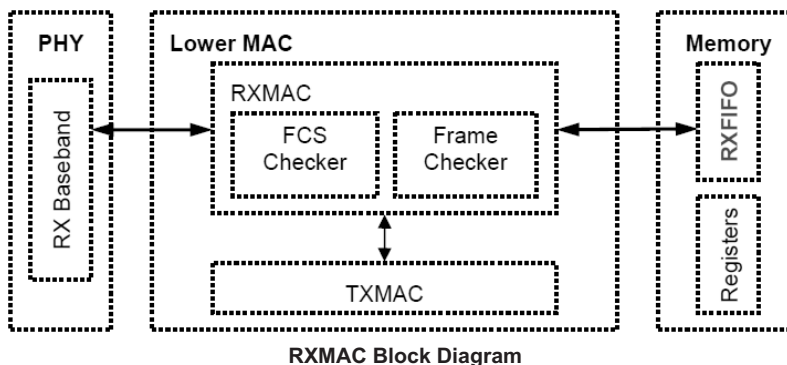
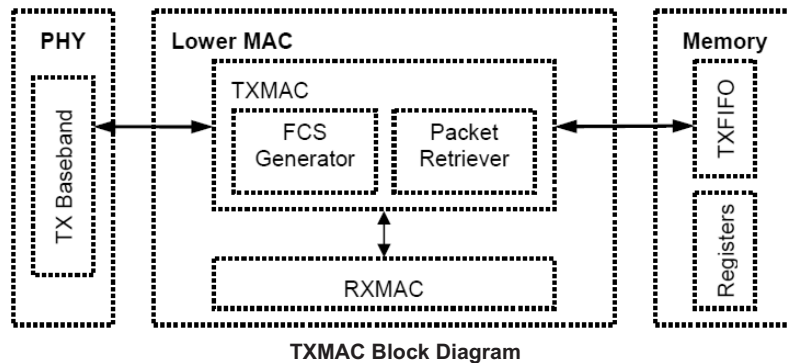

Auto Acknowledgement

The RXMAC supports automatically acknowledgement. If and only if the packet is successfully received and an Ack-Request bit, Bit 0, in the FC field of the received packet is set, RXMAC informs TXMAC to send an acknowledgement packet automatically. User should write the FC field correctly into the TX FIFO.

If an acknowledgement is requested and the replied ACK frame is not received, the transmitter automatically resends the packet until the maximum retransmission times, specified in SREG0x1B [7:4], are reached. To utilize the function properly, the corresponding registers of both transmitting and receiving sides need to be set correctly.

- Auto-retransmission on TX Side
To automatically retransmit a packet when an ACK is not received, SREG0x1B [2] is required to be set to "1".
- Auto-acknowledgement on RX Side
To automatically reply an ACK packet when Ack-Request bit is set to "1", SREG0x00 [5] should be set to "0".

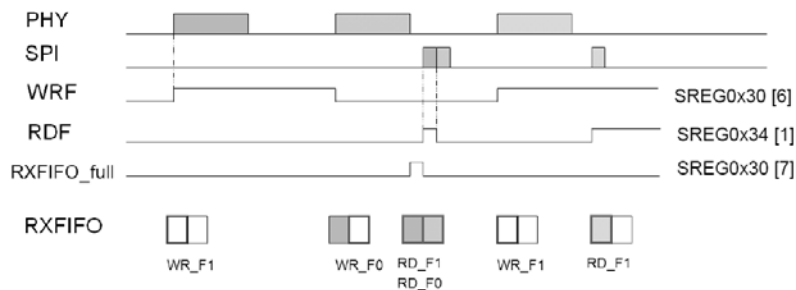

RF Transceiver Memory Block

The Memory Block of the RF Transceiver is implemented by the SRAM. As the following Memory Block diagram shown, the RF Transceiver Memory is composed of registers and FIFOs, which can be accessed by the SPI interface. They are categorized into two kinds of address spaces. One is the short address space; the other is the long address space.

Registers

Registers provide control bits and status flags for the RF Transceiver operations, including transmission, reception, interrupt control, MAC/baseband/RF parameter settings, etc. The registers are divided into two types according to addressing mode as listed below.

- Short address register (6-bit short addressing mode register, total 64 registers)
- Long address register (10-bit long addressing mode register, total 128 registers)

Short address registers are accessed by short addressing mode with valid addresses ranging from 0x00H to 0x3FH. Long address registers are accessed by long addressing mode with valid addresses ranging from 0x200H to 0x27FH. Short registers are accessed faster than long registers. Please refer to the following SPI Interface section for detailed addressing rules via SPI interface.

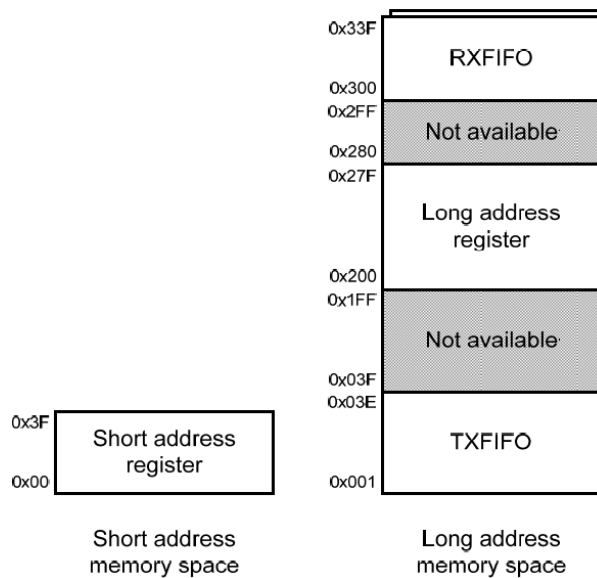

Memory Space Diagram

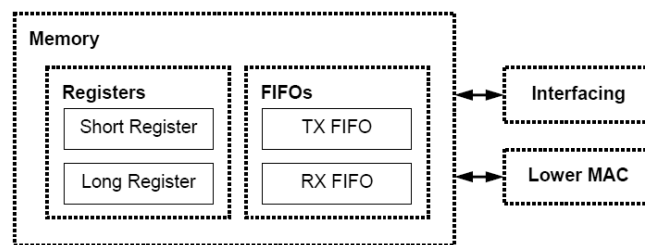

Memory Block Diagram

Short Address Registers

Legend: r=reserved

| Addr. | File Name | Bit 7 | Bit 6 | Bit 5 | Bit 4 | Bit 3 | Bit 2 | Bit 1 | Bit 0 | Value on POR |
|-------|-----------|-------------|----------|----------|----------|----------|----------|----------|----------|--------------|
| 0x00 | RXMCR | r | r | NOACKRSP | r | r | r | r | r | 0000 0000 |
| 0x03 | AUINFL | AUINF7 | AUINF6 | AUINF5 | AUINF4 | AUINF3 | AUINF2 | AUINF1 | AUINF0 | 0000 0000 |
| 0x04 | AUINFH | AUINF15 | AUINF14 | AUINF13 | AUINF12 | AUINF11 | AUINF10 | AUINF9 | AUINF8 | 0000 0000 |
| 0x05 | DADR_0 | DADR[7:0] | | | | | | | | 0000 0000 |
| 0x06 | DADR_1 | DADR[15:8] | | | | | | | | 0000 0000 |
| 0x07 | DADR_2 | DADR[23:16] | | | | | | | | 0000 0000 |
| 0x08 | DADR_3 | DADR[31:24] | | | | | | | | 0000 0000 |
| 0x0D | RXFLUSH | r | WAKEPOL | WAKEPAD | r | r | PTX | r | RXFLUSH | 0110 0000 |
| 0x12 | ACKTO | r | MATOP6 | MATOP5 | MATOP4 | MATOP3 | MATOP2 | MATOP1 | MATOP0 | 0011 1001 |
| 0x17 | PACON | r | r | r | PAONTS3 | PAONTS2 | PAONTS1 | PAONTS0 | r | 0000 0010 |
| 0x18 | TXCON | r | r | TXONTS3 | TXONTS2 | TXONTS1 | TXONTS0 | r | r | 1000 1000 |
| 0x1B | TXTRIG | TXRTYN3 | TXRTYN2 | TXRTYN1 | TXRTYN0 | r | TXACKREQ | r | TXTRIG | 0011 0000 |
| 0x22 | WAKECTL | IMMWAKE | REGWAKE | r | r | r | r | r | r | 0100 0000 |
| 0x24 | TXSR | TXRETRY3 | TXRETRY2 | TXRETRY1 | TXRETRY0 | r | r | r | TXNS | 0000 0000 |
| 0x26 | GATECLK | r | r | SPISYNC | r | r | ENTXM | r | r | 0000 0000 |
| 0x2A | SOFRST | r | r | r | r | r | r | RSTBB | RSTMAC | 0000 0000 |
| 0x2E | TXPEMISP | TXPET3 | TXPET2 | TXPET1 | TXPET0 | r | r | r | r | 0111 0101 |
| 0x30 | RXSR | RXFFFULL | WRFF1 | r | RXFFOVFL | RXCRCERR | r | r | r | 0000 0000 |
| 0x31 | ISRSTS | r | WAKEIF | r | r | RXIF | r | r | TXNIF | 0000 0000 |
| 0x32 | INTMSK | r | WAKEMSK | r | r | RXMSK | r | r | TXNMSK | 1111 1111 |
| 0x34 | BATRXF | r | r | BATIND | r | r | r | RDFF1 | RXFIFO2 | 0000 0000 |
| 0x35 | SLPACK | SLPACK | WAKECNT6 | WAKECNT5 | WAKECNT4 | WAKECNT3 | WAKECNT2 | WAKECNT1 | WAKECNT0 | 0000 0000 |
| 0x36 | RFCTL | r | r | r | WAKECNT8 | WAKECNT7 | RFRST | r | r | 0000 0000 |
| 0x38 | BBREG0 | r | r | r | r | r | r | r | TURBO | 1000 0001 |

Short Address Registers List

Long Address Registers

Legend: r=reserved

| Addr. | File Name | Bit 7 | Bit 6 | Bit 5 | Bit 4 | Bit 3 | Bit 2 | Bit 1 | Bit 0 | Value on POR |
|-------|-----------|-----------|-----------|-----------|-----------|-----------|-----------|-----------|-----------|--------------|
| 0x200 | RFCTRL0 | CHANNEL3 | CHANNEL2 | CHANNEL1 | CHANNEL0 | r | r | r | r | 0000 0001 |
| 0x201 | RFCTRL1 | r | r | r | r | r | r | VCORX1 | VCORX0 | 0000 0001 |
| 0x202 | RFCTRL2 | r | RXFC0-1 | RXFC0-0 | r | r | r | r | r | 1000 0100 |
| 0x203 | RFCTRL3 | TXGB4 | TXGB3 | TXGB2 | TXGB1 | TXGB0 | r | r | r | 0000 0000 |
| 0x204 | RFCTRL4 | r | r | r | r | r | RXFCO | RXD2CO1 | RXD2CO0 | 0000 0000 |
| 0x205 | RFCTRL5 | BATTH3 | BATTH2 | BATTH1 | BATTH0 | r | r | r | r | 0000 0000 |
| 0x206 | RFCTRL6 | TXFBW1 | TXFBW0 | 32MXCO1 | 32MXCO0 | BATEN | r | r | r | 1111 0000 |
| 0x207 | RFCTRL7 | r | r | r | RXFC2 | r | r | r | r | 0000 0000 |
| 0x208 | RFCTRL8 | r | TXD2CO0 | r | r | r | r | r | r | 0000 1100 |
| 0x209 | SLPCAL_0 | SLPCAL7 | SLPCAL6 | SLPCAL5 | SLPCAL4 | SLPCAL3 | SLPCAL2 | SLPCAL1 | SLPCAL0 | 0000 0000 |
| 0x20A | SLPCAL_1 | SLPCAL15 | SLPCAL14 | SLPCAL13 | SLPCAL12 | SLPCAL11 | SLPCAL10 | SLPCAL9 | SLPCAL8 | 0000 0000 |
| 0x20B | SLPCAL_2 | SLPCALRDY | r | r | SLPCALEN | SLPCAL19 | SLPCAL18 | SLPCAL17 | SLPCAL16 | 0000 0000 |
| 0x211 | IRQCTRL | r | r | r | r | r | r | IRQCTRL | r | 0000 0000 |
| 0x22F | TESTMODE | MPSPI | r | r | r | r | TESTMODE2 | TESTMODE1 | TESTMODE0 | 0010 1000 |
| 0x23D | GPIODIR | r | r | GDIRCTRL2 | GDIRCTRL1 | GDIRCTRL0 | GPIO2DIR | GPIO1DIR | GPIO0DIR | 0011 1111 |
| 0x23E | GPIO | r | r | r | r | r | GPIO2 | GPIO1 | GPIO0 | 0000 0000 |
| 0x250 | RFCTRL50 | r | r | r | DCPOC | DCOPC3 | DCOPC2 | DCOPC1 | DCOPC0 | 0000 0000 |
| 0x251 | RFCTRL51 | DCOPC5 | DCOPC4 | r | r | r | r | r | r | 0000 0000 |
| 0x252 | RFCTRL52 | SLCTRL6 | SLCTRL5 | SLCTRL4 | SLCTRL3 | SLCTRL2 | SLCTRL1 | SLCTRL0 | 32MXCTRL | 1111 1111 |
| 0x253 | RFCTRL53 | r | FIFOPS | DIGITALPS | P32MXE | PACEN2 | PACTRL2-2 | PACTRL2-1 | PACTRL2-0 | 0000 0000 |
| 0x254 | RFCTRL54 | 1MCSN | 1MFRCH6 | 1MFRCH5 | 1MFRCH4 | 1MFRCH3 | 1MFRCH2 | 1MFRCH1 | 1MFRCH0 | 0000 0000 |
| 0x259 | RFCTRL59 | r | r | r | r | r | r | r | PLLOPT3 | 0000 0001 |
| 0x273 | RFCTRL73 | VCOTXOPT1 | VCOTXOPT0 | r | r | PLLOPT2 | PLLOPT1 | PLLOPT0 | r | 0000 0000 |
| 0x274 | RFCTRL74 | PACEN0 | PACTRL0-2 | PACTRL0-1 | PACTRL0-0 | PACEN1 | PACTRL1-2 | PACTRL1-1 | PACTRL1-0 | 1100 1010 |
| 0x275 | RFCTRL75 | r | r | r | r | SCLKOPT3 | SCLKOPT2 | SCLKOPT1 | SCLKOPT0 | 0001 0101 |
| 0x276 | RFCTRL76 | r | r | r | r | r | SCLKOPT6 | SCLKOPT5 | SCLKOPT4 | 0000 0001 |
| 0x277 | RFCTRL77 | r | r | SLPSEL1 | SLPSEL0 | SLPVCTRL1 | SLPVCTRL0 | SLPVSEL1 | SLPVSEL0 | 0000 1000 |

FIFOs serve as the temporary data buffers for data transmission and reception. Each FIFO holds only one packet at a time. TXFIFO, the transmission FIFO, is composed of 62-byte FIFO. RX FIFO, the receiving FIFO, is composed of two 64-byte FIFOs.

- TX FIFO - (62 bytes)
The TXMAC gets the to-be transmitted data from the 62-byte TXFIFO. The memory space of TXFIFO is from "0x001" to "0x03E" and contains a FL field, address field, FC field and payload field. The FL field indicates the length of the address field, FC field and the payload field. The valid value of frame length is from 5 to 61 bytes.
- RX FIFO - RXFIFO0 (64 bytes) and RXFIFO1 (64 bytes)
A RXFIFO is composed of two 64-byte FIFOs (RXFIFO0 and RXFIFO1) to store the incoming packet. Each of them is designed to store one packet at a time. RXFIFO contains a FL field, address field, FC field, payload field and FCS field. The memory space of RXFIFO is from "0x300" to "0x33F". The FL field, which is extracted from the PHY header, indicates the length of the address field, FC field, the payload field and FCS field. The valid value of frame length is from 7 to 63 bytes. The value of the FL field of PHY header is calculated by adding 2, the length of FCS field of MAC frame, and the above mentioned value up.

RF Transceiver Power Management Block

Almost all wireless sensor network applications require low-power consumption to lengthen battery life. Typical battery-powered device is required to be operated over years without replacing its battery. The RF Transceiver achieves low active current consumption of both the digital and the RF/analog circuits by controlling the supply voltage and using low-power architecture.

The RF Transceiver has four power saving modes that will be further described in Power Saving Modes Section. For ultra low-power operation, Power-down mode is available which consumes around 0.1µA while the RF Transceiver is powered down. All data stored in registers and FIFOs will be lost under Power-down mode. In this mode, The RF Transceiver is able to wake up by a wake-up input signal. Except Power down mode, the data in the registers/FIFOs are retained during the other power saving modes.

Power Supply Scheme

The table below lists the recommended values of the external bypass capacitors for each power pin of the RF Transceiver. For the power pins VDD_RF1 and VDD_3V, an extra bypass capacitor is needed for the decoupling purpose while the rest of the power pins require only one bypass capacitor. The path length between the bypass capacitors to each pin should be made as short as possible.

| Pin Name | Bypass Capacitor 1 | Bypass Capacitor 2 |
|----------|--------------------|--------------------|
| VDD_RF1 | 47pF | 10nF |
| VDD_RF2 | 47pF | |
| VDD_D | 10nF | |
| VDD_3V | 10µF | 10nF |
| VDD_A | 47pF | |
| VDD_PLL | 47pF | |
| VDD_CP | 10nF | |

Recommended External Bypass Capacitors

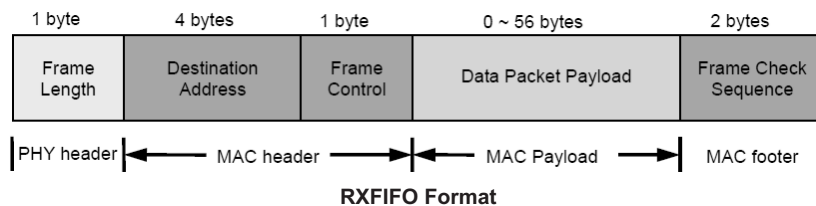
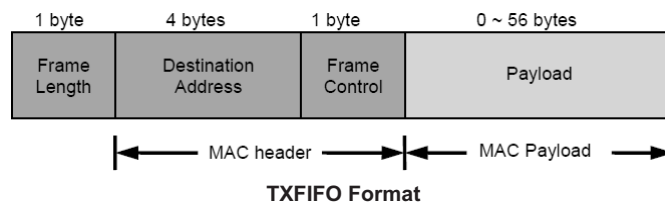

DC-DC Converter

There are two ways to supply power to the RF Transceiver. One is through the on-chip DC-DC converter and the other is without the DC-DC converter. With DC-DC converter, the RF Transceiver consumes lower current. With the DC-DC converter, power pins including VDD_RF1, VDD_RF2, VDD_D, VDD_A, VDD_PLL and VDD_CP should be hardwired to the DC-DC converter output, pin VDD_2V2 of the RF Transceiver. Without DC-DC converter, all the power pins should be directly hardwired to the external supplied voltage.

For this device the on-chip DC-DC converter is not used. User can set LREG0x250 [4] to '0' and LREG0x273 to "0x4E" to bypass the DC-DC converter. When the DC-DC converter is bypassed, pins VDD_2V2 and VDD_3V are shorted internally.

Battery Monitor

The RF Transceiver provides a function to monitor the RF Transceiver supplied voltage. A 4-bit voltage threshold can be configured so that when the supplied voltage is lower than the threshold, the system will be notified. For battery monitor function, please refer to the Section named Battery Monitor Operations.

Power Saving Modes

The RF Transceiver power modes are classified into the following four modes:

- IDLE: RF circuit off. The regulator, oscillator, and digital circuits are on.
- STANDBY: RF/MAC/BB shutdown with sleep and 32MHz clocks remain active
- DEEP_SLEEP: All power is shutdown except the power to the digital circuits and registers and FIFOs data are retained.

- POWER_DOWN: All power is shutdown. Registers and FIFOs data are not retained, a wake-up input signal can wake up the RF Transceiver.

IDLE mode is rarely used because the device should at least always turns on its RX circuit to capture the on-air RF signals. The only difference between STANDBY mode and DEEP_SLEEP mode is the power status of the sleep clock. To wake the RF Transceiver up, the MCU host has to control the time of sleep process.

The power management control is used for the low power operation of MAC and baseband modules. It manages to turn on and off the 32 MHz clock when the RF Transceiver goes into power saving mode. By turning off the 32 MHz clock, the MAC and baseband circuits become inactive regardless whether their power supplies exist or not. All the digital modules are clock-gated automatically. That means only when a module is functioning, its clock would then be turned on. This approach efficiently decreases certain amount of the current consumption.

RF Transceiver Interfacing Block

The interfacing block mainly includes three parts named SPI interface, GPIO and Interrupt signal. Each of them is described as followings.

SPI Interface

The MCU communicates with the RF Transceiver via an internal SPI interface to read/write the control registers and FIFOs. The SPI interface connected to the MCU SPI master in the RF Transceiver has the following features:

- A 4-line slave SPI interface composed of: SEN (SPI enable), SCLK (SPI Clock), SI (Serial Data Input) and SO (Serial Data Output).
- Most significant bit (MSB) of all addresses and data transfers on the SPI interface is done first.

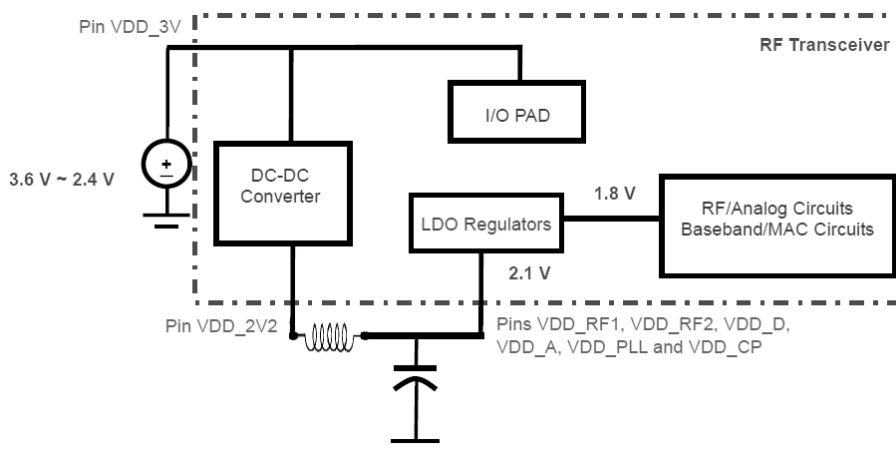

Block Diagram of Voltage Regulators with DC-DC Converter On/Bypass

◆ SPI Addressing Format

MSB of addressing frame indicates the addressing mode of the packet. The length of address field is 6 or 10 bits for short and long addressing mode respectively. Bit 0 is a one-bit read/write indicator.

| Short Addressing Format | Bit 7 | Bit 6 ~ 1 | Bit 0 |
|-------------------------|-------|-------------|---------------------|
| | 0 | 0x00 ~ 0x3F | Read: 0 Write: 1 |

| Long Addressing Format | Bit 11 | Bit 10 ~ 1 | Bit 0 |
|------------------------|--------|---------------|---------------------|
| | 1 | 0x000 ~ 0x33F | Read: 0 Write: 1 |

SPI Addressing Format

◆ SPI Characteristics

| Parameter | Symbol | Min. | Max. | Unit | Conditions |
|--------------------------|------------|------|------|------|---|
| SCLK, clock frequency | f_{SCLK} | — | 5 | MHz | |
| SCLK low pulse duration | t_{CL} | 100 | — | ns | The minimum time SCLK must be low. |
| SCLK high pulse duration | t_{CH} | 100 | — | ns | The minimum time SCLK must be high. |
| SEN setup time | t_{SP} | 100 | — | ns | The minimum time SEN must be low before the first positive edge of SCLK. |
| SEN hold time | t_{NS} | 100 | — | ns | The minimum time SEN must be held low after the last negative edge of SCLK. |
| SI setup | t_{SD} | 25 | — | ns | The minimum time data must be ready at SI, before the positive edge of SCLK |
| SI hold time | t_{HD} | 25 | — | ns | The minimum time data must be held at SI, after the positive edge of SCLK. |
| Rise time | t_{RISE} | — | 25 | ns | The maximum rise time for SCLK and SEN. |
| Fall time | t_{FALL} | — | 25 | ns | The maximum fall time for SCLK and SEN. |

◆ SPI Timing Diagram

The following figures show the timing diagrams for the short and long addressing mode respectively. The MCU SPI master will initiate a read or write operation by asserting the interface enable signal SEN to low, toggling SCLK and sent the address field by SI. The interface enable signal SEN should be high when a transaction is completed.

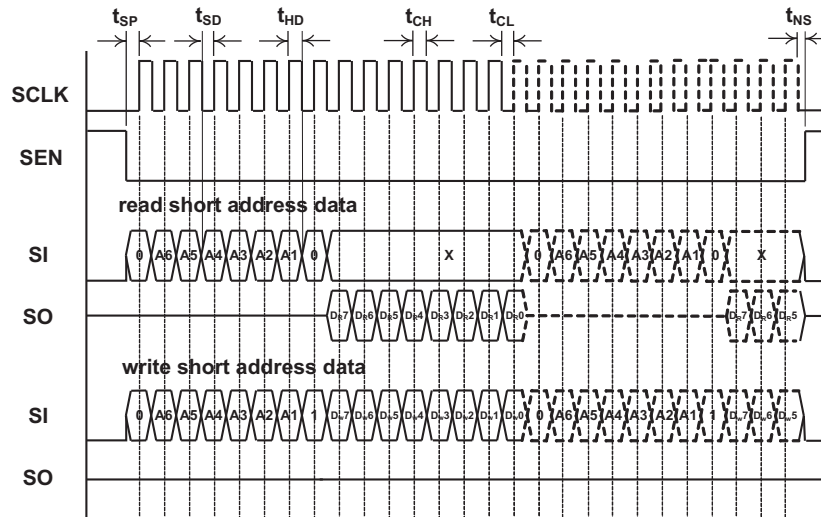

Timing Diagram of Short Addressing Mode

The SPI burst mode is provided for the access of long address memory space on a continuous basis. If SEN does not go high after the 8-bit write data and the SCLK continuously toggles, the followed 8-bit write data is written to the next address field. Same for the read access, the data of the next address will be read. The SPI burst mode is only available for the long-address mode.

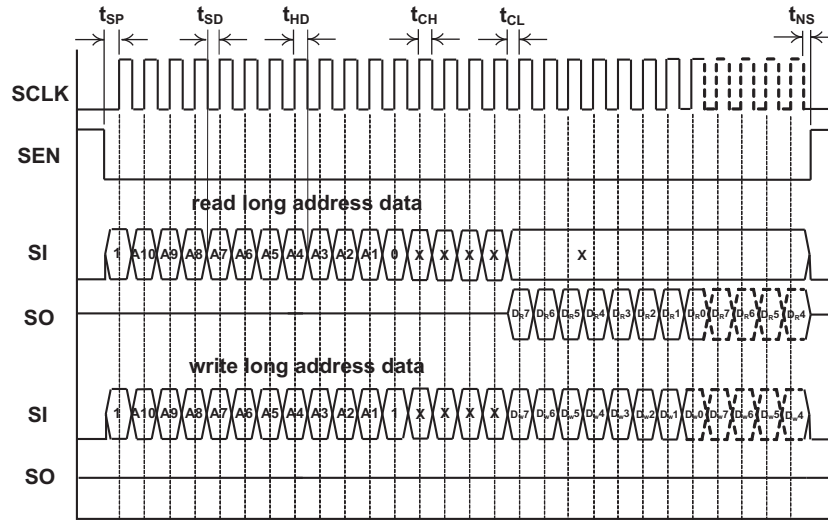

Timing Diagram of Long Addressing Mode

GPIO

The RF Transceiver has 3 digital GPIO pins. Each GPIO pin can be configured as input or output by LREG0x23D respectively. When being configured as an output pad, the driving capability is 4mA for GPIO0 and 1mA for GPIO1 and GPIO2. The status of these pins can be configured or read by LREG0x23E.

To benefit wide rang applications, GPIO0, GPIO1 and GPIO2 can be configured to control the external Power Amplifier (P.A.) and RF switch according to the current RF state automatically. Please refer to the following section named "External Power Amplifier Configuration" for details.

Interrupt Signal

The RF Transceiver provides an interrupt output pin named INT and the polarity of the interrupt signal is selectable. The RF Transceiver issues interrupts to the MCU host on three possible events. If one of the three events happens, the RF Transceiver sets the corresponding status bit in SREG0x31. If the corresponding

interrupt mask in SREG0x32 is clear (i.e. equals 0), an interrupt will be issued on the interrupt output pin INT. If the corresponding interrupt mask is set to 1 (masked), no interrupt will be issued, but the status is still present. Whenever the SREG0x31 register is read, the interrupt and the status are cleared. The three interrupt events are described as below:

- Wake-up Alert Interrupt (WAKEIF): Each time a wake-up event happens the RF Transceiver issues the interrupt event.
- Packet Received Interrupt (RXIF): This interrupt is issued when an available packet is received in the RXFIFO. An available packet means that it passes a RXMAC filter, which includes frame type identifying, address filtering and FCS check.
- TX FIFO Release Interrupt (TXNIF): This interrupt can be issued in two possible conditions. The two conditions are when a packet in TXFIFO is triggered and sent successfully, or when a packet is triggered and the retransmission is timed out.

RF Transceiver Application Guide

Some typical applications are described in this section to help user gains more understanding of the operation of the RF Transceiver.

RF Transceiver Hardware Connection

A typical application connection is shown in Application Circuit section. The MCU host serves as a master role, and the RF Transceiver serves as a slave role. For more information, refer to the Application Circuit section.

RF Transceiver Initialization

After the RF Transceiver is powered up, some registers need to be configured before the data transmission or reception. The procedure is described as below.

- Procedure List

| Parameter | Symbol | Min. | Max. | Unit | Conditions |
|-----------|--------|----------|----------------------------|------|--------------------------|
| SREG | 0x26 | GATECLK | Enable SPI sync function | 20 | |
| SREG | 0x17 | PACON1 | Increase PAON time | 08 | |
| SREG | 0x18 | FIFOEN | Increase TXON time | 94 | |
| SREG | 0x2E | TXPEMISP | VCO calibration period | 95 | |
| LREG | 0x200 | RFCTL0 | RF optimized control | 01 | |
| LREG | 0x201 | RFCTL1 | RF optimized control | 02 | |
| LREG | 0x202 | RFCTL2 | RF optimized control | E0 | |
| LREG | 0x204 | RFCTL4 | RF optimized control | 06 | |
| LREG | 0x206 | RFCTL6 | RF optimized control | C0 | 1M bps |
| LREG | 0x207 | RFCTL7 | RF optimized control | F0 | 1M bps |
| LREG | 0x208 | RFCTL8 | RF optimized control | 8C | |
| LREG | 0x23D | GPIODIR | For Setting GPIO to Output | 00 | |
| LREG | 0x250 | RFCTL50 | RF optimized control | 07 | DC-DC OFF |
| LREG | 0x251 | RFCTL51 | RF optimized control | C0 | |
| LREG | 0x252 | RFCTL52 | RF optimized control | 01 | |
| LREG | 0x259 | RFCTL59 | RF optimized control | 00 | |
| LREG | 0x273 | RFCTL73 | RF optimized control | 40 | |
| LREG | 0x274 | RFCTL74 | RF optimized control | C6 | DC-DC OFF |
| LREG | 0x275 | RFCTL75 | RF optimized control | 13 | |
| LREG | 0x276 | RFCTL76 | RF optimized control | 07 | |
| SREG | 0x32 | INTMSK | Enable all interrupt | 00 | |
| SREG | 0x2A | SOFTRST | Baseband Reset | 02 | |
| SREG | 0x36 | RFCTL | RF Reset | 04 | Reset RF State Machine |
| SREG | 0x36 | RFCTL | RF Reset | 00 | Release RF State Machine |

• Registers associated with Initialization

| Addr. | File Name | Bit 7 | Bit 6 | Bit 5 | Bit 4 | Bit 3 | Bit 2 | Bit 1 | Bit 0 | Value on POR |
|-------|-----------|-----------|-----------|-----------|-----------|-----------|-----------|-----------|-----------|--------------|
| 0x17 | PACON | r | r | r | PAONTS3 | PAONTS2 | PAONTS1 | PAONTS0 | r | 0000 0010 |
| 0x18 | TXCON | r | r | TXONTS3 | TXONTS2 | TXONTS1 | TXONTS0 | r | r | 1000 1000 |
| 0x26 | GATECLK | r | r | SPISYNC | r | r | ENTXM | r | r | 0000 0000 |
| 0x2A | SOFRST | r | r | r | r | r | r | RSTBB | RSTMAC | 0000 0000 |
| 0x2E | TXPEMISP | TXPET3 | TXPET2 | TXPET1 | TXPET0 | r | r | r | r | 0111 0101 |
| 0x32 | INTMSK | r | WAKEMSK | r | r | RXMSK | r | r | TXNMSK | 1111 1111 |
| 0x36 | RFCTL | r | r | r | WAKECNT8 | WAKECNT7 | RFRST | r | r | 0000 0000 |
| 0x200 | RFCTRL0 | CHANNEL3 | CHANNEL2 | CHANNEL1 | CHANNEL0 | r | r | r | r | 0000 0001 |
| 0x201 | RFCTRL1 | r | r | r | r | r | r | VCORX1 | VCORX0 | 0000 0001 |
| 0x202 | RFCTRL2 | r | RXFC0-1 | RXFC0-0 | r | r | r | r | r | 1000 0100 |
| 0x204 | RFCTRL4 | r | r | r | r | r | RXFCO | RXD2CO1 | RXD2CO0 | 0000 0000 |
| 0x206 | RFCTRL6 | TXFBW1 | TXFBW0 | 32MXCO1 | 32MXCO0 | BATEN | r | r | r | 1111 0000 |
| 0x207 | RFCTRL7 | r | r | r | RXFC2 | r | r | r | r | 0000 0000 |
| 0x208 | RFCTRL8 | r | TXD2CO0 | r | r | r | r | r | r | 0000 1100 |
| 0x23D | GPIODIR | r | r | GDIRCTRL2 | GDIRCTRL1 | GDIRCTRL0 | GPIO2DIR | GPIO1DIR | GPIO0DIR | 0011 1111 |
| 0x250 | RFCTRL50 | r | r | r | DCPOC | DCOPC3 | DCOPC2 | DCOPC1 | DCOPC0 | 0000 0000 |
| 0x251 | RFCTRL51 | DCOPC5 | DCOPC4 | r | r | r | r | r | r | 0000 0000 |
| 0x252 | RFCTRL52 | SLCTRL6 | SLCTRL5 | SLCTRL4 | SLCTRL3 | SLCTRL2 | SLCTRL1 | SLCTRL0 | 32MXCTRL | 1111 1111 |
| 0x259 | RFCTRL59 | r | r | r | r | r | r | r | PLLOPT3 | 0000 0001 |
| 0x273 | RFCTRL73 | VCOTXOPT1 | VCOTXOPT0 | r | r | PLLOPT2 | PLLOPT1 | PLLOPT0 | r | 0000 0000 |
| 0x274 | RFCTRL74 | PACEN0 | PACTRL0-2 | PACTRL0-1 | PACTRL0-0 | PACEN1 | PACTRL1-2 | PACTRL1-1 | PACTRL1-0 | 1100 1010 |
| 0x275 | RFCTRL75 | r | r | r | r | SCLKOPT3 | SCLKOPT2 | SCLKOPT1 | SCLKOPT0 | 0001 0101 |
| 0x276 | RFCTRL76 | r | r | r | r | r | SCLKOPT6 | SCLKOPT5 | SCLKOPT4 | 0000 0001 |

Change RF Channel Procedure

The RF Transceiver operates in 2.4GHz ISM band. The operating frequency is divided into 16 channels. The procedure to change the channels is described as below.

- Set the RF channel. Users can select one of the channels by configuring either LREG0x200 or LREG0x254.
- Turn on the TX MAC gated clock by setting SREG0x26 [2] to 1. To avoid an incomplete acknowledgment frame transmission happen during RF state machine reset period.
- Reset RF Transceiver state machine by setting SREG0x36 [2] to 1 and then set SREG0x36 [2] back to 0.
- After RF Transceiver reset, delay for a while to ensure the acknowledgment frame, if any, is successfully transmitted.
250 kbps mode: delay 550μs
1M bps mode: delay 300μs
- To disable the TX MAC gated clock by setting SREG26 [2] to 0.

Registers associated with Change Channel Procedure.

| Addr. | File Name | Bit 7 | Bit 6 | Bit 5 | Bit 4 | Bit 3 | Bit 2 | Bit 1 | Bit 0 | Value on POR |
|-------|-----------|----------|----------|----------|----------|----------|---------|---------|---------|--------------|
| 0x26 | GATECLK | r | r | SPISYNC | r | r | ENTXM | r | r | 0000 0000 |
| 0x36 | RFCTL | r | r | r | WAKECNT8 | WAKECNT7 | RFRST | r | r | 0000 0000 |
| 0x200 | RFCTRL0 | CHANNEL3 | CHANNEL2 | CHANNEL1 | CHANNEL0 | r | r | r | r | 0000 0001 |
| 0x254 | RFCTRL54 | 1MCSEN | 1MFRCH6 | 1MFRCH5 | 1MFRCH4 | 1MFRCH3 | 1MFRCH2 | 1MFRCH1 | 1MFRCH0 | 0000 0000 |

RF Transceiver Interrupt Configuration

The RF Transceiver issues a hardware interrupt at the internally connected interrupt signal line named INT to the MCU host. There are two related registers that need to be set correctly. All the interrupts are masked (disabled) by default. The interrupt mask should be removed by setting SREG0x32 in advance. The interrupt is by default sent to the MCU host as a falling edge signal after mask removed. The polarity can be configured by LREG0x211. The interrupt status can be read from SREG0x31 when it is triggered.

Registers associated with Interrupt Configuration

| Addr. | File Name | Bit 7 | Bit 6 | Bit 5 | Bit 4 | Bit 3 | Bit 2 | Bit 1 | Bit 0 | Value on POR |
|-------|-----------|-------|---------|-------|-------|-------|-------|--------|--------|--------------|
| 0x31 | ISRSTS | r | WAKEIF | r | r | RXIF | r | r | TXNIF | 0000 0000 |
| 0x32 | INTMSK | r | WAKEMSK | r | r | RXMSK | r | r | TXNMSK | 1111 1111 |
| 0x211 | IRQCTRL | r | r | r | r | r | r | IRQPOL | r | 0000 0000 |

RF Transceiver External Power Amplifier Configuration

To enable the Power Amplifier (P.A.), users can set LREG0x22F [2:0] value to 0x001B. This register setting integrates the P.A. enable and the RF Switch Control (TX branch, RX branch) by utilizing GPIO0, GPIO1 and GPIO2. If the RF Transceiver is in TX mode, the GPIO0 (external P.A. enable) and GPIO1 (TX branch enable) will be pulled HIGH, and GPIO2 (RX branch enable) will be pulled LOW. If the RF Transceiver is in RX mode, the GPIO0 and GPIO1 will be pulled LOW, and GPIO2 will be pulled HIGH. The status of GPIO pins are automatically changed corresponding to TX/RX mode of the RF Transceiver.

- TX mode: [GPIO0, GPIO1, GPIO2] = [HIGH, HIGH, LOW]
- RX mode: [GPIO0, GPIO1, GPIO2] = [LOW, HIGH, HIGH]

Registers associated with External Power Amplifier Configuration

| Addr. | File Name | Bit 7 | Bit 6 | Bit 5 | Bit 4 | Bit 3 | Bit 2 | Bit 1 | Bit 0 | Value on POR |
|-------|-----------|-------|-------|-------|-------|-------|-----------|-----------|-----------|--------------|
| 0x22F | TESTMODE | MSPI | r | r | r | r | TESTMODE2 | TESTMODE1 | TESTMODE0 | 0010 1000 |

RF Transceiver Turbo Mode Configuration

The RF Transceiver provides 1M bps Turbo mode to transmit and receive data at a higher data rate. Turbo mode provides an added capability for applications which require more bandwidth. The application circuits need not any modification for Turbo mode.

To use the RF Transceiver in 250k and 1M bps, the following registers need to be configured as below.

| Address Mode | Addr. | Register Name | Descriptions | Value (hex) | |
|--------------|-------|---------------|--------------------------|-------------|------|
| | | | | 250k | 1M |
| LREG | 0x206 | RFCTL6 | RF optimized control | 0x00 | 0xC0 |
| LREG | 0x207 | RFCTL7 | RF optimized control | 0xE0 | 0xF0 |
| SREG | 0x38 | BBREG0 | Enable Normal/Turbo mode | 0x80 | 0x81 |
| SREG | 0x2A | SOFRST | Baseband Reset | 0x02 | |

Registers associated with External Power Amplifier Configuration

| Addr. | File Name | Bit 7 | Bit 6 | Bit 5 | Bit 4 | Bit 3 | Bit 2 | Bit 1 | Bit 0 | Value on POR |
|-------|-----------|--------|--------|---------|---------|-------|-------|-------|--------|--------------|
| 0x2A | SOFRST | r | r | r | r | r | r | RSTBB | RSTMAC | 0000 0000 |
| 0x38 | BBREG0 | r | r | r | r | r | r | r | TURBO | 1000 0001 |
| 0x206 | RFCTRL6 | TXFBW1 | TXFBW0 | 32MXCO1 | 32MXCO0 | BATEN | r | r | r | 1111 0000 |
| 0x207 | RFCTRL7 | r | r | r | RXFC2 | r | r | r | r | 0000 0000 |

Typical RF Transceiver TX Operation

The TXMAC inside the RF Transceiver will automatically generate the preamble, Start-of-Frame Delimiter and the FCS when transmitting. The MCU host must write all other frame fields into TXFIFO for TX operation. To send a packet in TX FIFO, there are several steps to follow:

Fill necessary data in TXFIFO. The format of TXFIFO is as follows:

- ◆ TXFIFO Address

| 0x001 | | 0x0+N | |
|--------------|---------------------|---------------|---------|
| 1 Byte | 4 Bytes | 1 Byte | N Bytes |
| Frame Length | Destination Address | Frame Control | Payload |

- Set Ackreq by SREG0x1B [2], if an acknowledgement / retransmission is required. The RF Transceiver automatically retransmits the packet till the number of the Max trial times specified in SREG1B [7:4] is reached, if there is no acknowledgement received.
- By triggering SREG0x1B [0], the TXMAC will send the packet immediately. This bit will be automatically cleared.
- Wait for the interrupt status shown in SREG0x31 [0]. If retransmission is not required, SREG0x31 [0] indicates the packet is successfully transmitted.
- Check SREG0x24 [0] to see if transmission is successful. If SREG0x24 [0] is equal to 0, it means that the transmission is successful and the ACK was received. The number of times of the retransmission can be read at SREG0x24 [7:4]. If SREG0x24 [0] is equal to 1, it means that the transmission failed and ACK was not received.

Registers associated with Typical TX Operation

| Addr. | File Name | Bit 7 | Bit 6 | Bit 5 | Bit 4 | Bit 3 | Bit 2 | Bit 1 | Bit 0 | Value on POR |
|-------|-----------|----------|----------|----------|----------|-------|----------|-------|--------|--------------|
| 0x1B | TXTRIG | TXRTYN3 | TXRTYN2 | TXRTYN1 | TXRTYN0 | r | TXACKREQ | r | TXTRIG | 0011 0000 |
| 0x24 | TXSR | TXRETRY3 | TXRETRY2 | TXRETRY1 | TXRETRY0 | r | r | r | TXNS | 0000 0000 |
| 0x31 | ISRSTS | r | WAKEIF | r | r | RXIF | r | r | TXNIF | 0000 0000 |

Typical RF Transceiver RX Operation

When a valid packet is received, an interrupt is issued at SREG0x31 [3]. The MCU host can read the whole packet inside the RXFIFO. The RXFIFO is flushed when the frame length field and the last byte of RXFIFO are read, or when the MCU host triggers a RX flush by SREG0x0D [0]. The format of RXFIFO is as follows:

- RXFIFO Address

| 0x300 | | 0x307+N | | |
|--------------|---------------------|---------------|---------|---------------|
| 1 Byte | 4 Bytes | 1 Byte | N Byte | 1 Bytes |
| Frame Length | Destination Address | Frame Control | Payload | Frame Control |

- Registers associated with Typical RX Operation

| Addr. | File Name | Bit 7 | Bit 6 | Bit 5 | Bit 4 | Bit 3 | Bit 2 | Bit 1 | Bit 0 | Value on POR |
|-------|-----------|-------|--------|-------|-------|-------|-------|-------|---------|--------------|
| 0x0D | RXFLUSH | r | r | r | r | r | PTX | r | RXFLUSH | 0110 0000 |
| 0x31 | ISRSTS | r | WAKEIF | r | r | RXIF | r | r | TXNIF | 0000 0000 |

RF Transceiver Power Saving Operation

Standby, Deep-Sleep and Power-Down Modes are designed for the RF Transceiver. It is only allowed to switch between power saving modes and active mode. The following settings are effective in active mode only.

Standby Mode

Shutdown RF/MAC/BB, while the voltage regulator, partial 32MHz clock and sleep clock remains active.

- Set LREG0x277 [5:4] to "00" to select for STANDBY Mode.
- Set LREG0x277 [3:2] to "10" for enable sleep voltage automatically controlled by internal circuit.
- Set LREG0x253 [4] to "1" to enable partial 32MHz clock.

Deep_Sleep Mode

All power is shutdown except the power to the digital circuits and sleep clock. Registers and FIFOs are retained.

- Set LREG0x277 [5:4] to "00" to select for DEEP_SLEEP Mode.
- Set LREG0x277 [3:2] to "10" for enable sleep voltage automatically controlled by internal circuit.

Power Down Mode

All power is shutdown. Registers and FIFOs data are not retained. Initialization is needed after the RF Transceiver back to active mode. Only the internal connected interrupt line named WAKE can wake the RF Transceiver up.

- Set LREG0x277 [5:4] to "11" to select for POWER DOWN Mode.
- Set LREG0x277 [3:2] to "10" for enable sleep voltage automatically controlled by internal circuit.
- Set LREG0x253 [6:5] to "11" to connect the FIFO power and digital circuit power to ground.

If the internal connected interrupt line named WAKE is going to be used to wake the RF Transceiver up, the configuration for WAKE line should be included. Refer to the following WAKE Line Wake-up Section for details. The on-chip DC-DC converter is not used for this device and then bypasses it by setting the DCPOC bit in LREG0x250 register to 0.

After the necessary settings mentioned above are configured, user can execute the following procedures to disable SPISYNC and place the RF Transceiver to the desired power saving mode.

- Set SREG0x26 [5] to "0" to disable SPISYNC.
- Set SREG0x35 [7] to "1" to place the RF Transceiver to power saving mode.

Registers associated with Power Saving Operation:

| Addr. | File Name | Bit 7 | Bit 6 | Bit 5 | Bit 4 | Bit 3 | Bit 2 | Bit 1 | Bit 0 | Value on POR |
|-------|-----------|--------|----------|-----------|----------|-----------|-----------|-----------|-----------|--------------|
| 0x26 | GATECLK | r | r | SPISYNC | r | r | ENTXM | r | r | 0000 0000 |
| 0x35 | SLPACK | SLPACK | WAKECNT6 | WAKECNT5 | WAKECNT4 | WAKECNT3 | WAKECNT2 | WAKECNT1 | WAKECNT0 | 0000 0000 |
| 0x250 | RFCTRL50 | r | r | r | DCPOC | DCOPC3 | DCOPC2 | DCOPC1 | DCOPC0 | 0000 0000 |
| 0x253 | RFCTRL53 | r | FIFOPS | DIGITALPS | P32MXE | PACEN2 | PACTRL2-2 | PACTRL2-1 | PACTRL2-0 | 0000 0000 |
| 0x277 | RFCTRL77 | r | r | SLPSEL1 | SLPSEL0 | SLPVCTRL1 | SLPVCTRL0 | SLPVSEL1 | SLPVSEL0 | 0000 1000 |

RF Transceiver Wake-up Operation

After entering into Power Saving Mode, the RF Transceiver could be waked up by the internal register trigger. One and only one method should be used for wake-up operation.

- Configure clock recovery time
WAKECNT, used to calculate for recovery time of 32MHz clock of the RF Transceiver, should be set in advance. User shall follow the following two steps to configure WAKECNT.

- ♦ Calculate the period of sleep clock

Set LREG0x20B [4] to 1 and then keep polling LREG0x20B [7] until the value becomes 1. After the value of LREG0x20B [7] becomes 1, LREG0x20B [3:0], LREG0x20A, LREG0x209 form a 20-bit value C. Then the period of the sleep clock ($P_{\text{sleepclock}}$) can be calculated by the following equation:

$$P_{\text{sleepclock}} = \frac{62.5 \times C}{16} (\text{ns})$$

If the sleep clock frequency is higher than the expected value, user can configure LREG0x220 [4:0] to slow down the clock rate. The new clock period $P_{\text{sleepclock_new}}$ is obtained by the following equation:

$$P_{\text{sleepclock_new}} = P_{\text{sleepclock_ori}} \times 2^{\text{LREG0x220[4:0]}} (\text{ns})$$

- ♦ Configure WAKECNT to set the recovery time of 32MHz clock to 180 μ s

Set WAKECNT, i.e. SREG0x36 [4:3] and SREG0x35 [6:0], to $(1000 \times 180) / P_{\text{sleepclock}}$. For example, the period of the sleep clock, $P_{\text{sleepclock}}$, is 10000ns. Set SREG0x36 [4:3] and SREG0x35 [6:0] to 0x12.

Register Trigger Wake-up

User can wake the RF Transceiver up from STANDBY and DEEP_SLEEP modes by simply setting SREG0x22 [7:6] to "11".

When the RF Transceiver is woken up by Register trigger, the following steps shall be executed to complete the operation:

- Wait the RF Transceiver issues a wake-up interrupt. The related wake-up interrupt flag is stored in SREG0x31 [6].
- Turn on SPISYNC function by setting SREG0x26 [5] to 1.
- Setting the LREG0x250 [4] to 1 to turn off the on-chip DC-DC converter.

Registers associated with Power Saving Operation:

| Addr. | File Name | Bit 7 | Bit 6 | Bit 5 | Bit 4 | Bit 3 | Bit 2 | Bit 1 | Bit 0 | Value on POR |
|-------|-----------|-----------|----------|----------|----------|----------|----------|----------|----------|--------------|
| 0x0D | RXFLUSH | r | r | r | r | r | PTX | r | RXFLUSH | 0110 0000 |
| 0x22 | WAKECTL | IMMWAKE | REGWAKE | r | r | r | r | r | r | 0100 0000 |
| 0x26 | GATECLK | r | r | SPISYNC | r | r | ENTXM | r | r | 0000 0000 |
| 0x31 | ISRSTS | r | WAKEIF | r | r | RXIF | r | r | TXNIF | 0000 0000 |
| 0x35 | SLPACK | SLPACK | WAKECNT6 | WAKECNT5 | WAKECNT4 | WAKECNT3 | WAKECNT2 | WAKECNT1 | WAKECNT0 | 0000 0000 |
| 0x36 | RFCTL | r | r | r | WAKECNT8 | WAKECNT7 | RFRST | r | r | 0000 0000 |
| 0x209 | SLPCAL_0 | SLPCAL7 | SLPCAL6 | SLPCAL5 | SLPCAL4 | SLPCAL3 | SLPCAL2 | SLPCAL1 | SLPCAL0 | 0000 0000 |
| 0x20A | SLPCAL_1 | SLPCAL15 | SLPCAL14 | SLPCAL13 | SLPCAL12 | SLPCAL11 | SLPCAL10 | SLPCAL9 | SLPCAL8 | 0000 0000 |
| 0x20B | SLPCAL_2 | SLPCALRDY | r | r | SLPCALEN | SLPCAL19 | SLPCAL18 | SLPCAL17 | SLPCAL16 | 0000 0000 |
| 0x250 | RFCTRL50 | r | r | r | DCPOC | DCOPC3 | DCOPC2 | DCOPC1 | DCOPC0 | -0000 0000 |

Primary RF Transceiver TX Operation

Users activate the primary TX mode by setting SREG0x0D [2] to 1. After changing the SREG0x0D [2] value, users have to reset the RF and let RF state machine go to primary TX mode correctly. If primary TX mode is enabled, the RF Transceiver will enter power waving mode after ant packet transmits. If primary TX mode is not enabled, the RF Transceiver will switch to RX mode after any packet transmits. If ACK response is needed and primary TX mode is enabled, the RF Transceiver will enter the Power Saving Mode after ACK frame received. If no ACK frame received, the RF Transceiver will not enter the Power Saving Mode until the max time to wait for an acknowledgement frame by setting SREG0x12 [6:0].

Registers associated with Power Saving Operation:

| Addr. | File Name | Bit 7 | Bit 6 | Bit 5 | Bit 4 | Bit 3 | Bit 2 | Bit 1 | Bit 0 | Value on POR |
|-------|-----------|-------|--------|--------|--------|--------|--------|--------|---------|--------------|
| 0x0D | RXFLUSH | r | r | r | r | r | PTX | r | RXFLUSH | 0110 0000 |
| 0x12 | ACKTO | r | MATOP6 | MATOP5 | MATOP4 | MATOP3 | MATOP2 | MATOP1 | MATOP0 | 0011 1001 |

RF Transceiver Battery Monitor Operation

The RF Transceiver has Battery Monitor function and the procedure to enable the Battery Monitor function is described as below.

- Set the battery monitor threshold value at LREG0x205 [7:4].
- Enable the battery monitor by setting the LREG0x206 [3] to the value 1.
- Read the battery-low indicator at SREG0x34 [5]. If this bit is set, it means that the supply voltage is lower than the battery monitor threshold specified by LREG0x205 [7:4].

Registers associated with Power Saving Operation:

| Addr. | File Name | Bit 7 | Bit 6 | Bit 5 | Bit 4 | Bit 3 | Bit 2 | Bit 1 | Bit 0 | Value on POR |
|-------|-----------|--------|--------|---------|---------|-------|-------|-------|---------|--------------|
| 0x34 | BATRXF | r | r | BATIND | r | r | r | RDF1 | RXFIFO2 | 0000 0000 |
| 0x205 | RFCTRL5 | BATTH3 | BATTH2 | BATTH1 | BATTH0 | r | r | r | r | 0000 0000 |
| 0x206 | RFCTRL6 | TXFBW1 | TXFBW0 | 32MXCO1 | 32MXCO0 | BATEN | r | r | r | 1111 0000 |

RF Transceiver Register Definitions

The Memory of the RF Transceiver is categorized into two kinds of addressing mode, known as Short Addressing Registers and Long Addressing Registers. Each of the Register definition is described in the following sections.

Legends of RF Transceiver Register Types

| Register Type | Description |
|---------------|--|
| R/W | Read/Write register |
| WT | Write 1 to trigger register, automatically cleared by hardware |
| RC | Read to clear register |
| R | Read-only register |
| R/W1C | Read/Write "1" to clear register |

RF Transceiver Short Addressing Registers (SREG0x00~SREG0x3F)

| | | | | | | | |
|------|---------|------|--------|------|----------|------|--------|
| 0x00 | RXMCR | 0x12 | ACKTO | 0x22 | WAKECTL | 0x30 | RXSR |
| 0x03 | AUINFL | 0x17 | PACON | 0x24 | TXSR | 0x31 | ISRSTS |
| 0x04 | AUINFH | 0x18 | TXCON | 0x26 | GATECLK | 0x32 | INTMSK |
| 0x05 | DADR_0 | 0x1B | TXTRIG | 0x2A | SOFRST | 0x34 | BATRXF |
| 0x06 | DADR_1 | | — | 0x2E | TXPEMISP | 0x35 | SLPACK |
| 0x07 | DADR_2 | | — | | — | 0x36 | RFCTL |
| 0x08 | DADR_3 | | — | | — | 0x38 | BBREG0 |
| 0x0D | RXFLUSH | | — | | — | | — |

- SREG0x00 - RXMCR: Receive MAC Control Register

| Bit | Bit 7 | Bit 6 | Bit 5 | Bit 4 | Bit 3 | Bit 2 | Bit 1 | Bit 0 |
|------|-------|-------|----------|-------|-------|-------|-------|-------|
| Name | — | — | NOACKRSP | — | — | — | — | — |
| Type | R | R | R/W | R | R | R | R | R |
| POR | 0 | 0 | 0 | 0 | 0 | 0 | 0 | 0 |

Bit 7~6 Reserved: maintain as "0b00"

Bit 5 **NOACKRSP**: Automatic Acknowledgement Response
0: (default) enables automatic acknowledgement response
1: disables automatic acknowledgement response

Bit 4~0 Reserved: maintain as "0b00000"

- SREG0x03 - AUINFL: Acknowledgement User Information Low Byte

| Bit | Bit 7 | Bit 6 | Bit 5 | Bit 4 | Bit 3 | Bit 2 | Bit 1 | Bit 0 |
|------|--------|--------|--------|--------|--------|--------|--------|--------|
| Name | AUINF7 | AUINF6 | AUINF5 | AUINF4 | AUINF3 | AUINF2 | AUINF1 | AUINF0 |
| Type | R/W | R/W | R/W | R/W | R/W | R/W | R/W | R/W |
| POR | 0 | 0 | 0 | 0 | 0 | 0 | 0 | 0 |

Bit 7~0 **AUINF [7:0]**: 16-bit User Information of Acknowledgement frame Low Byte.

- SREG0x04 - AUINFH: Acknowledgement User Information High Byte

| Bit | Bit 7 | Bit 6 | Bit 5 | Bit 4 | Bit 3 | Bit 2 | Bit 1 | Bit 0 |
|------|---------|---------|---------|---------|---------|---------|--------|--------|
| Name | AUINF15 | AUINF14 | AUINF13 | AUINF12 | AUINF11 | AUINF10 | AUINF9 | AUINF8 |
| Type | R/W | R/W | R/W | R/W | R/W | R/W | R/W | R/W |
| POR | 0 | 0 | 0 | 0 | 0 | 0 | 0 | 0 |

Bit 7~0 **AUINF [15:8]**: 16-bit User Information of Acknowledgement frame High Byte.

- SREG0x05 - DADR_0: Device Address 0

| Bit | Bit 7 | Bit 6 | Bit 5 | Bit 4 | Bit 3 | Bit 2 | Bit 1 | Bit 0 |
|------|-------|-------|-------|-------|-------|-------|-------|-------|
| Name | DADR7 | DADR6 | DADR5 | DADR4 | DADR3 | DADR2 | DADR1 | DADR0 |
| Type | R/W | R/W | R/W | R/W | R/W | R/W | R/W | R/W |
| POR | 0 | 0 | 0 | 0 | 0 | 0 | 0 | 0 |

Bit 7~0 **DADR [7:0]**: 32-bit Address of the RF Transceiver.

• SREG0x06 - DADR_1: Device Address 1

| Bit | Bit 7 | Bit 6 | Bit 5 | Bit 4 | Bit 3 | Bit 2 | Bit 1 | Bit 0 |
|------|--------|--------|--------|--------|--------|--------|-------|-------|
| Name | DADR15 | DADR14 | DADR13 | DADR12 | DADR11 | DADR10 | DADR9 | DADR8 |
| Type | R/W | R/W | R/W | R/W | R/W | R/W | R/W | R/W |
| POR | 0 | 0 | 0 | 0 | 0 | 0 | 0 | 0 |

Bit 7~0 **DADR [15:8]:** 32-bit Address of the RF Transceiver

• SREG0x07 - DADR_2: Device Address 2

| Bit | Bit 7 | Bit 6 | Bit 5 | Bit 4 | Bit 3 | Bit 2 | Bit 1 | Bit 0 |
|------|--------|--------|--------|--------|--------|--------|--------|--------|
| Name | DADR23 | DADR22 | DADR21 | DADR20 | DADR19 | DADR18 | DADR17 | DADR16 |
| Type | R/W | R/W | R/W | R/W | R/W | R/W | R/W | R/W |
| POR | 0 | 0 | 0 | 0 | 0 | 0 | 0 | 0 |

Bit 7~0 **DADR [23:16]:** 32-bit Address of the RF Transceiver.

• SREG0x08 - DADR_3: Device Address 3

| Bit | Bit 7 | Bit 6 | Bit 5 | Bit 4 | Bit 3 | Bit 2 | Bit 1 | Bit 0 |
|------|--------|--------|--------|--------|--------|--------|--------|--------|
| Name | DADR31 | DADR30 | DADR29 | DADR28 | DADR27 | DADR26 | DADR25 | DADR24 |
| Type | R/W | R/W | R/W | R/W | R/W | R/W | R/W | R/W |
| POR | 0 | 0 | 0 | 0 | 0 | 0 | 0 | 0 |

Bit 7~0 **DADR [31:24]:** 32-bit Address of the RF Transceiver

• SREG0x0D - RXFLUSH: Receive FIFO Flush

| Bit | Bit 7 | Bit 6 | Bit 5 | Bit 4 | Bit 3 | Bit 2 | Bit 1 | Bit 0 |
|------|-------|-------|-------|-------|-------|-------|-------|---------|
| Name | — | — | — | — | — | PTX | — | RXFLUSH |
| Type | R | R | R | R | R | R/W | R | WT |
| POR | 0 | 1 | 1 | 0 | 0 | 0 | 0 | 0 |

Bit 7 Reserved: maintain as "0b0"

Bit 6-5 Reserved: maintain as "0b11"

Bit 4-3 Reserved: maintain as "0b00"

Bit 2 **PTX:** Primary TX mode enable (1)

1: primary TX mode

0: primary RX mode (default)

Note: RF reset, SREG0x36 [2], is needed after switching between PTX and PRX modes

Bit 1 Reserved: maintain as "0b0"

Bit 0 **RXFLUSH:** Flush the RX FIFO

1: Flush RX FIFO. RX FIFO data is not modified. If Ping-pong FIFO is enabled

(SREG0x34 [0] =1), both FIFOs are flushed at the same time. Bit is automatically cleared to

"0" by hardware.

• SREG0x12 - ACKTO: Acknowledgement Timeout Period

| Bit | Bit 7 | Bit 6 | Bit 5 | Bit 4 | Bit 3 | Bit 2 | Bit 1 | Bit 0 |
|------|-------|--------|--------|--------|--------|--------|--------|--------|
| Name | — | MATOP6 | MATOP5 | MATOP4 | MATOP3 | MATOP2 | MATOP1 | MATOP0 |
| Type | R | R/W | R/W | R/W | R/W | R/W | R/W | R/W |
| POR | 0 | 0 | 1 | 1 | 1 | 0 | 0 | 1 |

Bit 7 Reserved: maintain as "0b0"

Bit 6~0 **MATOP [6:0]:** Maximum Acknowledgement Timeout Period
 0000000: 0 (default)
 0000001: 1
 0000010: 2
 :
 0111001: 57
 :
 1111111: 127

• SREG0x17 - PACON: Power Amplifier Control Register

| Bit | Bit 7 | Bit 6 | Bit 5 | Bit 4 | Bit 3 | Bit 2 | Bit 1 | Bit 0 |
|------|-------|-------|-------|---------|---------|---------|---------|-------|
| Name | — | — | — | PAONTS3 | PAONTS2 | PAONTS1 | PAONTS0 | — |
| Type | R | R | R | R/W | R/W | R/W | R/W | R |
| POR | 0 | 0 | 0 | 0 | 0 | 0 | 1 | 0 |

Bit 7~5 Reserved: maintain as "0b000"

Bit 4~1 **PAONTS [3:0]:** Power Amplifier Settling Time to begin packet transmission.
 0001: (default)
 0100: (optimized - do not change)

Bit 0 Reserved: maintain as "0b0"

• SREG0x18 - TXCON: Transmitter Control Register

| Bit | Bit 7 | Bit 6 | Bit 5 | Bit 4 | Bit 3 | Bit 2 | Bit 1 | Bit 0 |
|------|-------|-------|---------|---------|---------|---------|-------|-------|
| Name | — | — | TXONTS3 | TXONTS2 | TXONTS1 | TXONTS0 | — | — |
| Type | R | R | R/W | R/W | R/W | R/W | R | R |
| POR | 0 | 0 | 0 | 0 | 1 | 0 | 0 | 0 |

Bit 7~6 Reserved: maintain as "0b00"

Bit 5~2 **TXONTS [3:0]:** Transmitter Settling Time to begin packet transmission
 0010: (default)
 0101: (optimized - do not change)

Bit 1~0 Reserved: maintain as "0b00"

• SREG0x1B - TXTRIG: Transmit FIFO Control Register

| Bit | Bit 7 | Bit 6 | Bit 5 | Bit 4 | Bit 3 | Bit 2 | Bit 1 | Bit 0 |
|------|---------|---------|---------|---------|-------|----------|-------|--------|
| Name | TXRTYN3 | TXRTYN2 | TXRTYN1 | TXRTYN0 | — | TXACKREQ | — | TXTRIG |
| Type | R/W | R/W | R/W | R/W | R | R/W | R | WT |
| POR | 0 | 0 | 1 | 1 | 0 | 0 | 0 | 0 |

Bit 7-4 **TXRTYN [3:0]:** Maximum TX Retry Times
 0000: 0
 :
 0011: 3 (default)
 :
 0101: 15

Bit 3 Reserved: maintain as "0b0"

Bit 2 **TXACKREQ:** TX FIFO Acknowledge Request bit
 1: acknowledgement packet requested
 0: no acknowledgement packet requested (default)
 Transmit a packet with Acknowledgement request. If Acknowledgement is not received, the RF Transceiver retransmits up to xx times.

Bit 1 Reserved: maintain as "0b0"

Bit 0 **TXTRIG:** Transmit Trigger bit
 1: Transmit Frame in TX FIFO. Bit is automatically cleared to "0" by hardware.

• SREG0x22 - WAKECTL: Wake-up Control Register

| Bit | Bit 7 | Bit 6 | Bit 5 | Bit 4 | Bit 3 | Bit 2 | Bit 1 | Bit 0 |
|------|---------|---------|-------|-------|-------|-------|-------|-------|
| Name | IMMWAKE | REGWAKE | — | — | — | — | — | — |
| Type | R/W | WT | R | R | R | R | R | R |
| POR | 0 | 1 | 0 | 0 | 0 | 0 | 0 | 0 |

Bit 7 **IMMWAKE:** Immediate Wake-up Mode Enable bit
 1: enable immediate Wake-up Mode
 0: disable immediate Wake-up Mode (default)

Bit 6 **REGWAKE:** Register Triggered Wake-up bit
 1: To wake the RF Transceiver up. Bit is automatically to "0" by hardware.

Bit 5-0 Reserved: maintain as "0b000000"

• SREG0x24 - TXSR: TX Status Register

| Bit | Bit 7 | Bit 6 | Bit 5 | Bit 4 | Bit 3 | Bit 2 | Bit 1 | Bit 0 |
|------|----------|----------|----------|----------|-------|-------|-------|-------|
| Name | TXRETRY3 | TXRETRY2 | TXRETRY1 | TXRETRY0 | — | — | — | TXNX |
| Type | R | R | R | R | R | R | R | R |
| POR | 0 | 0 | 0 | 0 | 0 | 0 | 0 | 0 |

Bit 7-4 **TXRETRY [3:0]:** TXFIFO Retry Times
 0000: 0 (default)
 :
 0101: 15
 TXRETRY indicates the maximum number of retries of the most recent TXFIFO transmission.

Bit 3-1 Reserved: maintain as "0b000"

Bit 0 **TXNX:** TXFIFO Normal Release Status
 1: Fail, retry count exceed
 0: Succeeded (default)

• SREG0x26 - GATECLK: Gated Clock control Register

| Bit | Bit 7 | Bit 6 | Bit 5 | Bit 4 | Bit 3 | Bit 2 | Bit 1 | Bit 0 |
|------|-------|-------|---------|-------|-------|-------|-------|-------|
| Name | — | — | SPISYNC | — | — | ENTRM | — | — |
| Type | R | R | R/W | R | R | R/W | R | R |
| POR | 0 | 0 | 0 | 0 | 0 | 0 | 0 | 0 |

- Bit 7~6 Reserved: maintain as "0b00"
- Bit 5 **SPISYNC**: SPI Interface Synchronization
1: enable (optimized - do not change)
0: disable (default)
- Bit 4~3 Reserved: maintain as "0b00"
- Bit 2 **ENTRM**: TX MAC Clock Enable Control
1: enable
0: disable (default)
- Bit 1~0 Reserved: maintain as "0b00"

• SREG0x2A - SOFTRST: Software Reset control Register

| Bit | Bit 7 | Bit 6 | Bit 5 | Bit 4 | Bit 3 | Bit 2 | Bit 1 | Bit 0 |
|------|-------|-------|-------|-------|-------|-------|-------|--------|
| Name | — | — | — | — | — | — | RSTBB | RSTMAC |
| Type | R | R | R | R | R | R | WT | WT |
| POR | 0 | 0 | 0 | 0 | 0 | 0 | 0 | 0 |

- Bit 7~2 Reserved: Maintain as "0b000000"
- Bit 1 **RSTBB**: Baseband Reset
1: reset baseband circuitry. Initialization is not needed after RSTBB reset. Bit is automatically cleared to 0 by hardware.
- Bit 0 **RSTMAC**: MAC and Short/Long Addressing Registers Reset.
1: Reset MAC circuitry and Short/Long Addressing Registers. Initialization is needed after RSTMAC reset. Bit is automatically cleared to "0" by hardware.

• SREG0x2E - TXPEMISP: Transmit Parameters Register

| Bit | Bit 7 | Bit 6 | Bit 5 | Bit 4 | Bit 3 | Bit 2 | Bit 1 | Bit 0 |
|------|--------|--------|--------|--------|-------|-------|-------|-------|
| Name | TXPET3 | TXPET2 | TXPET1 | TXPET0 | — | — | — | — |
| Type | R/W | R/W | R/W | R/W | R | R | R | R |
| POR | 0 | 1 | 1 | 1 | 0 | 1 | 0 | 1 |

- Bit 7~4 **TXPET [3:0]**: TXFIFO Retry Times.
0111: (default)
1001: (optimized - do not change)
- Bit 3~0 Reserved: maintain as "0b0101"

• SREG0x30 - RXSR: RX MAC Status Register

| Bit | Bit 7 | Bit 6 | Bit 5 | Bit 4 | Bit 3 | Bit 2 | Bit 1 | Bit 0 |
|------|----------|-------|-------|----------|----------|-------|-------|-------|
| Name | RXFFFULL | WRFF1 | — | RXFFOVFL | RXCRCERR | — | — | — |
| Type | R | R | R | R | R | R | R | R |
| POR | 0 | 0 | 0 | 0 | 0 | 0 | 0 | 0 |

- Bit 7 **RXFFFULL**: RX FIFO Full
1: RX FIFO is not available for data receiving
0: RX FIFO is available for data receiving (default)
- Bit 6 **WRFF1**: RX FIFO Status
1: Packet is ready in RX FIFO 1
0: Packet is ready in RX FIFO 0 (default)
- Bit 5 Reserved: maintain as "0b0"
- Bit 4 **RXFFOVFL**: RX FIFO Overflow
1: RX FIFO overflows
0: (default) RX FIFO not overflow
- Bit 3 **RXCRCERR**: RX CRC Error
1: RX CRC error
0: RX CRC is correct (default)
- Bit 2~0 Reserved: maintain as "0b000"

• SREG0x31 - ISRSTS: Interrupt Status Register

| Bit | Bit 7 | Bit 6 | Bit 5 | Bit 4 | Bit 3 | Bit 2 | Bit 1 | Bit 0 |
|------|-------|--------|-------|-------|-------|-------|-------|-------|
| Name | — | WAKEIF | — | — | RXIF | — | — | TXNIF |
| Type | R | RC | R | R | RC | R | R | RC |
| POR | 0 | 0 | 0 | 0 | 0 | 0 | 0 | 0 |

- Bit 7 Reserved: maintain as "0b0"
- Bit 6 **WAKEIF**: Wake-up Alert Interrupt
1: A wake-up interrupt occurred
0: No wake-up alert interrupt occurred (default)
This bit is cleared to 0 when the register is read.
- Bit 5~4 Reserved: maintain as "0b00"
- Bit 3 **RXIF**: RX FIFO Reception Interrupt
1: A RX FIFO reception interrupt occurred
0: No RX FIFO reception interrupt occurred (default)
This bit is cleared to 0 when the register is read.
- Bit 2~1 Reserved: maintain as "0b00"
- Bit 0 **TXNIF**: TX FIFO Normal Transmission Interrupt
1: TX FIFO normal transmission interrupt occurred
0: No TX FIFO normal transmission interrupt occurred (default)
This bit is cleared to "0" when the register is read.

• SREG0x32 - INTMSK: Interrupt Mask control Register

| Bit | Bit 7 | Bit 6 | Bit 5 | Bit 4 | Bit 3 | Bit 2 | Bit 1 | Bit 0 |
|------|-------|---------|-------|-------|-------|-------|-------|--------|
| Name | — | WAKEMSK | — | — | RXMSK | — | — | TXNMSK |
| Type | R | R/W | R | R | R/W | R | R | R/W |
| POR | 1 | 1 | 1 | 1 | 1 | 1 | 1 | 1 |

Bit 7 Reserved: maintain as "0b1"

Bit 6 **WAKEMSK**: Wake-up Alert Interrupt Mask
1: disable the wake-up interrupt (default)
0: enable the wake-up alert interrupt

Bit 5~4 Reserved: maintain as "0b11"

Bit 3 **RXMSK**: RX FIFO Reception Interrupt Mask
1: disable the RX FIFO reception interrupt (default)
0: enable the RX FIFO reception interrupt

Bit 2~1 Reserved: maintain as "0b11"

Bit 0 **TXNMSK**: TX FIFO Normal Transmission Interrupt Mask
1: disable the TX FIFO Normal Transmission interrupt (default)
0: enable the TX FIFO Normal Transmission interrupt

• SREG0x34 - BATRXF: Battery and RX FIFO control Register

| Bit | Bit 7 | Bit 6 | Bit 5 | Bit 4 | Bit 3 | Bit 2 | Bit 1 | Bit 0 |
|------|-------|-------|--------|-------|-------|-------|-------|---------|
| Name | — | — | BATIND | — | — | — | RDF1 | RXFIFO2 |
| Type | R | R | R | R | R | R | R | R/W |
| POR | 0 | 0 | 0 | 0 | 0 | 0 | 0 | 0 |

Bit 7~6 Reserved: Maintain as "0b00"

Bit 5 **BATIND**: Battery Low Indicator
1: battery voltage is lower than the threshold voltage specified by the LREG0x205 [7:4].
0: battery voltage is higher than the threshold voltage specified by the LREG0x205 [7:4] (default)

Bit 4~2 Reserved: Maintain as "0b000"

Bit 1 **RDF1**: RX FIFO Selected to Read
1: read data from RX FIFO 1
0: read data from RX FIFO 0 (default)

Bit 0 **RXFIFO2**: RX Ping-Pong FIFO Enable Control
1: enable the RX Ping-Pong FIFOs
0: disable the RX Ping-Pong FIFOs (default)

• SREG0x35 - SLPACK: Sleep Acknowledgement and Wake-up Counter Register

| Bit | Bit 7 | Bit 6 | Bit 5 | Bit 4 | Bit 3 | Bit 2 | Bit 1 | Bit 0 |
|------|--------|----------|----------|----------|----------|----------|----------|----------|
| Name | SLPACK | WAKECNT6 | WAKECNT5 | WAKECNT4 | WAKECNT3 | WAKECNT2 | WAKECNT1 | WAKECNT0 |
| Type | WT | R/W | R/W | R/W | R/W | R/W | R/W | R/W |
| POR | 0 | 0 | 0 | 0 | 0 | 0 | 0 | 0 |

Bit 7 **SLPACK**: Sleep Acknowledgement
Place the RF Transceiver to Power Saving Mode. bit is automatically cleared to 0 by hardware.

Bit 6~0 **WAKECNT [6:0]**: System Clock Recovery Time
0000000: (default).
WAKECNT is a 9-bit value. The WAKECNT [8:7] bits are located in SREG0x36 [4:3].

• SREG0x36 - RFCTL: RF Mode Control Register

| Bit | Bit 7 | Bit 6 | Bit 5 | Bit 4 | Bit 3 | Bit 2 | Bit 1 | Bit 0 |
|------|-------|-------|-------|----------|----------|-------|-------|-------|
| Name | — | — | — | WAKECNT8 | WAKECNT7 | RFRST | — | — |
| Type | R | R | R | R/W | R/W | R/W | R | R |
| POR | 0 | 0 | 0 | 0 | 0 | 0 | 0 | 0 |

Bit 7~5 Reserved: Maintain as "0b000"

Bit 4~3 **WAKECNT [8:7]**: System Clock Recovery Time
00: (default).

WAKECNT is a 9-bit value. The WAKECNT [6:0] bits are located in SREG0x35 [6:0].

Bit 2 **RFRST**: RF State Machine Reset.
1: Hold RF state machine in Reset state
0: Normal operation of RF state machine (default)

Perform RF reset by setting RFRST to "1" and then setting RFRST to "0". Delay at least 192μs after performing to allow RF circuitry to calibrate.

Bit 1~0 Reserved: Maintain as "0b00"

• SREG0x38 - BBREG0: Baseband Register

| Bit | Bit 7 | Bit 6 | Bit 5 | Bit 4 | Bit 3 | Bit 2 | Bit 1 | Bit 0 |
|------|-------|-------|-------|-------|-------|-------|-------|-------|
| Name | — | — | — | — | — | — | — | TURBO |
| Type | R | R | R | R | R | R | R | R/W |
| POR | 1 | 0 | 0 | 0 | 0 | 0 | 0 | 1 |

Bit 7~1 Reserved: Maintain as "0b1000000"

Bit 0 **TURBO**: Turbo Mode Select
1: 1M bps Turbo Mode (default)
0: 250k bps Normal Mode

RF Transceiver Long Addressing Registers (LREG0x200~LREG0x27F)

| | | | | | | | |
|-------|----------|-------|----------|-------|----------|-------|----------|
| 0x200 | RFCTRL0 | 0x211 | IRQCTL | 0x250 | RFCTRL50 | 0x273 | RFCTRL73 |
| 0x201 | RFCTRL1 | 0x22F | TESTMODE | 0x251 | RFCTRL51 | 0x274 | RFCTRL74 |
| 0x202 | RFCTRL2 | 0x23C | — | 0x252 | RFCTRL52 | 0x275 | RFCTRL75 |
| 0x203 | _RFCTRL3 | 0x23D | GPIODIR | 0x253 | RFCTRL53 | 0x276 | RFCTRL76 |
| 0x204 | RFCTRL4 | 0x23E | GPIO | 0x254 | RFCTRL54 | 0x277 | RFCTRL77 |
| 0x205 | RFCTRL5 | | — | 0x259 | RFCTRL59 | | — |
| 0x206 | RFCTRL6 | | — | | — | | — |
| 0x207 | RFCTRL7 | | — | | — | | — |
| 0x208 | RFCTRL8 | | — | | — | | — |
| 0x209 | SLPCAL_0 | | — | | — | | — |
| 0x20A | SLPCAL_1 | | — | | — | | — |
| 0x20B | SLPCAL_2 | | — | | — | | — |

• LREG0x200 - RFCTRL0: RF Control Register 0

| Bit | Bit 7 | Bit 6 | Bit 5 | Bit 4 | Bit 3 | Bit 2 | Bit 1 | Bit 0 |
|------|-----------|-----------|-----------|-----------|-------|-------|-------|-------|
| Name | CHANNEL 3 | CHANNEL 2 | CHANNEL 1 | CHANNEL 0 | — | — | — | — |
| Type | R/W | R/W | R/W | R/W | R | R | R | R |
| POR | 0 | 0 | 0 | 0 | 0 | 0 | 0 | 1 |

Bit 7~4 **CHANNEL [3:0]:** Channel Number. IEEE 802.15.4 2.4GHz band channels (11~26)

| | |
|-------------------------------------|---------------------------|
| 0000: channel 11, 2405MHz (default) | 1000: channel 19, 2445MHz |
| 0001: channel 12, 2410MHz | 1001: channel 20, 2450MHz |
| 0010: channel 13, 2415MHz | 1010: channel 21, 2455MHz |
| 0011: channel 14, 2420MHz | 1011: channel 22, 2460MHz |
| 0100: channel 15, 2425MHz | 1100: channel 23, 2465MHz |
| 0101: channel 16, 2430MHz | 1101: channel 24, 2470MHz |
| 0110: channel 17, 2435MHz | 1110: channel 25, 2475MHz |
| 0111: channel 18, 2440MHz | 1111: channel 26, 2480MHz |

Bit 3~0 Reserved: Maintain as "0b0001"

• LREG0x201 - RFCTRL1: RF Control Register 1

| Bit | Bit 7 | Bit 6 | Bit 5 | Bit 4 | Bit 3 | Bit 2 | Bit 1 | Bit 0 |
|------|-------|-------|-------|-------|-------|-------|--------|--------|
| Name | — | — | — | — | — | — | VCORX1 | VCORX0 |
| Type | R | R | R | R | R | R | R/W | R/W |
| POR | 0 | 0 | 0 | 0 | 0 | 0 | 0 | 1 |

Bit 7~2 Reserved: Maintain as "0b000000"

Bit 1~0 **VCORX [1:0]:** RX VC
01: (default)
10: (optimized - do not change)

• LREG0x202 - RFCTRL2: RF Control Register 2

| Bit | Bit 7 | Bit 6 | Bit 5 | Bit 4 | Bit 3 | Bit 2 | Bit 1 | Bit 0 |
|------|-------|---------|---------|-------|-------|-------|-------|-------|
| Name | — | RXFC0-1 | RXFC0-0 | — | — | — | — | — |
| Type | R | R/W | R/W | R | R | R | R | R |
| POR | 1 | 0 | 0 | 0 | 0 | 0 | 0 | 0 |

Bit 7 Reserved: Maintain as "0b1"

Bit 6~5 **RXFC0 [1:0]:** RX Filter Control 0.
00: (default)
11: (optimized - do not change)

Bit 4~0 Reserved: Maintain as "0b00000"

• LREG0x203 - RFCTRL3: RF Control Register 3

| Bit | Bit 7 | Bit 6 | Bit 5 | Bit 4 | Bit 3 | Bit 2 | Bit 1 | Bit 0 |
|------|-------|-------|-------|-------|-------|-------|-------|-------|
| Name | TXGB4 | TXGB3 | TXGB2 | TXGB1 | TXGB0 | — | — | — |
| Type | R/W | R/W | R/W | R/W | R/W | R | R | R |
| POR | 0 | 0 | 0 | 0 | 0 | 0 | 0 | 0 |

Bit 7-3

TXGB [4:0]: TX Gain Control in dB. Gain step is monotonic and nonlinear with gain resolution of 0.1 ~ 0.5 dB. Gain Resolution is variable between chips.

| | |
|------------------------|-----------------|
| 00000: 0 dBm (default) | 10000: -3.1 dBm |
| 00001: -0.1 dBm | 10001: -3.3 dBm |
| 00010: -0.3 dBm | 10010: -3.6 dBm |
| 00011: -0.6 dBm | 10011: -3.8 dBm |
| 00100: -0.9 dBm | 10100: -4.2 dBm |
| 00101: -1.1 dBm | 10101: -4.4 dBm |
| 00110: -1.2 dBm | 10110: -4.7 dBm |
| 00111: -1.3 dBm | 10111: -5.0 dBm |
| 01000: -1.4 dBm | 11000: -5.3 dBm |
| 01001: -1.5 dBm | 11001: -5.7 dBm |
| 01010: -1.7 dBm | 11010: -6.2 dBm |
| 01011: -2.0 dBm | 11011: -6.5 dBm |
| 01100: -2.2 dBm | 11100: -6.9 dBm |
| 01101: -2.4 dBm | 11101: -7.4 dBm |
| 01110: -2.6 dBm | 11110: -7.9 dBm |
| 01111: -2.8 dBm | 11111: -8.3 dBm |

TX Output Power Configuration Summary table:

| TX Output Power Register Control | | | |
|----------------------------------|------------------|-----------------|-----------------|
| LREG0x253 [3:0] | LREG0x274 [7:0] | LREG0x203 [7:3] | TX Output Power |
| 00 | C6 for DC-DC OFF | 00000 | 0 dBm |
| | | 00001 | -0.1 dBm |
| | | 00010 | -0.3 dBm |
| | | 00011 | -0.6 dBm |
| | | 00100 | -0.9 dBm |
| | | 00101 | -1.1 dBm |
| | | 00110 | -1.2 dBm |
| | | 00111 | -1.3 dBm |
| | | 01000 | -1.4 dBm |
| | | 01001 | -1.5 dBm |
| | | 01010 | -1.7 dBm |
| | | 01011 | -2.0 dBm |
| | | 01100 | -2.2 dBm |
| | | 01101 | -2.4 dBm |
| | | 01110 | -2.6 dBm |
| | | 01111 | -2.8 dBm |
| | | 10000 | -3.1 dBm |
| | | 10001 | -3.3 dBm |
| | | 10010 | -3.6 dBm |
| | | 10011 | -3.8 dBm |
| 10100 | -4.2 dBm | | |
| 10101 | -4.4 dBm | | |
| 10110 | -4.7 dBm | | |
| 10111 | -5.0 dBm | | |

| TX Output Power Register Control | | | |
|----------------------------------|------------------|-----------------|-----------------|
| LREG0x253 [3:0] | LREG0x274 [7:0] | LREG0x203 [7:3] | TX Output Power |
| 00 | C6 for DC-DC OFF | 11000 | -5.3 dBm |
| | | 11001 | -5.7 dBm |
| | | 11010 | -6.2 dBm |
| | | 11011 | -6.5 dBm |
| | | 11100 | -6.9 dBm |
| | | 11101 | -7.4 dBm |
| | | 11110 | -7.9 dBm |
| | | 11111 | -8.3 dBm |
| 0C | 81 | 11111 | -16 dBm |
| 0C | 09 | 11111 | -24 dBm |
| 09 | 01 | 11111 | -32 dBm |
| 08 | 01 | 11111 | -40 dBm |

Bit 2~0 Reserved: Maintain as "0b000"

• LREG0x204 - RFCTRL4: RF Control Register 4

| Bit | Bit 7 | Bit 6 | Bit 5 | Bit 4 | Bit 3 | Bit 2 | Bit 1 | Bit 0 |
|------|-------|-------|-------|-------|-------|-------|--------|--------|
| Name | — | — | — | — | — | RXFCO | RXD2O1 | RXD2O0 |
| Type | R | R | R | R | R | R/W | R/W | R/W |
| POR | 0 | 0 | 0 | 0 | 0 | 0 | 0 | 0 |

Bit 7~3 Reserved: Maintain as "0b00000"

Bit 2 **RXFCO**: RX Filter Calibration output
1: (optimized - do not change)
0: (default)

Bit 1~0 **RXD2O [1:0]**: RX Divide-by-2 option
00: (default)
10: (optimized - do not change)

• LREG0x205 - RFCTRL5: RF Control Register 5

| Bit | Bit 7 | Bit 6 | Bit 5 | Bit 4 | Bit 3 | Bit 2 | Bit 1 | Bit 0 |
|------|--------|--------|--------|--------|-------|-------|-------|-------|
| Name | BATTH3 | BATTH2 | BATTH1 | BATTH0 | — | — | — | — |
| Type | R/W | R/W | R/W | R/W | R | R | R | R |
| POR | 0 | 0 | 0 | 0 | 0 | 0 | 0 | 0 |

Bit 7~4 **BATTH [3:0]**: Battery Monitor Threshold.

| | |
|----------------------|------------|
| 0000: 1.8V (default) | 1000: 2.6V |
| 0001: 1.9V | 1001: 2.7V |
| 0010: 2.0V | 1010: 2.8V |
| 0011: 2.1V | 1011: 2.9V |
| 0100: 2.2V | 1100: 3.0V |
| 0101: 2.3V | 1101: 3.3V |
| 0110: 2.4V | 1110: 3.4V |
| 0111: 2.5V | 1111: 3.6V |

Bit 3~0 Reserved: Maintain as "0b0000"

• LREG0x206 - RFCTRL6: RF Control Register 6

| Bit | Bit 7 | Bit 6 | Bit 5 | Bit 4 | Bit 3 | Bit 2 | Bit 1 | Bit 0 |
|------|--------|--------|---------|---------|-------|-------|-------|-------|
| Name | TXFBW1 | TXFBW0 | 32MXCO1 | 32MXCO0 | BATEN | — | — | — |
| Type | R/W | R/W | R/W | R/W | R/W | R | R | R |
| POR | 1 | 1 | 1 | 1 | 0 | 0 | 0 | 0 |

- Bit 7~6 **TXFBW [1:0]:** TX Filter
 00: Optimized for 250k bps Normal Mode
 11: Optimized for 1M bps Turbo Mode
- Bit 5~4 **32MXCO [1:0]:** 32MHz Crystal Oscillator
 00: (Optimized - do not change)
 11: (default)
- Bit 3 **BATEN:** Battery Monitor Enable
 1: Enable
 0: Disable (default)
- Bit 2~0 Reserved: Maintain as "0b000"

• LREG0x207 - RFCTRL7: RF Control Register 7

| Bit | Bit 7 | Bit 6 | Bit 5 | Bit 4 | Bit 3 | Bit 2 | Bit 1 | Bit 0 |
|------|-------|-------|-------|-------|-------|-------|-------|-------|
| Name | — | — | — | RXFC2 | — | — | — | — |
| Type | R | R | R | R/W | R | R | R | R |
| POR | 0 | 0 | 0 | 0 | 0 | 0 | 0 | 0 |

- Bit 7~5 Reserved: Maintain as "0b000"
- Bit 4 **RXFC2:** RX Filter Control 2
 1: For 1M bps Turbo Mode
 0: For 250k bps Normal Mode (default)
- Bit 3~0 Reserved: Maintain as "0b0000"

• LREG0x208 - RFCTRL8: RF Control Register 8

| Bit | Bit 7 | Bit 6 | Bit 5 | Bit 4 | Bit 3 | Bit 2 | Bit 1 | Bit 0 |
|------|---------|---------|-------|-------|-------|-------|-------|-------|
| Name | TXD2CO1 | TXD2CO0 | — | — | — | — | — | — |
| Type | R/W | R/W | R | R | R | R | R | R |
| POR | 0 | 0 | 0 | 0 | 1 | 1 | 0 | 0 |

- Bit 7~6 **TXD2CO [1:0]:** TX Divide-by-2 Option
 00: (default)
 10: (Optimized - do not change)
- Bit 5~0 Reserved: Maintain as "0b001100"

• LREG0x209 - SLPCAL_0: Sleep Clock Calibration 0

| Bit | Bit 7 | Bit 6 | Bit 5 | Bit 4 | Bit 3 | Bit 2 | Bit 1 | Bit 0 |
|------|---------|---------|---------|---------|---------|---------|---------|---------|
| Name | SLPCAL7 | SLPCAL6 | SLPCAL5 | SLPCAL4 | SLPCAL3 | SLPCAL2 | SLPCAL1 | SLPCAL0 |
| Type | R/W | R/W | R/W | R/W | R/W | R/W | R/W | R/W |
| POR | 0 | 0 | 0 | 0 | 0 | 0 | 0 | 0 |

- Bit 7~0 **SLPCAL [7:0]:** Sleep Clock Calibration Counter bit 7~0
 A 20-bit calibration counter which calibrates the sleep clock. SLPCAL [19:0] indicates the time period of 16 sleep clock cycles. The unit is 62.5ns, counted by the 16MHz.

• LREG0x20A - SLPCAL_1: Sleep Clock Calibration 1

| Bit | Bit 7 | Bit 6 | Bit 5 | Bit 4 | Bit 3 | Bit 2 | Bit 1 | Bit 0 |
|------|----------|----------|----------|----------|----------|----------|---------|---------|
| Name | SLPCAL15 | SLPCAL14 | SLPCAL13 | SLPCAL12 | SLPCAL11 | SLPCAL10 | SLPCAL9 | SLPCAL8 |
| Type | R/W | R/W | R/W | R/W | R/W | R/W | R/W | R/W |
| POR | 0 | 0 | 0 | 0 | 0 | 0 | 0 | 0 |

Bit 7-0 **SLPCAL [15:8]:** Sleep Clock Calibration Counter bit 15~8
A 20-bit calibration counter which calibrates the sleep clock. SLPCAL [19:0] indicates the time period of 16 sleep clock cycles. The unit is 62.5ns, counted by the 16MHz.

• LREG0x20B - SLPCAL_2: Sleep Clock Calibration 2

| Bit | Bit 7 | Bit 6 | Bit 5 | Bit 4 | Bit 3 | Bit 2 | Bit 1 | Bit 0 |
|------|-----------|-------|-------|----------|----------|----------|----------|----------|
| Name | SLPCALRDY | — | — | SLPCALEN | SLPCAL19 | SLPCAL18 | SLPCAL17 | SLPCAL16 |
| Type | R | R | R | WT | R/W | R/W | R/W | R/W |
| POR | 0 | 0 | 0 | 0 | 0 | 0 | 0 | 0 |

Bit 7 **SLPCALRDY:** Sleep Clock Calibration Ready
1: Sleep Clock Calibration counter is ready to be read.
0: Not Ready (default)

Bit 6-5 Reserved: Maintain as "0b00"

Bit 4 **SLPCALEN:** Sleep Clock Calibration Enable
1: Starts the Sleep Clock Calibration counter. Bit is automatically cleared to "0" by hardware

Bit 3-0 **SLPCAL [19:16]:** Sleep Clock Calibration Counter bit 19~16
A 20-bit calibration counter which calibrates the sleep clock. SLPCAL [19:0] indicates the time period of 16 sleep clock cycles. The unit is 62.5ns, counted by the 16MHz.

• LREG0x211 - IRQCTRL: Interrupt Control Register

| Bit | Bit 7 | Bit 6 | Bit 5 | Bit 4 | Bit 3 | Bit 2 | Bit 1 | Bit 0 |
|------|-------|-------|-------|-------|-------|-------|--------|-------|
| Name | — | — | — | — | — | — | IRQPOL | — |
| Type | R | R | R | R | R | R | R/W | R |
| POR | 0 | 0 | 0 | 0 | 0 | 0 | 0 | 0 |

Bit 7~2 Reserved: Maintain as "0b000000"

Bit 1 **IRQPOL:** Interrupt Edge Polarity
1: Rising Edge
0: Falling Edge (default)

Bit 0 Reserved: Maintain as "0b0"

• LREG0x22F - TESTMODE: Test Mode Register

| Bit | Bit 7 | Bit 6 | Bit 5 | Bit 4 | Bit 3 | Bit 2 | Bit 1 | Bit 0 |
|------|-------|-------|-------|-------|-------|-----------|-----------|-----------|
| Name | MSPI | — | — | — | — | TESTMODE2 | TESTMODE1 | TESTMODE0 |
| Type | R/W | R | R | R | R | R/W | R/W | R/W |
| POR | 0 | 0 | 1 | 0 | 1 | 0 | 0 | 0 |

Bit 7 **MSPI: Multiple SPI Operation**

1: Enable multiple SPI Operation, SO will be High-Z state when SPI inactive
0: Single SPI Operation, SO will be low when SPI inactive (default)

Bit 6-3 Reserved: Maintain as "0b0101"

Bit 2-0 **TESTMODE [2:0]: Special Operation**

000: (default) Normal Operation
001: GPIO0, GPIO1 and GPIO2 are configured to control the external P.A., LNA and RF switch
101: Single-Tone test mode
Others: Undefined.

• LREG0x23D - GPIODIR: GPIO Pin Direction

| Bit | Bit 7 | Bit 6 | Bit 5 | Bit 4 | Bit 3 | Bit 2 | Bit 1 | Bit 0 |
|------|-------|-------|-----------|-----------|-----------|----------|----------|----------|
| Name | — | — | GDIRCTRL2 | GDIRCTRL1 | GDIRCTRL0 | GPIO2DIR | GPIO1DIR | GPIO0DIR |
| Type | R | R | R/W | R/W | R/W | R/W | R/W | R/W |
| POR | 0 | 0 | 1 | 1 | 1 | 1 | 1 | 1 |

Bit 7-6 Reserved: Maintain as "0b00"

Bit 5-3 **GDIRCTRL [2:0]: GPIO Direction Control**

000: (Optimized - do not change)
111: (default)

Bit 2 **GPIO2DIR: General Purpose I/O GPIO2 Direction**

1: Input (default)
0: Output

Bit 1 **GPIO1DIR: General Purpose I/O GPIO1 Direction**

1: Input (default)
0: Output

Bit 0 **GPIO0DIR: General Purpose I/O GPIO0 Direction**

1: Input (default)
0: Output

• LREG0x23E - GPIO: GPIO

| Bit | Bit 7 | Bit 6 | Bit 5 | Bit 4 | Bit 3 | Bit 2 | Bit 1 | Bit 0 |
|------|-------|-------|-------|-------|-------|-------|-------|-------|
| Name | — | — | — | — | — | GPIO2 | GPIO1 | GPIO0 |
| Type | R | R | R | R | R | R/W | R/W | R/W |
| POR | 0 | 0 | 0 | 0 | 0 | 0 | 0 | 0 |

Bit 7~3 Reserved: Maintain as "0b00000"

Bit 2 **GPIO2: Setting for output/Status for input of General Purpose I/O Pin GPIO2**

0: (default)

Bit 1 **GPIO1: Setting for output/Status for input of General Purpose I/O Pin GPIO1**

0: (default)

Bit 0 **GPIO0: Setting for output/Status for input of General Purpose I/O Pin GPIO0**

0: (default)

• LREG0x250 - RFCTRL50: RF Control Register 50

| Bit | Bit 7 | Bit 6 | Bit 5 | Bit 4 | Bit 3 | Bit 2 | Bit 1 | Bit 0 |
|------|-------|-------|-------|-------|--------|--------|--------|--------|
| Name | — | — | — | DCPOC | DCOPC3 | DCOPC2 | DCOPC1 | DCOPC0 |
| Type | R | R | R | R/W | R/W | R/W | R/W | R/W |
| POR | 0 | 0 | 0 | 0 | 0 | 0 | 0 | 0 |

Bit 7~5 Reserved: Maintain as "0b000"

Bit 4 **DCPOC**: DC-DC Converter Power Control
1: Enable
0: Bypass (default)

Bit 3~0 **DCOPC [3:0]**: DC-DC Converter Optimization Control
0000: (default)
0111: (Optimized - do not change)

• LREG0x251 - RFCTRL51: RF Control Register 51

| Bit | Bit 7 | Bit 6 | Bit 5 | Bit 4 | Bit 3 | Bit 2 | Bit 1 | Bit 0 |
|------|--------|--------|-------|-------|-------|-------|-------|-------|
| Name | DCOPC5 | DCOPC4 | — | — | — | — | — | — |
| Type | R/W | R/W | R/W | R/W | R | R | R | R |
| POR | 0 | 0 | 0 | 0 | 0 | 0 | 0 | 0 |

Bit 7~6 **DCOPC [5:4]**: DC-DC Converter Optimization Control
00: (default)
11: (Optimized - do not change)

Bit 5~0 Reserved: Maintain as 0b000000

• LREG0x252 - RFCTRL52: RF Control Register 52

| Bit | Bit 7 | Bit 6 | Bit 5 | Bit 4 | Bit 3 | Bit 2 | Bit 1 | Bit 0 |
|------|---------|---------|---------|---------|---------|---------|---------|----------|
| Name | SLCTRL6 | SLCTRL5 | SLCTRL4 | SLCTRL3 | SLCTRL2 | SLCTRL1 | SLCTRL0 | 32MXCTRL |
| Type | R/W | R/W | R/W | R/W | R/W | R/W | R/W | R/W |
| POR | 1 | 1 | 1 | 1 | 1 | 1 | 1 | 1 |

Bit 7~1 **SLCTRL [6:0]**: Sleep Clock Control
0000000: (Optimized - do not change)
1111111: (default)

Bit 0 **32MXCTRL**: Start-up Circuit in 32MHz Crystal Oscillator Control
1: Enable (default)
0: Disable

• LREG0x253 - RFCTRL53: RF Control Register 53

| Bit | Bit 7 | Bit 6 | Bit 5 | Bit 4 | Bit 3 | Bit 2 | Bit 1 | Bit 0 |
|------|-------|--------|-----------|--------|--------|-----------|-----------|-----------|
| Name | — | FIFOPS | DIGITALPS | P32MXE | PACEN2 | PACTRL2-2 | PACTRL2-1 | PACTRL2-0 |
| Type | R/W | R/W | R/W | R/W | R | R | R | R |
| POR | 0 | 0 | 0 | 0 | 0 | 0 | 0 | 0 |

Bit 7 Reserved: Maintain as "0b0"

Bit 6 **FIFOPS**: FIFO Power while the RF Transceiver is in Power Saving Mode
1: GND
0: VDD (default)

Bit 5 **DIGITALPS**: Digital Power while Sleep
1: GND
0: VDD (default)

Bit 4 **P32MXE**: Partial 32MHz Clock Enable
1: Enable
0: Disable (default)

Bit 3 **PACEN2**: Power Amplifier Control 2 Enable
1: Enable
0: Disable (default)

Bit 2~0 **PACTRL2-[2:0]**: Power Amplifier Control 2
000: (default)
PACTRL2 [2:0] is for 1st stage Power Amplifier current fine tuning. Please follow the TX Output Power Configuration Summary Table in LREG0x203 Register definition.

• LREG0x254 - RFCTRL54: RF Control Register 54

| Bit | Bit 7 | Bit 6 | Bit 5 | Bit 4 | Bit 3 | Bit 2 | Bit 1 | Bit 0 |
|------|--------|---------|---------|---------|---------|---------|---------|---------|
| Name | 1MCSEN | 1MCSCH6 | 1MCSCH5 | 1MCSCH4 | 1MCSCH3 | 1MCSCH2 | 1MCSCH1 | 1MCSCH0 |
| Type | R/W | R/W | R/W | R/W | R/W | R/W | R/W | R/W |
| POR | 0 | 0 | 0 | 0 | 0 | 0 | 0 | 0 |

Bit 7 **1MCSEN**: 1 MHz Channel Spacing Enable
 1: Enable. When LREG0x254 [7] = 1, RF channel can only be selected by LREG0x254 [6:0] and the setting of LREG0x200 [7:4] will not change the channel number at all.
 0: Disable (default)

Bit 6~0 **1MCSCH [6:0]**: 1 MHz Channel Spacing Channel Number
 LREG0x254 [6:0] only works when LREG0x254 [7] = 1.

| | | |
|-------------------|-------------------|--------------------|
| 0000000: 2400 MHz | 0100001: 2433 MHz | 1000010: 2466 MHz |
| 0000001: 2401 MHz | 0100010: 2434 MHz | 1000011: 2467 MHz |
| 0000010: 2402 MHz | 0100011: 2435 MHz | 1000100: 2468 MHz |
| 0000011: 2403 MHz | 0100100: 2436 MHz | 1000101: 2469 MHz |
| 0000100: 2404 MHz | 0100101: 2437 MHz | 1000110: 2470 MHz |
| 0000101: 2405 MHz | 0100110: 2438 MHz | 1000111: 2471 MHz |
| 0000110: 2406 MHz | 0100111: 2439 MHz | 1001000: 2472 MHz |
| 0000111: 2407 MHz | 0101000: 2440 MHz | 1001001: 2473 MHz |
| 0001000: 2408 MHz | 0101001: 2441 MHz | 1001010: 2474 MHz |
| 0001001: 2409 MHz | 0101010: 2442 MHz | 1001011: 2475 MHz |
| 0001010: 2410 MHz | 0101011: 2443 MHz | 1001100: 2476 MHz |
| 0001011: 2411 MHz | 0101100: 2444 MHz | 1001101: 2477 MHz |
| 0001100: 2412 MHz | 0101101: 2445 MHz | 1001110: 2478 MHz |
| 0001101: 2413 MHz | 0101110: 2446 MHz | 1001111: 2479 MHz |
| 0001110: 2414 MHz | 0101111: 2447 MHz | 1010000: 2480 MHz |
| 0001111: 2415 MHz | 0110000: 2448 MHz | 1010001: 2481 MHz |
| 0010000: 2416 MHz | 0110001: 2449 MHz | 1010010: 2482 MHz |
| 0010001: 2417 MHz | 0110010: 2450 MHz | 1010011: 2483 MHz |
| 0010010: 2418 MHz | 0110011: 2451 MHz | 1010100: 2484 MHz |
| 0010011: 2419 MHz | 0110100: 2452 MHz | 1010101: 2485 MHz |
| 0010100: 2420 MHz | 0110101: 2453 MHz | 1010110: 2486 MHz |
| 0010101: 2421 MHz | 0110110: 2454 MHz | 1010111: 2487 MHz |
| 0010110: 2422 MHz | 0110111: 2455 MHz | 1011000: 2488 MHz |
| 0010111: 2423 MHz | 0111000: 2456 MHz | 1011001: 2489 MHz |
| 0011000: 2424 MHz | 0111001: 2457 MHz | 1011010: 2490 MHz |
| 0011001: 2425 MHz | 0111010: 2458 MHz | 1011011: 2491 MHz |
| 0011010: 2426 MHz | 0111011: 2459 MHz | 1011100: 2492 MHz |
| 0011011: 2427 MHz | 0111100: 2460 MHz | 1011101: 2493 MHz |
| 0011100: 2428 MHz | 0111101: 2461 MHz | 1011110: 2494 MHz |
| 0011101: 2429 MHz | 0111110: 2462 MHz | 1011111: 2495 MHz |
| 0011110: 2430 MHz | 0111111: 2463 MHz | 1100000: Undefined |
| 0011111: 2431 MHz | 1000000: 2464 MHz | : |
| 0100000: 2432 MHz | 1000001: 2465 MHz | 1111111: Undefined |

• LREG0x259 - RFCTRL59: RF Control Register 59

| Bit | Bit 7 | Bit 6 | Bit 5 | Bit 4 | Bit 3 | Bit 2 | Bit 1 | Bit 0 |
|------|-------|-------|-------|-------|-------|-------|-------|---------|
| Name | — | — | — | — | — | — | — | PLLOPT3 |
| Type | R | R | R | R | R | R | R | R |
| POR | 0 | 0 | 0 | 0 | 0 | 0 | 0 | 0 |

Bit 7~1 Reserved: Maintain as "0b0000000"
 Bit 0 **PLLOPT3**: PLL Performance Optimization
 1: (default)
 0: (Optimized - do not change)

• LREG0x273 - RFCTRL73: RF Control Register 73

| Bit | Bit 7 | Bit 6 | Bit 5 | Bit 4 | Bit 3 | Bit 2 | Bit 1 | Bit 0 |
|------|-----------|-----------|-------|-------|---------|---------|---------|-------|
| Name | VCOTXOPT1 | VCOTXOPT0 | — | — | PLLOPT2 | PLLOPT1 | PLLOPT0 | — |
| Type | R/W | R/W | R | R | R/W | R/W | R/W | R |
| POR | 0 | 0 | 0 | 0 | 0 | 0 | 0 | 0 |

Bit 7~6 **VCOTXOPT [1:0]**: VCO for TX Optimization
 00: (default)
 01: (Optimized - do not change)
 Bit 5~4 Reserved: Maintain as "0b00"
 Bit 3~1 **PLLOPT [2:0]**: PLL Performance Optimization
 000: (default)
 111: Optimized for DC-DC Converter Bypass
 Bit 0 Reserved: Maintain as "0b0"

• LREG0x274 - RFCTRL74: RF Control Register 74

| Bit | Bit 7 | Bit 6 | Bit 5 | Bit 4 | Bit 3 | Bit 2 | Bit 1 | Bit 0 |
|------|--------|-----------|-----------|-----------|--------|-----------|-----------|-----------|
| Name | PAC0EN | PACTRL0-2 | PACTRL0-1 | PACTRL0-0 | PAC1EN | PACTRL1-2 | PACTRL1-1 | PACTRL1-0 |
| Type | R/W | R/W | R/W | R/W | R/W | R/W | R/W | R/W |
| POR | 1 | 1 | 0 | 0 | 1 | 0 | 1 | 0 |

Bit 7 **PAC0EN**: Power Amplifier Control 0 Enable
 1: Enable (default)
 0: Disable
 Bit 6~4 **PACTRL0 [2:0]**: Power Amplifier Control 0
 100: (default)
 PACTRL0 [2:0] is for 1st stage Power Amplifier current large scale control.
 Bit 3 **PAC1EN**: Power Amplifier Control 1 Enable
 1: Enable (default)
 0: Disable
 Bit 2~0 **PACTRL1 [2:0]**: Power Amplifier Control 1
 100: Optimized for DC-DC on
 110: Optimized for DC-DC off
 010: (default)
 PACTRL1 [2:0] is for 2nd stage Power Amplifier current control. Please follow the TX Output Power Configuration Summary Table in LREG0x203 Register definition.

• LREG0x275 - RFCTRL75: RF Control Register 75

| Bit | Bit 7 | Bit 6 | Bit 5 | Bit 4 | Bit 3 | Bit 2 | Bit 1 | Bit 0 |
|------|-------|-------|-------|-------|----------|----------|----------|----------|
| Name | — | — | — | — | SCLKOPT3 | SCLKOPT2 | SCLKOPT1 | SCLKOPT0 |
| Type | R | R | R | R | R/W | R/W | R/W | R/W |
| POR | 0 | 0 | 0 | 1 | 0 | 1 | 0 | 1 |

Bit 7~4 Reserved: Maintain as "0b0001"
 Bit 3~0 **SCLKOPT [3:0]**: Sleep Clock Optimization
 0011: (Optimized - do not change)
 0101: (default)

• LREG0x276 - RFCTRL76: RF Control Register 76

| Bit | Bit 7 | Bit 6 | Bit 5 | Bit 4 | Bit 3 | Bit 2 | Bit 1 | Bit 0 |
|------|-------|-------|-------|-------|-------|----------|----------|----------|
| Name | — | — | — | — | — | SCLKOPT6 | SCLKOPT5 | SCLKOPT4 |
| Type | R | R | R | R | R | R/W | R/W | R/W |
| POR | 0 | 0 | 0 | 0 | 0 | 0 | 0 | 1 |

Bit 7~3 Reserved: Maintain as "0b00000"
 Bit 2~0 **SCLKOPT [6:4]**: Sleep Clock Optimization
 111: (Optimized - do not change)
 001: (default)

• LREG0x277 - RFCTRL77: RF Control Register 77

| Bit | Bit 7 | Bit 6 | Bit 5 | Bit 4 | Bit 3 | Bit 2 | Bit 1 | Bit 0 |
|------|-------|-------|---------|---------|-----------|-----------|----------|----------|
| Name | — | — | SLPSEL1 | SLPSEL0 | SLPVCTRL1 | SLPVCTRL0 | SLPVSEL1 | SLPVSEL0 |
| Type | R | R | R/W | R/W | R/W | R/W | R/W | R/W |
| POR | 0 | 0 | 0 | 0 | 1 | 0 | 0 | 0 |

Bit 7~6 Reserved: Maintain as "0b00"
 Bit 5~4 **SLPSEL [1:0]**: Power Saving Mode Selection
 00: (default) Standby / Deep Sleep Mode
 01: Undefined
 10: Undefined
 11: Power down Mode
 Bit 3~2 **SLPVCTRL [1:0]**: Sleep Voltage Control
 00: Undefined
 01: Controlled by LREG0x27 [1:0]
 10: (default) automatically controlled by internal circuit
 11: Undefined
 Bit 1~0 **SLPVSEL [1:0]**: Sleep Voltage Selection
 00: (default - no not change)

RF Transceiver Power-down and Wake-up

The MCU and RF Transceiver are powered down independently of each other. The method of powering down the MCU is covered in the previous MCU section of the datasheet. The RF Transceiver must be powered down before the MCU is powered down. The method of powering down the RF Transceiver is mentioned in the previous Power Saving Mode section of this datasheet.

For a RF Transceiver interrupt to occur, in addition to the bits for the related enable and interrupt polarity control described in RF Transceiver Interrupt Configuration section being set, the global interrupt enable control and the related interrupt enable control bits in host MCU must also be set. If the bits related to the interrupt function are configured properly, the RF Transceiver will generate an interrupt signal on INT pin connected to the MCU I/O pin to get the attentions from MCU and then the interrupt subroutine will be serviced. If the related interrupt control bits in host MCU are not set properly, then the interrupt signal on RF Transceiver INT line will be a wake-up signal and no interrupt will be serviced.

Using the RF Transceiver Function

To use the RF Transceiver function, several important steps must be implemented to ensure that the RF Transceiver operates normally:

- The host MCU must be configured as the Master SPI. Therefore, the MCU SPI mode selection bits [M1, M0] in SPI Interface Control Register can not be set to [1, 1] as slave mode.
- Although the SPI mode selection bits [M1, M0] can be set to [0, 0], [0, 1] and [1, 0], along with the SPI clock source selection bit CKS, to force the host MCU SPI interface to operate as Master SPI with different baud rate, there are some limitations on the maximum SPI clock speed that can be selected to be suitable for the RF Transceiver slave SPI clock speed. As the maximum RF Transceiver slave SPI clock frequency is 5MHz, care must be taken for the combinations of the SPI clock source selection CKS and mode selection [M1, M0] when the system clock frequency is greater than 5MHz. For example, if the system clock operates at a frequency of 6MHz, the SPI mode selection [M1, M0] and clock source selection CKS should not be set to [0, 0] and 0. Doing so will obtain a Master SPI baud rate of 6MHz that is greater than the maximum clock frequency of the slave SPI which may result in SPI interface malfunction.

- ♦ SPI Master/Slave/Baud rate selection bits in SBCR Register

| Bit | Bit 6 | Bit 5 |
|-------|------------|-------|
| Name | M1 | M0 |
| Value | 00, 01, 10 | |

00: SPI master mode; baud rate is f_{SPI}

01: SPI master mode; baud rate is $f_{SPI}/4$

10: SPI master mode; baud rate is $f_{SPI}/16$

11: SPI slave mode → can not be used

- ♦ SPI Clock source selection bit in SBCR Register

| Bit | Bit 7 |
|-------|-------|
| Name | CKS |
| Value | 0, 1 |

0: $f_{SPI} = f_{SYS}/2$

1: $f_{SPI} = f_{SYS}$

- Since the MSB is first shifted in on SI line and shifted out on SO line for the RF Transceiver slave SPI read/write operations, the MSB/LSB selection bit MLS in MCU Master SPI SBCR register should be set to 1 for MSB shift first on SDI/SDO lines.

- ♦ SPI MSB/LSB first selection bit in SBCR Register

| Bit | Bit 5 |
|---------------|-------|
| Name | MLS |
| Setting value | 1 |

- As the RF Transceiver slave SPI timing diagram shows, the SPI data output mode selection SPI_MODE and the clock polarity selection SPI_CPOL of the master SPI should be correctly set to fit the slave SPI protocol requirement. To successfully communicate with the RF Transceiver slave SPI, the SPI_MODE and SPI_CPOL of the MCU master SPI should be set to [1, 1].

♦ SPI_MODE and SPI_CPOL setup in SPIR Register

| Bit | Bit 1 | Bit 0 |
|---------------|----------|----------|
| Name | SPI_MODE | SPI_CPOL |
| Setting value | 1 | 1 |

The relevant timing diagram for the above setting is shown in the preceding SPI Bus Timing diagram in SPI Serial Interface section.

- For the MCU master SPI to completely control the slave SPI SEN line, the MCU master SPI uses a general purpose I/O line via application program instead of the SPI \overline{SCS} line with hardware mechanism. To achieve this requirement, the software CSEN enable control bit SPI_CSEN of the Master SPI should be set to 0, then the master SPI \overline{SCS} line will lose the SCS line characteristics and be configured as a general purpose I/O line.

♦ SPI_CSEN software CSEN enable control bit in SPIR Register

| Bit | Bit 5 |
|---------------|----------|
| Name | SPI_CSEN |
| Setting value | 0 |

0: the software CSEN function is disabled and the \overline{SCS} line is configured as an I/O line

- Finally set the SPI_EN bit to 1 to ensure that the pin-shared function for other three SPI lines known as SCK, SDI and SDO are surely selected.

♦ SPI_EN software SPI interface lines enable control bit in SPIR Register

| Bit | Bit 5 |
|---------------|--------|
| Name | SPI_EN |
| Setting value | 1 |

1: the pin-shared function of the SPI interface lines is enabled.

After the above setup conditions have been implemented, the MCU can enable the SPI interface by setting the SBEN bit high. The MCU can then begin communication with the RF Transceiver using the SPI interface. The detailed MCU Master SPI functional description is provided within the SPI Serial Interface section of the MCU datasheet.

Application Circuits with RF Transceiver

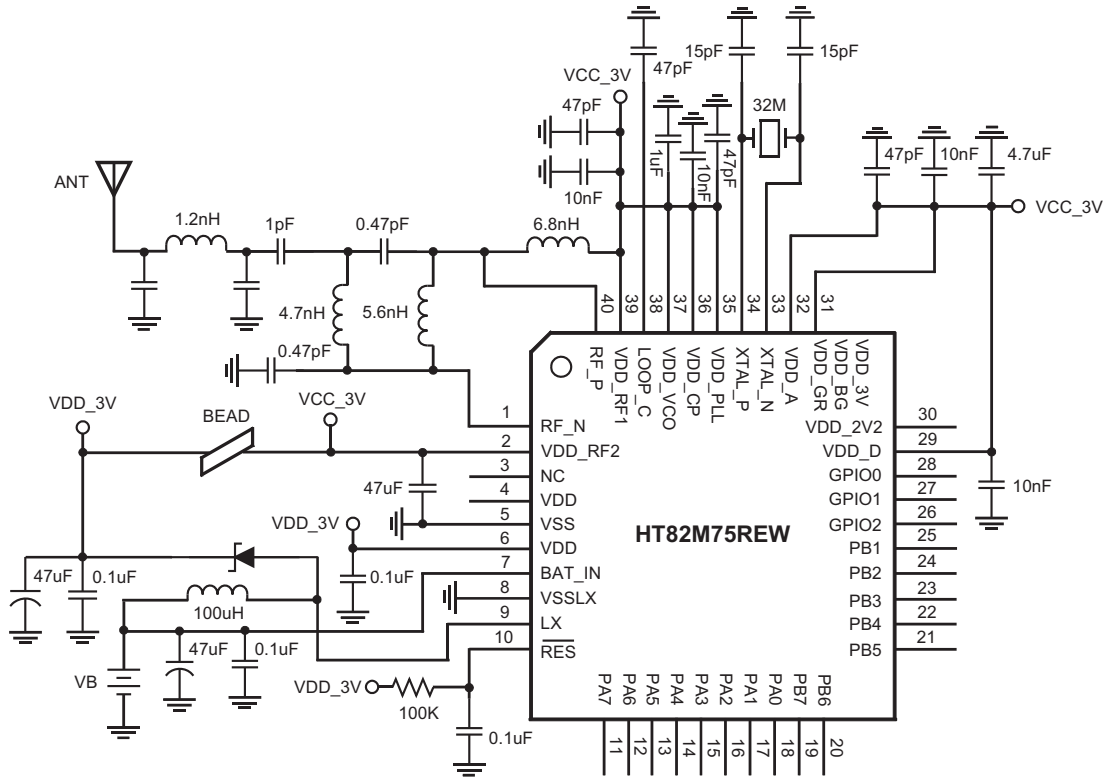

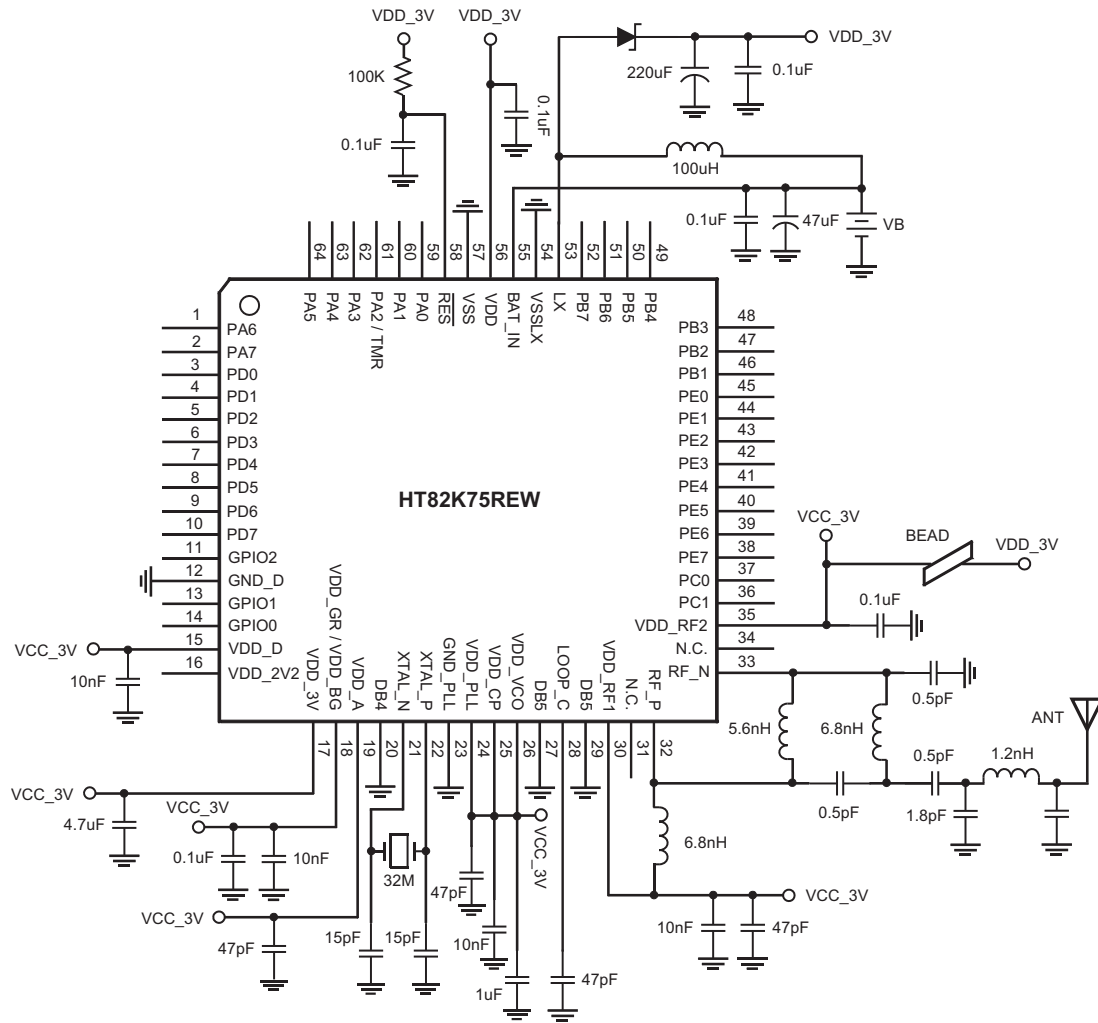

Instruction Set

Introduction

Central to the successful operation of any microcontroller is its instruction set, which is a set of program instruction codes that directs the microcontroller to perform certain operations. In the case of Holtek microcontrollers, a comprehensive and flexible set of over 60 instructions is provided to enable programmers to implement their application with the minimum of programming overheads.

For easier understanding of the various instruction codes, they have been subdivided into several functional groupings.

Instruction Timing

Most instructions are implemented within one instruction cycle. The exceptions to this are branch, call, or table read instructions where two instruction cycles are required. One instruction cycle is equal to 4 system clock cycles, therefore in the case of an 8MHz system oscillator, most instructions would be implemented within 0.5 μ s and branch or call instructions would be implemented within 1 μ s. Although instructions which require one more cycle to implement are generally limited to the JMP, CALL, RET, RETI and table read instructions, it is important to realize that any other instructions which involve manipulation of the Program Counter Low register or PCL will also take one more cycle to implement. As instructions which change the contents of the PCL will imply a direct jump to that new address, one more cycle will be required. Examples of such instructions would be "CLR PCL" or "MOV PCL, A". For the case of skip instructions, it must be noted that if the result of the comparison involves a skip operation then this will also take one more cycle, if no skip is involved then only one cycle is required.

Moving and Transferring Data

The transfer of data within the microcontroller program is one of the most frequently used operations. Making use of three kinds of MOV instructions, data can be transferred from registers to the Accumulator and vice-versa as well as being able to move specific immediate data directly into the Accumulator. One of the most important data transfer applications is to receive data from the input ports and transfer data to the output ports.

Arithmetic Operations

The ability to perform certain arithmetic operations and data manipulation is a necessary feature of most microcontroller applications. Within the Holtek microcontroller instruction set are a range of add and

subtract instruction mnemonics to enable the necessary arithmetic to be carried out. Care must be taken to ensure correct handling of carry and borrow data when results exceed 255 for addition and less than 0 for subtraction. The increment and decrement instructions INC, INCA, DEC and DECA provide a simple means of increasing or decreasing by a value of one of the values in the destination specified.

Logical and Rotate Operations

The standard logical operations such as AND, OR, XOR and CPL all have their own instruction within the Holtek microcontroller instruction set. As with the case of most instructions involving data manipulation, data must pass through the Accumulator which may involve additional programming steps. In all logical data operations, the zero flag may be set if the result of the operation is zero. Another form of logical data manipulation comes from the rotate instructions such as RR, RL, RRC and RLC which provide a simple means of rotating one bit right or left. Different rotate instructions exist depending on program requirements. Rotate instructions are useful for serial port programming applications where data can be rotated from an internal register into the Carry bit from where it can be examined and the necessary serial bit set high or low. Another application where rotate data operations are used is to implement multiplication and division calculations.

Branches and Control Transfer

Program branching takes the form of either jumps to specified locations using the JMP instruction or to a subroutine using the CALL instruction. They differ in the sense that in the case of a subroutine call, the program must return to the instruction immediately when the subroutine has been carried out. This is done by placing a return instruction RET in the subroutine which will cause the program to jump back to the address right after the CALL instruction. In the case of a JMP instruction, the program simply jumps to the desired location. There is no requirement to jump back to the original jumping off point as in the case of the CALL instruction. One special and extremely useful set of branch instructions are the conditional branches. Here a decision is first made regarding the condition of a certain data memory or individual bits. Depending upon the conditions, the program will continue with the next instruction or skip over it and jump to the following instruction. These instructions are the key to decision making and branching within the program perhaps determined by the condition of certain input switches or by the condition of internal data bits.

Bit Operations

The ability to provide single bit operations on Data Memory is an extremely flexible feature of all Holtek microcontrollers. This feature is especially useful for output port bit programming where individual bits or port pins can be directly set high or low using either the "SET [m].i" or "CLR [m].i" instructions respectively. The feature removes the need for programmers to first read the 8-bit output port, manipulate the input data to ensure that other bits are not changed and then output the port with the correct new data. This read-modify-write process is taken care of automatically when these bit operation instructions are used.

Table Read Operations

Data storage is normally implemented by using registers. However, when working with large amounts of fixed data, the volume involved often makes it inconvenient to store the fixed data in the Data Memory. To overcome this problem, Holtek microcontrollers allow an area of Program Memory to be setup as a table where data can be directly stored. A set of easy to use instructions provides the means by which this fixed data can be referenced and retrieved from the Program Memory.

Other Operations

In addition to the above functional instructions, a range of other instructions also exist such as the "HALT" instruction for Power-down operations and instructions to control the operation of the Watchdog Timer for reliable program operations under extreme electric or electromagnetic environments. For their relevant operations, refer to the functional related sections.

Instruction Set Summary

The following table depicts a summary of the instruction set categorised according to function and can be consulted as a basic instruction reference using the following listed conventions.

Table conventions:

x: Bits immediate data

m: Data Memory address

A: Accumulator

i: 0-7 number of bits

addr: Program memory address

| Mnemonic | Description | Cycles | Flag Affected |
|----------------------------------|---|-------------------|---------------|
| Arithmetic | | | |
| ADD A,[m] | Add Data Memory to ACC | 1 | Z, C, AC, OV |
| ADDM A,[m] | Add ACC to Data Memory | ¹ Note | Z, C, AC, OV |
| ADD A,x | Add immediate data to ACC | 1 | Z, C, AC, OV |
| ADC A,[m] | Add Data Memory to ACC with Carry | 1 | Z, C, AC, OV |
| ADCM A,[m] | Add ACC to Data memory with Carry | ¹ Note | Z, C, AC, OV |
| SUB A,x | Subtract immediate data from the ACC | 1 | Z, C, AC, OV |
| SUB A,[m] | Subtract Data Memory from ACC | 1 | Z, C, AC, OV |
| SUBM A,[m] | Subtract Data Memory from ACC with result in Data Memory | ¹ Note | Z, C, AC, OV |
| SBC A,[m] | Subtract Data Memory from ACC with Carry | 1 | Z, C, AC, OV |
| SBCM A,[m] | Subtract Data Memory from ACC with Carry, result in Data Memory | ¹ Note | Z, C, AC, OV |
| DAA [m] | Decimal adjust ACC for Addition with result in Data Memory | ¹ Note | C |
| Logic Operation | | | |
| AND A,[m] | Logical AND Data Memory to ACC | 1 | Z |
| OR A,[m] | Logical OR Data Memory to ACC | 1 | Z |
| XOR A,[m] | Logical XOR Data Memory to ACC | 1 | Z |
| ANDM A,[m] | Logical AND ACC to Data Memory | ¹ Note | Z |
| ORM A,[m] | Logical OR ACC to Data Memory | ¹ Note | Z |
| XORM A,[m] | Logical XOR ACC to Data Memory | ¹ Note | Z |
| AND A,x | Logical AND immediate Data to ACC | 1 | Z |
| OR A,x | Logical OR immediate Data to ACC | 1 | Z |
| XOR A,x | Logical XOR immediate Data to ACC | 1 | Z |
| CPL [m] | Complement Data Memory | ¹ Note | Z |
| CPLA [m] | Complement Data Memory with result in ACC | 1 | Z |
| Increment & Decrement | | | |
| INCA [m] | Increment Data Memory with result in ACC | 1 | Z |
| INC [m] | Increment Data Memory | ¹ Note | Z |
| DECA [m] | Decrement Data Memory with result in ACC | 1 | Z |
| DEC [m] | Decrement Data Memory | ¹ Note | Z |

| Mnemonic | Description | Cycles | Flag Affected |
|----------------------|---|-------------------|---------------|
| Rotate | | | |
| RRA [m] | Rotate Data Memory right with result in ACC | 1 | None |
| RR [m] | Rotate Data Memory right | ¹ Note | None |
| RRCA [m] | Rotate Data Memory right through Carry with result in ACC | 1 | C |
| RRC [m] | Rotate Data Memory right through Carry | ¹ Note | C |
| RLA [m] | Rotate Data Memory left with result in ACC | 1 | None |
| RL [m] | Rotate Data Memory left | ¹ Note | None |
| RLCA [m] | Rotate Data Memory left through Carry with result in ACC | 1 | C |
| RLC [m] | Rotate Data Memory left through Carry | ¹ Note | C |
| Data Move | | | |
| MOV A,[m] | Move Data Memory to ACC | 1 | None |
| MOV [m],A | Move ACC to Data Memory | ¹ Note | None |
| MOV A,x | Move immediate data to ACC | 1 | None |
| Bit Operation | | | |
| CLR [m].i | Clear bit of Data Memory | ¹ Note | None |
| SET [m].i | Set bit of Data Memory | ¹ Note | None |
| Branch | | | |
| JMP addr | Jump unconditionally | 2 | None |
| SZ [m] | Skip if Data Memory is zero | ¹ Note | None |
| SZA [m] | Skip if Data Memory is zero with data movement to ACC | ¹ note | None |
| SZ [m].i | Skip if bit i of Data Memory is zero | ¹ Note | None |
| SNZ [m].i | Skip if bit i of Data Memory is not zero | ¹ Note | None |
| SIZ [m] | Skip if increment Data Memory is zero | ¹ Note | None |
| SDZ [m] | Skip if decrement Data Memory is zero | ¹ Note | None |
| SIZA [m] | Skip if increment Data Memory is zero with result in ACC | ¹ Note | None |
| SDZA [m] | Skip if decrement Data Memory is zero with result in ACC | ¹ Note | None |
| CALL addr | Subroutine call | 2 | None |
| RET | Return from subroutine | 2 | None |
| RET A,x | Return from subroutine and load immediate data to ACC | 2 | None |
| RETI | Return from interrupt | 2 | None |
| Table Read | | | |
| TABRDC [m] | Read table (current page) to TBLH and Data Memory | 2 ^{Note} | None |
| TABRDL [m] | Read table (last page) to TBLH and Data Memory | 2 ^{Note} | None |
| Miscellaneous | | | |
| NOP | No operation | 1 | None |
| CLR [m] | Clear Data Memory | ¹ Note | None |
| SET [m] | Set Data Memory | ¹ Note | None |
| CLR WDT | Clear Watchdog Timer | 1 | TO, PDF |
| CLR WDT1 | Pre-clear Watchdog Timer | 1 | TO, PDF |
| CLR WDT2 | Pre-clear Watchdog Timer | 1 | TO, PDF |
| SWAP [m] | Swap nibbles of Data Memory | ¹ Note | None |
| SWAPA [m] | Swap nibbles of Data Memory with result in ACC | 1 | None |
| HALT | Enter power down mode | 1 | TO, PDF |

Note: 1. For skip instructions, if the result of the comparison involves a skip then two cycles are required, if no skip takes place only one cycle is required.
2. Any instruction which changes the contents of the PCL will also require 2 cycles for execution.
3. For the "CLR WDT1" and "CLR WDT2" instructions the TO and PDF flags may be affected by the execution status. The TO and PDF flags are cleared after both "CLR WDT1" and "CLR WDT2" instructions are consecutively executed. Otherwise the TO and PDF flags remain unchanged.

Instruction Definition

| | |
|-------------------|--|
| ADC A,[m] | Add Data Memory to ACC with Carry |
| Description | The contents of the specified Data Memory, Accumulator and the carry flag are added. The result is stored in the Accumulator. |
| Operation | $ACC \leftarrow ACC + [m] + C$ |
| Affected flag(s) | OV, Z, AC, C |
| ADCM A,[m] | Add ACC to Data Memory with Carry |
| Description | The contents of the specified Data Memory, Accumulator and the carry flag are added. The result is stored in the specified Data Memory. |
| Operation | $[m] \leftarrow ACC + [m] + C$ |
| Affected flag(s) | OV, Z, AC, C |
| ADD A,[m] | Add Data Memory to ACC |
| Description | The contents of the specified Data Memory and the Accumulator are added. The result is stored in the Accumulator. |
| Operation | $ACC \leftarrow ACC + [m]$ |
| Affected flag(s) | OV, Z, AC, C |
| ADD A,x | Add immediate data to ACC |
| Description | The contents of the Accumulator and the specified immediate data are added. The result is stored in the Accumulator. |
| Operation | $ACC \leftarrow ACC + x$ |
| Affected flag(s) | OV, Z, AC, C |
| ADDM A,[m] | Add ACC to Data Memory |
| Description | The contents of the specified Data Memory and the Accumulator are added. The result is stored in the specified Data Memory. |
| Operation | $[m] \leftarrow ACC + [m]$ |
| Affected flag(s) | OV, Z, AC, C |
| AND A,[m] | Logical AND Data Memory to ACC |
| Description | Data in the Accumulator and the specified Data Memory perform a bitwise logical AND operation. The result is stored in the Accumulator. |
| Operation | $ACC \leftarrow ACC \text{ "AND" } [m]$ |
| Affected flag(s) | Z |
| AND A,x | Logical AND immediate data to ACC |
| Description | Data in the Accumulator and the specified immediate data perform a bitwise logical AND operation. The result is stored in the Accumulator. |
| Operation | $ACC \leftarrow ACC \text{ "AND" } x$ |
| Affected flag(s) | Z |
| ANDM A,[m] | Logical AND ACC to Data Memory |
| Description | Data in the specified Data Memory and the Accumulator perform a bitwise logical AND operation. The result is stored in the Data Memory. |
| Operation | $[m] \leftarrow ACC \text{ "AND" } [m]$ |
| Affected flag(s) | Z |

| | |
|------------------|---|
| CALL addr | Subroutine call |
| Description | Unconditionally calls a subroutine at the specified address. The Program Counter then increments by 1 to obtain the address of the next instruction which is then pushed onto the stack. The specified address is then loaded and the program continues execution from this new address. As this instruction requires an additional operation, it is a two cycle instruction. |
| Operation | Stack ← Program Counter + 1 Program Counter ← addr |
| Affected flag(s) | None |
| CLR [m] | Clear Data Memory |
| Description | Each bit of the specified Data Memory is cleared to 0. |
| Operation | [m] ← 00H |
| Affected flag(s) | None |
| CLR [m].i | Clear bit of Data Memory |
| Description | Bit i of the specified Data Memory is cleared to 0. |
| Operation | [m].i ← 0 |
| Affected flag(s) | None |
| CLR WDT | Clear Watchdog Timer |
| Description | The TO, PDF flags and the WDT are all cleared. |
| Operation | WDT cleared TO ← 0 PDF ← 0 |
| Affected flag(s) | TO, PDF |
| CLR WDT1 | Pre-clear Watchdog Timer |
| Description | The TO, PDF flags and the WDT are all cleared. Note that this instruction works in conjunction with CLR WDT2 and must be executed alternately with CLR WDT2 to have effect. Repeatedly executing this instruction without alternately executing CLR WDT2 will have no effect. |
| Operation | WDT cleared TO ← 0 PDF ← 0 |
| Affected flag(s) | TO, PDF |
| CLR WDT2 | Pre-clear Watchdog Timer |
| Description | The TO, PDF flags and the WDT are all cleared. Note that this instruction works in conjunction with CLR WDT1 and must be executed alternately with CLR WDT1 to have effect. Repeatedly executing this instruction without alternately executing CLR WDT1 will have no effect. |
| Operation | WDT cleared TO ← 0 PDF ← 0 |
| Affected flag(s) | TO, PDF |

| | |
|------------------|--|
| CPL [m] | Complement Data Memory |
| Description | Each bit of the specified Data Memory is logically complemented (1's complement). Bits which previously contained a 1 are changed to 0 and vice versa. |
| Operation | $[m] \leftarrow \overline{[m]}$ |
| Affected flag(s) | Z |
| CPLA [m] | Complement Data Memory with result in ACC |
| Description | Each bit of the specified Data Memory is logically complemented (1's complement). Bits which previously contained a 1 are changed to 0 and vice versa. The complemented result is stored in the Accumulator and the contents of the Data Memory remain unchanged. |
| Operation | $ACC \leftarrow \overline{[m]}$ |
| Affected flag(s) | Z |
| DAA [m] | Decimal-Adjust ACC for addition with result in Data Memory |
| Description | Convert the contents of the Accumulator value to a BCD (Binary Coded Decimal) value resulting from the previous addition of two BCD variables. If the low nibble is greater than 9 or if AC flag is set, then a value of 6 will be added to the low nibble. Otherwise the low nibble remains unchanged. If the high nibble is greater than 9 or if the C flag is set, then a value of 6 will be added to the high nibble. Essentially, the decimal conversion is performed by adding 00H, 06H, 60H or 66H depending on the Accumulator and flag conditions. Only the C flag may be affected by this instruction which indicates that if the original BCD sum is greater than 100, it allows multiple precision decimal addition. |
| Operation | $[m] \leftarrow ACC + 00H$ or $[m] \leftarrow ACC + 06H$ or $[m] \leftarrow ACC + 60H$ or $[m] \leftarrow ACC + 66H$ |
| Affected flag(s) | C |
| DEC [m] | Decrement Data Memory |
| Description | Data in the specified Data Memory is decremented by 1. |
| Operation | $[m] \leftarrow [m] - 1$ |
| Affected flag(s) | Z |
| DECA [m] | Decrement Data Memory with result in ACC |
| Description | Data in the specified Data Memory is decremented by 1. The result is stored in the Accumulator. The contents of the Data Memory remain unchanged. |
| Operation | $ACC \leftarrow [m] - 1$ |
| Affected flag(s) | Z |
| HALT | Enter power down mode |
| Description | This instruction stops the program execution and turns off the system clock. The contents of the Data Memory and registers are retained. The WDT and prescaler are cleared. The power down flag PDF is set and the WDT time-out flag TO is cleared. |
| Operation | $TO \leftarrow 0$ $PDF \leftarrow 1$ |
| Affected flag(s) | TO, PDF |

| | |
|------------------|--|
| INC [m] | Increment Data Memory |
| Description | Data in the specified Data Memory is incremented by 1. |
| Operation | $[m] \leftarrow [m] + 1$ |
| Affected flag(s) | Z |
| INCA [m] | Increment Data Memory with result in ACC |
| Description | Data in the specified Data Memory is incremented by 1. The result is stored in the Accumulator. The contents of the Data Memory remain unchanged. |
| Operation | $ACC \leftarrow [m] + 1$ |
| Affected flag(s) | Z |
| JMP addr | Jump unconditionally |
| Description | The contents of the Program Counter are replaced with the specified address. Program execution then continues from this new address. As this requires the insertion of a dummy instruction while the new address is loaded, it is a two cycle instruction. |
| Operation | $Program\ Counter \leftarrow addr$ |
| Affected flag(s) | None |
| MOV A,[m] | Move Data Memory to ACC |
| Description | The contents of the specified Data Memory are copied to the Accumulator. |
| Operation | $ACC \leftarrow [m]$ |
| Affected flag(s) | None |
| MOV A,x | Move immediate data to ACC |
| Description | The immediate data specified is loaded into the Accumulator. |
| Operation | $ACC \leftarrow x$ |
| Affected flag(s) | None |
| MOV [m],A | Move ACC to Data Memory |
| Description | The contents of the Accumulator are copied to the specified Data Memory. |
| Operation | $[m] \leftarrow ACC$ |
| Affected flag(s) | None |
| NOP | No operation |
| Description | No operation is performed. Execution continues with the next instruction. |
| Operation | No operation |
| Affected flag(s) | None |
| OR A,[m] | Logical OR Data Memory to ACC |
| Description | Data in the Accumulator and the specified Data Memory perform a bitwise logical OR operation. The result is stored in the Accumulator. |
| Operation | $ACC \leftarrow ACC \text{ "OR" } [m]$ |
| Affected flag(s) | Z |

| | |
|------------------|--|
| OR A,x | Logical OR immediate data to ACC |
| Description | Data in the Accumulator and the specified immediate data perform a bitwise logical OR operation. The result is stored in the Accumulator. |
| Operation | ACC ← ACC "OR" x |
| Affected flag(s) | Z |
| ORM A,[m] | Logical OR ACC to Data Memory |
| Description | Data in the specified Data Memory and the Accumulator perform a bitwise logical OR operation. The result is stored in the Data Memory. |
| Operation | [m] ← ACC "OR" [m] |
| Affected flag(s) | Z |
| RET | Return from subroutine |
| Description | The Program Counter is restored from the stack. Program execution continues at the restored address. |
| Operation | Program Counter ← Stack |
| Affected flag(s) | None |
| RET A,x | Return from subroutine and load immediate data to ACC |
| Description | The Program Counter is restored from the stack and the Accumulator loaded with the specified immediate data. Program execution continues at the restored address. |
| Operation | Program Counter ← Stack ACC ← x |
| Affected flag(s) | None |
| RETI | Return from interrupt |
| Description | The Program Counter is restored from the stack and the interrupts are re-enabled by setting the EMI bit. EMI is the master interrupt global enable bit. If an interrupt was pending when the RETI instruction is executed, the pending Interrupt routine will be processed before returning to the main program. |
| Operation | Program Counter ← Stack EMI ← 1 |
| Affected flag(s) | None |
| RL [m] | Rotate Data Memory left |
| Description | The contents of the specified Data Memory are rotated left by 1 bit with bit 7 rotated into bit 0. |
| Operation | [m].(i+1) ← [m].i; (i = 0~6) [m].0 ← [m].7 |
| Affected flag(s) | None |
| RLA [m] | Rotate Data Memory left with result in ACC |
| Description | The contents of the specified Data Memory are rotated left by 1 bit with bit 7 rotated into bit 0. The rotated result is stored in the Accumulator and the contents of the Data Memory remain unchanged. |
| Operation | ACC.(i+1) ← [m].i; (i = 0~6) ACC.0 ← [m].7 |
| Affected flag(s) | None |

| | |
|------------------|---|
| RLC [m] | Rotate Data Memory left through Carry |
| Description | The contents of the specified Data Memory and the carry flag are rotated left by 1 bit. Bit 7 replaces the Carry bit and the original carry flag is rotated into bit 0. |
| Operation | $[m].(i+1) \leftarrow [m].i; (i = 0\sim6)$ $[m].0 \leftarrow C$ $C \leftarrow [m].7$ |
| Affected flag(s) | C |
| RLCA [m] | Rotate Data Memory left through Carry with result in ACC |
| Description | Data in the specified Data Memory and the carry flag are rotated left by 1 bit. Bit 7 replaces the Carry bit and the original carry flag is rotated into the bit 0. The rotated result is stored in the Accumulator and the contents of the Data Memory remain unchanged. |
| Operation | $ACC.(i+1) \leftarrow [m].i; (i = 0\sim6)$ $ACC.0 \leftarrow C$ $C \leftarrow [m].7$ |
| Affected flag(s) | C |
| RR [m] | Rotate Data Memory right |
| Description | The contents of the specified Data Memory are rotated right by 1 bit with bit 0 rotated into bit 7. |
| Operation | $[m].i \leftarrow [m].(i+1); (i = 0\sim6)$ $[m].7 \leftarrow [m].0$ |
| Affected flag(s) | None |
| RRA [m] | Rotate Data Memory right with result in ACC |
| Description | Data in the specified Data Memory and the carry flag are rotated right by 1 bit with bit 0 rotated into bit 7. The rotated result is stored in the Accumulator and the contents of the Data Memory remain unchanged. |
| Operation | $ACC.i \leftarrow [m].(i+1); (i = 0\sim6)$ $ACC.7 \leftarrow [m].0$ |
| Affected flag(s) | None |
| RRC [m] | Rotate Data Memory right through Carry |
| Description | The contents of the specified Data Memory and the carry flag are rotated right by 1 bit. Bit 0 replaces the Carry bit and the original carry flag is rotated into bit 7. |
| Operation | $[m].i \leftarrow [m].(i+1); (i = 0\sim6)$ $[m].7 \leftarrow C$ $C \leftarrow [m].0$ |
| Affected flag(s) | C |
| RRCA [m] | Rotate Data Memory right through Carry with result in ACC |
| Description | Data in the specified Data Memory and the carry flag are rotated right by 1 bit. Bit 0 replaces the Carry bit and the original carry flag is rotated into bit 7. The rotated result is stored in the Accumulator and the contents of the Data Memory remain unchanged. |
| Operation | $ACC.i \leftarrow [m].(i+1); (i = 0\sim6)$ $ACC.7 \leftarrow C$ $C \leftarrow [m].0$ |
| Affected flag(s) | C |

| | |
|-------------------|---|
| SBC A,[m] | Subtract Data Memory from ACC with Carry |
| Description | The contents of the specified Data Memory and the complement of the carry flag are subtracted from the Accumulator. The result is stored in the Accumulator. Note that if the result of subtraction is negative, the C flag will be cleared to 0, otherwise if the result is positive or zero, the C flag will be set to 1. |
| Operation | $ACC \leftarrow ACC - [m] - \bar{C}$ |
| Affected flag(s) | OV, Z, AC, C |
| SBCM A,[m] | Subtract Data Memory from ACC with Carry and result in Data Memory |
| Description | The contents of the specified Data Memory and the complement of the carry flag are subtracted from the Accumulator. The result is stored in the Data Memory. Note that if the result of subtraction is negative, the C flag will be cleared to 0, otherwise if the result is positive or zero, the C flag will be set to 1. |
| Operation | $[m] \leftarrow ACC - [m] - \bar{C}$ |
| Affected flag(s) | OV, Z, AC, C |
| SDZ [m] | Skip if decrement Data Memory is 0 |
| Description | The contents of the specified Data Memory are first decremented by 1. If the result is 0 the following instruction is skipped. As this requires the insertion of a dummy instruction while the next instruction is fetched, it is a two cycle instruction. If the result is not 0 the program proceeds with the following instruction. |
| Operation | $[m] \leftarrow [m] - 1$ Skip if $[m] = 0$ |
| Affected flag(s) | None |
| SDZA [m] | Skip if decrement Data Memory is zero with result in ACC |
| Description | The contents of the specified Data Memory are first decremented by 1. If the result is 0, the following instruction is skipped. The result is stored in the Accumulator but the specified Data Memory contents remain unchanged. As this requires the insertion of a dummy instruction while the next instruction is fetched, it is a two cycle instruction. If the result is not 0, the program proceeds with the following instruction. |
| Operation | $ACC \leftarrow [m] - 1$ Skip if $ACC = 0$ |
| Affected flag(s) | None |
| SET [m] | Set Data Memory |
| Description | Each bit of the specified Data Memory is set to 1. |
| Operation | $[m] \leftarrow FFH$ |
| Affected flag(s) | None |
| SET [m].i | Set bit of Data Memory |
| Description | Bit i of the specified Data Memory is set to 1. |
| Operation | $[m].i \leftarrow 1$ |
| Affected flag(s) | None |

| | |
|-------------------|--|
| SIZ [m] | Skip if increment Data Memory is 0 |
| Description | The contents of the specified Data Memory are first incremented by 1. If the result is 0, the following instruction is skipped. As this requires the insertion of a dummy instruction while the next instruction is fetched, it is a two cycle instruction. If the result is not 0 the program proceeds with the following instruction. |
| Operation | $[m] \leftarrow [m] + 1$ Skip if $[m] = 0$ |
| Affected flag(s) | None |
| SIZA [m] | Skip if increment Data Memory is zero with result in ACC |
| Description | The contents of the specified Data Memory are first incremented by 1. If the result is 0, the following instruction is skipped. The result is stored in the Accumulator but the specified Data Memory contents remain unchanged. As this requires the insertion of a dummy instruction while the next instruction is fetched, it is a two cycle instruction. If the result is not 0 the program proceeds with the following instruction. |
| Operation | $ACC \leftarrow [m] + 1$ Skip if $ACC = 0$ |
| Affected flag(s) | None |
| SNZ [m].i | Skip if bit i of Data Memory is not 0 |
| Description | If bit i of the specified Data Memory is not 0, the following instruction is skipped. As this requires the insertion of a dummy instruction while the next instruction is fetched, it is a two cycle instruction. If the result is 0 the program proceeds with the following instruction. |
| Operation | Skip if $[m].i \neq 0$ |
| Affected flag(s) | None |
| SUB A,[m] | Subtract Data Memory from ACC |
| Description | The specified Data Memory is subtracted from the contents of the Accumulator. The result is stored in the Accumulator. Note that if the result of subtraction is negative, the C flag will be cleared to 0, otherwise if the result is positive or zero, the C flag will be set to 1. |
| Operation | $ACC \leftarrow ACC - [m]$ |
| Affected flag(s) | OV, Z, AC, C |
| SUBM A,[m] | Subtract Data Memory from ACC with result in Data Memory |
| Description | The specified Data Memory is subtracted from the contents of the Accumulator. The result is stored in the Data Memory. Note that if the result of subtraction is negative, the C flag will be cleared to 0, otherwise if the result is positive or zero, the C flag will be set to 1. |
| Operation | $[m] \leftarrow ACC - [m]$ |
| Affected flag(s) | OV, Z, AC, C |
| SUB A,x | Subtract immediate data from ACC |
| Description | The immediate data specified by the code is subtracted from the contents of the Accumulator. The result is stored in the Accumulator. Note that if the result of subtraction is negative, the C flag will be cleared to 0, otherwise if the result is positive or zero, the C flag will be set to 1. |
| Operation | $ACC \leftarrow ACC - x$ |
| Affected flag(s) | OV, Z, AC, C |

| | |
|-------------------|--|
| SWAP [m] | Swap nibbles of Data Memory |
| Description | The low-order and high-order nibbles of the specified Data Memory are interchanged. |
| Operation | [m].3~[m].0 ↔ [m].7 ~ [m].4 |
| Affected flag(s) | None |
| SWAPA [m] | Swap nibbles of Data Memory with result in ACC |
| Description | The low-order and high-order nibbles of the specified Data Memory are interchanged. The result is stored in the Accumulator. The contents of the Data Memory remain unchanged. |
| Operation | ACC.3 ~ ACC.0 ← [m].7 ~ [m].4 ACC.7 ~ ACC.4 ← [m].3 ~ [m].0 |
| Affected flag(s) | None |
| SZ [m] | Skip if Data Memory is 0 |
| Description | If the contents of the specified Data Memory is 0, the following instruction is skipped. As this requires the insertion of a dummy instruction while the next instruction is fetched, it is a two cycle instruction. If the result is not 0 the program proceeds with the following instruction. |
| Operation | Skip if [m] = 0 |
| Affected flag(s) | None |
| SZA [m] | Skip if Data Memory is 0 with data movement to ACC |
| Description | The contents of the specified Data Memory are copied to the Accumulator. If the value is zero, the following instruction is skipped. As this requires the insertion of a dummy instruction while the next instruction is fetched, it is a two cycle instruction. If the result is not 0 the program proceeds with the following instruction. |
| Operation | ACC ← [m] Skip if [m] = 0 |
| Affected flag(s) | None |
| SZ [m].i | Skip if bit i of Data Memory is 0 |
| Description | If bit i of the specified Data Memory is 0, the following instruction is skipped. As this requires the insertion of a dummy instruction while the next instruction is fetched, it is a two cycle instruction. If the result is not 0, the program proceeds with the following instruction. |
| Operation | Skip if [m].i = 0 |
| Affected flag(s) | None |
| TABRDC [m] | Read table (current page) to TBLH and Data Memory |
| Description | The low byte of the program code (current page) addressed by the table pointer (TBLP) is moved to the specified Data Memory and the high byte moved to TBLH. |
| Operation | [m] ← program code (low byte) TBLH ← program code (high byte) |
| Affected flag(s) | None |
| TABRDL [m] | Read table (last page) to TBLH and Data Memory |
| Description | The low byte of the program code (last page) addressed by the table pointer (TBLP) is moved to the specified Data Memory and the high byte moved to TBLH. |
| Operation | [m] ← program code (low byte) TBLH ← program code (high byte) |
| Affected flag(s) | None |

| | |
|-------------------|--|
| XOR A,[m] | Logical XOR Data Memory to ACC |
| Description | Data in the Accumulator and the specified Data Memory perform a bitwise logical XOR operation. The result is stored in the Accumulator. |
| Operation | ACC ← ACC "XOR" [m] |
| Affected flag(s) | Z |
| XORM A,[m] | Logical XOR ACC to Data Memory |
| Description | Data in the specified Data Memory and the Accumulator perform a bitwise logical XOR operation. The result is stored in the Data Memory. |
| Operation | [m] ← ACC "XOR" [m] |
| Affected flag(s) | Z |
| XOR A,x | Logical XOR immediate data to ACC |
| Description | Data in the Accumulator and the specified immediate data perform a bitwise logical XOR operation. The result is stored in the Accumulator. |
| Operation | ACC ← ACC "XOR" x |
| Affected flag(s) | Z |

Package Information

20-pin SOP (300mil) Outline Dimensions

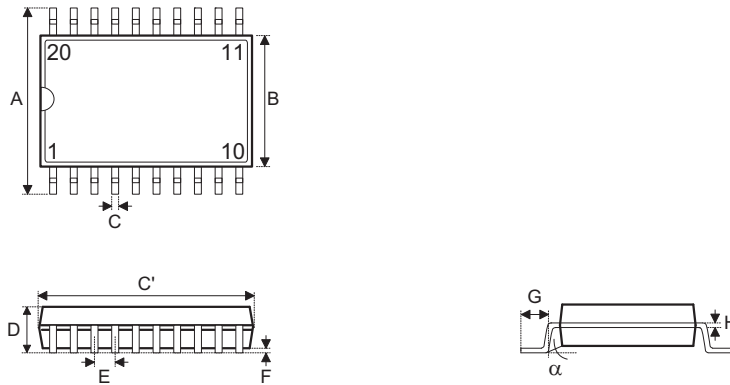

• MS-013

| Symbol | Dimensions in inch | | |
|----------|--------------------|-------|-------|
| | Min. | Nom. | Max. |
| A | 0.393 | — | 0.419 |
| B | 0.256 | — | 0.300 |
| C | 0.012 | — | 0.020 |
| C' | 0.496 | — | 0.512 |
| D | — | — | 0.104 |
| E | — | 0.050 | — |
| F | 0.004 | — | 0.012 |
| G | 0.016 | — | 0.050 |
| H | 0.008 | — | 0.013 |
| α | 0° | — | 8° |

| Symbol | Dimensions in mm | | |
|----------|------------------|------|-------|
| | Min. | Nom. | Max. |
| A | 9.98 | — | 10.64 |
| B | 6.50 | — | 7.62 |
| C | 0.30 | — | 0.51 |
| C' | 12.60 | — | 13.00 |
| D | — | — | 2.64 |
| E | — | 1.27 | — |
| F | 0.10 | — | 0.30 |
| G | 0.41 | — | 1.27 |
| H | 0.20 | — | 0.33 |
| α | 0° | — | 8° |

20-pin SSOP (150mil) Outline Dimensions

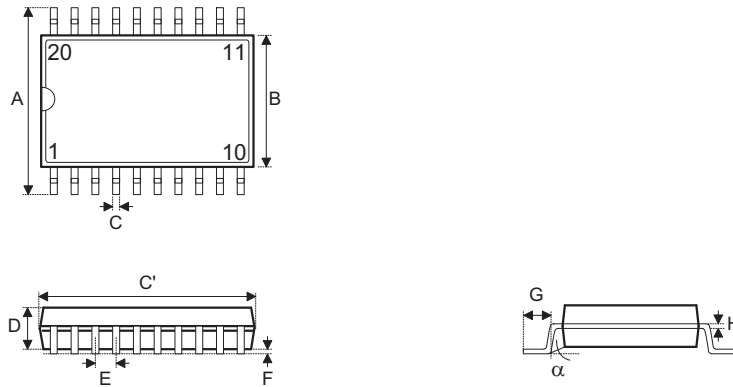

| Symbol | Dimensions in inch | | |
|----------|--------------------|-------|-------|
| | Min. | Nom. | Max. |
| A | 0.228 | — | 0.244 |
| B | 0.150 | — | 0.158 |
| C | 0.008 | — | 0.012 |
| C' | 0.335 | — | 0.347 |
| D | 0.049 | — | 0.065 |
| E | — | 0.025 | — |
| F | 0.004 | — | 0.010 |
| G | 0.015 | — | 0.050 |
| H | 0.007 | — | 0.010 |
| α | 0° | — | 8° |

| Symbol | Dimensions in mm | | |
|----------|------------------|------|------|
| | Min. | Nom. | Max. |
| A | 5.79 | — | 6.20 |
| B | 3.81 | — | 4.01 |
| C | 0.20 | — | 0.30 |
| C' | 8.51 | — | 8.81 |
| D | 1.24 | — | 1.65 |
| E | — | 0.64 | — |
| F | 0.10 | — | 0.25 |
| G | 0.38 | — | 1.27 |
| H | 0.18 | — | 0.25 |
| α | 0° | — | 8° |

28-pin SOP (300mil) Outline Dimensions

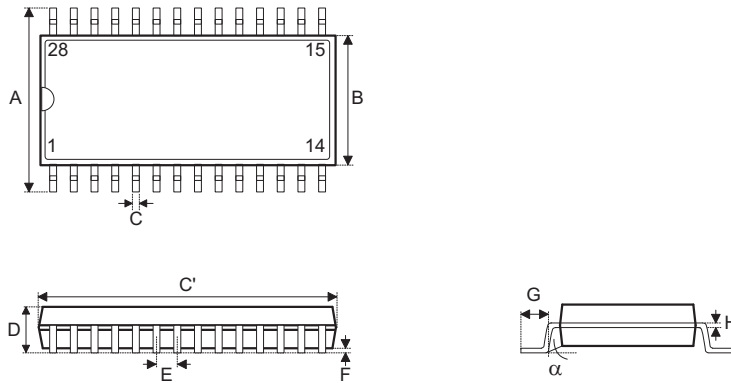

• MS-013

| Symbol | Dimensions in inch | | |
|----------|--------------------|-------|-------|
| | Min. | Nom. | Max. |
| A | 0.393 | — | 0.419 |
| B | 0.256 | — | 0.300 |
| C | 0.012 | — | 0.020 |
| C' | 0.697 | — | 0.713 |
| D | — | — | 0.104 |
| E | — | 0.050 | — |
| F | 0.004 | — | 0.012 |
| G | 0.016 | — | 0.050 |
| H | 0.008 | — | 0.013 |
| α | 0° | — | 8° |

| Symbol | Dimensions in mm | | |
|----------|------------------|------|-------|
| | Min. | Nom. | Max. |
| A | 9.98 | — | 10.64 |
| B | 6.50 | — | 7.62 |
| C | 0.30 | — | 0.51 |
| C' | 17.70 | — | 18.11 |
| D | — | — | 2.64 |
| E | — | 1.27 | — |
| F | 0.10 | — | 0.30 |
| G | 0.41 | — | 1.27 |
| H | 0.20 | — | 0.33 |
| α | 0° | — | 8° |

28-pin SSOP (150mil) Outline Dimensions

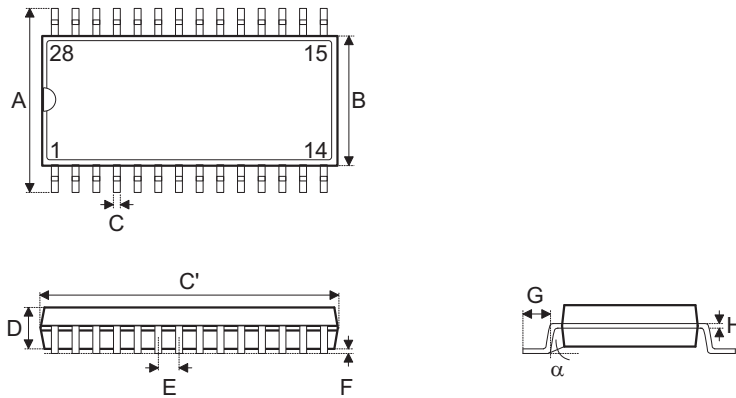

| Symbol | Dimensions in inch | | |
|----------|--------------------|-------|-------|
| | Min. | Nom. | Max. |
| A | 0.228 | — | 0.244 |
| B | 0.150 | — | 0.157 |
| C | 0.008 | — | 0.012 |
| C' | 0.386 | — | 0.394 |
| D | 0.054 | — | 0.060 |
| E | — | 0.025 | — |
| F | 0.004 | — | 0.010 |
| G | 0.022 | — | 0.028 |
| H | 0.007 | — | 0.010 |
| α | 0° | — | 8° |

| Symbol | Dimensions in mm | | |
|----------|------------------|------|-------|
| | Min. | Nom. | Max. |
| A | 5.79 | — | 6.20 |
| B | 3.81 | — | 3.99 |
| C | 0.20 | — | 0.30 |
| C' | 9.80 | — | 10.01 |
| D | 1.37 | — | 1.52 |
| E | — | 0.64 | — |
| F | 0.10 | — | 0.25 |
| G | 0.56 | — | 0.71 |
| H | 0.18 | — | 0.25 |
| α | 0° | — | 8° |

SAW Type 32-pin (5mm×5mm) QFN Outline Dimensions

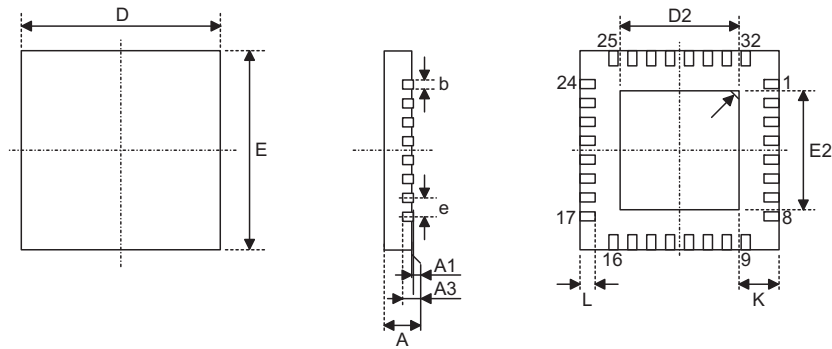

| Symbol | Dimensions in inch | | |
|--------|--------------------|-------|-------|
| | Min. | Nom. | Max. |
| A | 0.028 | — | 0.031 |
| A1 | 0.000 | — | 0.002 |
| A3 | — | 0.008 | — |
| b | 0.007 | — | 0.012 |
| D | — | 0.197 | — |
| E | — | 0.197 | — |
| e | — | 0.020 | — |
| D2 | 0.049 | — | 0.128 |
| E2 | 0.049 | — | 0.128 |
| L | 0.012 | — | 0.020 |
| K | — | — | — |

| Symbol | Dimensions in mm | | |
|--------|------------------|------|------|
| | Min. | Nom. | Max. |
| A | 0.70 | — | 0.80 |
| A1 | 0.00 | — | 0.05 |
| A3 | — | 0.20 | — |
| b | 0.18 | — | 0.30 |
| D | — | 5.00 | — |
| E | — | 5.00 | — |
| e | — | 0.50 | — |
| D2 | 1.25 | — | 3.25 |
| E2 | 1.25 | — | 3.25 |
| L | 0.30 | — | 0.50 |
| K | — | — | — |

SAW Type 40-pin (6mm×6mm for 0.85mm) QFN Outline Dimensions

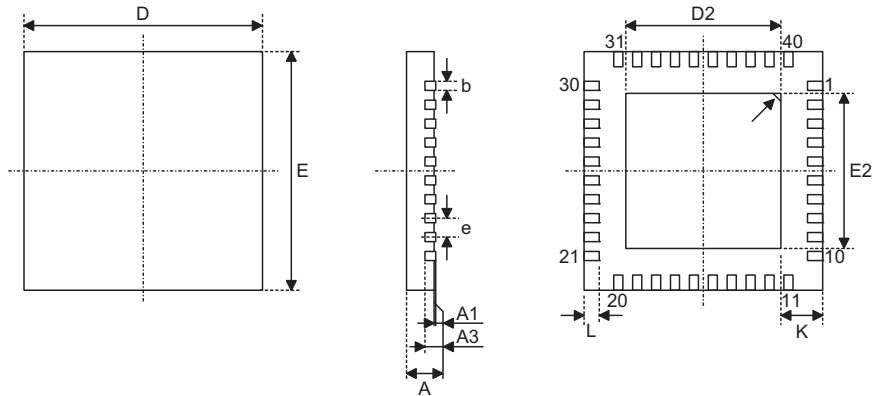

• GTK

| Symbol | Dimensions in inch | | |
|--------|--------------------|-------|-------|
| | Min. | Nom. | Max. |
| A | 0.031 | 0.033 | 0.035 |
| A1 | 0.000 | 0.001 | 0.002 |
| A3 | — | 0.008 | — |
| b | 0.007 | 0.010 | 0.012 |
| D | — | 0.236 | — |
| E | — | 0.236 | — |
| e | — | 0.020 | — |
| D2 | 0.173 | 0.177 | 0.179 |
| E2 | 0.173 | 0.177 | 0.179 |
| L | 0.014 | 0.016 | 0.018 |
| K | 0.008 | — | — |

| Symbol | Dimensions in mm | | |
|--------|------------------|------|------|
| | Min. | Nom. | Max. |
| A | 0.80 | 0.85 | 0.90 |
| A1 | 0.00 | 0.02 | 0.05 |
| A3 | — | 0.20 | — |
| b | 0.18 | 0.25 | 0.30 |
| D | — | 6.00 | — |
| E | — | 6.00 | — |
| e | — | 0.50 | — |
| D2 | 4.40 | 4.50 | 4.55 |
| E2 | 4.40 | 4.50 | 4.55 |
| L | 0.35 | 0.40 | 0.45 |
| K | 0.20 | — | — |

48-pin SSOP (300mil) Outline Dimensions

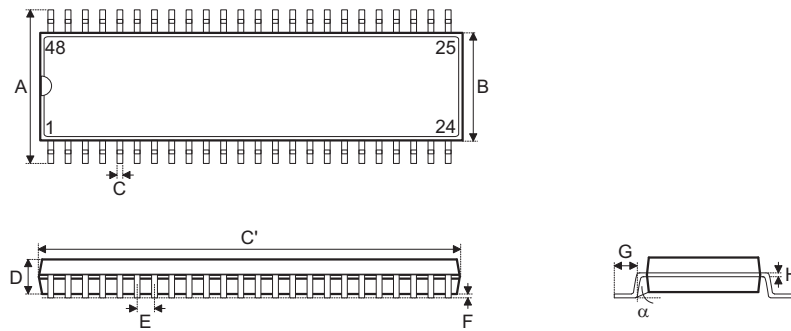

| Symbol | Dimensions in inch | | |
|----------|--------------------|-------|-------|
| | Min. | Nom. | Max. |
| A | 0.395 | — | 0.420 |
| B | 0.291 | — | 0.299 |
| C | 0.008 | — | 0.012 |
| C' | 0.613 | — | 0.637 |
| D | 0.085 | — | 0.099 |
| E | — | 0.025 | — |
| F | 0.004 | — | 0.010 |
| G | 0.025 | — | 0.035 |
| H | 0.004 | — | 0.012 |
| α | 0° | — | 8° |

| Symbol | Dimensions in mm | | |
|----------|------------------|------|-------|
| | Min. | Nom. | Max. |
| A | 10.03 | — | 10.67 |
| B | 7.39 | — | 7.59 |
| C | 0.20 | — | 0.30 |
| C' | 15.57 | — | 16.18 |
| D | 2.16 | — | 2.51 |
| E | — | 0.64 | — |
| F | 0.10 | — | 0.25 |
| G | 0.64 | — | 0.89 |
| H | 0.10 | — | 0.30 |
| α | 0° | — | 8° |

64-pin LQFP (7mm×7mm) Outline Dimensions

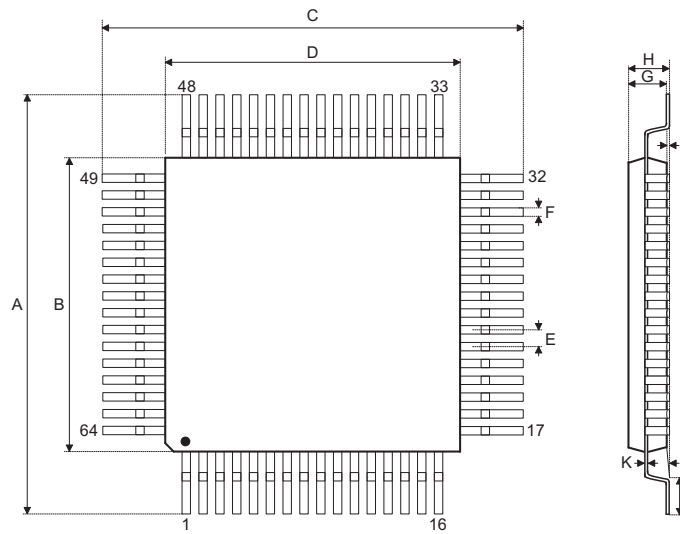

| Symbol | Dimensions in mm | | |
|----------|------------------|------|------|
| | Min. | Nom. | Max. |
| A | 8.90 | — | 9.10 |
| B | 6.90 | — | 7.10 |
| C | 8.90 | — | 9.10 |
| D | 6.90 | — | 7.10 |
| E | — | 0.40 | — |
| F | 0.13 | — | 0.23 |
| G | 1.35 | — | 1.45 |
| H | — | — | 1.60 |
| I | 0.05 | — | 0.15 |
| J | 0.45 | — | 0.75 |
| K | 0.09 | — | 0.20 |
| α | 0° | — | 7° |

| Symbol | Dimensions in inch | | |
|----------|--------------------|-------|-------|
| | Min. | Nom. | Max. |
| A | 0.350 | — | 0.358 |
| B | 0.272 | — | 0.280 |
| C | 0.350 | — | 0.358 |
| D | 0.272 | — | 0.280 |
| E | — | 0.016 | — |
| F | 0.005 | — | 0.009 |
| G | 0.053 | — | 0.057 |
| H | — | — | 0.063 |
| I | 0.002 | — | 0.006 |
| J | 0.018 | — | 0.030 |
| K | 0.004 | — | 0.008 |
| α | 0° | — | 7° |

Product Tape and Reel Specifications

Reel Dimensions

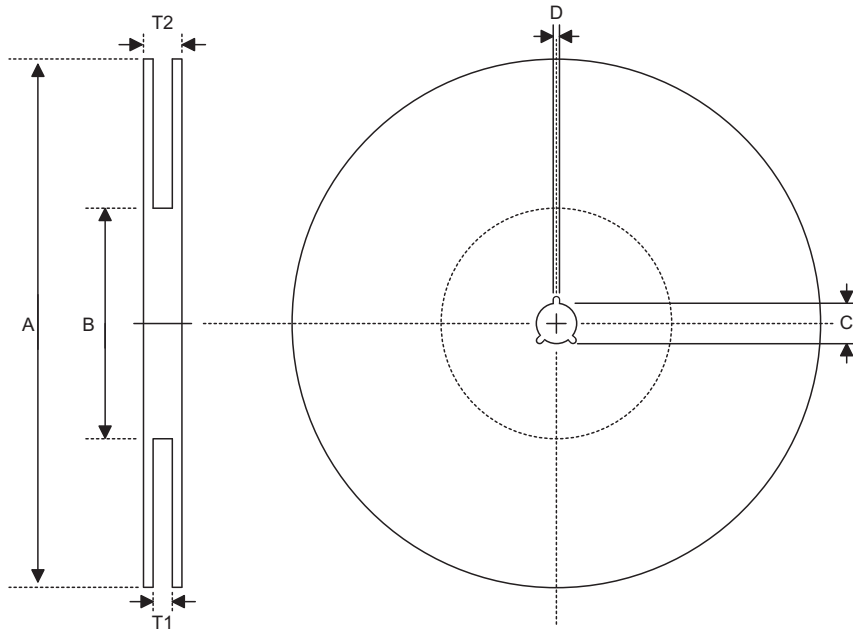

SOP 20W

| Symbol | Description | Dimensions in mm |
|--------|-----------------------|---------------------------|
| A | Reel Outer Diameter | 330.0±1.0 |
| B | Reel Inner Diameter | 100.0±1.5 |
| C | Spindle Hole Diameter | 13.0 ^{+0.5/-0.2} |
| D | Key Slit Width | 2.0±0.5 |
| T1 | Space Between Flange | 24.8 ^{+0.3/-0.2} |
| T2 | Reel Thickness | 30.2±0.2 |

SSOP 20S (150mil)

| Symbol | Description | Dimensions in mm |
|--------|-----------------------|---------------------------|
| A | Reel Outer Diameter | 330.0±1.0 |
| B | Reel Inner Diameter | 100.0±1.5 |
| C | Spindle Hole Diameter | 13.0 ^{+0.5/-0.2} |
| D | Key Slit Width | 2.0±0.5 |
| T1 | Space Between Flange | 16.8 ^{+0.3/-0.2} |
| T2 | Reel Thickness | 22.2±0.2 |

SOP 28W (300mil)

| Symbol | Description | Dimensions in mm |
|--------|-----------------------|---------------------------|
| A | Reel Outer Diameter | 330.0±1.0 |
| B | Reel Inner Diameter | 100.0±1.5 |
| C | Spindle Hole Diameter | 13.0 ^{+0.5/-0.2} |
| D | Key Slit Width | 2.0±0.5 |
| T1 | Space Between Flange | 24.8 ^{+0.3/-0.2} |
| T2 | Reel Thickness | 30.2±0.2 |

SSOP 28S (150mil)

| Symbol | Description | Dimensions in mm |
|--------|-----------------------|---------------------------|
| A | Reel Outer Diameter | 330.0±1.0 |
| B | Reel Inner Diameter | 100.0±1.5 |
| C | Spindle Hole Diameter | 13.0 ^{+0.5/-0.2} |
| D | Key Slit Width | 2.0±0.5 |
| T1 | Space Between Flange | 16.8 ^{+0.3/-0.2} |
| T2 | Reel Thickness | 22.2±0.2 |

SSOP 48W

| Symbol | Description | Dimensions in mm |
|--------|-----------------------|---------------------------|
| A | Reel Outer Diameter | 330.0±1.0 |
| B | Reel Inner Diameter | 100.0±0.1 |
| C | Spindle Hole Diameter | 13.0 ^{+0.5/-0.2} |
| D | Key Slit Width | 2.0±0.5 |
| T1 | Space Between Flange | 32.2 ^{+0.3/-0.2} |
| T2 | Reel Thickness | 38.2±0.2 |

Carrier Tape Dimensions

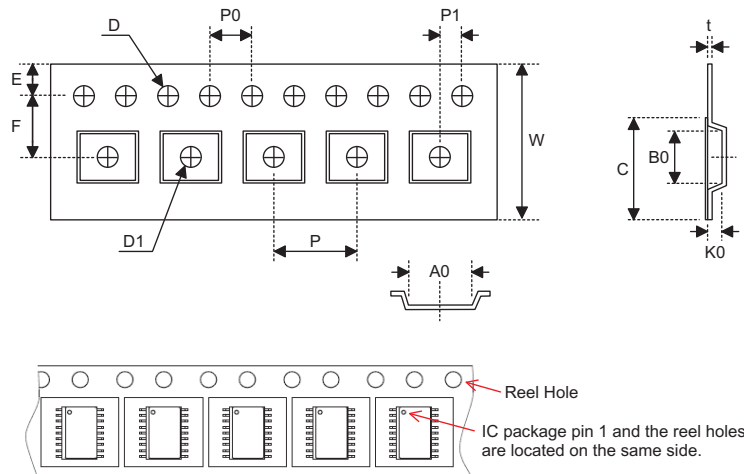

SOP 20W

| Symbol | Description | Dimensions in mm |
|--------|--|-----------------------------|
| W | Carrier Tape Width | 24.0 ^{+0.3/-0.1} |
| P | Cavity Pitch | 12.0±0.1 |
| E | Perforation Position | 1.75±0.10 |
| F | Cavity to Perforation (Width Direction) | 11.5±0.1 |
| D | Perforation Diameter | 1.5 ^{+0.1/-0.0} |
| D1 | Cavity Hole Diameter | 1.50 ^{+0.25/-0.00} |
| P0 | Perforation Pitch | 4.0±0.1 |
| P1 | Cavity to Perforation (Length Direction) | 2.0±0.1 |
| A0 | Cavity Length | 10.8±0.1 |
| B0 | Cavity Width | 13.3±0.1 |
| K0 | Cavity Depth | 3.2±0.1 |
| t | Carrier Tape Thickness | 0.30±0.05 |
| C | Cover Tape Width | 21.3±0.1 |

SSOP 20S (150mil)

| Symbol | Description | Dimensions in mm |
|--------|--|-----------------------------|
| W | Carrier Tape Width | 16.0 ^{+0.3/-0.1} |
| P | Cavity Pitch | 8.0±0.1 |
| E | Perforation Position | 1.75±0.10 |
| F | Cavity to Perforation (Width Direction) | 7.5±0.1 |
| D | Perforation Diameter | 1.5 ^{+0.1/-0.0} |
| D1 | Cavity Hole Diameter | 1.50 ^{+0.25/-0.00} |
| P0 | Perforation Pitch | 4.0±0.1 |
| P1 | Cavity to Perforation (Length Direction) | 2.0±0.1 |
| A0 | Cavity Length | 6.5±0.1 |
| B0 | Cavity Width | 9.0±0.1 |
| K0 | Cavity Depth | 2.3±0.1 |
| t | Carrier Tape Thickness | 0.30±0.05 |
| C | Cover Tape Width | 13.3±0.1 |

SOP 28W (300mil)

| Symbol | Description | Dimensions in mm |
|--------|--|-----------------------------|
| W | Carrier Tape Width | 24.0±0.3 |
| P | Cavity Pitch | 12.0±0.1 |
| E | Perforation Position | 1.75±0.10 |
| F | Cavity to Perforation (Width Direction) | 11.5±0.1 |
| D | Perforation Diameter | 1.5 ^{+0.1/-0.0} |
| D1 | Cavity Hole Diameter | 1.50 ^{+0.25/-0.00} |
| P0 | Perforation Pitch | 4.0±0.1 |
| P1 | Cavity to Perforation (Length Direction) | 2.0±0.1 |
| A0 | Cavity Length | 10.85±0.10 |
| B0 | Cavity Width | 18.34±0.10 |
| K0 | Cavity Depth | 2.97±0.10 |
| t | Carrier Tape Thickness | 0.35±0.01 |
| C | Cover Tape Width | 21.3±0.1 |

SSOP 28S (150mil)

| Symbol | Description | Dimensions in mm |
|--------|--|-----------------------------|
| W | Carrier Tape Width | 16.0±0.3 |
| P | Cavity Pitch | 8.0±0.1 |
| E | Perforation Position | 1.75±0.1 |
| F | Cavity to Perforation (Width Direction) | 7.5±0.1 |
| D | Perforation Diameter | 1.55 ^{+0.10/-0.00} |
| D1 | Cavity Hole Diameter | 1.50 ^{+0.25/-0.00} |
| P0 | Perforation Pitch | 4.0±0.1 |
| P1 | Cavity to Perforation (Length Direction) | 2.0±0.1 |
| A0 | Cavity Length | 6.5±0.1 |
| B0 | Cavity Width | 10.3±0.1 |
| K0 | Cavity Depth | 2.1±0.1 |
| t | Carrier Tape Thickness | 0.30±0.05 |
| C | Cover Tape Width | 13.3±0.1 |

Carrier Tape Dimensions

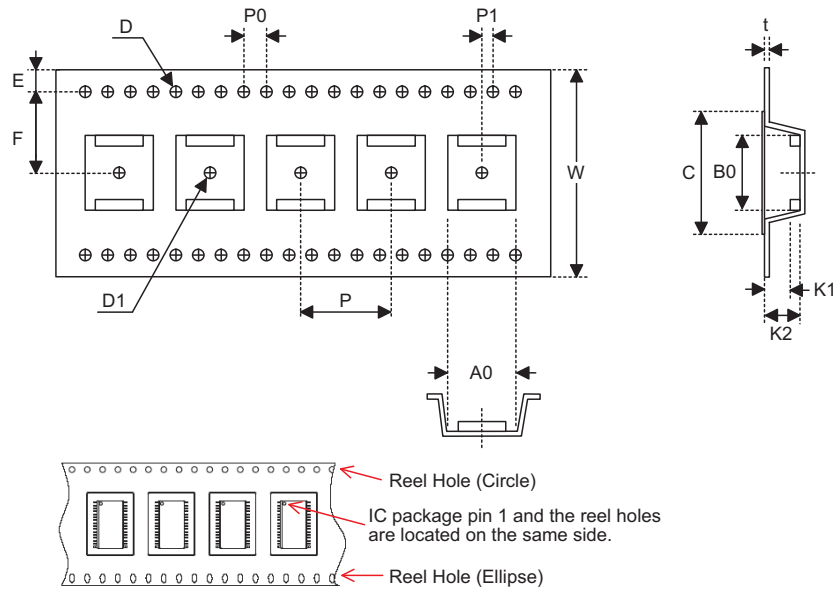

SSOP 48W

| Symbol | Description | Dimensions in mm |
|--------|--|-----------------------------|
| W | Carrier Tape Width | 32.0±0.3 |
| P | Cavity Pitch | 16.0±0.1 |
| E | Perforation Position | 1.75±0.10 |
| F | Cavity to Perforation (Width Direction) | 14.2±0.1 |
| D | Perforation Diameter | 2 Min. |
| D1 | Cavity Hole Diameter | 1.50 ^{+0.25/-0.00} |
| P0 | Perforation Pitch | 4.0±0.1 |
| P1 | Cavity to Perforation (Length Direction) | 2.0±0.1 |
| A0 | Cavity Length | 12.0±0.1 |
| B0 | Cavity Width | 16.2±0.1 |
| K1 | Cavity Depth | 2.4±0.1 |
| K2 | Cavity Depth | 3.2±0.1 |
| t | Carrier Tape Thickness | 0.35±0.05 |
| C | Cover Tape Width | 25.5±0.1 |

Holtek Semiconductor Inc. (Headquarters)

No.3, Creation Rd. II, Science Park, Hsinchu, Taiwan
Tel: 886-3-563-1999
Fax: 886-3-563-1189
<http://www.holtek.com.tw>

Holtek Semiconductor Inc. (Taipei Sales Office)

4F-2, No. 3-2, YuanQu St., Nankang Software Park, Taipei 115, Taiwan
Tel: 886-2-2655-7070
Fax: 886-2-2655-7373
Fax: 886-2-2655-7383 (International sales hotline)

Holtek Semiconductor Inc. (Shenzhen Sales Office)

5F, Unit A, Productivity Building, No.5 Gaoxin M 2nd Road, Nanshan District, Shenzhen, China 518057
Tel: 86-755-8616-9908, 86-755-8616-9308
Fax: 86-755-8616-9722

Holtek Semiconductor (USA), Inc. (North America Sales Office)

46729 Fremont Blvd., Fremont, CA 94538
Tel: 1-510-252-9880
Fax: 1-510-252-9885
<http://www.holtek.com>

Copyright © 2010 by HOLTEK SEMICONDUCTOR INC.

The information appearing in this Data Sheet is believed to be accurate at the time of publication. However, Holtek assumes no responsibility arising from the use of the specifications described. The applications mentioned herein are used solely for the purpose of illustration and Holtek makes no warranty or representation that such applications will be suitable without further modification, nor recommends the use of its products for application that may present a risk to human life due to malfunction or otherwise. Holtek's products are not authorized for use as critical components in life support devices or systems. Holtek reserves the right to alter its products without prior notification. For the most up-to-date information, please visit our web site at <http://www.holtek.com.tw>.