



Product Summary

EP560 SD/SDIO/MMC Slave Controller

FEATURES

- Compatible with SD/SDIO specification 2.0 with 1 and 4 bit data transfer
- Option to support MMC 8-bit data width.
- Support SD, SPI and optional MMC bus protocol.
- Support for both standard capacity and high capacity (SDHC) memory cards.
- Supports high speed mode up to maximum transfer rate of 25Mbyte/sec for SD and 50Mbyte/sec for MMC.
- Simple 32-bit bus master interface to DMA data into user memory space.
- Selectable maximum block size from 512 to 16Kbytes.
- Each IO function includes up to 4096 bytes of data buffer.
- Process most commands automatically without user interference.
- Contains SD memory/SDIO standard slave register set.
- Supports multi-function SD cards, suspend and resume, read wait, block transfers, and SDIO interrupts.
- Password Protection for SD cards.
- Options for AHB, APB, Wishbone, SH4 and Generic user interface.
- Options for interrupt-based user interface.

BLOCK DIAGRAM

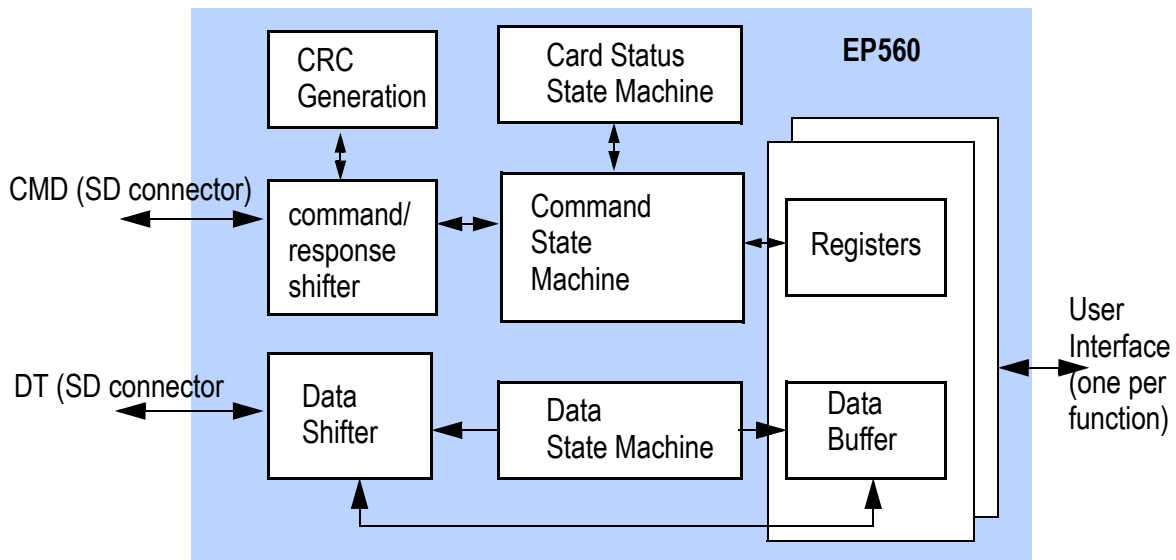



DESCRIPTIONS

The SD Slave Controller is designed to reside within an SD memory, SDIO, or SD Combo Card. It serves as an interface between the SD bus and user logic that provides the actual function of the card. It is designed to integrate with user logic to make various devices using the SD bus protocol, such as storage or wireless network card.

The SD slave controller supports both 1 and 4 bit SD interface (up to 8 bits in optional MMC support) and SPI mode. Data rate of up to 25Mbyte/sec (200Mbps) can be realized with SD interface. Features such as plug and play, auto-detection, error correction, write protection are standard with SD card interface and are supported.

As a slave device, the SD slave controller receives commands from the host through the SD interface. Most of the commands are processed locally by the controller without any help from the user logic. The majority of the standard SD register set is also implemented within the slave controller and process by the core without help from the user logic.

In case of memory or IO access that needs to be forwarded to the user logic, the slave controller handles all the SD bus protocol and presents the request to the user logic as simple read and write request through parallel address and data buses. Burst transfer of up to 2048 bytes per transfer and user defined wait states are supported on the user interface to maximize data bandwidth. The slave controller also contains data buffer to match the speed differences between the user interface and the SD interface. It allows a much more efficient use of the user interface.

SD Combo card and multi-function cards are supported by the EP560. With Combo card and multi-function, one user interface is dedicated for each function so all functions can operate in parallel.

The user interface of the EP560 core can operate either in DMA mode or interrupt mode. In the normal DMA mode, the EP560 is a bus master that transfers data between the user's memory and the SD host. It functions like a DMA controller under the control of the SD host. In the optional interrupt mode, the communication between the EP560 and the user logic is interrupt driven. The EP560 asserts interrupt to the local CPU whenever it needs to access user memory. The main body of this data sheets describe the EP560 in DMA mode and the interrupt mode is described in the Appendix.

With the EP560, SD card design can be realized with very little development cost. The designer can add SD memory and SDIO interface capability to the design by simply adding the EP560 module without changing the rest of the system architecture.



EP560 SD/SDIO/MMC Slave Controller

APPLICATION DIAGRAM

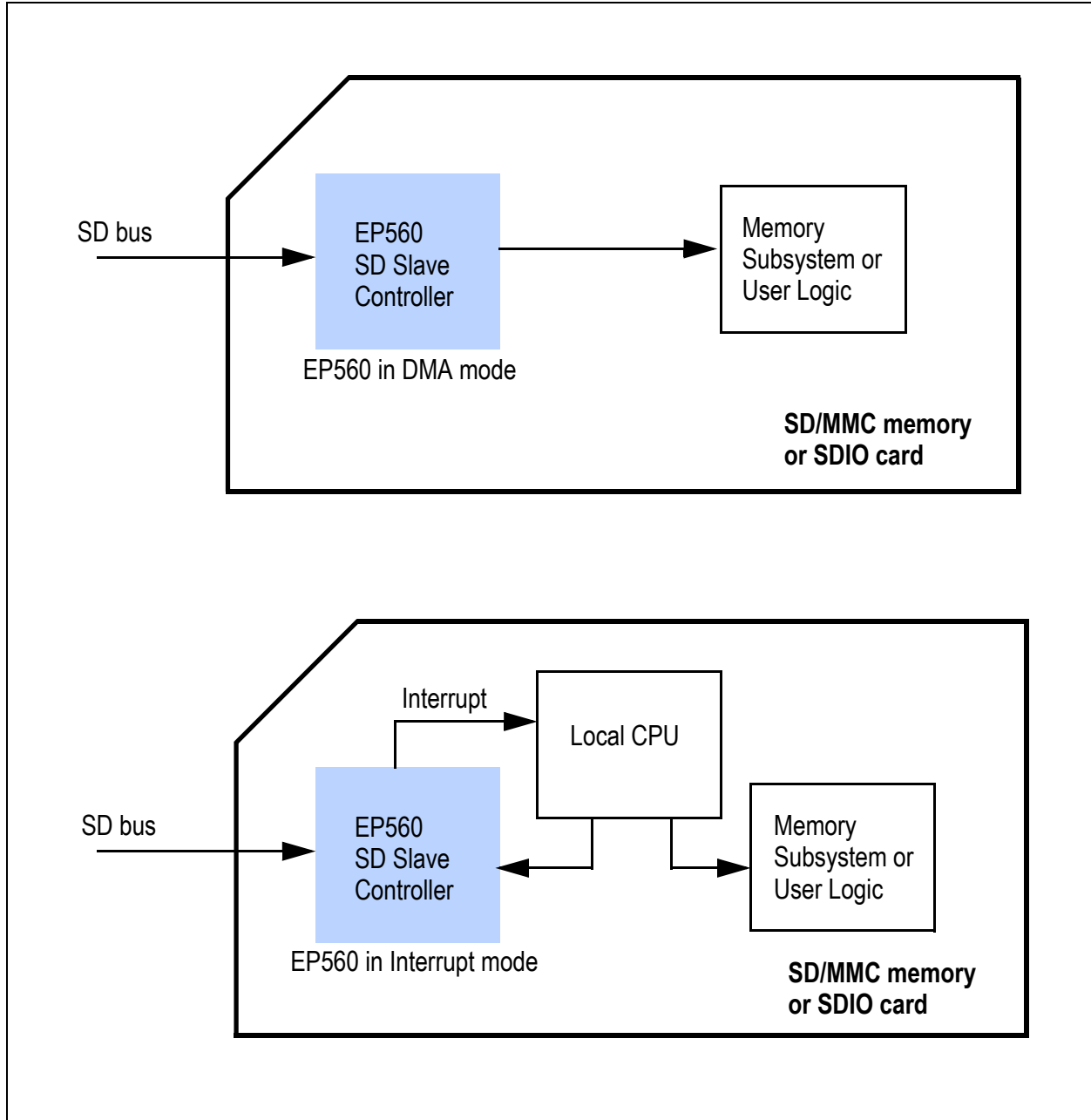



EP560 SD/SDIO/MMC Slave Controller

OPTIONAL FEATURES

The EP560 standard core features a simple generic user interface which can be connected easily into any design. Eureka also offer the EP560 with AHB, APB, Wishbone and SH4 bus interface. The EP560 can also come with interrupt mode interface to allow use logic to access EP560 as a slave device or in DMA mode which allows the EP560 to access user logic.

ACTEL DEVICE UTILIZATION DATA

Family	Device (-speed grade)	Utilization			Performance	
		SEQ	COMB	Total	RAM	
ProASIC3	A3P600-2	1099	5852	50%	2	49Mhz
Axcelerator	AX500-2	1098	3178	53%	2	56Mhz
IGLOO	AGL600V5	1009	5309	46%	2	31Mhz
Fusion	AFS1500	1009	5240	16%	2	45Mhz