

Product Specification

# SPECIFICATION FOR APPROVAL

- ( ) Preliminary Specification
- (●) Final Specification

Title	42.0" WUXGA TFT LCD
-------	---------------------

BUYER	General
MODEL	

SUPPLIER	LG.Philips LCD Co., Ltd.
*MODEL	LC420WUF
SUFFIX	SAA1(RoHS Verified)

\*When you obtain standard approval, please use the above model name without suffix

APPROVED BY	SIGNATURE DATE
/	_____
/	_____
/	_____

APPROVED BY	SIGNATURE DATE
<b>H.S. Baek / Senior Manager</b>	_____
<b>REVIEWED BY</b>	
<b>S.Y. Paik / Manager</b>	_____
<b>PREPARED BY</b>	
<b>J.B. Chun / Engineer</b>	_____

Please return 1 copy for your confirmation with your signature and comments.

**TV Product Development Dept.  
LG. Philips LCD Co., Ltd**

## Product Specification

**CONTENTS**

Number	ITEM	Page
	COVER	1
	CONTENTS	2
	RECORD OF REVISIONS	3
1	GENERAL DESCRIPTION	4
2	ABSOLUTE MAXIMUM RATINGS	5
3	ELECTRICAL SPECIFICATIONS	6
3-1	ELECTRICAL CHARACTERISTICS	6
3-2	INTERFACE CONNECTIONS	10
3-3	SIGNAL TIMING SPECIFICATIONS	13
3-4	SIGNAL TIMING WAVEFORMS	14
3-5	COLOR DATA REFERENCE	15
3-6	POWER SEQUENCE	16
4	OPTICAL SPECIFICATIONS	17
5	MECHANICAL CHARACTERISTICS	21
6	RELIABILITY	24
7	INTERNATIONAL STANDARDS	25
7-1	SAFETY	25
7-2	EMC	25
8	PACKING	26
8-1	DESIGNATION OF LOT MARK	26
8-2	PACKING FORM	26
9	PRECAUTIONS	27
9-1	MOUNTING PRECAUTIONS	27
9-2	OPERATING PRECAUTIONS	27
9-3	ELECTROSTATIC DISCHARGE CONTROL	28
9-4	PRECAUTIONS FOR STRONG LIGHT EXPOSURE	28
9-5	STORAGE	28
9-6	HANDLING PRECAUTIONS FOR PROTECTION FILM	28



## Product Specification

## 1. General Description

LC420WUF is a Color Active Matrix Liquid Crystal Display with an integral External Electrode Fluorescent Lamp(EEFL) backlight system. The matrix employs a-Si Thin Film Transistor as the active element. It is a transmissive type display operating in the normally black mode. It has a 42 inch diagonally measured active display area with WUXGA resolution (1080 vertical by 1920 horizontal pixel array) Each pixel is divided into Red, Green and Blue sub-pixels or dots which are arranged in vertical stripes. Gray scale or the luminance of the sub-pixel color is determined with a 10-bit gray scale signal for each dot, thus presenting a palette of more than 1.06Billion of colors. It has been designed to apply the 10-bit 4 port LVDS interface. It is intended to support LCD TV, PCTV where high brightness, super wide viewing angle, high color gamut, high color depth and fast moving picture response time are important.

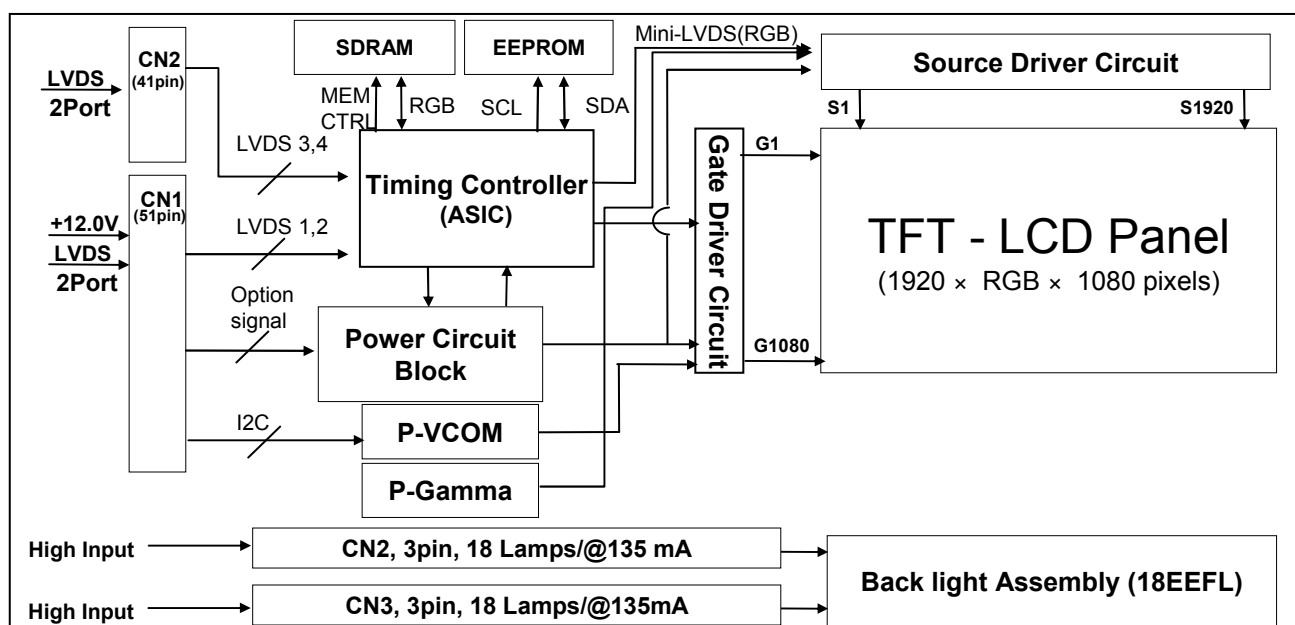

## General Features

Active Screen Size	42.02 inches(1067.31mm) diagonal
Outline Dimension	983.0(H) x 576.0 (V) x 47.3 mm(D) (Typ.)
Pixel Pitch	0.4845 mm x 0.4845 mm
Pixel Format	1920 horiz. by 1080 vert. Pixels, RGB stripe arrangement
Color Depth	10bit(D) , 1.06Billion colors
Luminance, White	500 cd/m <sup>2</sup> (Center 1point ,Typ.)
Viewing Angle (CR>10)	Viewing angle free ( R/L 178 (Typ.), U/D 178 (Typ.))
Power Consumption	Total 168.1 W (Typ.) (Logic = 7.3 W, Backlight=160.8W @ with Inverter)
Weight	11.0Kg (Typ.)
Display Mode	Transmissive mode, Normally black
Surface Treatment	Hard coating(3H), Anti-glare treatment of the front polarizer (Haze 13%)

## Product Specification

## 2. Absolute Maximum Ratings

The following items are maximum values which, if exceeded, may cause faulty operation or damage to the LCD module.

**Table 1. ABSOLUTE MAXIMUM RATINGS**

Parameter		Symbol	Value		Unit	Remark
			Min	Max		
Power Input Voltage	LCD circuit	V <sub>LCD</sub>	-0.3	+14.0	V [DC]	at 25 ± 2 °C
B/L Input voltage	Operating Voltage (one side)	V <sub>OP</sub>	700	1100	V [RMS]	at 25 ± 2 °C Burst Dimming Duty 100%
Operating Temperature		T <sub>OP</sub>	0	+50	°C	Note 1
Storage Temperature		T <sub>ST</sub>	-20	+60	°C	
Operating Ambient Humidity		H <sub>OP</sub>	10	90	%RH	
Storage Humidity		H <sub>ST</sub>	10	90	%RH	

- Notes : 1. Temperature and relative humidity range are shown in the figure below.  
Wet bulb temperature should be 39 °C Max, and no condensation.  
2. Gravity mura can be guaranteed under 40°C condition.

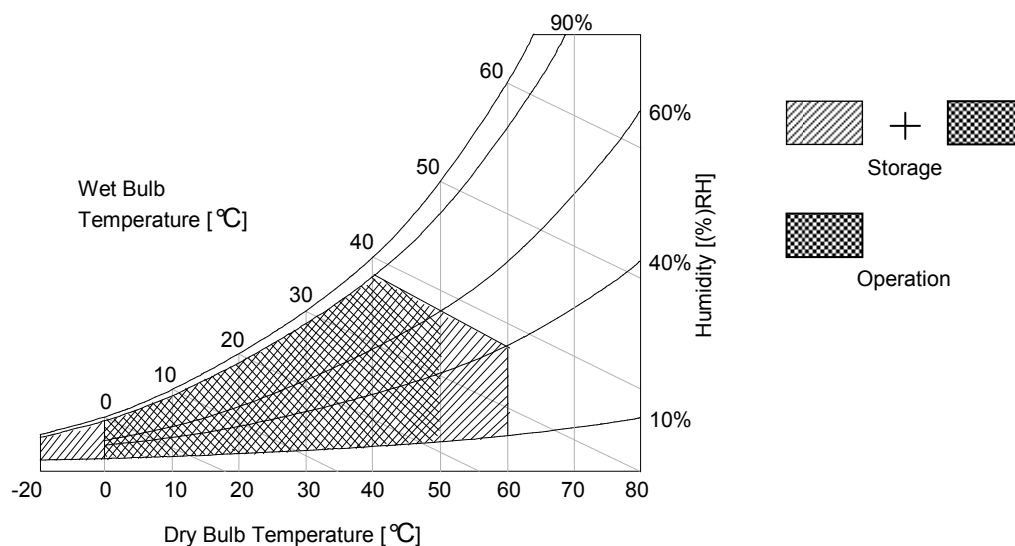

## Product Specification

### 3. Electrical Specifications

#### 3-1. Electrical Characteristics

It requires two power inputs. One is employed to power for the LCD circuit. The other is used for the EEFL backlight and inverter circuit.

**Table 2. ELECTRICAL CHARACTERISTICS**

Parameter	Symbol	Value			Unit	Note
		Min	Typ	Max		
Circuit :						
Power Input Voltage	V <sub>LCD</sub>	11.4	12.0	12.6	V <sub>DC</sub>	
Power Input Current	I <sub>LCD</sub>	423	605	787	mA	1
		560	800	1040	mA	2
Power Consumption	P <sub>LCD</sub>	-	7.3	9.4	Watt	1
Rush current	I <sub>RUSH</sub>	-	-	5	A	3

- Notes : 1. The specified current and power consumption are under the  $V_{LCD}=12.0V$ ,  $25 \pm 2^{\circ}C$ ,  $f_V=120Hz$  condition whereas mosaic pattern(8 x 6) is displayed and  $f_V$  is the frame frequency.  
 2. The current is specified at full white pattern.  
 3. The duration of rush current is about 2ms and rising time of power input is 0.5ms (min)

White : 1023Gray  
 Black : 0Gray

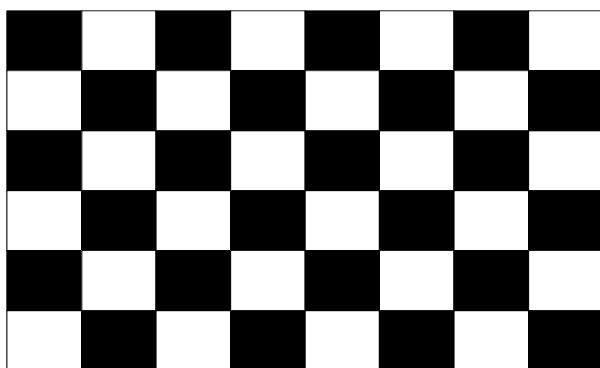

Mosaic Pattern(8 x 6)

White : 1023 Gray



Full White pattern

## Product Specification

Table 3. ELECTRICAL CHARACTERISTICS (Continue)

Parameter	Symbol	Values			Unit	Notes
		Min	Typ	Max		
<b>Backlight Assembly :</b>						
Operating Voltage (one side, fBL=45KHz, IBL= 135mA <sub>RMS</sub> )	VBL	800	950	1100	V <sub>RMS</sub>	1, 2
Operating Current (one side)	IBL	130	135	140	mA <sub>RMS</sub>	1
Established Starting Voltage (one side)	0℃	-	-	1200	V <sub>RMS</sub>	1, 3
	25℃	-	-	1000		
Operating Frequency	fBL	43	45	47	KHz	4
Striking Time	S TIME	-	-	1.5	sec	3
Power Consumption	PBL		160.8	172.0	Watt	6
Burst Dimming Duty	PWM duty	20		100	%	9
Burst Dimming Frequency	1/T	98		182	Hz	9

Parameter	Symbol	Values			Unit	Notes
		Min	Typ	Max		
<b>Lamp : (APPENDIX-V)</b>						
Lamp Voltage (one side)	VLAMP	945	1050	1155	V <sub>RMS</sub>	1, 2
Lamp Current (one side)	ILAMP	-	7.5	-	mA <sub>RMS</sub>	1
Discharge Stabilization Time	TS	-	-	3	Min	1, 5
Lamp Frequency	f LAMP	40	45	80	KHz	
Lamp Temperature	TLAMP			130	℃	
Established Starting Voltage	0℃	Vs		2370	V <sub>RMS</sub>	1, 3
	25℃	Vs		1980		
Life Time		50,000			Hrs	7

Note : The design of the inverter must have specifications for the lamp in LCD Assembly.

The electrical characteristics of inverter are based on High-High Driving type.

The performance of the lamps in LCM, for example life time or brightness, is extremely influenced by the characteristics of the DC-AC inverter. So, all the parameters of an inverter should be carefully designed so as not to produce too much leakage current from high-voltage output of the inverter.

When you design or order the inverter, please make sure unwanted lighting caused by the mismatch of the lamp and the inverter (no lighting, flicker, etc) has never been occurred. When you confirm it, the LCD- Assembly should be operated in the same condition as installed in your instrument.

※ Do not attach a conductive tape to lamp connecting wire.

If you attach conductive tape to the lamp wire, not only luminance level can be lower than typical one but also inverter operate abnormally on account of leakage current which is generated between lamp wire and conductive tape.

- Specified values are defined for a Backlight Assembly.( IBL : 18 lamp, 7.5mA/Lamp)
- Operating voltage is measured at  $25 \pm 2$ ℃(after 2hr.aging). The variance range for operating voltage is  $\pm 10\%$ .
- The established starting voltage [ Vs ] should be applied to the lamps for more than Striking time (S TIME) for start-up. Inverter open voltage must be more than established starting voltage. Otherwise, the lamps may not be turned on. The used lamp current is typical value.

## Product Specification

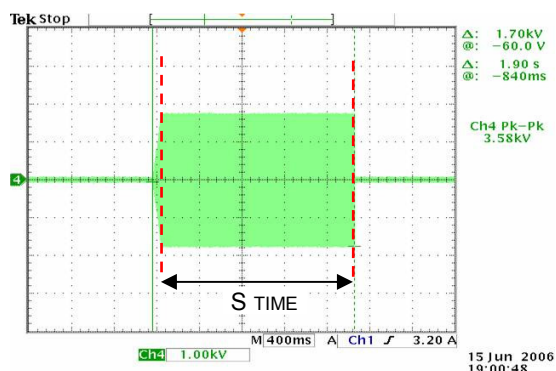
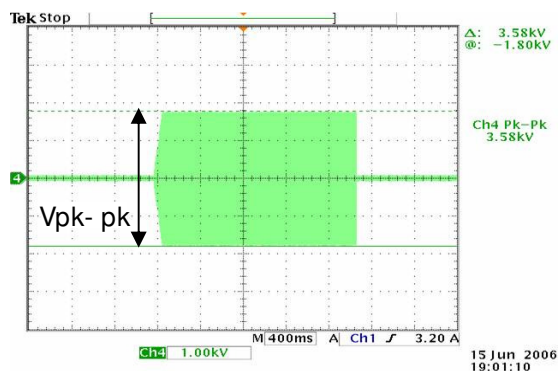

$$V_s = (V_{pk-pk}) / [2 \cdot \sqrt{2}]$$

4. Lamp frequency may produce interference with horizontal synchronous frequency and as a result this may cause beat on the display. Therefore, lamp frequency shall be as away possible from the horizontal synchronous frequency and its harmonics range in order to prevent interference.
5. The brightness of the lamp after lighted for 5minutes is defined as 100%.  
 $T_s$  is the time required for the brightness of the center of the lamp to be not less than 95% at typical current.  
 The screen of LCD module may be partially dark by the time the brightness of lamp is stable after turn on.
6. Maximum level of power consumption is measured at initial turn on.  
 Typical level of power consumption is measured after 2hrs aging at  $25 \pm 2^\circ\text{C}$ .
7. The life time is determined as the time at which brightness of the lamp is 50% compared to that of initial value at the typical lamp current on condition of continuous operating at  $25 \pm 2^\circ\text{C}$ , based on duty 100%.
8. The output of the inverter must have symmetrical(negative and positive) voltage and current waveform (Unsymmetrical ratio is less than 10%). Please do not use the inverter which has not only unsymmetrical voltage and current but also spike wave.

Requirements for a system inverter design, which is intended to achieve better display performance, power efficiency and more reliable lamp characteristics.

It can help increase the lamp lifetime and reduce leakage current.

- a. The asymmetry rate of the inverter waveform should be less than 10%.
- b. The distortion rate of the waveform should be within  $\sqrt{2} \pm 10\%$ .

\* Inverter output waveform had better be more similar to ideal sine wave.

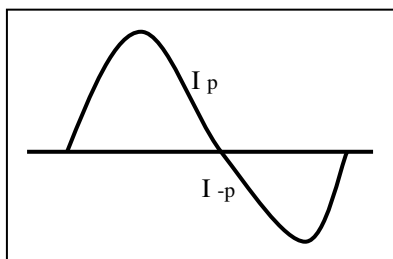

\* Asymmetry rate:

$$|I_p - I_{-p}| / I_{op} \times 100\%$$

\* Distortion rate

$$I_p \text{ (or } I_{-p}) / I_{op}$$



## Product Specification

## 9. The reference method of burst dimming duty ratio.

It is recommended to use synchronous V-sync frequency for prevent waterfall( $V_{sync} \times 1 = \text{Burst Frequency}$ )

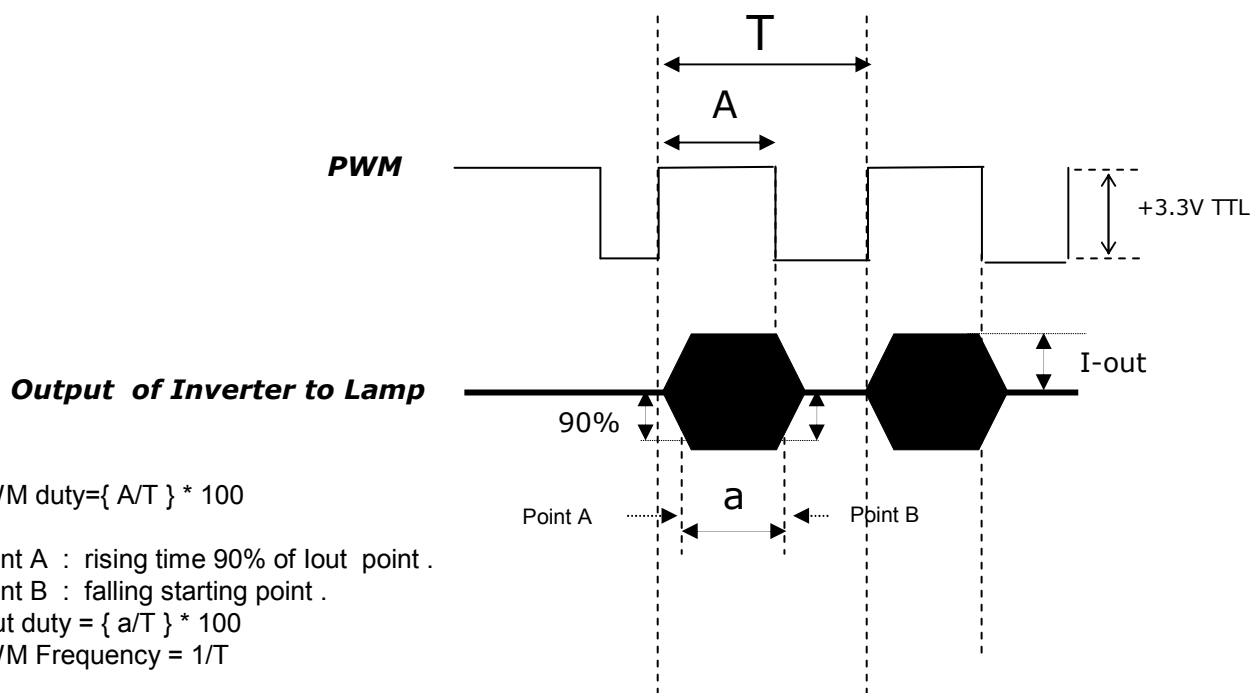

$$\text{PWM duty} = \left\{ \frac{A}{T} \right\} * 100$$

Point A : rising time 90% of  $I_{out}$  point .

Point B : falling starting point .

$$I_{out} \text{ duty} = \left\{ \frac{a}{T} \right\} * 100$$

$$\text{PWM Frequency} = 1/T$$

- ※ We recommend not to be much different between PWM duty and  $I_{out}$  duty .
- ※ Minimum PWM duty ratio should be defined based on the minimum luminance.
- ※ Dimming current output rising and falling time may produce humming and inverter trans' sound noise.
- ※ Burst dimming duty should be 100% for 1second after turn on
- ※ Equipment
  - Oscilloscope : TDS3054B(Tektronix)
  - Current Probe : P6022 AC (Tektronix)
  - High Voltage Probe: P5100(Tektronix)

10. The Cable between the backlight connector and its inverter power supply should be connected directly with a minimized length. The longer cable between the backlight and the inverter may cause the lower luminance of lamp and may require more higher starting voltage (  $V_s$  ).

11. The operating current must be measured as near as backlight assembly input.

12. The operating current unbalance between left and right must be under typ  $\pm 10\%$ .

13. The measurement method of  $V_{BL}$  &  $I_{BL}$  refer to appendix XI.

## Product Specification

**3-2. Interface Connections**

This LCD module employs two kinds of interface connection, 51pin(CN1) and 41pin(CN2) connectors are used for the module electronics and two 3-pin Balance PCB connectors are used for the integral backlight system.

**3-2-1. LCD Module**

- LCD Connector(CN1,CN2): FI-RE51S-HF or Equivalent, Refer to below and next Page Table
- Mating Connector : FI-RE51HL or compatible

**Table 3-1. MODULE CONNECTOR(CN1) PIN CONFIGURATION**

No	Symbol	Description	No	Symbol	Description
1	GND	Ground	27	GND	Ground (Reserved)
2	NC	No Connection	28	RA2N	SECOND CHANNEL A-
3	NC	No Connection	29	RA2P	SECOND CHANNEL A+
4	NC	No Connection	30	RB2N	SECOND CHANNEL B-
5	NC	No Connection	31	RB2P	SECOND CHANNEL B+
6	NC	No Connection	32	RC2N	SECOND CHANNEL C-
7	LVDS Select	'H' = JEIDA , 'L' = VESA	33	RC2P	SECOND CHANNEL C+
8	NC	No Connection	34	GND	Ground
9	NC	No Connection	35	RCLK2N	SECOND CLOCK CHANNEL Clk-
10	NC	No Connection	36	RCLK2P	SECOND CLOCK CHANNEL Clk+
11	GND	Ground	37	GND	Ground
12	RA1N	FIRST CHANNEL A-	38	RD2N	SECOND CHANNEL D-
13	RA1P	FIRST CHANNEL A+	39	RD2P	SECOND CHANNEL D+
14	RB1N	FIRST CHANNEL B-	40	RE2N	SECOND CHANNEL E-
15	RB1P	FIRST CHANNEL B+	41	RE2P	SECOND CHANNEL E+
16	RC1N	FIRST CHANNEL C-	42	GND	Ground
17	RC1P	FIRST CHANNEL C+	43	GND	Ground
18	GND	Ground	44	GND	Ground (NSB)
19	RCLK1N	FIRST CLOCK CHANNEL Clk-	45	GND	Ground
20	RCLK1P	FIRST CLOCK CHANNEL Clk+	46	GND	Ground
21	GND	Ground	47	NC	No connection
22	RD1N	FIRST CHANNEL D-	48	V <sub>LCD</sub>	Power Supply +12.0V
23	RD1P	FIRST CHANNEL D+	49	V <sub>LCD</sub>	Power Supply +12.0V
24	RE1N	FIRST CHANNEL E-	50	V <sub>LCD</sub>	Power Supply +12.0V
25	RE1P	FIRST CHANNEL E+	51	V <sub>LCD</sub>	Power Supply +12.0V
26	GND	Ground	-	-	-

- Notes :
1. All GND(ground) pins should be connected together to the LCD module's metal frame.
  2. All V<sub>LCD</sub> (power input) pins should be connected together.
  3. All Input levels of LVDS signals are based on the IEA 664 Standard.
  4. Specific pins(pin No. #2~#6) are used for internal data process of the LCD module.  
If not used, these pins are no connection.
  5. Specific pins(pin No. #8~#9) are used for Inverter test of the LCD module.  
If not used, these pins are no connection.
  6. Specific pin No. #44 is used for "No signal detection" of system signal interface.  
It should be GND for NSB(No Signal Black) during the system interface signal is not.  
If this pin is "H", LCD Module displays AGP(Auto Generation Pattern).

## Product Specification

- LCD Connector(CN2): FI-RE41S-HF, Refer to below table
- Mating Connector : FI-RE41HL

**Table 3-2. MODULE CONNECTOR(CN2) PIN CONFIGURATION**

No	Symbol	Description	No	Symbol	Description
1	NC	No connection(Reserved)	22	RE3N	Third CHANNEL E-
2	NC	No connection	23	RE3P	Third CHANNEL E+
3	NC	No connection	24	GND	Ground
4	NC	No connection	25	GND	Ground
5	NC	No connection	26	RA4N	Fourth CHANNEL A-
6	NC	No connection	27	RA4P	Fourth CHANNEL A+
7	NC	No connection	28	RB4N	Fourth CHANNEL B-
8	NC	No connection	29	RB4P	Fourth CHANNEL B+
9	GND	Ground	30	RC4N	Fourth CHANNEL C-
10	RA3N	Third CHANNEL A-	31	RC4P	Fourth CHANNEL C+
11	RA3P	Third CHANNEL A+	32	GND	Ground
12	RB3N	Third CHANNEL B-	33	RCLK4N	Fourth CLOCK CHANNEL Clk-
13	RB3P	Third CHANNEL B+	34	RCLK4P	Fourth CLOCK CHANNEL Clk+
14	RC3N	Third CHANNEL C-	35	GND	Ground
15	RC3P	Third CHANNEL C+	36	RD4N	Fourth CHANNEL D-
16	GND	Ground	37	RD4P	Fourth CHANNEL D+
17	RCLK3N	Third CLOCK CHANNEL Clk-	38	RE4N	Fourth CHANNEL E-
18	RCLK3P	Third CLOCK CHANNEL Clk+	39	RE4P	Fourth CHANNEL E+
19	GND	Ground	40	GND	Ground
20	RD3N	Third CHANNEL D-	41	GND	Ground
21	RD3P	Third CHANNEL D+	-		

Notes : 1. All GND(ground) pins should be connected together to the LCD module's metal frame.

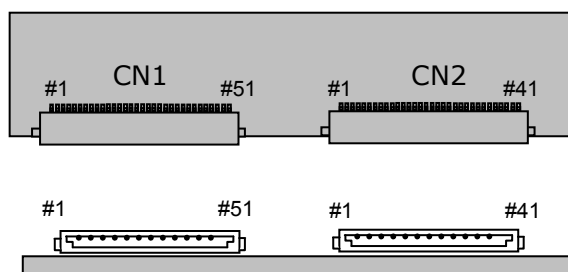
**Rear view of LCM**

[CN1]

- Part/No. : FI-RE51S-HF(JAE)
- Mating connector : FI-RE51HL  
(Manufactured by JAE)

[CN2]

- Part/No. : FI-RE41S-HF(JAE)
- Mating connector : FI-RE41HL  
(Manufactured by JAE)

## Product Specification

## 3-2-2. Backlight Module

**[ Master ]****1) Balance Connector**

: 65002WS-03 (manufactured by YEONHO) or equivalent

**2) Mating Connector**

: 65002HS-03 (manufactured by YEONHO) or equivalent.

**[ Slave ]****1) Balance Connector**

: 65002WS-03 (manufactured by YEONHO) or equivalent

**2) Mating Connector**

: 65002HS-03 (manufactured by YEONHO) or equivalent.

Table 5. BACKLIGHT CONNECTOR PIN CONFIGURATION(CN2,CN3)

No	Symbol	Master	Slave	Note
1	H_Input	High_Input	High_Input	
2	H_Input	High_Input	High_Input	
3	FB	NC	NC	

## ◆ Rear view of LCM

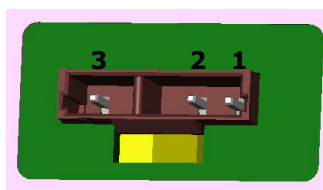

Master

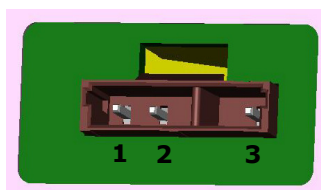

Slave

## Product Specification

**3-3. Signal Timing Specifications**

Table 6 shows the signal timing required at the input of the LVDS transmitter. All of the interface signal timing should be satisfied with the following specification for normal operation.

**Table 6. TIMING TABLE for NTSC/PAL (DE Only Mode)**

ITEM		Symbol	Min	Typ	Max	Unit	Note
Frequency	DCLK	$f_{CLK}$	66.97	74.25	75.00	MHz	
	Horizontal	$f_H$	121.8	135	136.4	KHz	1
	Vertical	$f_V$	95	120	121.2	Hz	1
Horizontal	Display Period	$t_{HV}$	480	480	480	$t_{CLK}$	1920/4
	Blank	$t_{HB}$	40	70	200	$t_{CLK}$	2
	Total	$t_{HP}$	520	550	680	$t_{CLK}$	
Vertical	Display Period	$t_{VV}$	1080	1080	1080	Lines	
	Blank	$t_{VB}$	10	45	300	Lines	2
	Total	$t_{VP}$	1090	1125	1380	Lines	

- Note :
1. The performance of the electro-optical characteristics may be influenced by variance of the vertical refresh rate and the horizontal frequency.
  2. The Input of HSYNC & VSYNC signal does not have an effect on normal operation(DE Only Mode).  
If you use spread spectrum for EMI, add some additional clock to minimum value for clock margin.
  3. Vertical Frequency : NTSC – 108.2~121.2Hz  
PAL – 95~103.7Hz
  4. Waterfall can be shown in the out of PAL/NTSC vertical frequency range.

Product Specification

3-4. Signal Timing Waveforms

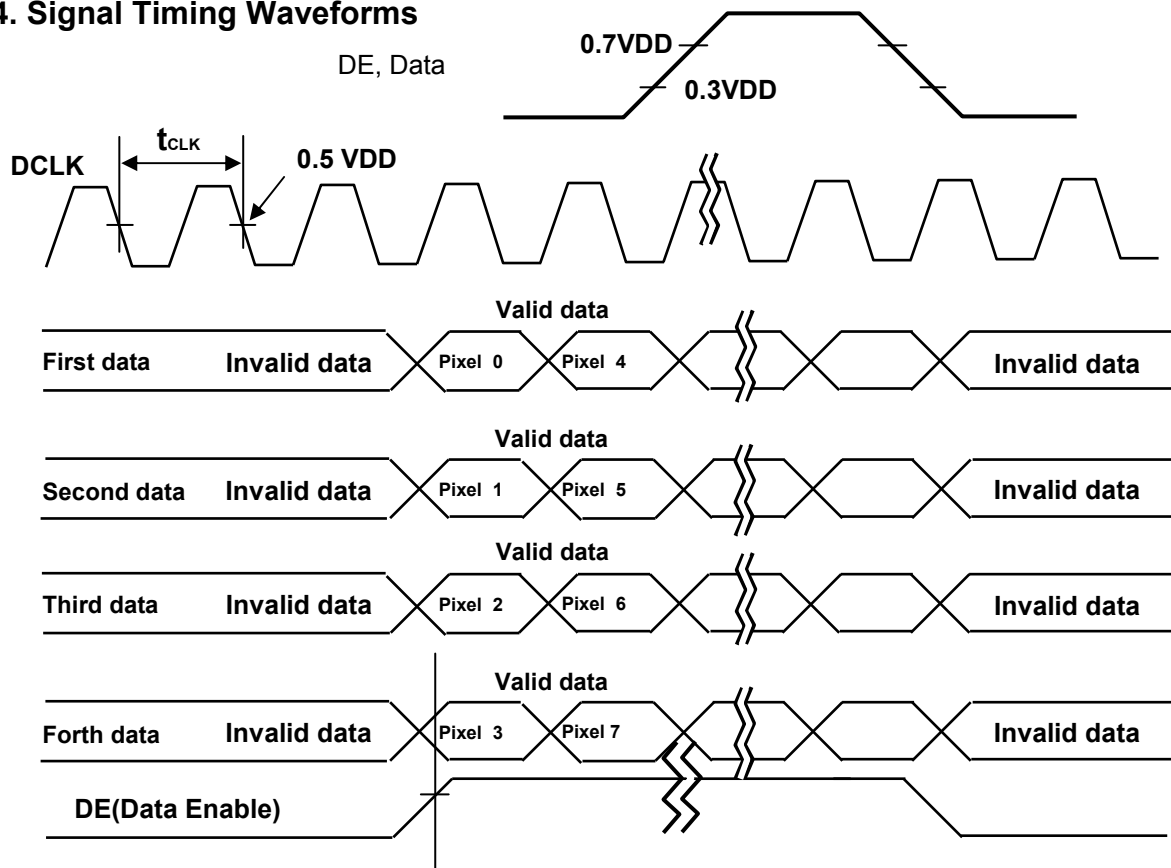

\*  $t_{HB} = t_{HFP} + t_{WH} + t_{HBP}$

\*  $t_{VB} = t_{VFP} + t_{VW} + t_{VBP}$

\* Reference : Sync. Relation

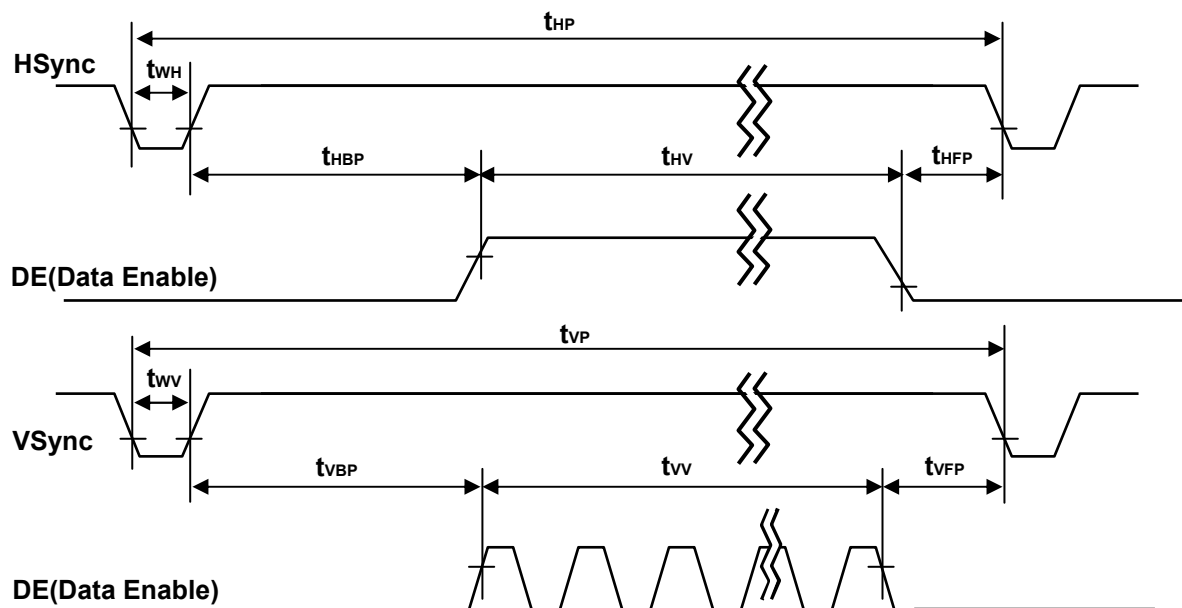

## Product Specification

## 3-5. Color Data Reference

The brightness of each primary color(red,green,blue) is based on the 10bit gray scale data input for the color. The higher binary input, the brighter the color. Table 7 provides a reference for color versus data input.

Table 7. COLOR DATA REFERENCE

Color		Input Color Data																													
		RED										GREEN										BLUE									
		MSB					LSB					MSB					LSB					MSB					LSB				
		R9	R8	R7	R6	R5	R4	R3	R2	R1	R0	G9	G8	G7	G6	G5	G4	G3	G2	G1	G0	B9	B8	B7	B6	B5	B4	B3	B2	B1	B0
Basic Color	Black	0	0	0	0	0	0	0	0	0	0	0	0	0	0	0	0	0	0	0	0	0	0	0	0	0	0	0	0	0	0
	Red (1023)	1	1	1	1	1	1	1	1	1	1	0	0	0	0	0	0	0	0	0	0	0	0	0	0	0	0	0	0	0	0
	Green (1023)	0	0	0	0	0	0	0	0	0	0	1	1	1	1	1	1	1	1	1	1	0	0	0	0	0	0	0	0	0	0
	Blue (1023)	0	0	0	0	0	0	0	0	0	0	0	0	0	0	0	0	0	0	0	0	1	1	1	1	1	1	1	1	1	1
	Cyan	0	0	0	0	0	0	0	0	0	0	1	1	1	1	1	1	1	1	1	1	1	1	1	1	1	1	1	1	1	1
	Magenta	1	1	1	1	1	1	1	1	1	1	0	0	0	0	0	0	0	0	0	0	1	1	1	1	1	1	1	1	1	1
	Yellow	1	1	1	1	1	1	1	1	1	1	1	1	1	1	1	1	1	1	1	1	0	0	0	0	0	0	0	0	0	0
	White	1	1	1	1	1	1	1	1	1	1	1	1	1	1	1	1	1	1	1	1	1	1	1	1	1	1	1	1	1	1
RED	RED (000)	0	0	0	0	0	0	0	0	0	0	0	0	0	0	0	0	0	0	0	0	0	0	0	0	0	0	0	0	0	
	RED (001)	0	0	0	0	0	0	0	0	0	0	0	0	0	0	0	0	0	0	0	0	0	0	0	0	0	0	0	0	0	
	...	...	...	...	...	...	...	...	...	...	...	...	...	...	...	...	...	...	...	...	...	...	...	...	...	...	...	...	...		
	RED (1022)	1	1	1	1	1	1	1	1	1	0	0	0	0	0	0	0	0	0	0	0	0	0	0	0	0	0	0	0	0	
	RED (1023)	1	1	1	1	1	1	1	1	1	0	0	0	0	0	0	0	0	0	0	0	0	0	0	0	0	0	0	0	0	
	GREEN	GREEN (000)	0	0	0	0	0	0	0	0	0	0	0	0	0	0	0	0	0	0	0	0	0	0	0	0	0	0	0	0	0
GREEN (001)		0	0	0	0	0	0	0	0	0	0	0	0	0	0	0	0	0	0	0	0	0	0	0	0	0	0	0	0	0	
...		...	...	...	...	...	...	...	...	...	...	...	...	...	...	...	...	...	...	...	...	...	...	...	...	...	...	...	...		
GREEN (1022)		0	0	0	0	0	0	0	0	0	1	1	1	1	1	1	1	1	1	1	0	0	0	0	0	0	0	0	0	0	
GREEN (1023)		0	0	0	0	0	0	0	0	0	1	1	1	1	1	1	1	1	1	1	0	0	0	0	0	0	0	0	0	0	
BLUE		BLUE (000)	0	0	0	0	0	0	0	0	0	0	0	0	0	0	0	0	0	0	0	0	0	0	0	0	0	0	0	0	0
	BLUE (001)	0	0	0	0	0	0	0	0	0	0	0	0	0	0	0	0	0	0	0	0	0	0	0	0	0	0	0	0	0	
	...	...	...	...	...	...	...	...	...	...	...	...	...	...	...	...	...	...	...	...	...	...	...	...	...	...	...	...	...		
	BLUE (1022)	0	0	0	0	0	0	0	0	0	0	0	0	0	0	0	0	0	0	0	1	1	1	1	1	1	1	1	1	0	
	BLUE (1023)	0	0	0	0	0	0	0	0	0	0	0	0	0	0	0	0	0	0	0	1	1	1	1	1	1	1	1	1	1	

### 3-6. Power Sequence

#### 3-6-1. LCD Driving circuit

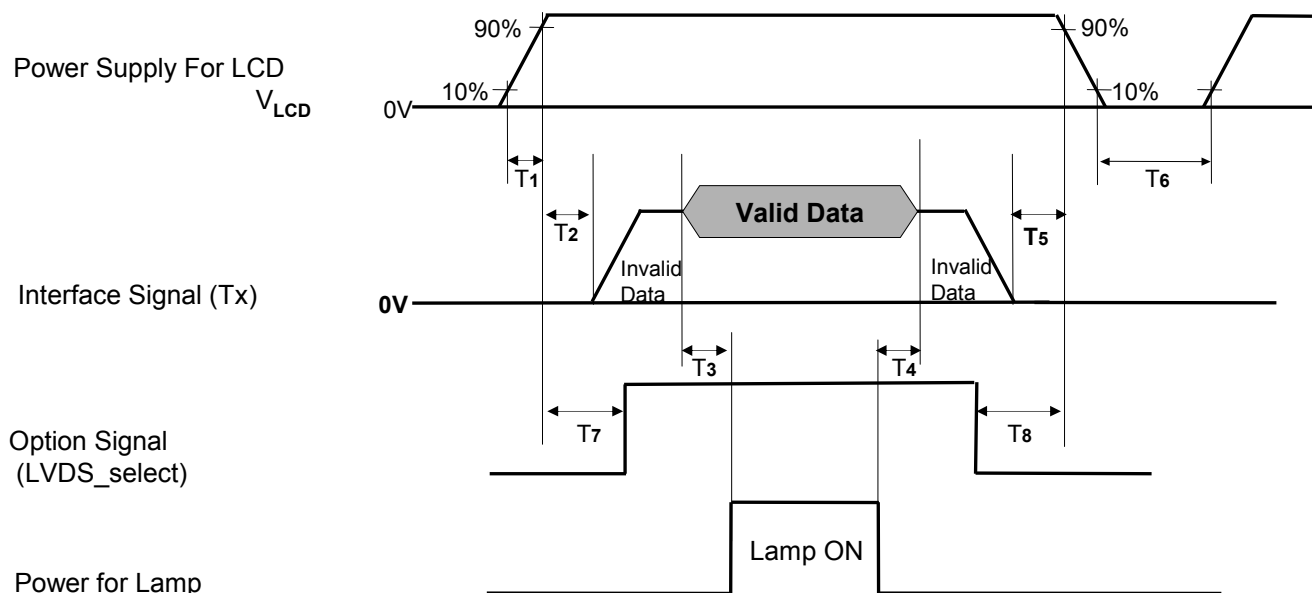

**Table 8. POWER SEQUENCE**

Parameter	Value			Unit	Notes
	Min	Typ	Max		
T1	0.5	-	20	ms	
T2	0	-	-	ms	4
T3	200	-	-	ms	3
T4	200	-	-	ms	3
T5	0	-	-	ms	
T6	2.0	-	-	s	5
T7	0	-	T2	ms	4
T8	0	-	-	ms	4

- Note :
1. Please avoid floating state of interface signal at invalid period.
  2. When the interface signal is invalid, be sure to pull down the power supply  $V_{LCD}$  to 0V.
  3. The T3/T4 is recommended value, the case when failed to meet a minimum specification, abnormal display would be shown. There is no reliability problem.
  4. If the on time of signals (Interface signal and Option signals) precedes the on time of Power ( $V_{LCD}$ ), check the LCD logic Power ( $V_{CC}$ ) is under 0.8V, otherwise it will be happened abnormal display.
  5. T6 should be measured after the Module has been fully discharged between power off and on period.



## Product Specification

#### 4. Optical Specification

Optical characteristics are determined after the unit has been 'ON' and stable in a dark environment at  $25 \pm 2^\circ\text{C}$ . The values specified are at an approximate distance 50cm from the LCD surface at a viewing angle of  $\Phi$  and  $\theta$  equal to  $0^\circ$ .

FIG. 1 shows additional information concerning the measurement equipment and method.

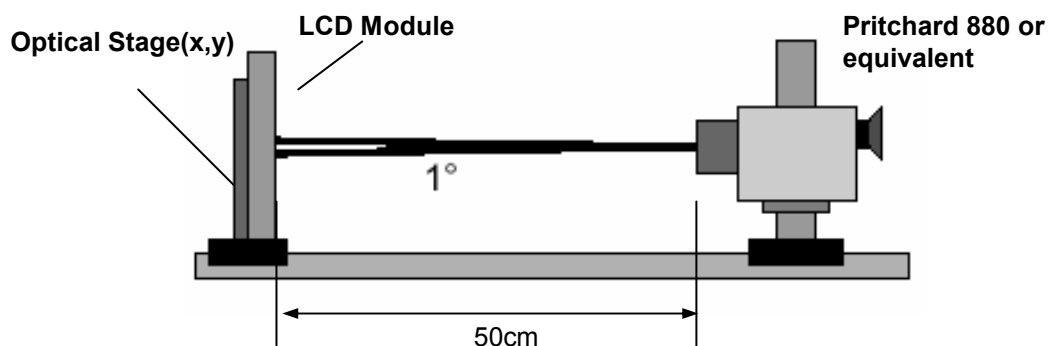

FIG. 1 Optical Characteristic Measurement Equipment and Method

Table 9. OPTICAL CHARACTERISTICS

$T_a = 25 \pm 2^\circ\text{C}$ ,  $V_{LCD} = 12.0\text{V}$ ,  $f_v = 120\text{Hz}$ ,  $D_{clk} = 297\text{MHz}$ ,  $I_{BL} = 135\text{mA}$

Parameter	Symbol	Value			Unit	Note	
		Min	Typ	Max			
Contrast Ratio	CR	900	1300	-		1	
Surface Luminance, white	$L_{WH}$	400	500	-	$\text{cd/m}^2$	2	
Luminance Variation	$\delta_{WHITE}$	5P	-	-	1.3	3	
	$\delta_{BLACK}$	5P	-	-	1.7		
Response Time	Gray-to-Gray	MPRT	-	8	12	ms	4, 5
Color Coordinates [CIE1931]	RED	Rx	Typ -0.03	0.640	Typ +0.03		
		Ry		0.335			
	GREEN	Gx		0.289			
		Gy		0.610			
	BLUE	Bx		0.144			
		By		0.066			
	WHITE	Wx		0.279			
		Wy		0.292			
Viewing Angle (CR>10)							
	x axis, right( $\phi=0^\circ$ )	$\theta_r$	89	-	-	degree	6
	x axis, left ( $\phi=180^\circ$ )	$\theta_l$	89	-	-		
	y axis, up ( $\phi=90^\circ$ )	$\theta_u$	89	-	-		
	y axis, down ( $\phi=270^\circ$ )	$\theta_d$	89	-	-		
Gray Scale			2.2	-			7
Cross Talk					1.8	%	8

## Product Specification

Notes :1. Contrast Ratio(CR) is defined mathematically as :

$$CR_n = \frac{\text{Surface Luminance at all white pixels}}{\text{Surface Luminance at all black pixels}}$$

li is measured at center 1-point.

2. Surface luminance are determined after the unit has been 'ON' and 30min after lighting the backlight in a dark environment at  $25 \pm 2^\circ\text{C}$ . Surface luminance is the luminance value at center 1-point across the LCD surface 50cm from the surface with all pixels displaying white.

For more information see the FIG. 2.

3. The variation in surface luminance ,  $\delta$  WHITE and  $\delta$  BLACK are defined as :

$$\delta \text{ WHITE}(5P) = \text{Maximum}(L_{on1}, L_{on2}, L_{on3}, L_{on4}, L_{on5}) / \text{Minimum}(L_{on1}, L_{on2}, L_{on3}, L_{on4}, L_{on5})$$

$$\delta \text{ BLACK}(5P) = \text{Maximum}(L_{on1}, L_{on2}, L_{on3}, L_{on4}, L_{on5}) / \text{Minimum}(L_{on1}, L_{on2}, L_{on3}, L_{on4}, L_{on5})$$

Where  $L_{on1}$  to  $L_{on5}$  are the luminance with all pixels displaying white at 5 locations .

For more information, see the FIG. 2.

4. Response time is the time required for the display to transition from G(N) to G(M) (Rise Time,  $Tr_R$ ) and from G(M) to G(N) (Decay Time,  $Tr_D$ ). For additional information see the FIG. 3. ( $N < M$ )

5. MPRT is defined as the 10% to 90% blur-edge width  $B_{ij}$ (pixels) and scroll speed  $U$ (pixels/frame)at the moving picture. For more information, see FIG 4.

6. Viewing angle is the angle at which the contrast ratio is greater than 10. The angles are determined for the horizontal or x axis and the vertical or y axis with respect to the z axis which is normal to the LCD module surface. For more information, see the FIG. 5.

7. Gray scale specification

Gamma Value is approximately 2.2. For more information, see the Table 10.

**Table 10. GRAY SCALE SPECIFICATION**

Gray Level	Luminance [%] (Typ.)
L0	0.08
L63	0.22
L127	1.02
L191	2.49
L255	4.71
L319	7.70
L383	11.52
L447	16.18
L511	21.72
L575	28.15
L639	35.51
L703	43.81
L767	53.07
L831	63.30
L895	74.52
L959	86.75
L1023	100

Product Specification

Measuring point for surface luminance & measuring point for luminance variation.

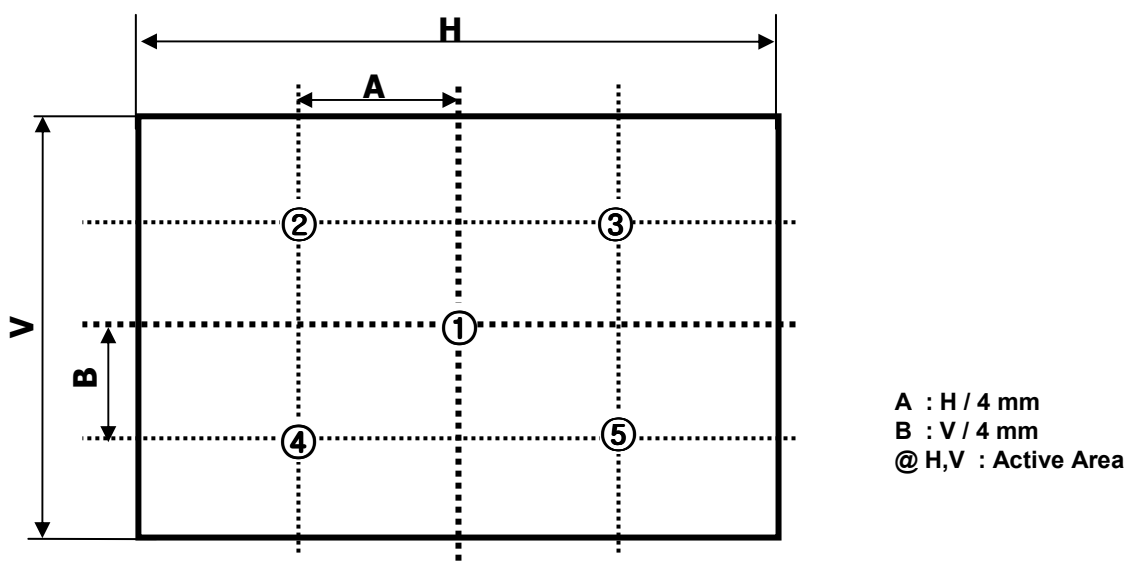

**FIG. 2 5 Points for Luminance Measure**

Response time is defined as the following figure and shall be measured by switching the input signal for "Gray(N)" and "Gray(M)".

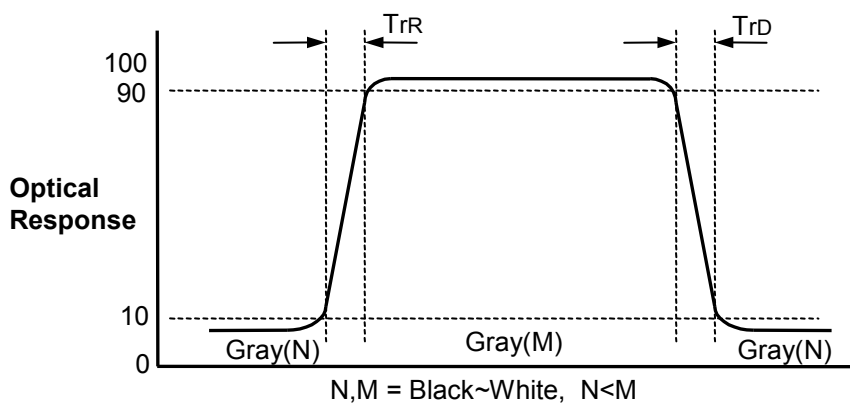

**FIG. 3 Response Time**

Product Specification

MPRT is defined as the 10% to 90% blur-edge with  $B_{ij}$ (pixels) and scroll speed  $U$ (pixels/frame)at the moving picture.

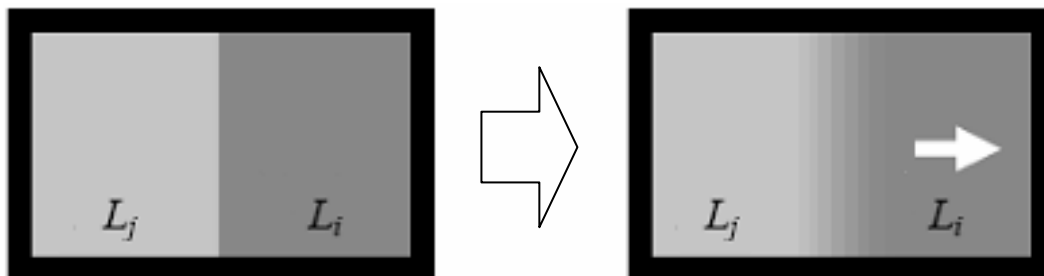

$$M = \frac{1}{U} B_{ij} \quad (i \neq j)$$

Example)  $B_{ij} = 12\text{pixels}$ ,  $U = 10\text{pixels} / 120\text{Hz}$

$$\begin{aligned} M &= 12\text{pixels} / (10\text{pixels} / 120\text{Hz}) \\ &= 12\text{pixels} / \{10\text{pixels} / (1/120)\text{s}\} \\ &= 12 / 1,200 \text{ s} \\ &= 10 \text{ ms} \end{aligned}$$

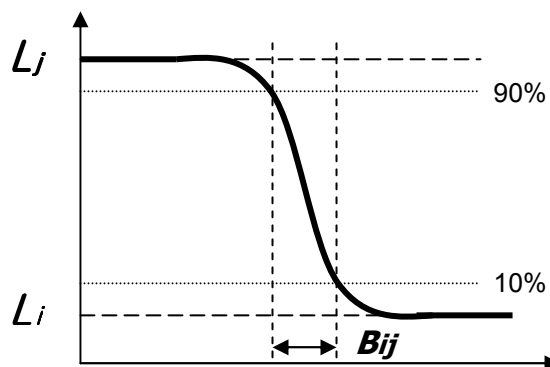

FIG. 4 MPRT

Dimension of viewing angle range

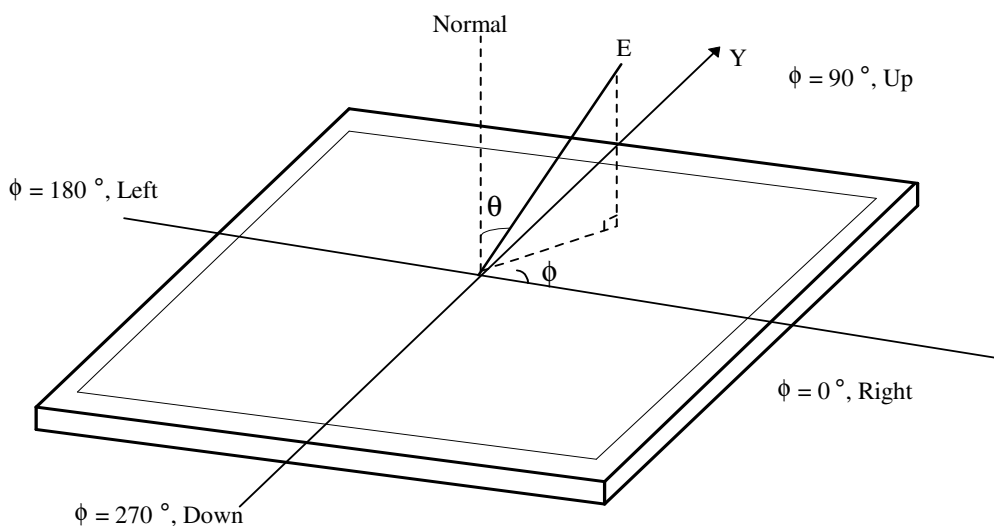

FIG. 5 Viewing Angle

## Product Specification

**5. Mechanical Characteristics**

Table 11 provides general mechanical characteristics.

**Table 11. MECHANICAL CHARACTERISTICS**

Item	Value	
Outline Dimension	Horizontal	983.0 mm
	Vertical	576.0 mm
	Depth	47.3 mm
Bezel Area	Horizontal	939.0 mm
	Vertical	531.0 mm
Active Display Area	Horizontal	930.24 mm
	Vertical	523.26 mm
Weight	11.0 Kg (Typ.) , 12.0Kg (Max.)	

Note : Please refer to a mechanic drawing in terms of tolerance at the next page.

Product Specification

<FRONT VIEW>

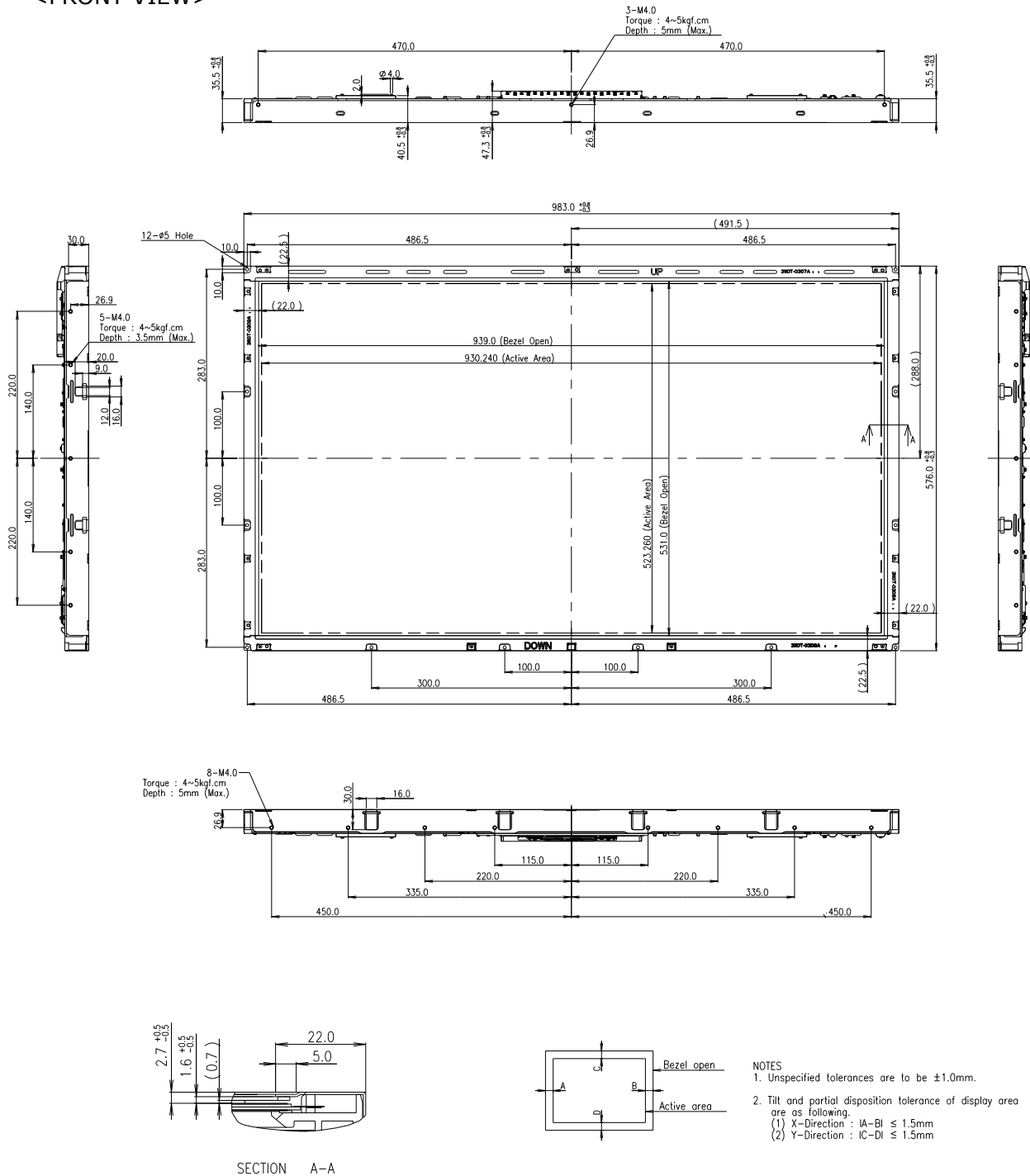

Product Specification

<REAR VIEW>

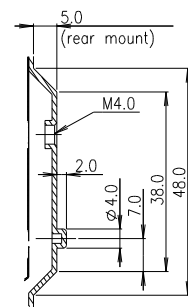
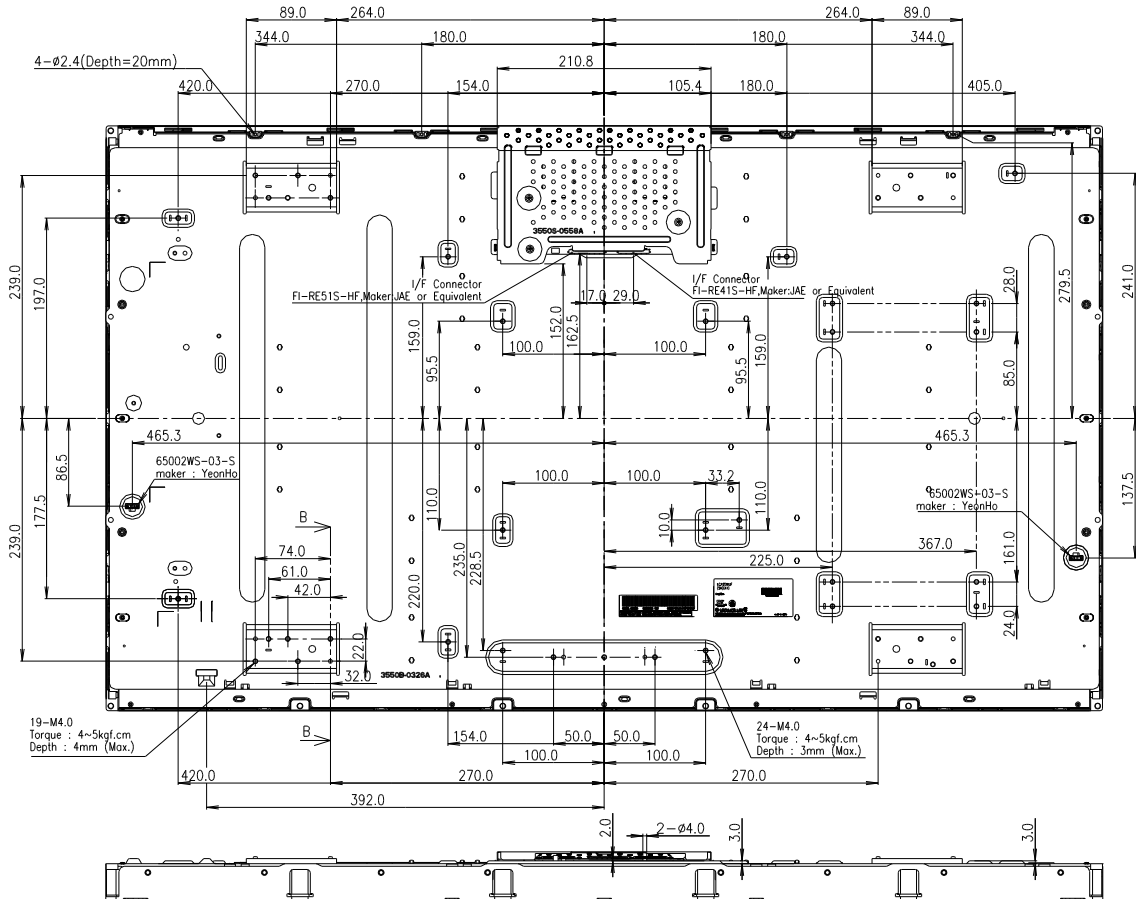

SECTION B-B

## Product Specification

**6. Reliability****Table 12. ENVIRONMENT TEST CONDITION**

No.	Test Item	Condition
1	High temperature storage test	Ta= 60°C, 75%RH, 240h
2	Low temperature storage test	Ta= -20°C 240h
3	High temperature operation test	Ta= 50°C 60%RH 240h
4	Low temperature operation test	Ta= 0°C 240h
5	Vibration test (non-operating)	Wave form : random Vibration level : 1.0Grms Bandwidth : 10-300Hz Duration : X,Y,Z, 30 min One time each direction
6	Shock test (non-operating)	Shock level : 50G Waveform : half sine wave, 11ms Direction : ± X, ± Y, ± Z One time each direction
7	ESD test	Condition : 150pF, 330 ohm Case , air Evaluation : ± 15kV
8	Humidity condition Operation	Ta= 40 °C ,90%RH
9	Altitude operating storage / shipment	0 - 15,000 ft 0 - 40,000 ft

Note : Before and after Reliability test, LCM should be operated with normal function.



## 7. International Standards

### 7-1. Safety

- a) UL 60065, 7<sup>th</sup> Edition, dated June 30, 2003, Underwriters Laboratories, Inc., Standard for Audio, Video and Similar Electronic Apparatus.
- b) CAN/CSA C22.2, No. 60065:03, Canadian Standards Association, Standard for Audio, Video and Similar Electronic Apparatus.
- c) IEC60065:2001, 7<sup>th</sup> Edition CB-scheme and EN 60065:2002, Safety requirements for Audio, Video and Similar Electronic Apparatus..

### 7-2. EMC

- a) ANSI C63.4 "Methods of Measurement of Radio-Noise Emissions from Low-Voltage Electrical and Electrical Equipment in the Range of 9kHz to 40GHz. "American National Standards Institute(ANSI), 1992
- b) CISPR13 "Limits and Methods of Measurement of Radio interference characteristics of Sound and Television broadcast receivers and associated equipment"  
CISPR22 "Limits and Methods of Measurement of Radio interference characteristics of Information Technology Equipment" International Special Committee on Radio Interference.
- c) EN55013 "Limits and Methods of Measurement of Radio interference characteristics of Sound and Television broadcast receivers and associated equipment"  
EN55022 "Limits and Methods of Measurement of Radio interference characteristics of Information Technology Equipment" European Committee for Electro Technical Standardization.(CENELEC), 1988(Including A1:2000)

## Product Specification

**8. Packing****8-1. Designation of Lot Mark**

a) Lot Mark

A	B	C	D	E	F	G	H	I	J	K	L	M
---	---	---	---	---	---	---	---	---	---	---	---	---

A,B,C : SIZE(INCH)

D : YEAR

F : PANEL CODE

H : ASSEMBLY CODE

E : MONTH

G : FACTORY CODE

I,J,K,L,M : SERIAL NO.

Note

1. YEAR

Year	2001	2002	2003	2004	2005	2006	2007	2008	2009	2010
Mark	1	2	3	4	5	6	7	8	9	0

2. MONTH

Month	Jan	Feb	Mar	Apr	May	Jun	Jul	Aug	Sep	Oct	Nov	Dec
Mark	1	2	4	4	5	6	7	8	9	A	B	C

b) Location of Lot Mark

Serial NO. is printed on the label. The label is attached to the backside of the LCD module.  
This is subject to change without prior notice.

**8-2. Packing Form**

a) Package quantity in one Pallet : 13 pcs

b) Pallet Size : 1140 mm X 990 mm X 810 mm.

## Product Specification

### 9. Precautions

Please pay attention to the followings when you use this TFT LCD module.

#### 9-1. Mounting Precautions

- (1) You must mount a module using specified mounting holes (Details refer to the drawings).
- (2) You should consider the mounting structure so that uneven force (ex. Twisted stress) is not applied to the module. And the case on which a module is mounted should have sufficient strength so that external force is not transmitted directly to the module.
- (3) Please attach the surface transparent protective plate to the surface in order to protect the polarizer. Transparent protective plate should have sufficient strength in order to resist external force.
- (4) You should adopt radiation structure to satisfy the temperature specification.
- (5) Acetic acid type and chlorine type materials for the cover case are not desirable because the former generates corrosive gas of attacking the polarizer at high temperature and the latter causes circuit break by electro-chemical reaction.
- (6) Do not touch, push or rub the exposed polarizers with glass, tweezers or anything harder than HB pencil lead. And please do not rub with dust clothes with chemical treatment. Do not touch the surface of polarizer for bare hand or greasy cloth. (Some cosmetics are detrimental to the polarizer.)
- (7) When the surface becomes dusty, please wipe gently with absorbent cotton or other soft materials like chamois soaks with petroleum benzene. Normal-hexane is recommended for cleaning the adhesives used to attach front / rear polarizers. Do not use acetone, toluene and alcohol because they cause chemical damage to the polarizer.
- (8) Wipe off saliva or water drops as soon as possible. Their long time contact with polarizer causes deformations and color fading.
- (9) Do not open the case because inside circuits do not have sufficient strength.

#### 9-2. Operating Precautions

- (1) The spike noise causes the mis-operation of circuits. It should be lower than following voltage :  
 $V = \pm 200\text{mV}$  (Over and under shoot voltage)
- (2) Response time depends on the temperature. (In lower temperature, it becomes longer.)
- (3) Brightness depends on the temperature. (In lower temperature, it becomes lower.)  
 And in lower temperature, response time (required time that brightness is stable after turned on) becomes longer.
- (4) Be careful for condensation at sudden temperature change. Condensation makes damage to polarizer or electrical contacted parts. And after fading condensation, smear or spot will occur.
- (5) When fixed patterns are displayed for a long time, remnant image is likely to occur.
- (6) Module has high frequency circuits. Sufficient suppression to the electromagnetic interference shall be done by system manufacturers. Grounding and shielding methods may be important to minimize the interference.
- (7) Please do not give any mechanical and/or acoustical impact to LCM. Otherwise, LCM can't be operated its full characteristics perfectly.
- (8) A screw which is fastened up the steels should be a machine screw.  
 (if not, it causes metallic foreign material and deal LCM a fatal blow)
- (9) Please do not set LCD on its edge.
- (10) Partial darkness may happen during 3~5 minutes when LCM is operated initially in condition that luminance is under 40% at low temperature (under 5°C). This phenomenon which disappears naturally after 3~5 minutes is not a problem about reliability but LCD characteristic.

### 9-3. Electrostatic Discharge Control

Since a module is composed of electronic circuits, it is not strong to electrostatic discharge. Make certain that treatment persons are connected to ground through wrist band etc. And don't touch interface pin directly.

### 9-4. Precautions for Strong Light Exposure

Strong light exposure causes degradation of polarizer and color filter.

### 9-5. Storage

When storing modules as spares for a long time, the following precautions are necessary.

- (1) Store them in a dark place. Do not expose the module to sunlight or fluorescent light. Keep the temperature between 5°C and 35°C at normal humidity.
- (2) The polarizer surface should not come in contact with any other object.  
It is recommended that they be stored in the container in which they were shipped.

### 9-6. Handling Precautions for Protection Film

- (1) The protection film is attached to the bezel with a small masking tape.  
When the protection film is peeled off, static electricity is generated between the film and polarizer.  
This should be peeled off slowly and carefully by people who are electrically grounded and with well ion-blown equipment or in such a condition, etc.
- (2) When the module with protection film attached is stored for a long time, sometimes there remains a very small amount of glue still on the bezel after the protection film is peeled off.
- (3) You can remove the glue easily. When the glue remains on the bezel surface or its vestige is recognized, please wipe them off with absorbent cotton waste or other soft material like chamois soaked with normal-hexane.

## # APPENDIX-I-1

## ■ Required signal assignment for Flat Link (Thine : THC63LVD103) Transmitter(Pin7="L")

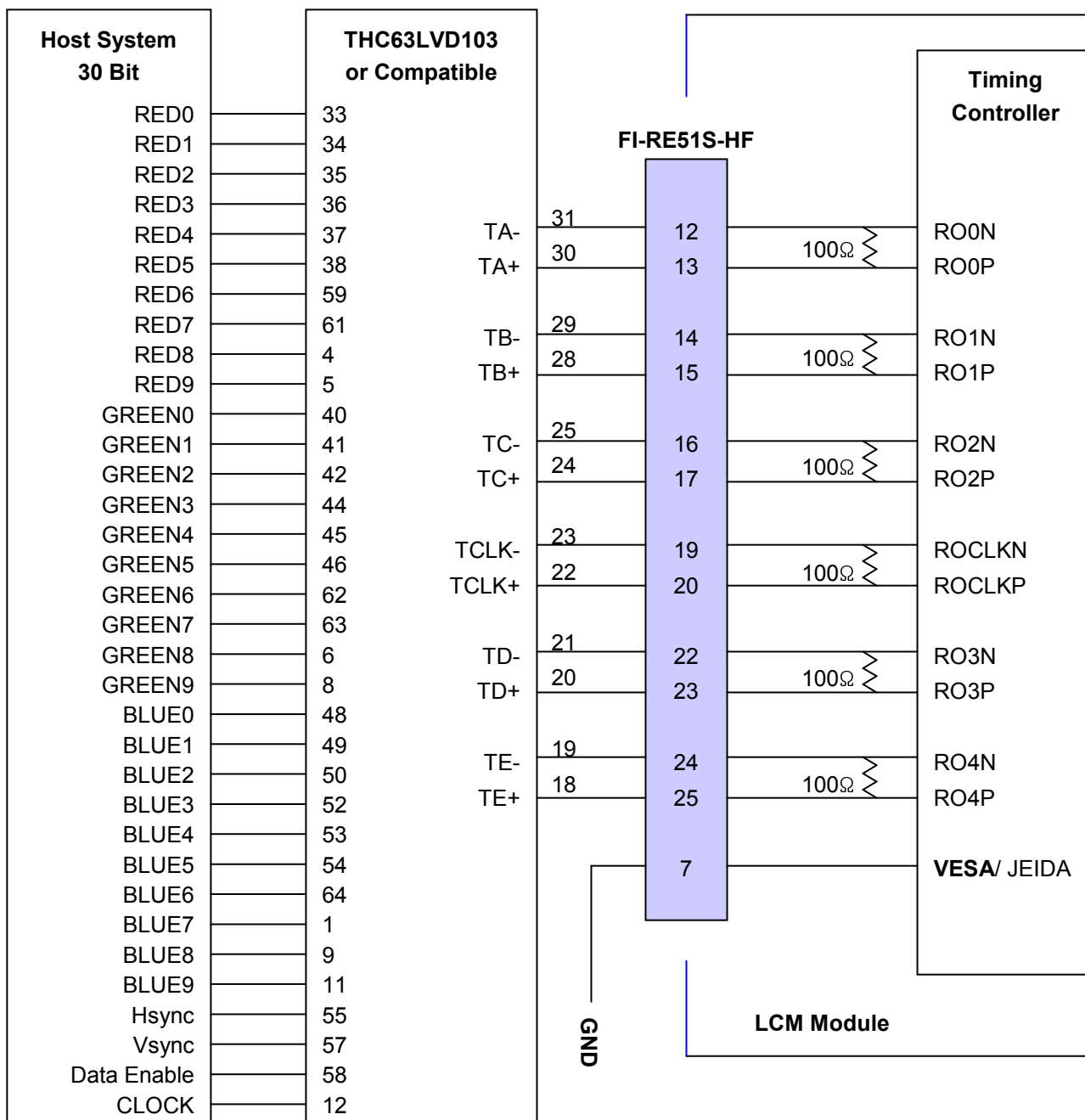

Notes :1. The LCD module uses a 100 Ohm[Ω] resistor between positive and negative lines of each receiver input.

2. Refer to LVDS Transmitter Data Sheet for detail descriptions. (THC63LVD103 or Compatible)

3. '9' means MSB and '0' means LSB at R,G,B pixel data.

## # APPENDIX-I-2

## ■ Required signal assignment for Flat Link (Thine : THC63LVD103) Transmitter(Pin7="H")

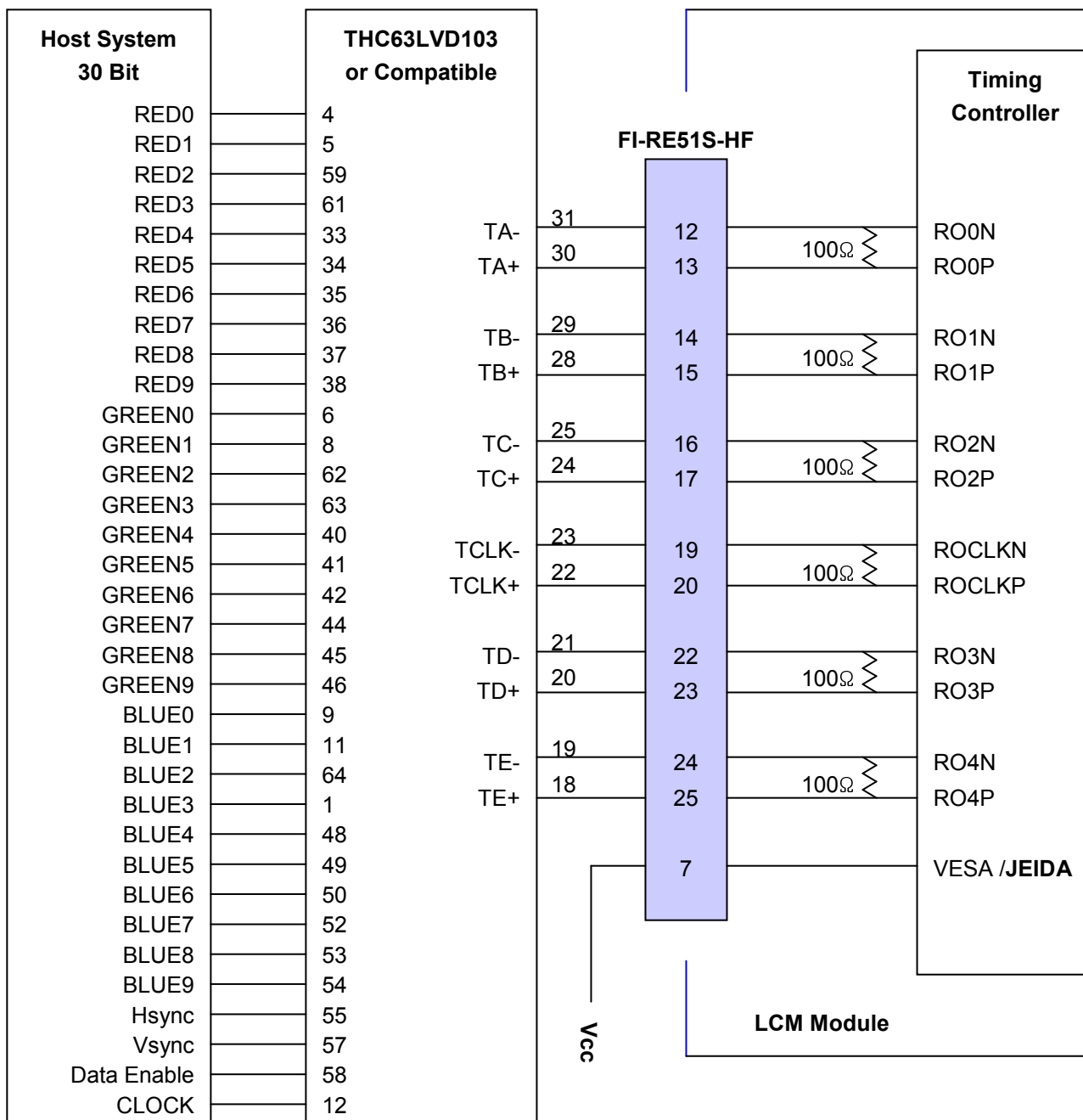

Notes :1. The LCD module uses a 100 Ohm[Ω] resistor between positive and negative lines of each receiver input.

2. Refer to LVDS Transmitter Data Sheet for detail descriptions. (THC63LVD103 or Compatible)

3. '9' means MSB and '0' means LSB at R,G,B pixel data.

## Product Specification

## # APPENDIX-II

## ■ Pallet Ass'y

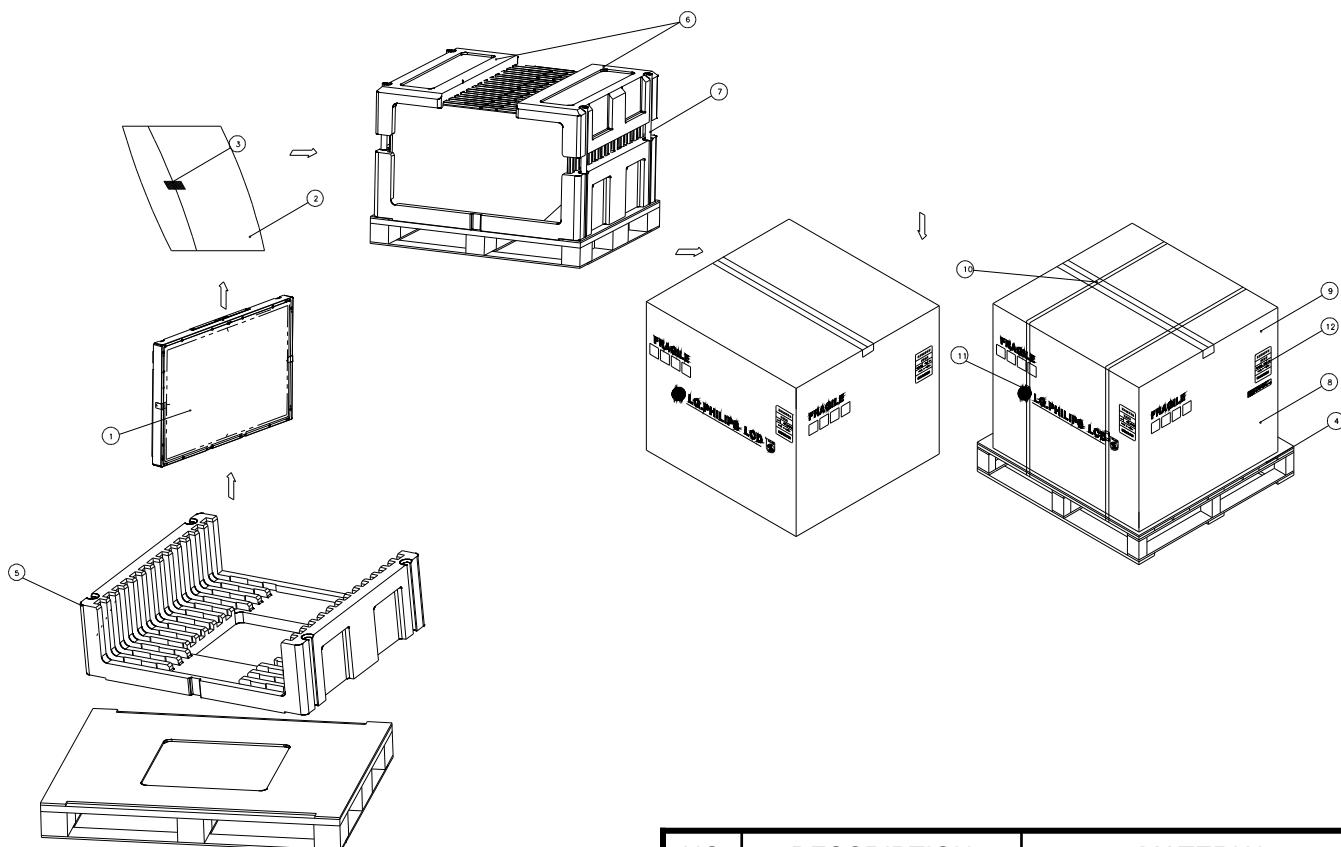

NO.	DESCRIPTION	MATERIAL
1	LCD Module	
2	BAG	42INCH
3	TAPE	MASKING 20MMX50M
4	PALLET	PAPER 1140X990X130MM
5	PACKING,BOTTOM	EPS
6	PACKING, TOP	EPS
7	ANGLE,POST	PAPER
8	ANGLE,PACKING	PAPER
9	BAND,CLIP	STEEL
10	BAND	PP
11	LABEL	YUPO 80G 100X100

# APPENDIX- III

■ LCM Label

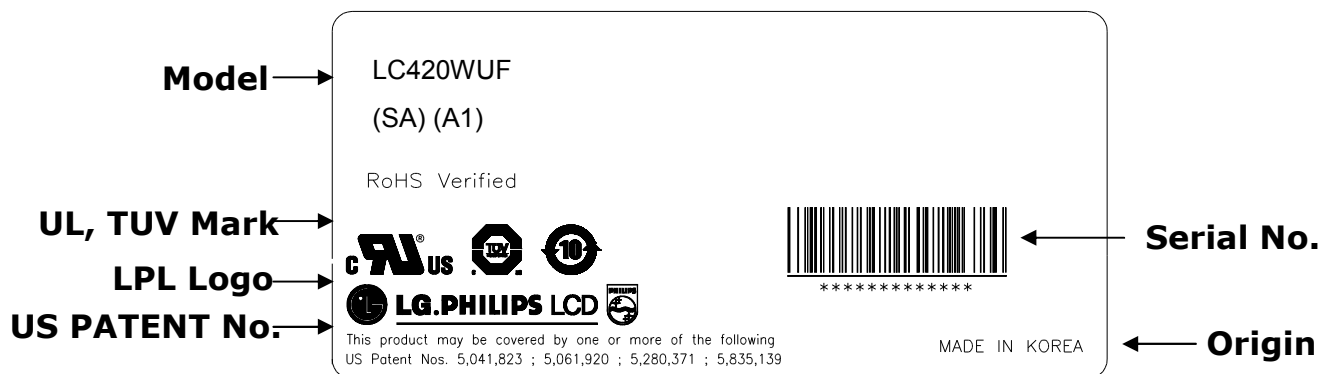

■ Serial No. (See CAS 27page for more information)

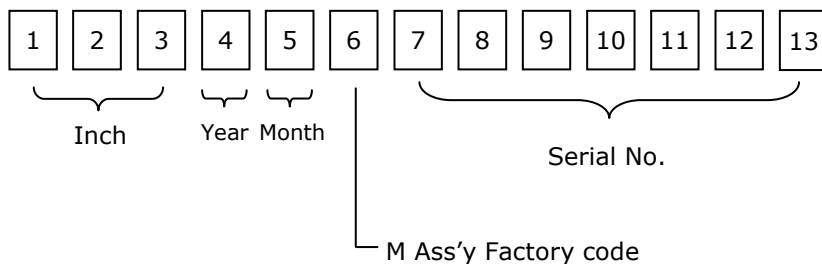



# APPENDIX- IV

■ Pallet Label

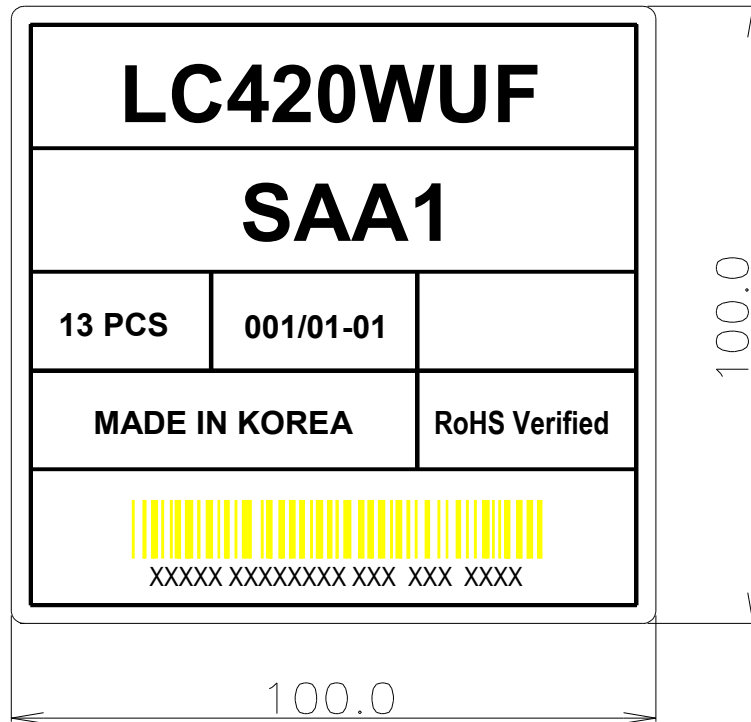

## Product Specification

## # APPENDIX- V

## ■ Lamp Electrical spec

	Item	Unit	Standards		Notes
			Frequency	Characteristics	
1	Lamp Voltage $V_L$	$V_{rms}$	45kHz	1,640± 10% $I_L=3.0mA$ (25℃) 2,030± 10% $I_L=7.0mA$ (25℃) 2,100± 10% $I_L=7.5mA$ (25℃) 2,180± 10% $I_L=8.0mA$ (25℃)	1, 3
2	Lamp Current $I_L$	$mA_{rms}$		Min 3.0 Typ 7.0 Max 8.0	1, 3
3	Lamp power $V_L \times I_L$	W	45kHz	4.5 $I_L=3.0mA$ 9.0 $I_L=7.0mA$ 9.4 $I_L=7.5mA$ 9.8 $I_L=8.0mA$	1, 3
4	Starting Voltage	$V_{rms}$	45kHz	MAX 2,370 (0℃) MAX 1,980 (25℃)	2
5	Discharge Stabilization Time	min		3	3, 4
6	Operating Frequency	kHz		40~45(Typ)~80	5

- Note
- 1) Started at  $I_L=7.0mA$  and measure 3 minutes later.
  - 2) Voltage at switch on. Inverter output voltage.
  - 3) Ambient Temperature should be  $25 \pm 1^\circ C$  under no wind.
  - 4) The time needed to achieve not less than 95% luminance of the center / center part of lamp. The center / center part of lamp shall be measured. The luminance of the lamp after lighted for 5minutes is defined as 100%.
  - 5) The frequency range can be keep within  $\pm 10\%$  range of optical characteristics. (except the chromaticity)

## # APPENDIX- VI

## LVDS Data-Mapping info. (10bit)

## ■ LVDS Select : "H" Data-Mapping (JEIDA format)

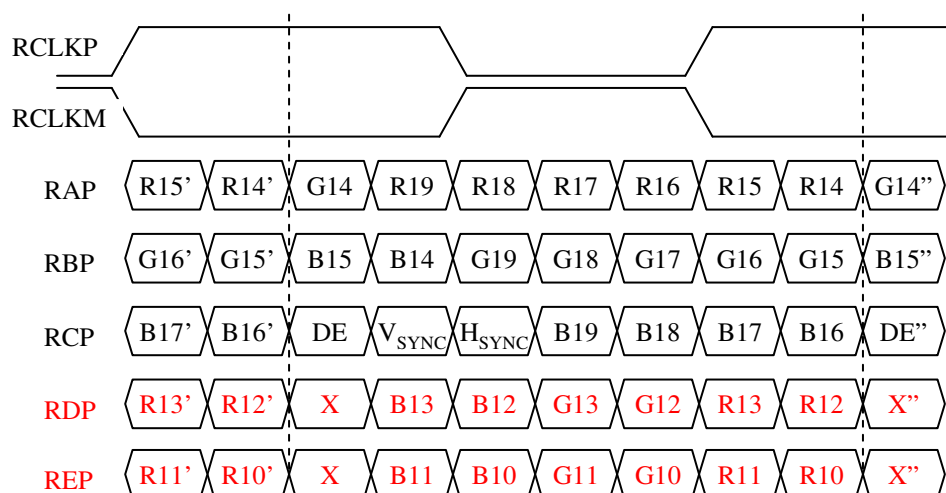

## ■ LVDS Select : "L" Data-Mapping (VESA format)

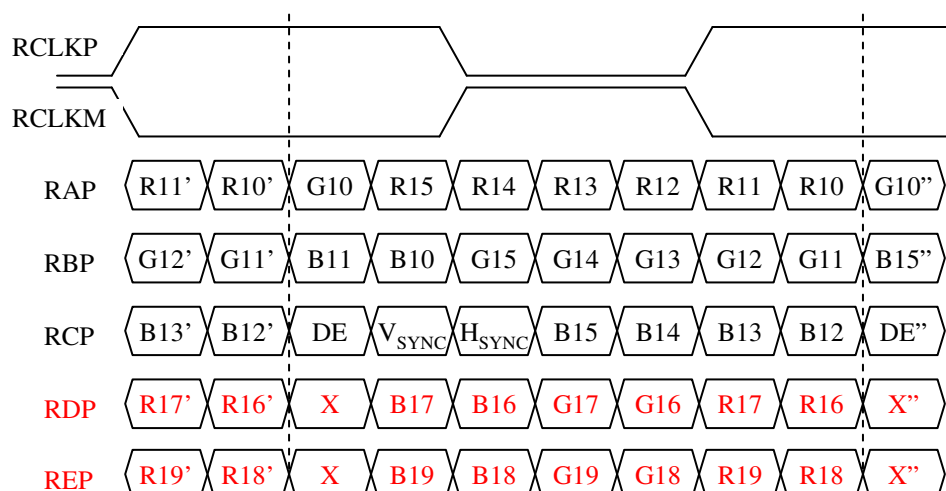

Product Specification

# APPENDIX- VII

### LVDS Input characteristics

1. DC Specification

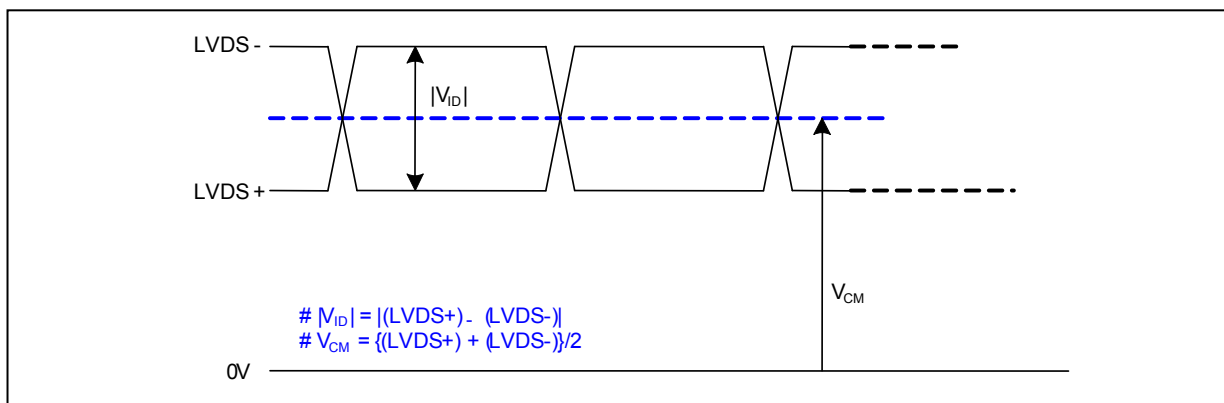

Description	Symbol	Min	Max	Unit	Notes
LVDS Differential Voltage	V <sub>ID</sub>	200	500	mV	-
LVDS Common mode Voltage	V <sub>CM</sub>	1.0	1.5	V	-

2. AC Specification

1) LVDS Clock to data timing

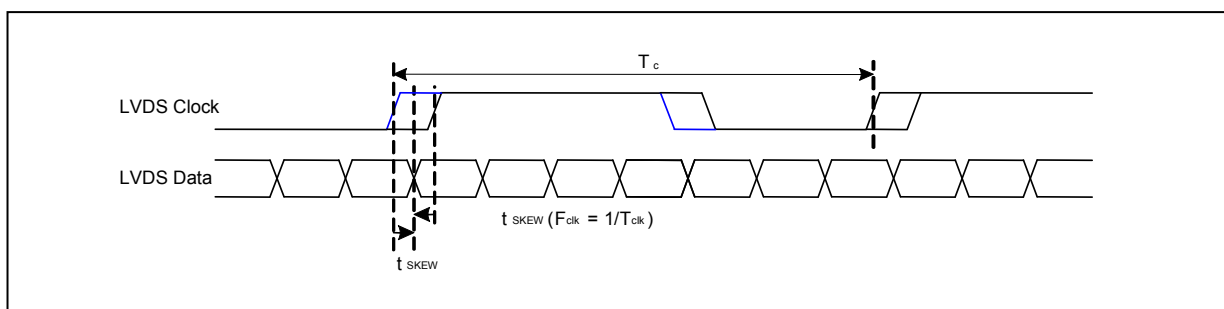

Description	Symbol	Min	Max	Unit	Notes
LVDS Clock to Data Skew Margin	t <sub>SKEW</sub>	-(T <sub>c</sub> / 7) * 0.2	+(T <sub>c</sub> / 7) * 0.2	ps	Note 1

Note> 1. If T<sub>c</sub>=13.46ns , t<sub>SKEW</sub> Min= - 480ps Max= + 480ps

## Product Specification

## 2) LVDS Clock timing

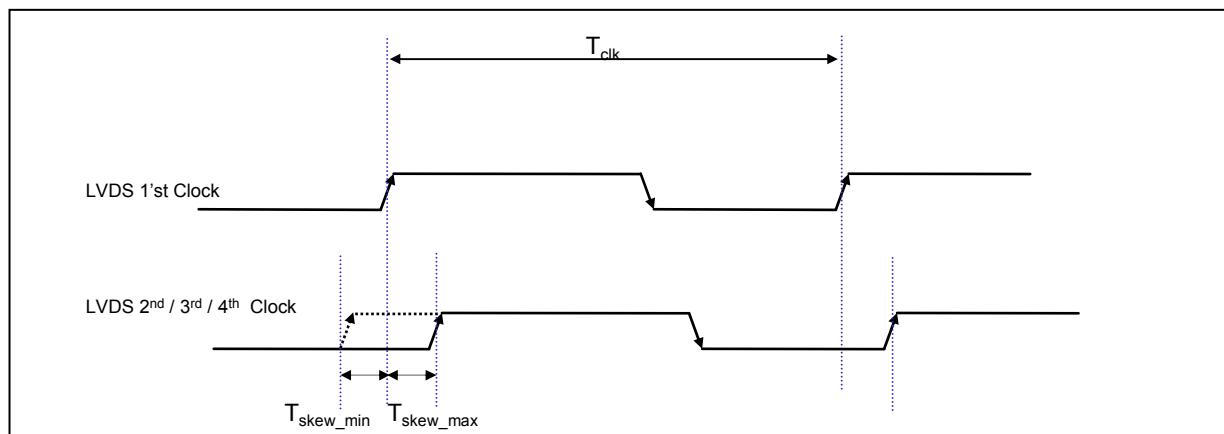

&lt; LVDS inter-port Clock timing &gt;

Description	Symbol	Min	Max	Unit	Notes
LVDS inter-port Clock Skew	$T_{skew}$	-2.5	2.5	ns	-