

Low Current Positive Voltage Regulator

LM78LXXM3

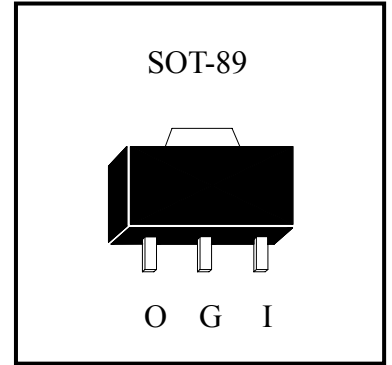

Description

The LM78LXXM3 series of positive regulators are available in the SOT-89 package and with 5V, 6V, 8V, 9V, 10V, 12V, 15V, 18V and 24V fixed output voltages, making it useful in a wide range of applications. These regulators can provide local on-card regulation, eliminating the distribution problems associated with single point regulation. Each type employs internal current limiting, thermal shut-down and safe operating area protection, making it essentially indestructible. If adequate heat sinking is provided, they can deliver over 100mA output current. Although designed primarily as fixed voltage regulators, these devices can be used with external components to obtain adjustable voltages and currents. LM78LXXM3 is characterized for operation from 0°C to 125°C.

Features:

- Internal Short-Circuit Current Limiting
- Internal Thermal Overload Protection
- No External Components Required
- Pb-free package

Typical Application

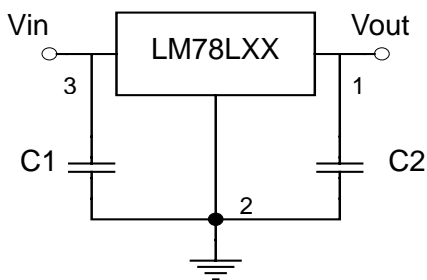

A common ground is required between the input and the output voltages. The input voltage must remain typically 2.0V above the output voltage even during the low point on the input ripple voltage.

Note : C1 and C2 are required if regulator is located far from power supply filter and load, or oscillation may be induced on the loop.

Schematic Diagram

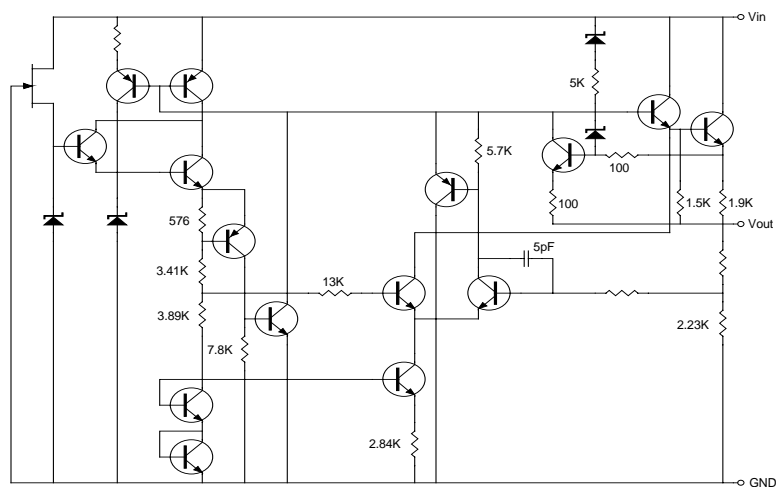



Absolute Maximum Ratings

Parameter	Ratings	Unit
Input Voltage	LM78L05 ~ 10	30
	LM78L12 ~18	35
	LM78L24	40
Output Current	100	mA
Operating Junction Temperature Range	0 ~ 125	°C
Storage Temperature Range	-55 ~ 150	°C
Power Dissipation	350 (Note)	mW

Note : When tested in free air condition, without heat sinking.

Electrical Characteristics

LM78L05 ($V_{in}=10V$, $I_o=40mA$, $T_j=25^\circ C$, $C_{in}=0.33\mu F$, $C_{out}=0.1\mu F$, unless otherwise noted) (Note 1)

Symbol	Parameter	Min	Typ	Max	Conditions	Units
Vo	Output Voltage	4.85	5	5.15	$V_{in}=10V$, $I_o=40mA$, $T_j=25^\circ C$ $7V \leq V_{in} \leq 20V$, $1mA \leq I_o \leq 40mA$	V
		4.75	-	5.25	$7V \leq V_{in} \leq V_{max}$, $1mA \leq I_o \leq 70mA$ (Note 2)	
ΔV_o	Line Regulation	-	18	75	$7V \leq V_{in} \leq 20V$	mV
		-	10	54	$8V \leq V_{in} \leq 20V$	
ΔV_o	Load Regulation	-	20	60	$1mA \leq I_o \leq 100mA$	mV
		-	5	30	$1mA \leq I_o \leq 40mA$	
IQ	Quiescent Current	-	3	5	$T_j=25^\circ C$, $V_{in}=10V$, $I_o=0mA$	mA
ΔIQ	Quiescent Current Change	-	-	1	$8V \leq V_{in} \leq 20V$	mA
		-	-	0.1	$1mA \leq I_o \leq 40mA$	
Vn	Output Noise Voltage	-	40	-	$10Hz \leq f \leq 100KHz$	μV
$\Delta V_{in} / \Delta V_{out}$	Ripple Rejection	47	62	-	$8V \leq V_{in} \leq 20V$, $f=120Hz$	dB
$\Delta V_o / \Delta T_j$	Temperature Stability	-	-0.65	-	$I_o=5mA$, $0^\circ C \leq T_j \leq 125^\circ C$	mV/°C
VD	Dropout Voltage	-	1.7	-	$I_o=100mA$	V

LM78L06 ($V_{in}=12V$, $I_o=40mA$, $T_j=25^\circ C$, $C_{in}=0.33\mu F$, $C_{out}=0.1\mu F$, unless otherwise noted) (Note 1)

Symbol	Parameter	Min	Typ	Max	Conditions	Units
Vo	Output Voltage	5.82	6	6.18	$V_{in}=12V$, $I_o=40mA$, $T_j=25^\circ C$ $8.5V \leq V_{in} \leq 20V$, $1mA \leq I_o \leq 40mA$	V
		5.70	-	6.30	$8.5V \leq V_{in} \leq V_{max}$, $1mA \leq I_o \leq 70mA$ (Note 2)	
ΔV_o	Line Regulation	-	64	175	$8.5V \leq V_{in} \leq 20V$	mV
		-	54	125	$9V \leq V_{in} \leq 20V$	
ΔV_o	Load Regulation	-	12.8	80	$1mA \leq I_o \leq 100mA$	mV
		-	5.8	40	$1mA \leq I_o \leq 70mA$	
IQ	Quiescent Current	-	3.9	6	$T_j=25^\circ C$, $V_{in}=12V$, $I_o=0mA$	mA
ΔIQ	Quiescent Current Change	-	-	1.5	$9V \leq V_{in} \leq 20V$	mA
		-	-	0.1	$1mA \leq I_o \leq 40mA$	
Vn	Output Noise Voltage	-	49	-	$10Hz \leq f \leq 100KHz$	μV
$\Delta V_{in} / \Delta V_{out}$	Ripple Rejection	40	46	-	$10V \leq V_{in} \leq 20V$, $f=120Hz$	dB
$\Delta V_o / \Delta T_j$	Temperature Stability	-	0.75	-	$I_o=5mA$, $0^\circ C \leq T_j \leq 125^\circ C$	mV/°C
VD	Dropout Voltage	-	1.7	-	$I_o=100mA$	V



LM78L08($V_{in}=14V$, $I_o=40mA$, $T_j=25^{\circ}C$, $C_{in}=0.33\mu F$, $C_{out}=0.1\mu F$, unless otherwise noted) (Note 1)

Symbol	Parameter	Min	Typ	Max	Conditions	Units
Vo	Output Voltage	7.76	8	8.24	$V_{in}=14V$, $I_o=40mA$, $T_j=25^{\circ}C$ $10.5V \leq V_{in} \leq 23V$, $1mA \leq I_o \leq 40mA$	V
		7.60	-	8.40	$10.5V \leq V_{in} \leq V_{max}$, $1mA \leq I_o \leq 70mA$ (Note 2)	
ΔV_o	Line Regulation	-	10	175	$10.5V \leq V_{in} \leq 23V$	mV
		-	8	125	$11V \leq V_{in} \leq 23V$	
ΔV_o	Load Regulation	-	15	80	$1mA \leq I_o \leq 100mA$	mV
		-	8	40	$1mA \leq I_o \leq 70mA$	
IQ	Quiescent Current	-	2.0	5.5	$T_j=25^{\circ}C$, $V_{in}=14V$, $I_o=0mA$	mA
ΔIQ	Quiescent Current Change	-	-	1.5	$11V \leq V_{in} \leq 23V$	mA
		-	-	0.1	$1mA \leq I_o \leq 40mA$	
Vn	Output Noise Voltage	-	49	-	$10Hz \leq f \leq 100KHz$	μV
$\Delta V_{in} / \Delta V_{out}$	Ripple Rejection	39	45	-	$11V \leq V_{in} \leq 21V$, $f=120Hz$	dB
$\Delta V_o / \Delta T_j$	Temperature Stability	-	0.75	-	$I_o=5mA$, $0^{\circ}C \leq T_j \leq 125^{\circ}C$	mV/ $^{\circ}C$
VD	Dropout Voltage	-	1.7	-	$I_o=100mA$	V

LM78L09($V_{in}=15V$, $I_o=40mA$, $T_j=25^{\circ}C$, $C_{in}=0.33\mu F$, $C_{out}=0.1\mu F$, unless otherwise noted) (Note 1)

Symbol	Parameter	Min	Typ	Max	Conditions	Units
Vo	Output Voltage	8.73	9	9.27	$V_{in}=15V$, $I_o=40mA$, $T_j=25^{\circ}C$ $11.5V \leq V_{in} \leq 24V$, $1mA \leq I_o \leq 40mA$	V
		8.55	-	9.45	$11.5V \leq V_{in} \leq V_{max}$, $1mA \leq I_o \leq 70mA$ (Note 2)	
ΔV_o	Line Regulation	-	90	200	$11.5V \leq V_{in} \leq 24V$	mV
		-	100	150	$13V \leq V_{in} \leq 24V$	
ΔV_o	Load Regulation	-	20	90	$1mA \leq I_o \leq 100mA$	mV
		-	10	45	$1mA \leq I_o \leq 40mA$	
IQ	Quiescent Current	-	2.0	6.0	$T_j=25^{\circ}C$, $V_{in}=15V$, $I_o=0mA$	mA
ΔIQ	Quiescent Current Change	-	-	1.5	$13V \leq V_{in} \leq 24V$	mA
		-	-	0.1	$1mA \leq I_o \leq 40mA$	
Vn	Output Noise Voltage	-	49	-	$10Hz \leq f \leq 100KHz$	μV
$\Delta V_{in} / \Delta V_{out}$	Ripple Rejection	38	44	-	$12V \leq V_{in} \leq 23V$, $f=120Hz$	dB
$\Delta V_o / \Delta T_j$	Temperature Stability	-	0.75	-	$I_o=5mA$, $0^{\circ}C \leq T_j \leq 125^{\circ}C$	mV/ $^{\circ}C$
VD	Dropout Voltage	-	1.7	-	$I_o=100mA$	V



LM78L10($V_{in}=17V$, $I_o=40mA$, $T_j=25^{\circ}C$, $C_{in}=0.33\mu F$, $C_{out}=0.1\mu F$, unless otherwise noted) (Note 1)

Symbol	Parameter	Min	Typ	Max	Conditions	Units	
V_o	A-rank(3%)	Output Voltage	9.70	10	10.30	$V_{in}=17V$, $I_o=40mA$, $T_j=25^{\circ}C$ $13V \leq V_{in} \leq 25V$, $1mA \leq I_o \leq 40mA$ $13V \leq V_{in} \leq V_{max}$, $1mA \leq I_o \leq 70mA$ (Note 2)	V
	B-rank(5%)		9.50	-	10.50		
ΔV_o	Line Regulation	-	51	175	$13V \leq V_{in} \leq 25V$	mV	
		-	42	125	$14V \leq V_{in} \leq 25V$		
ΔV_o	Load Regulation	-	20	90	$1mA \leq I_o \leq 100mA$	mV	
		-	11	40	$1mA \leq I_o \leq 40mA$		
I_Q	Quiescent Current	-	4.2	6.0	$T_j=25^{\circ}C$, $V_{in}=17V$, $I_o=0mA$	mA	
ΔI_Q	Quiescent Current Change	-	-	1.5	$14V \leq V_{in} \leq 25V$	mA	
		-	-	0.1	$1mA \leq I_o \leq 40mA$		
V_n	Output Noise Voltage	-	62	-	$10Hz \leq f \leq 100KHz$	μV	
$\Delta V_{in} / \Delta V_{out}$	Ripple Rejection	37	44	-	$15V \leq V_{in} \leq 25V$, $f=120Hz$	dB	
$\Delta V_o / \Delta T_j$	Temperature Stability	-	0.75	-	$I_o=5mA$, $0^{\circ}C \leq T_j \leq 125^{\circ}C$	$mV/^{\circ}C$	
V_D	Dropout Voltage	-	1.7	-	$I_o=100mA$	V	

LM78L12 ($V_{in}=19V$, $I_o=40mA$, $T_j=25^{\circ}C$, $C_{in}=0.33\mu F$, $C_{out}=0.1\mu F$, unless otherwise noted) (Note 1)

Symbol	Parameter	Min	Typ	Max	Conditions	Units	
V_o	A-rank(3%)	Output Voltage	11.64	12	12.36	$V_{in}=19V$, $I_o=40mA$, $T_j=25^{\circ}C$ $14.5V \leq V_{in} \leq 27V$, $1mA \leq I_o \leq 40mA$ $14.5V \leq V_{in} \leq V_{max}$, $1mA \leq I_o \leq 70mA$ (Note 2)	V
	B-rank(5%)		11.40	-	12.60		
ΔV_o	Line Regulation	-	25	300	$14.5V \leq V_{in} \leq 27V$	mV	
		-	20	250	$16V \leq V_{in} \leq 27V$		
ΔV_o	Load Regulation	-	25	150	$1mA \leq I_o \leq 100mA$	mV	
		-	12	75	$1mA \leq I_o \leq 40mA$		
I_Q	Quiescent Current	-	2.0	6.0	$T_j=25^{\circ}C$, $V_{in}=19V$, $I_o=0mA$	mA	
ΔI_Q	Quiescent Current Change	-	-	1.5	$16V \leq V_{in} \leq 27V$	mA	
		-	-	0.1	$1mA \leq I_o \leq 40mA$		
V_n	Output Noise Voltage	-	80	-	$10Hz \leq f \leq 100KHz$	μV	
$\Delta V_{in} / \Delta V_{out}$	Ripple Rejection	37	65	-	$15V \leq V_{in} \leq 25V$, $f=120Hz$	dB	
$\Delta V_o / \Delta T_j$	Temperature Stability	-	-1.0	-	$I_o=5mA$, $0^{\circ}C \leq T_j \leq 125^{\circ}C$	$mV/^{\circ}C$	
V_D	Dropout Voltage	-	1.7	-	$I_o=100mA$	V	



LM78L15 ($V_{in}=23V$, $I_o=40mA$, $T_j=25^{\circ}C$, $C_{in}=0.33\mu F$, $C_{out}=0.1\mu F$, unless otherwise noted) (Note 1)

Symbol	Parameter	Min	Typ	Max	Conditions	Units
Vo	Output Voltage	14.55	15	15.45	$V_{in}=23V$, $I_o=40mA$, $T_j=25^{\circ}C$ $17.5V \leq V_{in} \leq 30V$, $1mA \leq I_o \leq 40mA$	V
		14.25	-	15.75	$17.5V \leq V_{in} \leq V_{max}$, $1mA \leq I_o \leq 70mA$ (Note 2)	
ΔV_o	Line Regulation	-	25	150	$17.5V \leq V_{in} \leq 30V$	mV
		-	15	75	$20V \leq V_{in} \leq 30V$	
ΔV_o	Load Regulation	-	20	150	$1mA \leq I_o \leq 100mA$	mV
		-	25	150	$1mA \leq I_o \leq 70mA$	
IQ	Quiescent Current	-	2.2	6.5	$T_j=25^{\circ}C$, $V_{in}=23V$, $I_o=0mA$	mA
ΔIQ	Quiescent Current Change	-	-	1.5	$20V \leq V_{in} \leq 30V$	mA
		-	-	0.1	$1mA \leq I_o \leq 40mA$	
Vn	Output Noise Voltage	-	90	-	$10Hz \leq f \leq 100KHz$	μV
$\Delta V_{in} / \Delta V_{out}$	Ripple Rejection	34	63	-	$18.5V \leq V_{in} \leq 28.5V$, $f=120Hz$	dB
$\Delta V_o / \Delta T_j$	Temperature Stability	-	-1.3	-	$I_o=5mA$, $0^{\circ}C \leq T_j \leq 125^{\circ}C$	mV/ $^{\circ}C$
VD	Dropout Voltage	-	1.7	-	$I_o=100mA$	V

LM78L18 ($V_{in}=27V$, $I_o=40mA$, $T_j=25^{\circ}C$, $C_{in}=0.33\mu F$, $C_{out}=0.1\mu F$, unless otherwise noted) (Note 1)

Symbol	Parameter	Min	Typ	Max	Conditions	Units
Vo	Output Voltage	17.46	18	18.54	$V_{in}=27V$, $I_o=40mA$, $T_j=25^{\circ}C$ $21V \leq V_{in} \leq 33V$, $1mA \leq I_o \leq 40mA$	V
		17.10	-	18.90	$21V \leq V_{in} \leq V_{max}$, $1mA \leq I_o \leq 70mA$ (Note 2)	
ΔV_o	Line Regulation	-	145	300	$21V \leq V_{in} \leq 33V$	mV
		-	135	250	$22V \leq V_{in} \leq 33V$	
ΔV_o	Load Regulation	-	30	170	$1mA \leq I_o \leq 100mA$	mV
		-	15	85	$1mA \leq I_o \leq 40mA$	
IQ	Quiescent Current	-	2.0	6.0	$T_j=25^{\circ}C$, $V_{in}=27V$, $I_o=0mA$	mA
ΔIQ	Quiescent Current Change	-	-	1.5	$21V \leq V_{in} \leq 33V$	mA
		-	-	0.1	$1mA \leq I_o \leq 40mA$	
Vn	Output Noise Voltage	-	150	-	$10Hz \leq f \leq 100KHz$	μV
$\Delta V_{in} / \Delta V_{out}$	Ripple Rejection	34	48	-	$23V \leq V_{in} \leq 33V$, $f=120Hz$	dB
$\Delta V_o / \Delta T_j$	Temperature Stability	-	-1.8	-	$I_o=5mA$, $0^{\circ}C \leq T_j \leq 125^{\circ}C$	mV/ $^{\circ}C$
VD	Dropout Voltage	-	1.7	-	$I_o=100mA$	V



LM78L24 ($V_{in}=33V$, $I_o=40mA$, $T_j=25^{\circ}C$, $C_{in}=0.33\mu F$, $C_{out}=0.1\mu F$, unless otherwise noted) (Note 1)

Symbol	Parameter	Min	Typ	Max	Conditions	Units
Vo	Output Voltage	23.28	24	24.72	$V_{in}=33V$, $I_o=40mA$, $T_j=25^{\circ}C$ $27V \leq V_{in} \leq 38V$, $1mA \leq I_o \leq 40mA$	V
		22.80	24	25.20	$27V \leq V_{in} \leq V_{max}$, $1mA \leq I_o \leq 70mA$ (Note 2)	
ΔV_o	Line Regulation	-	160	300	$27V \leq V_{in} \leq 38V$	mV
		-	150	250	$28V \leq V_{in} \leq 38V$	
ΔV_o	Load Regulation	-	40	200	$1mA \leq I_o \leq 100mA$	mV
		-	20	100	$1mA \leq I_o \leq 40mA$	
IQ	Quiescent Current	-	2.2	6.0	$T_j=25^{\circ}C$, $V_{in}=33V$, $I_o=0mA$	mA
ΔIQ	Quiescent Current Change	-	-	1.5	$27V \leq V_{in} \leq 38V$	mA
		-	-	0.1	$1mA \leq I_o \leq 40mA$	
Vn	Output Noise Voltage	-	200	-	$10Hz \leq f \leq 100KHz$	μV
$\Delta V_{in} / \Delta V_{out}$	Ripple Rejection	34	45	-	$27V \leq V_{in} \leq 38V$, $f=120Hz$	dB
$\Delta V_o / \Delta T_j$	Temperature Stability	-	-2.0	-	$I_o=5mA$, $0^{\circ}C \leq T_j \leq 125^{\circ}C$	$mV/^{\circ}C$
VD	Dropout Voltage	-	1.7	-	$I_o=100mA$	V

Note : 1. The maximum steady state usable output current is dependent on input voltage, heat sinking, lead length of the package and copper of PCB. The data above represent pulse test conditions with junction temperatures specified at the initial of test.

2. Power dissipation < 0.5W

Ordering Information

Device	Output Voltage Tolerance	Package	Shipping	Marking
LM78LXXM3 A-rank	$\pm 3\%$	SOT-89 (Pb-free)	1000 pcs / Tape & Reel	78LXX
LM78LXXM3 B-rank	$\pm 5\%$	SOT-89 (Pb-free)	1000 pcs / Tape & Reel	78LXX

Characteristic Curves

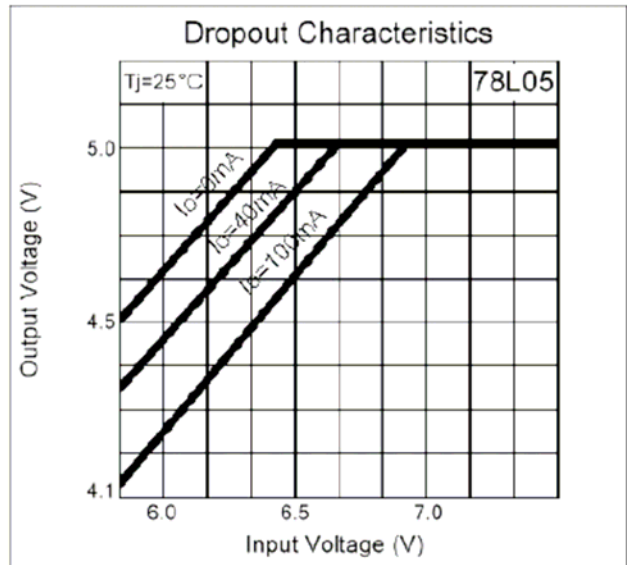
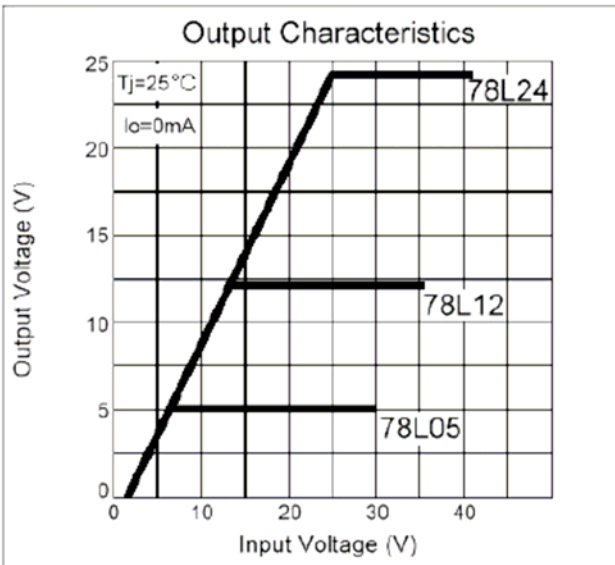
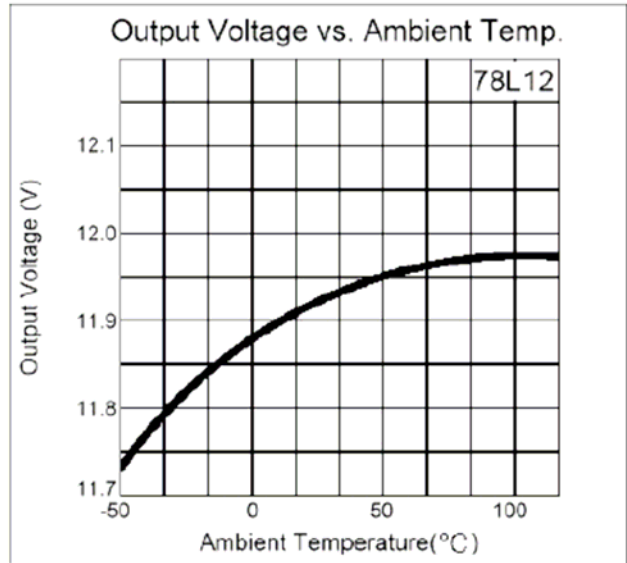
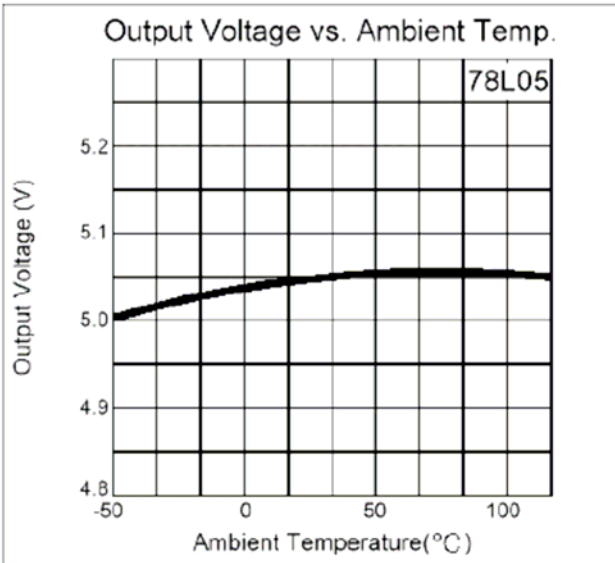

Characteristic Curves(Cont.)

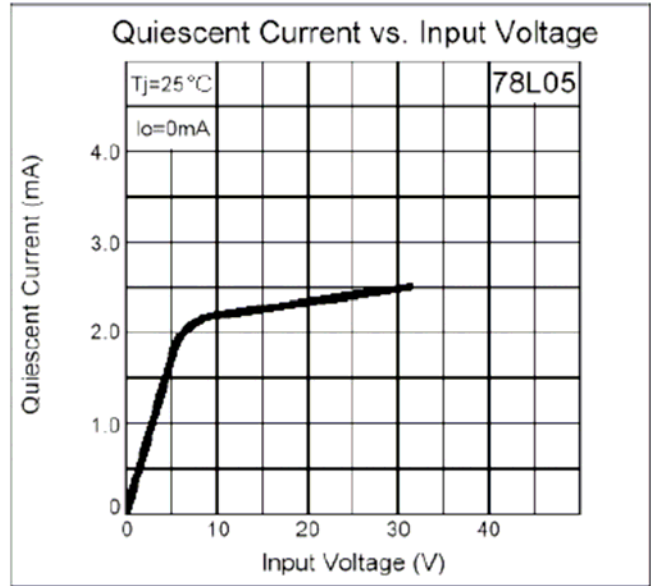
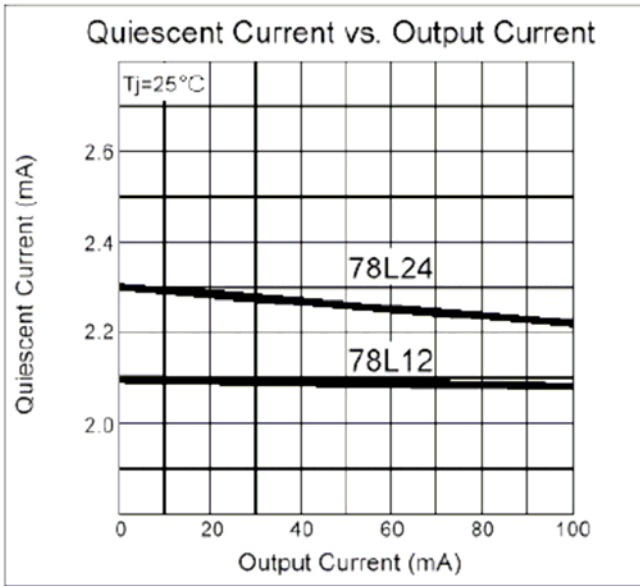

Reel Dimension

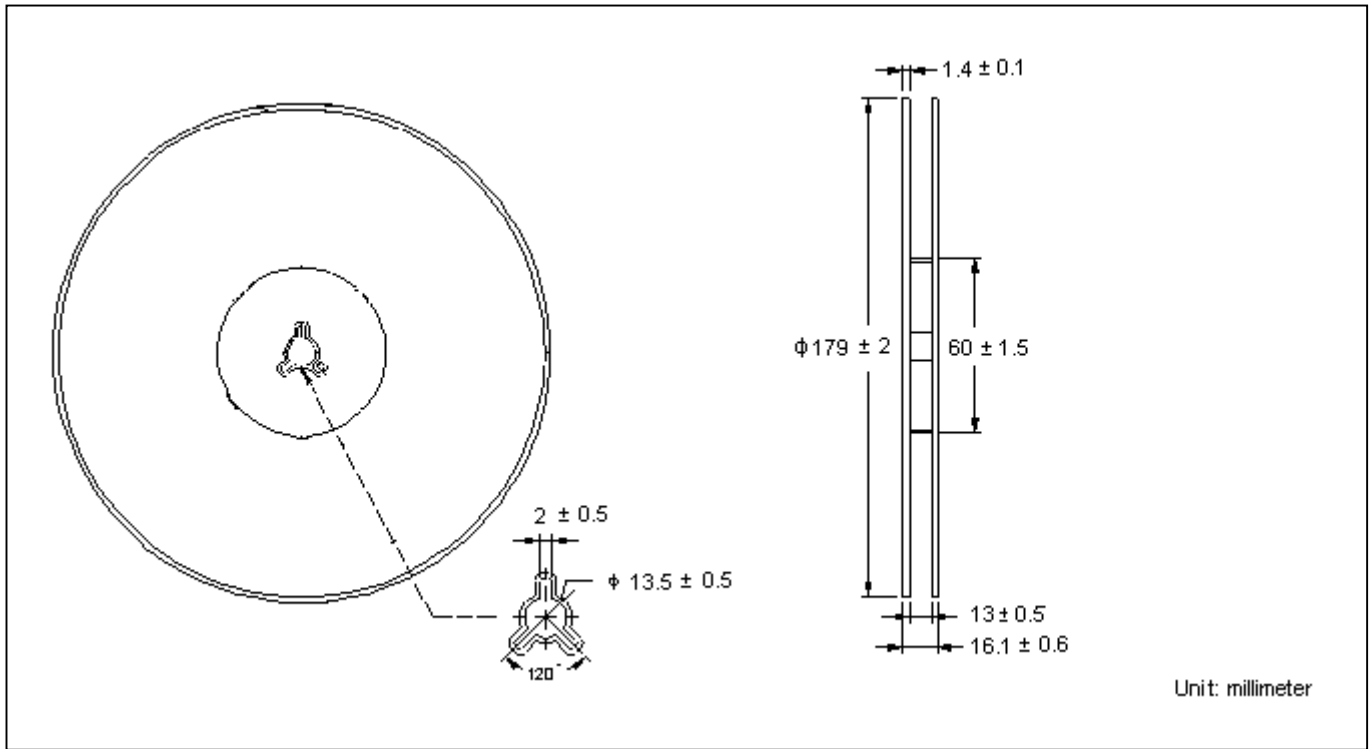

Carrier Tape Dimension

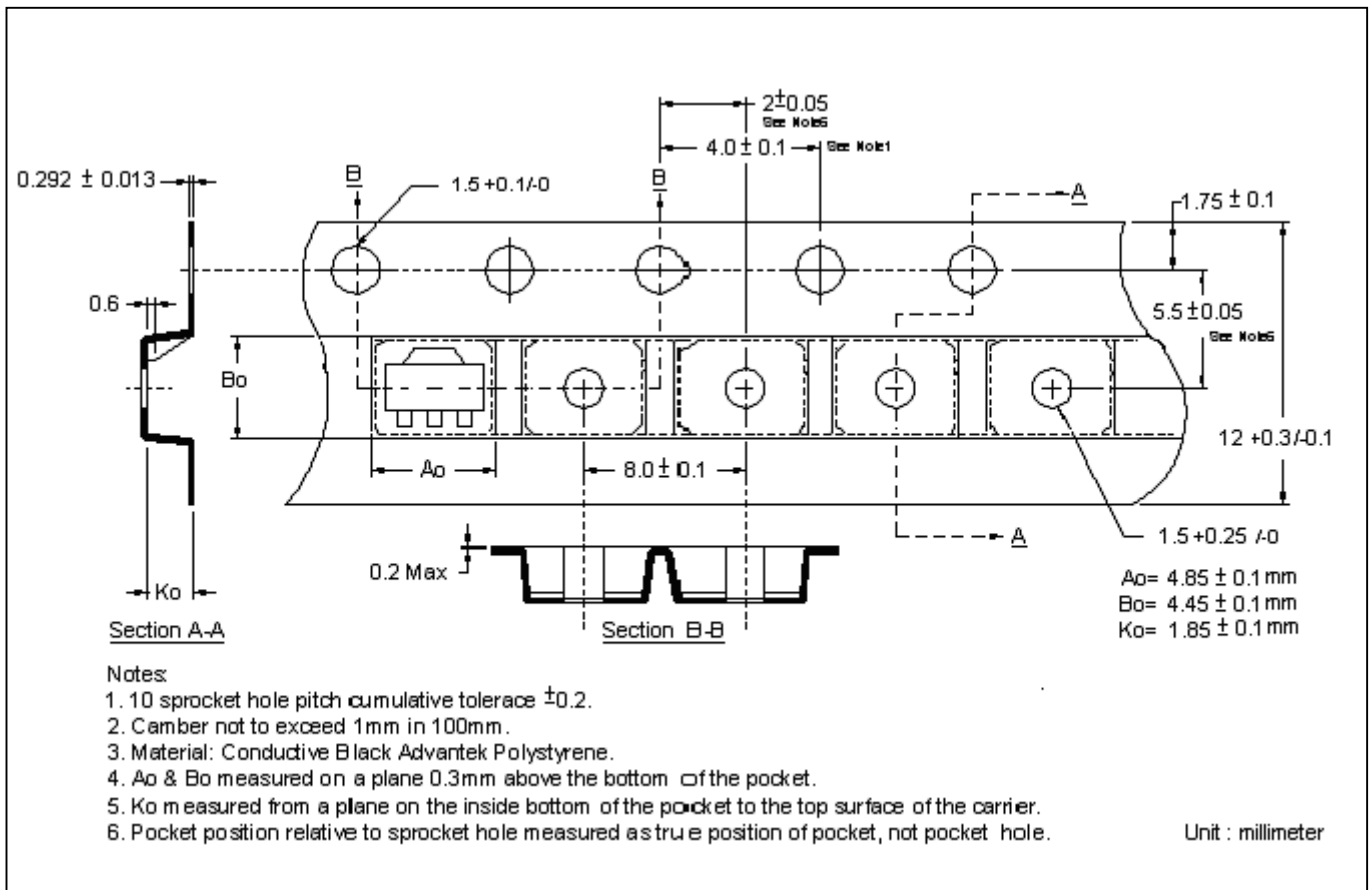

SOT-89 Dimension

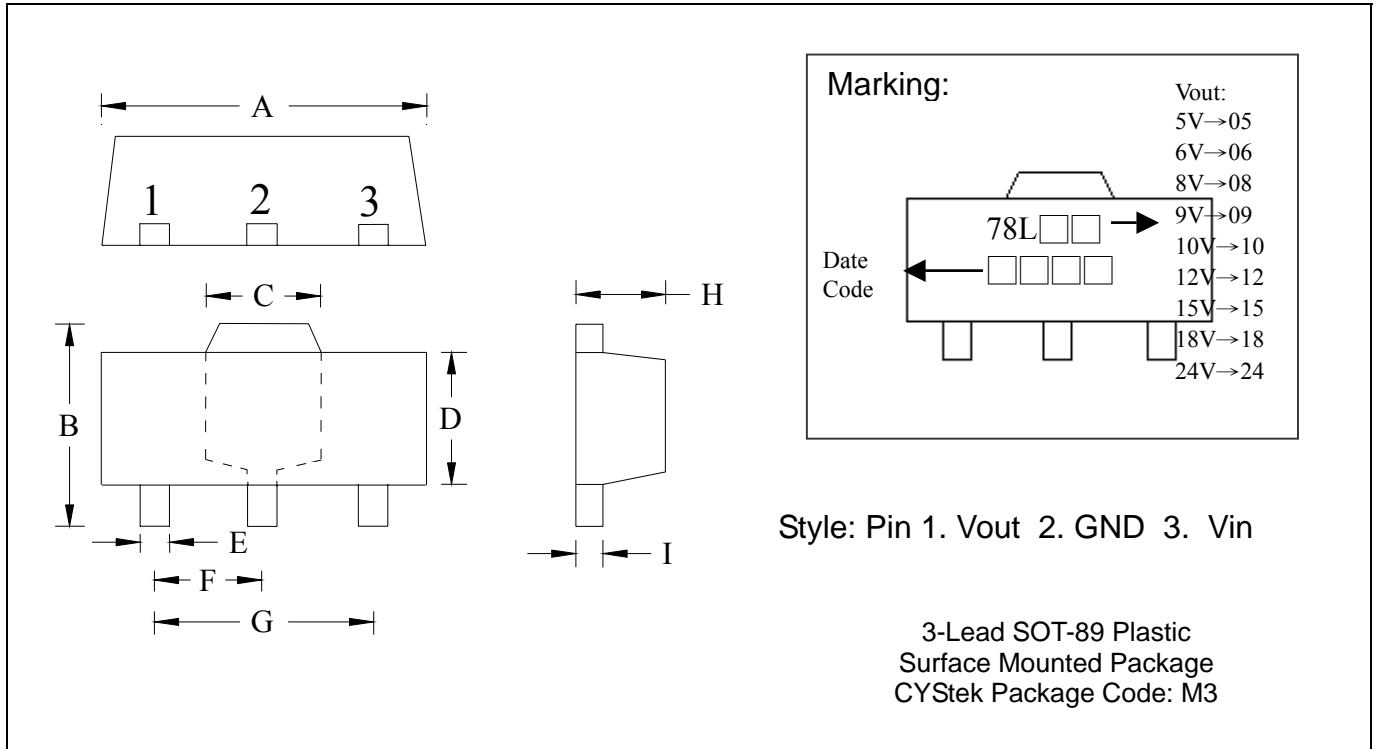

*: Typical

DIM	Inches		Millimeters		DIM	Inches		Millimeters	
	Min.	Max.	Min.	Max.		Min.	Max.	Min.	Max.
A	0.1732	0.1811	4.40	4.60	F	0.0583	0.0598	1.48	1.527
B	0.1594	0.1673	4.05	4.25	G	0.1165	0.1197	2.96	3.04
C	0.0591	0.0663	1.50	1.70	H	0.0551	0.0630	1.40	1.60
D	0.0945	0.1024	2.40	2.60	I	0.0138	0.0161	0.35	0.41
E	0.01417	0.0201	0.36	0.51					

Notes: 1.Controlling dimension: millimeters.
 2.Maximum lead thickness includes lead finish thickness, and minimum lead thickness is the minimum thickness of base material.
 3.If there is any question with packing specification or packing method, please contact your local CYStek sales office.

Material:

- Lead: 42 Alloy ; solder plating
- Mold Compound: Epoxy resin family, flammability solid burning class: UL94V-0

Important Notice:

- All rights are reserved. Reproduction in whole or in part is prohibited without the prior written approval of CYStek.
- CYStek reserves the right to make changes to its products without notice.
- CYStek **semiconductor products are not warranted to be suitable for use in Life-Support Applications, or systems.**
- CYStek assumes no liability for any consequence of customer product design, infringement of patents, or application assistance.