

AME8838

High PSRR, 150mA CMOS LDO

■ General Description

The AME8838 family of positive, linear regulators feature low quiescent current (30 μ A typ.) low dropout voltage and excellent PSRR, thus making them ideal for Telecommunications and other battery applications. The ultra-small SC-70-5, SC-70-4 & SOT-23 packages are attractive for "Pocket" and "Hand Held" applications.

These rugged devices have both Thermal Shutdown and Current limit to prevent device failure under the "Worst" operating conditions.

The AME8838 is stable with an output capacitance of 1 μ F or larger.

■ Features

- Very Low Dropout Voltage
- Guaranteed 150mA Output
- 30 μ A Quiescent Current
- Over-Temperature Shutdown
- Current Limiting
- Excellent PSRR (Typ. 65dB)
- Power-Saving Shutdown Mode
- Ultra-small SC-70-5, SC-70-4 & SOT-23 Packages
- Factory Pre-set Output Voltages
- Low Temperature Coefficient
- Input Voltage Range (2V - 6V)
- All AME's lead free Products Meet RoHS Standard.

■ Applications

- Cellular Phones
- Instrumentation
- Portable Electronics
- Wireless Devices
- Cordless Phones
- PC Peripherals
- Battery Powered Widgets
- Cameras
- Telecommunications

■ Functional Block Diagram

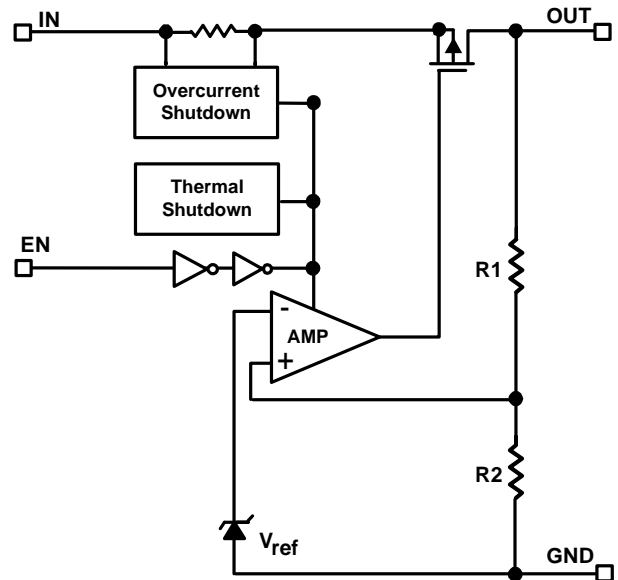

■ Typical Application

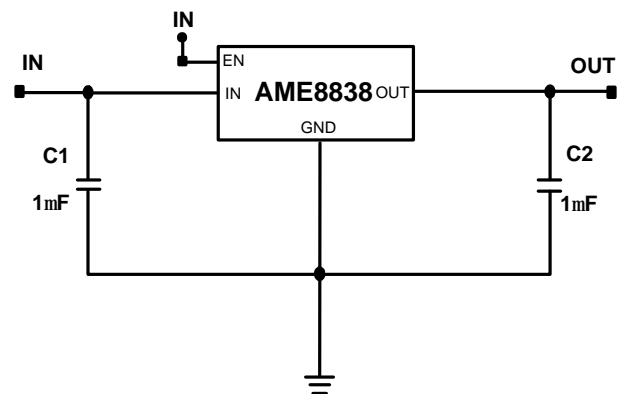

AME8838

High PSRR, 150mA CMOS LDO

■ Pin Configuration

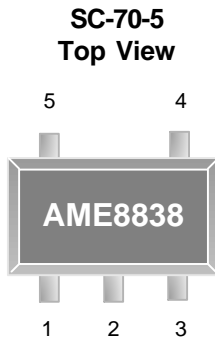

AME8838AEIV

1. IN
2. GND
3. EN
4. NC
5. OUT

*** Die Attach:
Conductive Epoxy**

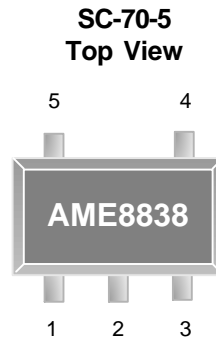

AME8838BEIV

1. OUT
2. GND
3. IN
4. EN
5. NC

*** Die Attach:
Conductive Epoxy**

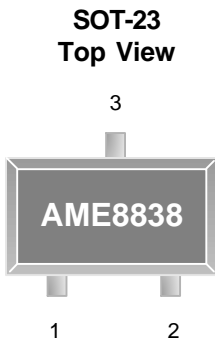

AME8838AEET

1. GND
2. OUT
3. IN

*** Die Attach:
Non-Conductive Epoxy**

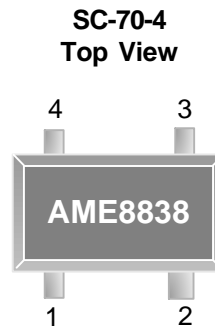

AME8838AEIU

1. EN
2. GND
3. OUT
4. IN

*** Die Attach:
Conductive Epoxy**

AME8838
High PSRR, 150mA CMOS LDO
■ Pin Description
AME8838AEIV SC-70-5

Pin Number	Pin Name	Pin Description
1	IN	Input voltage pin. It should be decoupled with 1 μ F or greater capacitor.
2	GND	Ground connection pin.
3	EN	Enable pin. When pulled low, the PMOS pass transistor turns off, current consuming less than 1 μ A.
4	NC	No Connection.
5	OUT	LDO voltage regulator output pin. It should be decoupled with a 1 μ F or greater value low ESR ceramic capacitor.

AME8838BEIV SC-70-5

Pin Number	Pin Name	Pin Description
1	OUT	LDO voltage regulator output pin. It should be decoupled with a 1 μ F or greater value low ESR ceramic capacitor.
2	GND	Ground connection pin.
3	IN	Input voltage pin. It should be decoupled with 1 μ F or greater capacitor.
4	EN	Enable pin. When pulled low, the PMOS pass transistor turns off, current consuming less than 1 μ A.
5	NC	No Connection.

AME8838AEET SOT-23

Pin Number	Pin Name	Pin Description
1	GND	Ground connection pin.
2	OUT	LDO voltage regulator output pin. It should be decoupled with a 1 μ F or greater value low ESR ceramic capacitor.
3	IN	Input voltage pin. It should be decoupled with 1 μ F or greater capacitor.

AME8838**High PSRR, 150mA CMOS LDO****■ Pin Description**

AME8838AEIU SC-70-4

Pin Number	Pin Name	Pin Description
1	EN	Enable pin. When pulled low, the PMOS pass transistor turns off, current consuming less than 1 μ A.
2	GND	Ground connection pin.
3	OUT	LDO voltage regulator output pin. It should be decoupled with a 1 μ F or greater value low ESR ceramic capacitor.
4	IN	Input voltage pin. It should be decoupled with 1 μ F or greater capacitor.



AME8838

High PSRR, 150mA CMOS LDO

■ **Ordering Information**

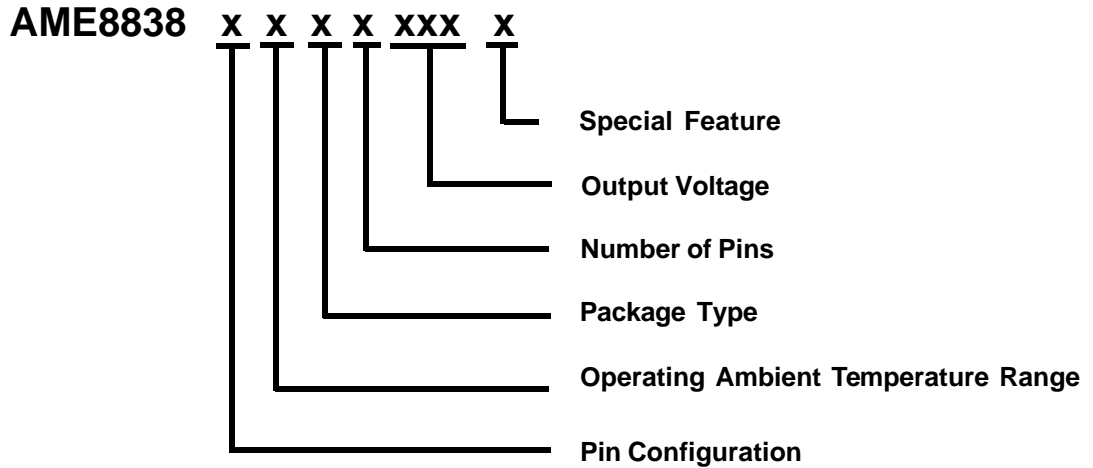

Pin Configuration	Operating Ambient Temperature Range	Package Type	Number of Pins	Output Voltage	Special Feature
A: 1. IN (SC-70-5) 2. GND 3. EN 4. NC 5. OUT B: 1. OUT (SC-70-5) 2. GND 3. IN 4. EN 5. NC A: 1. EN (SC-70-4) 2. GND 3. OUT 4. IN A: 1. GND (SOT-23) 2. OUT (TSOT-23) 3. IN	E: -40°C to 85°C	E: SOT-2X I: SC-70	T: 3 V: 5 U: 4	120: V=1.2V 150: V=1.5V 180: V=1.8V 250: V=2.5V 270: V=2.7V 285: V=2.85V 300: V=3.0V 310: V=3.1V 330: V=3.3V	Y: Lead free & Low profile Z: Lead free



AME8838

High PSRR, 150mA CMOS LDO

■ Ordering Information

Part Number	Marking*	Output Voltage	Package	Operating Ambient Temperature Range
AME8838AEIU180Z	BLFw	1.8V	SC-70-4	- 40°C to 85°C
AME8838AEIU270Z	BLGw	2.7V	SC-70-4	- 40°C to 85°C
AME8838AEIU280Z	BLHw	2.8V	SC-70-4	- 40°C to 85°C
AME8838AEIV150Z	BFDw	1.5V	SC-70-5	- 40°C to 85°C
AME8838AEIV180Z	BELw	1.8V	SC-70-5	- 40°C to 85°C
AME8838AEIV250Z	BFEw	2.5V	SC-70-5	- 40°C to 85°C
AME8838AEIV270Z	BHSw	2.7V	SC-70-5	- 40°C to 85°C
AME8838AEIV280Z	BFFw	2.8V	SC-70-5	- 40°C to 85°C
AME8838AEIV285Z	BHVw	2.85V	SC-70-5	- 40°C to 85°C
AME8838AEIV300Z	BFGw	3.0V	SC-70-5	- 40°C to 85°C
AME8838AEIV310Z	BHTw	3.1V	SC-70-5	- 40°C to 85°C
AME8838AEIV330Z	BEKw	3.3V	SC-70-5	- 40°C to 85°C
AME8838AEET180Z	BFPww	1.8V	SOT-23	- 40°C to 85°C

Note: w & ww represent the date code and pls refer to Date Code Rule page on Package Dimension.

* A line on top of the first letter represents lead free plating such as BLFw.

Please consult AME sales office or authorized Rep./Distributor for the availability of package type.

AME8838
High PSRR, 150mA CMOS LDO
■ Absolute Maximum Ratings

Parameter	Maximum	Unit
Input Voltage	-0.3 to 7	V
EN Voltage	-0.3 to 7	V
Output Voltage	- 0.3 to $V_{IN} + 0.3$	V
Output Current	$P_D / (V_{IN} - V_{OUT})$	mA
ESD Classification	B*	

Caution: Stress above the listed absolute maximum rating may cause permanent damage to the device
HBM B*: 2000V ~ 3999V

■ Recommended Operating Conditions

Parameter	Symbol	Rating	Unit
Ambient Temperature Range	T_A	- 40 to 85	°C
Junction Temperature Range	T_J	- 40 to 125	°C
Storage Temperature Range	T_{STG}	- 65 to 150	°C

■ Thermal Information

Parameter	Package	Die Attach	Symbol	Maximum	Unit
Thermal Resistance (Junction to Ambient)	SOT-23	Non-Conductive Epoxy	θ_{JA}	260	°C / W
	SC-70-4 SC-70-5	Conductive Epoxy		331	
Thermal Resistance (Junction to Case)	SOT-23*	Non-Conductive Epoxy	θ_{JC}	81	
Internal Power Dissipation	SOT-23	Non-Conductive Epoxy	P_D	400	mW
	SC-70-4 SC-70-5	Conductive Epoxy		300	
Maximum Junction Temperature				150	°C
Solder Iron (10 Sec)**				350	°C

* Measure θ_{JC} on backside center of molding compound if IC has no tab.

** MIL-STD-202G 210F

AME8838
High PSRR, 150mA CMOS LDO
■ Electrical Specifications (Contd.)

$V_{OUT(nom)} > 2.0V$, $V_{IN} = V_{OUT(nom)} + 0.5V$; $V_{OUT} \leq 2V$, $V_{IN} = 2.5V$, $V_{EN} = V_{IN}$, $T_J = -40$ to $125^\circ C$, $C_{IN} = C_{OUT} = 1\mu F$ unless otherwise noted.

Parameter	Symbol	Test Condition	Min	Typ	Max	Units	
Input Voltage	V_{IN}		Note1		6	V	
Output Voltage Accuracy	$V_{OUT(nom)}$	$I_{OUT} = 1mA$, $T_A = 25^\circ C$	-1.5		1.5	%	
		$I_{OUT} = 1mA$, $T_J = -40$ to $125^\circ C$	-3		3		
Dropout Voltage (See Note 1)	$V_{DROPOUT}$	$I_{OUT} = 80mA$, $V_{OUT} \geq 3.0V$ $V_{OUT} = V_{OUT(nom)} - 2\%V_{OUT(nom)}$		80	170	mV	
		$I_{OUT} = 150mA$, $V_{OUT} \geq 3.0V$ $V_{OUT} = V_{OUT(nom)} - 2\%V_{OUT(nom)}$		120	240		
		$I_{OUT} = 80mA$, $2.5V \leq V_{OUT} < 3.0V$ $V_{OUT} = V_{OUT(nom)} - 2\%V_{OUT(nom)}$		90	200		
		$I_{OUT} = 150mA$, $2.5V \leq V_{OUT} < 3.0V$ $V_{OUT} = V_{OUT(nom)} - 2\%V_{OUT(nom)}$		135	270		
		$I_{OUT} = 80mA$, $2.0V < V_{OUT} < 2.5V$ $V_{OUT} = V_{OUT(nom)} - 2\%V_{OUT(nom)}$		120	250		
		$I_{OUT} = 150mA$, $2.0V < V_{OUT} < 2.5V$ $V_{OUT} = V_{OUT(nom)} - 2\%V_{OUT(nom)}$		180	360		
		$I_{OUT} = 150mA$, $V_{OUT} \leq 2.0V$, $V_{DROPOUT} = 2.5V - V_{OUT}$					
Current Limit	I_{LIM}	$V_{OUT} = 0.8 \times V_{OUT(nom)}$, $T_A = 25^\circ C$	200	350	500	mA	
Short Circuit Limit	I_{SC}	$V_{OUT} = 0V$, $T_A = 25^\circ C$		200			
Quiescent Current	I_Q	$T_A = 25^\circ C$, $V_{IN} = 6V$, $1mA < I_{OUT} < 150mA$		30	45	μA	
Line Regulation (See Note 2)	REG_{LINE}	$I_{OUT} = 1mA$, $V_{OUT} > 2.0V$ $V_{IN} = V_{OUT} + 0.5V$ to $V_{IN} = 6V$	$T_A = 25^\circ C$	-0.25	0.1	0.25	%V
			$T_J = -40$ to $125^\circ C$	-0.4		0.4	
		$I_{OUT} = 1mA$, $V_{OUT} \leq 2.0V$ $V_{IN} = 2.5V$ to $V_{IN} = 6V$	$T_A = 25^\circ C$	-0.4	0.2	0.4	
			$T_J = -40$ to $125^\circ C$	-0.6		0.6	
Load Regulation (See Note 3)	REG_{LOAD}	$I_{OUT} = 1$ to $150mA$	$V_{OUT} > 2.0V$ $V_{IN} = V_{OUT} + 0.5V$	-0.02	0.0025	0.02	%mA
			$V_{OUT} \leq 2.0V$ $V_{IN} = 2.5V$	-0.04	0.004	0.04	
Over Temperature Shutdown	OTS	$I_{OUT} = 0mA$		160		$^\circ C$	
Over Temperature Hysteresis	OTH	$I_{OUT} = 0mA$		40		$^\circ C$	
V_{OUT} Temperature Coefficient	TC			30		ppm/ $^\circ C$	
Power Supply Ripple Rejection	PSRR	$V_{IN} = 4.3V$, $V_{OUT} = 3.3V$, $C_{OUT} = 10\mu f$ $I_{OUT} = 100mA$, $f = 1kHz$		65		dB	



AME8838

High PSRR, 150mA CMOS LDO

■ Electrical Specifications

Parameter	Symbol	Test Condition	Min	Typ	Max	Units
Output Voltage Noise	e_N	$f = 10\text{Hz to } 100\text{kHz}, I_{OUT} = 10\text{mA}$		40		μVrms
Enable Input Threshold	V_{ENH}	$V_{OUT} \geq V_{OUT(min)}$	1.4		V_{IN}	V
	V_{ENL}	$V_{OUT} \leq 0.2\text{V}$	0		0.3	V
Enable Input Bias Current	I_{EN}	$V_{IN} = 6\text{V}, V_{EN} = 0\text{V or } 6\text{V}$		0.01	1	μA
Shutdown Supply Current	I_{SD}	$V_{IN} = 6\text{V}, V_{EN} = 0\text{V}$		0.5	1	μA
Shutdown Output Voltage	$V_{O,SD}$	$I_{OUT} = 1\text{mA}$			0.2	V

Note1: If $V_{OUT(nom)} > 2.0\text{V}$, $V_{IN(min)} = V_{OUT(nom)} + V_{DROPOUT}$. If $V_{OUT(nom)} \leq 2.0\text{V}$, $V_{IN(min)} = 2.5\text{V}$.

Note2: Line Regulation =
$$\frac{\frac{\Delta V_{out}}{\Delta V_{in}} \times 100\%}{V_{out}}$$

Note3: Load Regulation =
$$\frac{\frac{\Delta V_{out}}{V_{out}} \times 100\%}{\Delta I(mA)}$$

AME8838

High PSRR, 150mA CMOS LDO

■ Detailed Description

The AME8838 family of CMOS regulators contain a PMOS pass transistor, voltage reference, error amplifier, over-current protection, and thermal shutdown.

The P-channel pass transistor receives data from the error amplifier, over-current shutdown, and thermal protection circuits. During normal operation, the error amplifier compares the output voltage to a precision reference. Over-current and thermal shutdown circuits become active when the junction temperature exceeds 150°C, or the current exceeds 150mA. During thermal shutdown, the output voltage remains low. Normal operation is restored when the junction temperature drops below 130°C.

The AME8838 switches from voltage mode to current mode when the load exceeds the rated output current. This prevents over-stress.

■ External Capacitors

The AME8838 is stable with an output capacitor to ground of 1μF or larger. Ceramic capacitors have the lowest ESR, and will offer the best AC performance. Conversely, Aluminum Electrolytic capacitors exhibit the highest ESR, resulting in the poorest AC response.

A second capacitor is recommended between the input and ground to stabilize V_{IN} . The input capacitor should be at least 1μF to have a beneficial effect.

■ Enable

The Enable Pin is normally pull-high. When activated pulled low, the PMOS pass transistor shuts off, and all internal circuits are powered down. In this state, the standby current is less than 1μA. This pin can't be floating.

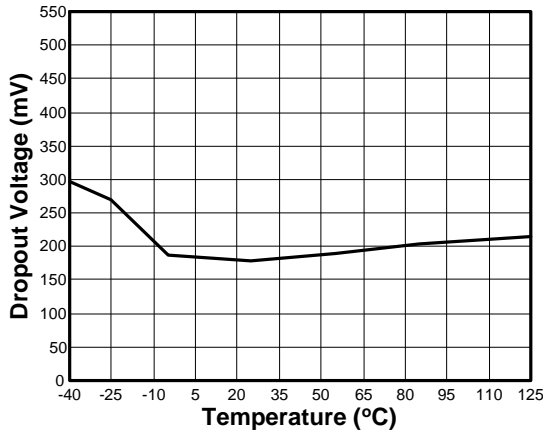
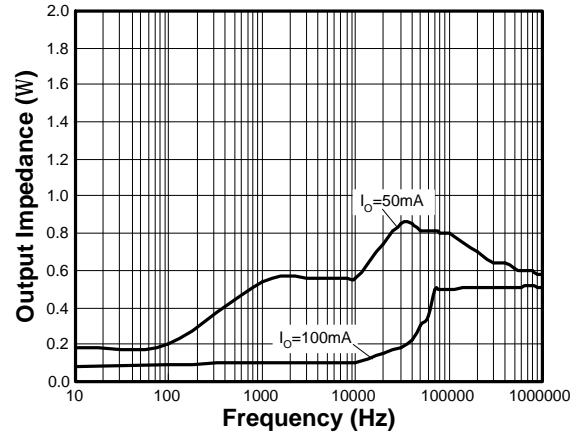
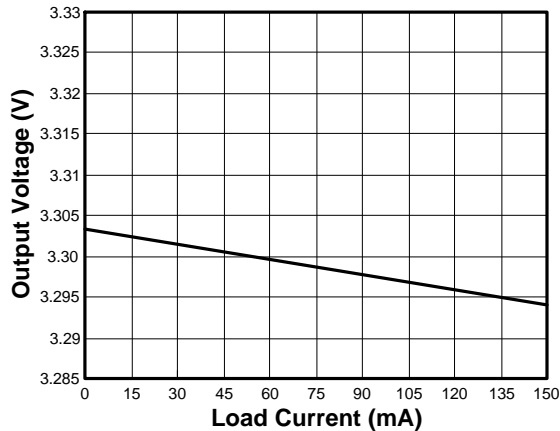
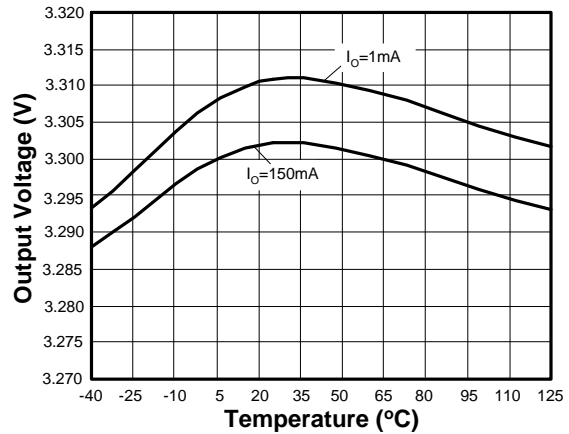
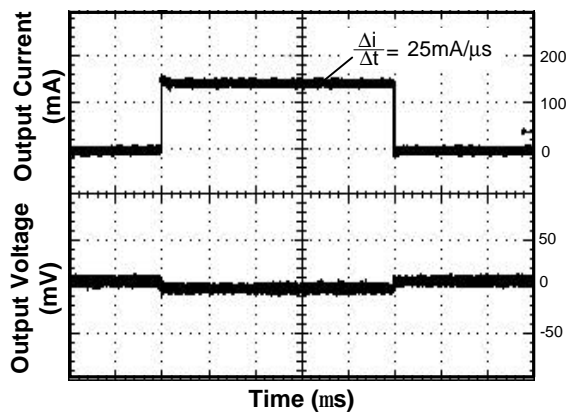
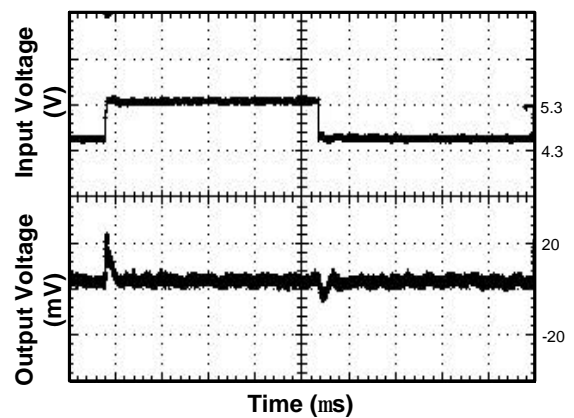
AME8838
High PSRR, 150mA CMOS LDO
Dropout Voltage vs Temperature

Output Impedance vs Frequency

Output Voltage vs Load Current

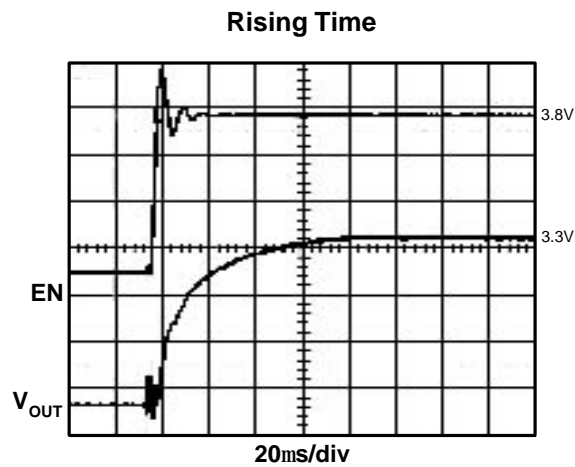
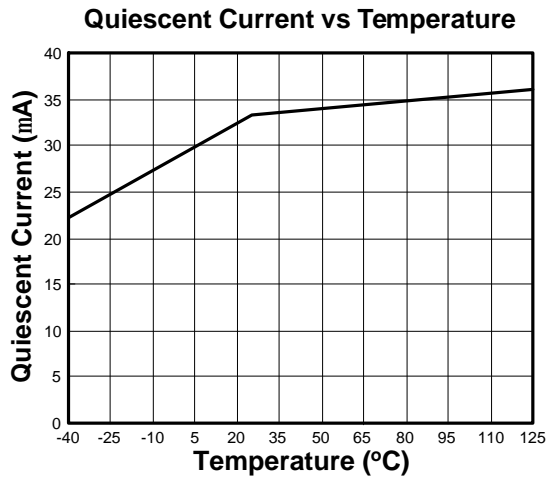
Output Voltage vs Temperature

Load Transient Response

Line Transient Response

AME8838

High PSRR, 150mA CMOS LDO





AME8838

High PSRR, 150mA CMOS LDO

■ Date Code Rule

For SC-70 Package Only

Marking			Date Code	Year
A	A	A	W	xxx0
A	A	A	<u>W</u>	xxx1
A	A	<u>A</u>	W	xxx2
A	A	<u>A</u>	<u>W</u>	xxx3
A	<u>A</u>	A	W	xxx4
A	<u>A</u>	A	<u>W</u>	xxx5
A	<u>A</u>	<u>A</u>	W	xxx6
A	<u>A</u>	<u>A</u>	<u>W</u>	xxx7
<u>A</u>	A	A	W	xxx8
<u>A</u>	A	A	<u>W</u>	xxx9

w: Work Week Code					
A:	01&02	K:	21&22	U:	41&42
B:	03&04	L:	23&24	V:	43&44
C:	05&06	M:	25&26	W:	45&46
D:	07&08	N:	27&28	X:	47&48
E:	09&10	O:	29&30	Y:	49&50
F:	11&12	P:	31&32	Z:	51&52
G:	13&14	Q:	33&34		
H:	15&16	R:	35&36		
I:	17&18	S:	37&38		
J:	19&20	T:	39&40		

For SOT-23 Package

Marking			Date Code		Year
A	A	A	W	W	xxx0
A	A	A	W	<u>W</u>	xxx1
A	A	A	<u>W</u>	W	xxx2
A	A	A	<u>W</u>	<u>W</u>	xxx3
A	A	<u>A</u>	W	W	xxx4
A	A	<u>A</u>	W	<u>W</u>	xxx5
A	A	<u>A</u>	<u>W</u>	W	xxx6
A	A	<u>A</u>	<u>W</u>	<u>W</u>	xxx7
A	<u>A</u>	A	W	W	xxx8
A	<u>A</u>	A	W	<u>W</u>	xxx9

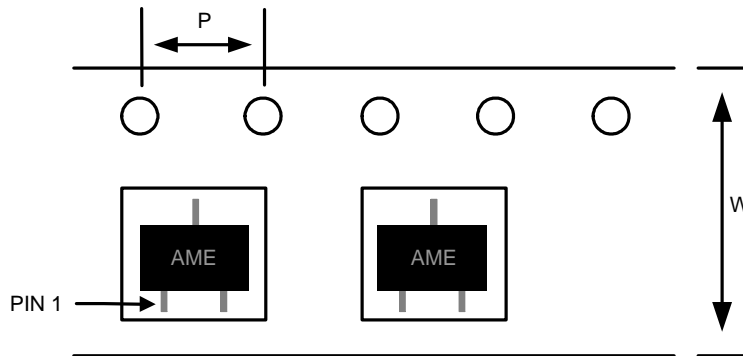
AME8838
High PSRR, 150mA CMOS LDO
■ Tape and Reel Dimension
SOT-23

Carrier Tape, Number of Components Per Reel and Reel Size

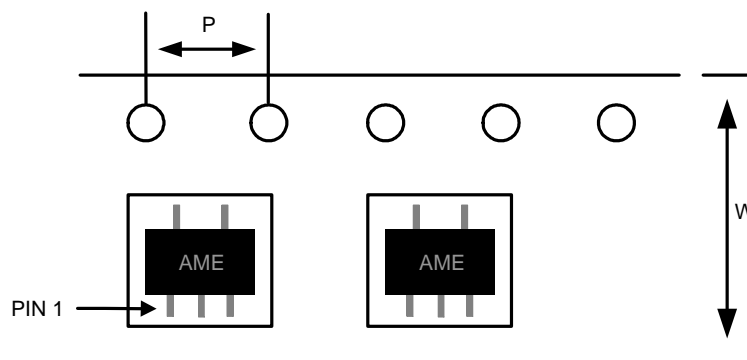
Package	Carrier Width (W)	Pitch (P)	Part Per Full Reel	Reel Size
SOT-23	8.0±0.1 mm	4.0±0.1 mm	3000pcs	180±1 mm

SC-70-5

Carrier Tape, Number of Components Per Reel and Reel Size

Package	Carrier Width (W)	Pitch (P)	Part Per Full Reel	Reel Size
SC-70-5	8.0±0.1 mm	4.0±0.1 mm	3000pcs	180±1 mm



AME8838

High PSRR, 150mA CMOS LDO

■ Tape and Reel Dimension

SC-70-4

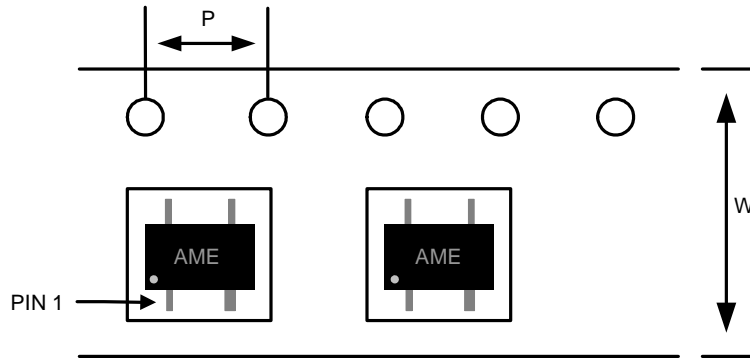

Carrier Tape, Number of Components Per Reel and Reel Size

Package	Carrier Width (W)	Pitch (P)	Part Per Full Reel	Reel Size
SC-70-4	8.0±0.1 mm	4.0±0.1 mm	3000pcs	180±1 mm

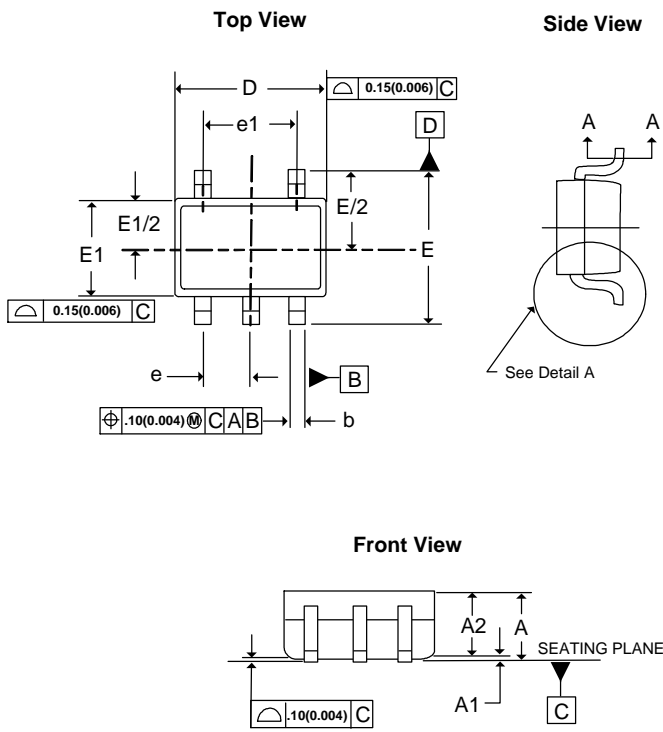
AME8838
High PSRR, 150mA CMOS LDO
■ Package Dimension
SC-70-5

SYMBOLS	MILLIMETERS		INCHES	
	MIN	MAX	MIN	MAX
A	0.80	1.10	0.031	0.043
A1	0.00	0.10	0.000	0.004
A2	0.80	1.00	0.031	0.040
b	0.15	0.30	0.006	0.012
b1	0.15	0.25	0.006	0.010
c	0.08	0.25	0.003	0.010
c1	0.08	0.20	0.003	0.008
D	1.90	2.15	0.074	0.084
E	2.00	2.20	0.078	0.086
E1	1.15	1.35	0.045	0.055
e	0.65BSC		0.0255BSC	
e1	1.30BSC		0.0512BSC	
L	0.26	0.46	0.010	0.018
q1	0°	8°	0°	8°
q2	4°	10°	4°	10°

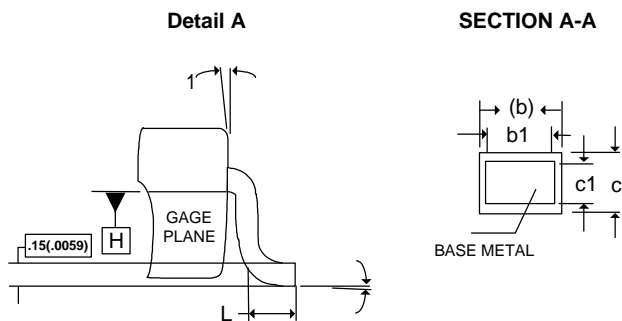

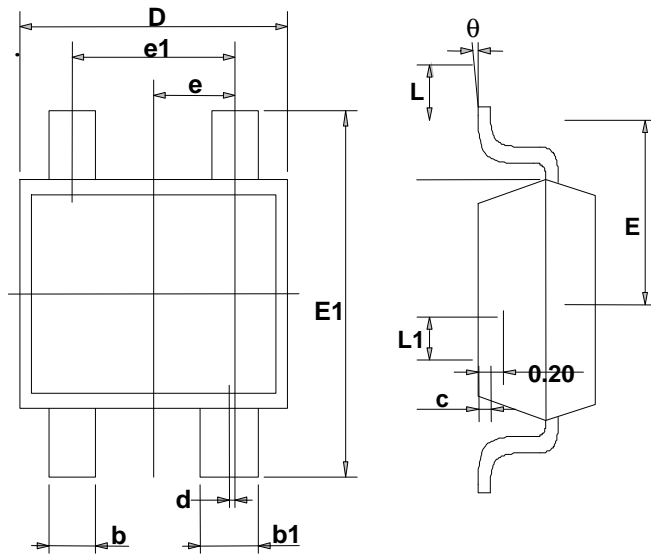
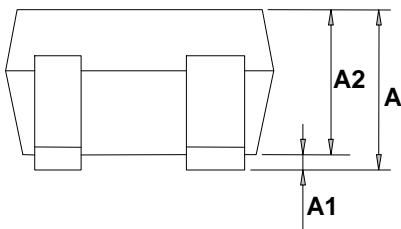
AME8838
High PSRR, 150mA CMOS LDO
■ Package Dimension
SC-70-4

TOP VIEW
SIDE VIEW

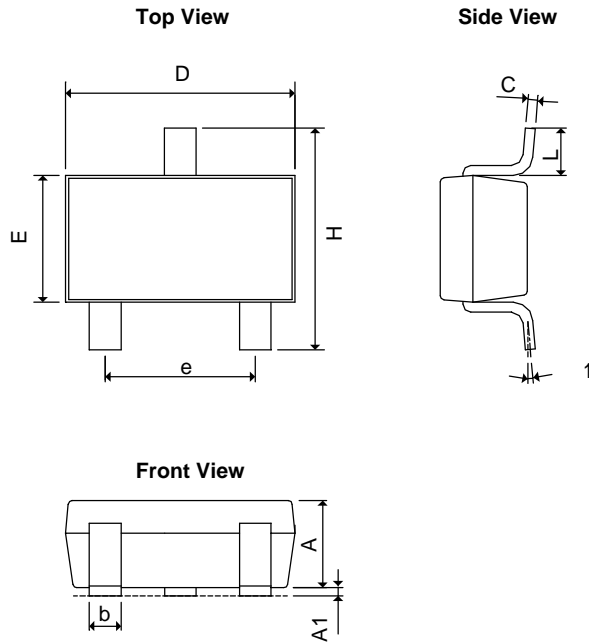
FRONT VIEW

SYMBOLS	MILLIMETERS		INCHES	
	MIN	MAX	MIN	MAX
A	0.900	1.100	0.035	0.043
A1	0.000	0.100	0.000	0.004
A2	0.900	1.000	0.035	0.039
b	0.250	0.400	0.010	0.016
b1	0.350	0.500	0.014	0.020
c	0.080	0.150	0.003	0.006
d	0.050 TYP		0.002 TYP	
D	2.000	2.200	0.079	0.087
E	1.150	1.350	0.045	0.053
E1	2.150	2.450	0.085	0.096
e	0.650 TYP		0.026 TYP	
e1	1.200	1.400	0.047	0.055
L	0.525 REF		0.021 REF	
L1	0.260	0.460	0.010	0.018
q	0°	8°	0°	8°

AME8838
High PSRR, 150mA CMOS LDO
■ Package Dimension
SOT-23

SYMBOLS	MILLIMETERS		INCHES	
	MIN	MAX	MIN	MAX
A	1.00	1.40	0.0394	0.0551
A₁	0.00	0.15	0.0000	0.0059
b	0.35	0.50	0.0138	0.0197
C	0.09	0.25	0.0035	0.0098
D	2.70	3.10	0.1063	0.1220
E	1.40	1.80	0.0551	0.0709
e	1.90 BSC		0.0748 BSC	
H	2.40	3.00	0.09449	0.11811
L	0.35BSC		0.0138BSC	
q1	0°	10°	0°	10°



www.ame.com.tw
E-Mail: sales@ame.com.tw

Life Support Policy:

These products of AME, Inc. are not authorized for use as critical components in life-support devices or systems, without the express written approval of the president of AME, Inc.

AME, Inc. reserves the right to make changes in the circuitry and specifications of its devices and advises its customers to obtain the latest version of relevant information.

© AME, Inc. , September 2007

Document: 1003-DS8838-E.04

Corporate Headquarter
AME, Inc.

2F, 302 Rui-Guang Road, Nei-Hu District
Taipei 114, Taiwan.
Tel: 886 2 2627-8687
Fax: 886 2 2659-2989

U.S.A.(Subsidiary)
Analog Microelectronics, Inc.

3100 De La Cruz Blvd., Suite 201
Santa Clara, CA. 95054-2438
Tel : (408) 988-2388
Fax: (408) 988-2489