

CMOS OR GATES

4071B - Quad 2-Input OR
4072B - Dual 4-Input OR
4075B - Triple 3-Input OR

FEATURES

- ◆ Buffered Outputs
- ◆ Diode Protection on all Inputs
- ◆ Fully "B"-Series Compatible

TRUTH TABLE

Inputs	Output
00...0	0
All other combinations	1

FUNCTION DIAGRAMS

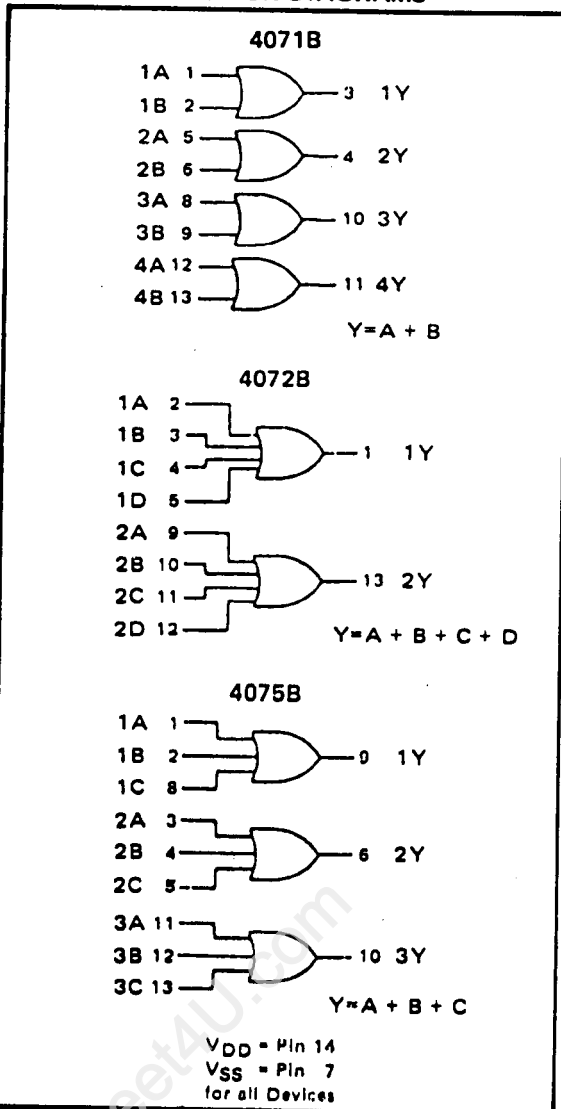

CONNECTION DIAGRAMS (all packages)

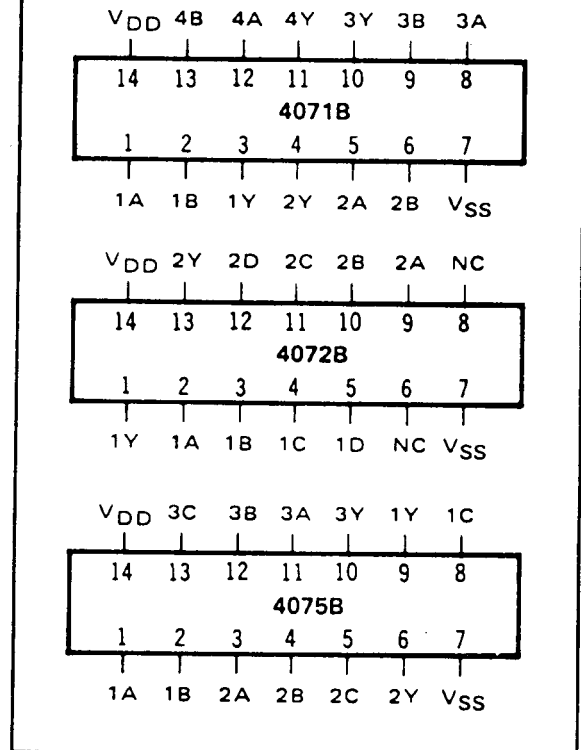

RECOMMENDED OPERATING CONDITIONS

For maximum reliability:

DC Supply Voltage $V_{DD} - V_{SS}$ 3 to 15 Vdc

Operating Temperature T_A

C -55 to +125 °C
E -40 to +85 °C

ELECTRICAL CHARACTERISTICS

STATIC CHARACTERISTICS¹

PARAMETER	V _{DD} (Vdc)	CONDITIONS	T _{LOW} ²		+25°C			T _{HIGH} ²		Units
			Min.	Max.	Min.	Typ.	Max.	Min.	Max.	
QUIESCENT DEVICE CURRENT	I _{DD}	V _{IN} =V _{SS} or V _{DD} All valid input combinations	-	0.05	-	0.0005	0.05	-	1.5	μAdc
			-	0.10	-	0.001	0.10	-	3.0	
			-	0.20	-	0.002	0.20	-	6.0	

NOTES: ¹ Remaining Static Electrical Characteristics are listed under "4000B Series Family Specifications".

² T_{LOW} = -55°C for C
 = -40°C for E
 T_{HIGH} = +125°C for C
 = + 85°C for E

DYNAMIC CHARACTERISTICS (C_L = 50pF, T_A = 25°C)

PARAMETER		V _{DD} (Vdc)	Min.	Typ.	Max.	Units
PROPAGATION DELAY TIME	t _{PLH} , t _{PHL}	5	-	100	200	ns
		10	-	50	100	
		15	-	40	80	
OUTPUT TRANSITION TIME	t _{TLH} , t _{THL}	5	-	90	180	ns
		10	-	45	90	
		15	-	40	80	

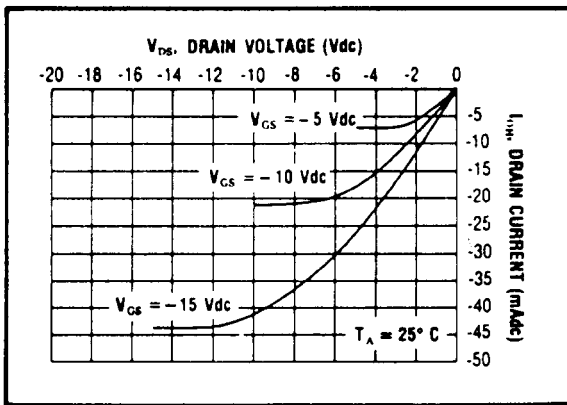

Typical P-Channel Source Current Characteristics
LOGIC DIAGRAMS

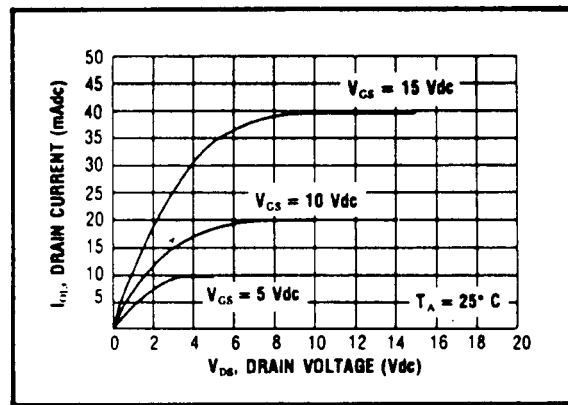

Typical N-Channel Sink Current Characteristics
SCHEMATIC DIAGRAM 4072B (1 of 2 gates)

