



# Chunghwa Picture Tubes, Ltd.

## Product Specification

To :

Date : 2010/03/04

**TFT LCD**  
**CLAA070NC0BCT**

ACCEPTED BY :

APPROVED BY	CHECKED BY	PREPARED BY
Ronald Huang	Roger Liu	Carol Shen

Prepared by :

TFT-LCD Product Planning Management Division

**CHUNGHWA PICTUER TUBES, LTD.**

1127 Hopin Rd., Padeh, Taoyuan, Taiwan 334, R.O.C.  
TEL: +886-3-3675151 FAX: +886-3-377-3003

Doc.No:	CLAA070NC0BCT-V1-20100304	Issue Date:	20100304
---------	---------------------------	-------------	----------

**REVISION STATUS**

Revision Notice	Description	Page	Rev. Date
0.0	Temtative revision	--	2008/11/6

## CONTENTS

<b>1. OVERVIEW</b> .....	<b>4</b>
<b>2. ABSOLUTE MAXIMUM RATINGS</b> .....	<b>5</b>
<b>3. ELECTRICAL CHARACTERISTICS</b> .....	<b>6</b>
3.1 TFT LCD .....	6
3.2 TFT-LCD Current Consumption.....	7
3.3 Power 、 signal sequence .....	7
<b>4. INTERFACE CONNECTION</b> .....	<b>8</b>
<b>5. INPUT SIGNAL(DE ONLY MODE)</b> .....	<b>10</b>
5.1 Timing Specification.....	10
5.2 Timing sequence(Timing chart) .....	10
5.3 LVDS Input Data mapping .....	11
<b>6. CHARACTERISTIC OF TOUCH PANEL</b> .....	<b>12</b>
6.1 Basis characteristic .....	12
6.2 Design guideline for Touch-Panel .....	12
6.3 Circuit Diagram .....	12
<b>7. BLOCK DIAGRAM</b> .....	<b>13</b>
<b>8. MECHANICAL DIMENSION</b> .....	<b>14</b>
8.1 Front Side .....	14
8.2 Rear Side.....	15
<b>9. OPTICAL CHARACTERISTICS</b> .....	<b>16</b>
<b>10. RELIABILITY TEST</b> .....	<b>18</b>
10.1. Temperature and humidity .....	18
10.2. Shock and Vibration .....	18
10.3 ESD .....	18
10.4 Judgment standard .....	18

## 1. OVERVIEW

CLAA070NC0BCT is 7" color TFT-LCD(Thin Film Transistor Liquid Crystal Display)module composed of LCD panel,driver ICs,control circuit,and LED backlight.

The 7.0"screen produces a high resolution image that is composed of 1024×600 pixel elements in a stripe arrangement.Display 262K colors by 6 Bit R.G.B signal input.

General specifications are summarized in the following table :

ITEM	SPECIFICATION
Display Area (mm)	153.6(H)×90(V)
Number of Pixels	1024(H)×3(RGB)×600(V)
Pixel Pitch (mm)	0.15(H)×0.15(V)
Color Pixel Arrangement	RGB vertical stripe
Display Mode	Normally white
Number of colors	262K
Viewing Direction	6 o'clock
Response Time (Tr+Tf)	20ms(typ.)
Brightness(cd/m <sup>2</sup> )	300nit(typ)
Viewing Angle(BL on,CR ≥ 10)	140 degree(H) , 110degree(V)
Electrical Interface(data)	LVDS
Power consumption	2.83W (TYP)
Outline Dimension(in mm)	165(W)×102(H)×6(D)
Weight(g)	140g(TYP)
BL unit	LED
Surface Treatment	Glare , Hardness:3H
Touch Panel Type	4 wire resistive

## 2. ABSOLUTE MAXIMUM RATINGS

ITEM	SYMBOL	MIN.	MAX.	UNIT	NOTE
LCD input Voltage	V <sub>cc</sub>	-0.3	4.0	V	
LED input Voltage	V <sub>LED</sub>	-0.3	6	V	
Signal Input Voltage	RxIN0+ ~ RxIN2+ RxIN0- ~ RxIN2- Rx CLK IN +/-	-0.3	V <sub>cc</sub> +0.3	V	
Static Electricity	VESD <sub>c</sub>	-200	+200		【Note2】
	VESD <sub>m</sub>	-15K	+15K	V	
ICC Rush Current	IRUSH	--	1	A	【Note3】
Operation Temperature	T <sub>op</sub>	-20	70	°C	【Note1】
Storage Temperature	T <sub>stg</sub>	-30	80	°C	【Note1】

NOTE :

【Note1】 If users use the product out off the environment operation range (temperature and humidity) ,it will concern for visual quality.

【Note2】 Test Condition: IEC 61000-4-2 ,  
VESD<sub>c</sub> : Contact discharge to input connector  
VESD<sub>m</sub> : Contact discharge to module

【Note3】 Control signal:High(+3.3V)→Low(GND)  
Supply Voltage of rising time should be from R3 and C2 tune to 550 us.

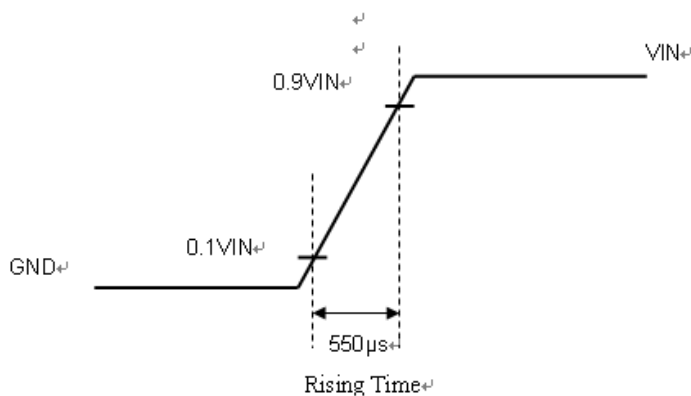
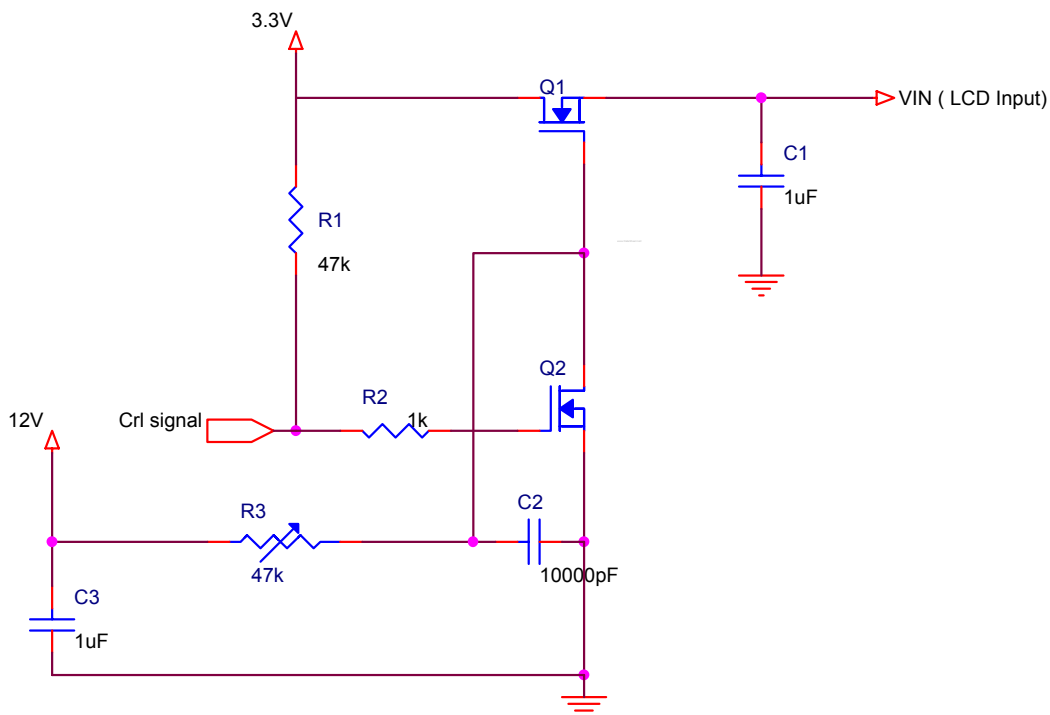

### 3. ELECTRICAL CHARACTERISTICS

#### 3.1 TFT LCD

Ta=25°C

ITEM	SYMBOL	MIN.	TYP.	MAX.	UNIT	NOTE
Power Supply Voltage For LCD	VCC	3.0	3.3	3.6	V	
Power Supply Voltage For LED	VLED	4.5	5.0	5.5		
Logic Input Voltage (LVDS:IN+,IN-)	VCM	1.08	1.2	1.32	V	[Note1]
	VID	250	350	450	mV	[Note1]
	VTH	--	--	100	mV	[Note1]
	VTL	-100	--	--	mV	[Note1] When VCM=+1.2V
ADJ Input Voltage	VIH	3.0		3.3	V	
	VIL	GND		0.3	V	

NOTE :

[Note1] LVDS signal

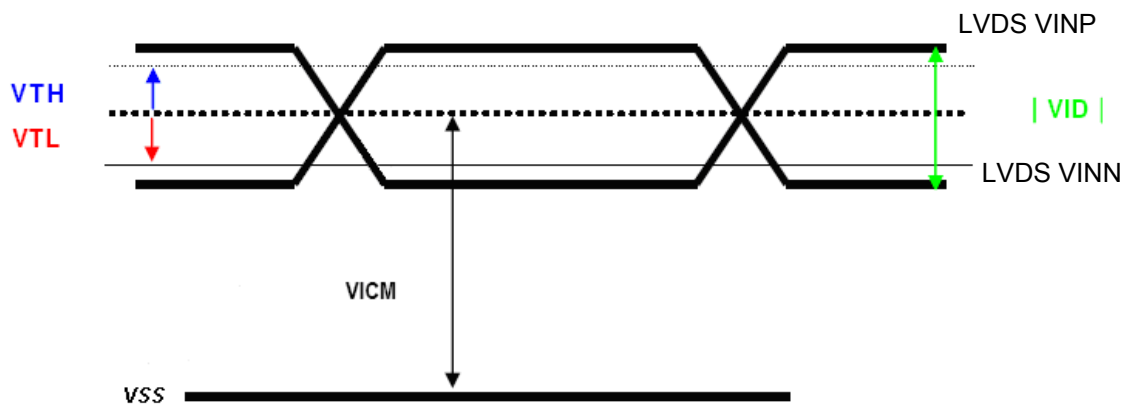

3.2 TFT-LCD Current Consumption

ITEM	SYMBOL	MIN.	TYP.	MAX.	UNIT	NOTE
LCD Power Current	ICC	--	250	300	mA	【Note1】
LED Power Current	IDD		400	450	mA	【Note2】

【Note1】 Typical: Under 64 gray pattern  
 Maximum: Under black pattern



(a)64 Gray Pattern



(b)Black Pattern

【Note2】 Typical: When VDD is 5V  
 Maximum: When VDD is 4.5V

3.3 Power 、 signal sequence

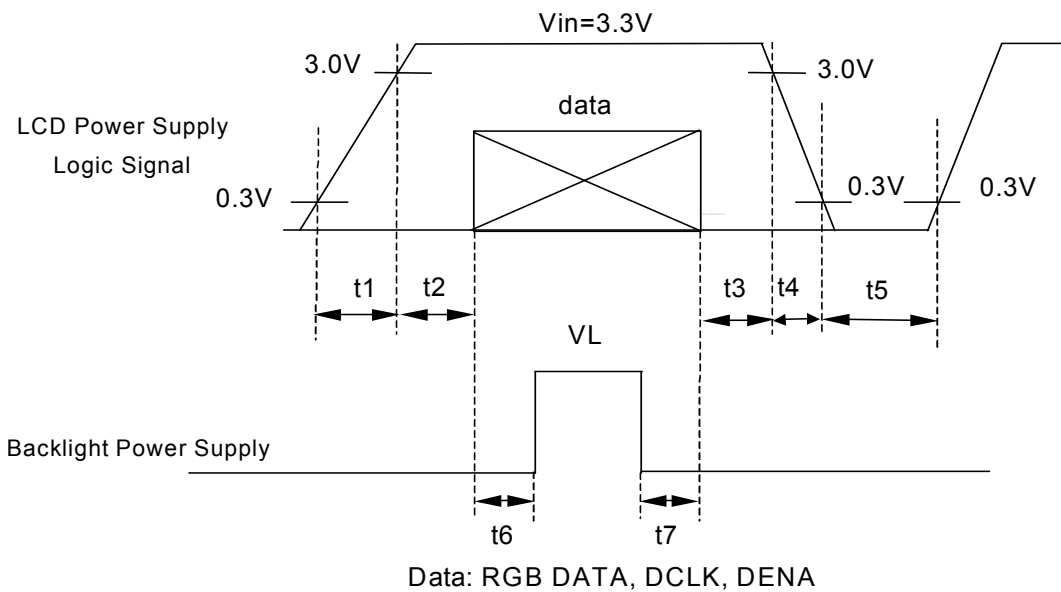

- 0.5 <math>t\_1 \le 10\text{ms}</math>      200ms <math>\le t\_5</math>
- 0 <math>t\_2 \le 50\text{ms}</math>      200ms <math>\le t\_6</math>
- 0 <math>t\_3 \le 50\text{ms}</math>      200ms <math>\le t\_7</math>
- 0 <math>t\_4 \le 10\text{ms}</math>

**4. INTERFACE CONNECTION**

CN1 : STARCONN P/N (089N30-00R00-G2)

Pin NO.	SYMBOL	DESCRIPTION
1	AVSS	Power Ground
2	VCC	Power Supply for Digital circuit
3	VCC	Power Supply for Digital circuit
4	V_EDID	Power Supply for EDID circuit
5	ADJ	Adjust for LED brightness
6	CLK_EDID	EDID clock inputs
7	DATA_EDID	EDID data inputs
8	RXIN0-	Negative LVDS differential data inputs
9	RXIN0+	Positive LVDS differential data inputs
10	AVSS	Power Ground
11	RXIN1-	Negative LVDS differential data inputs
12	RXIN1+	Positive LVDS differential data inputs
13	AVSS	Power Ground
14	RXIN2-	Negative LVDS differential data inputs
15	RXIN2+	Positive LVDS differential data inputs
16	AVSS	Power Ground
17	RXCLK-	Negative LVDS differential clock inputs
18	RXCLK+	Positive LVDS differential clock inputs
19	AVSS	Power Ground
20	NC	NC
21	NC	NC
22	LR	Left / Right Display Control
23	UD	Up / Down Display Control
24	VLED	Power Supply for LED
25	VLED	Power Supply for LED
26	VLED	Power Supply for LED
27	YD	Touch Panel control pin
28	XL	Touch Panel control pin
29	YU	Touch Panel control pin
30	XR	Touch Panel control pin



## NOTE :

- 1) NC Pin must be retain, this pin can't contact GND or other signal.
- 2) GND Pin must ground contact , can not be floating.
- 3) ADJ adjust brightness to control Pin , Pulse duty the more big the more bright



- 4) ADJ signal=0~3.3V , operation frequency :  $25 \pm 5\text{KHz}$

$$F=25\text{KHz} \pm 5\text{KHz} , T=0.05\text{ms}$$

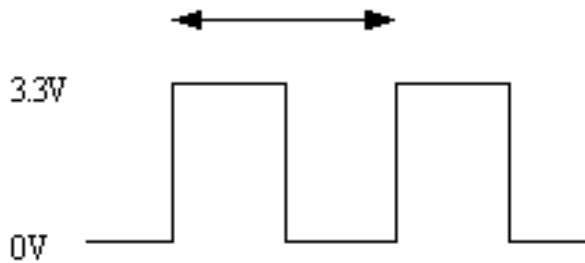

- 5) U/D and L/R are controled function

L/R	U/D	FUNCTION
1	0	Normally display
0	0	Left and Right opposite
1	1	Up and Down opposite
0	1	Left and Right opposite , Up and Down opposite

### 5. INPUT SIGNAL(DE ONLY MODE)

#### 5.1 Timing Specification

ITEM			SYMBOL	MIN.	TYP.	MAX.	UNIT	
LVDS input signal sequence	CLK Frequency		fCLKin	39	45	52	MHz	
LCD input signal sequence (Input LVDS Transmitter)	DENA	Horizontal	Horizontal total Time	$t_H$	1150	1200	1250	tCLK
			Horizontal effective Time	$t_{HA}$	1024			tCLK
			Horizontal Blank Time	$t_{HB}$	126	176	226	tCLK
	Vertical	Frame	fV	55	60	65	Hz	
		Vertical total Time	$t_V$	610	625	640	t <sub>H</sub>	
		Vertical effective Time	$t_{VA}$	600			t <sub>H</sub>	
		Vertical Blank Time	$t_{VB}$	10	25	40	t <sub>H</sub>	

#### 5.2 Timing sequence(Timing chart)

##### 5.2.1 Horizontal Timing Sequence

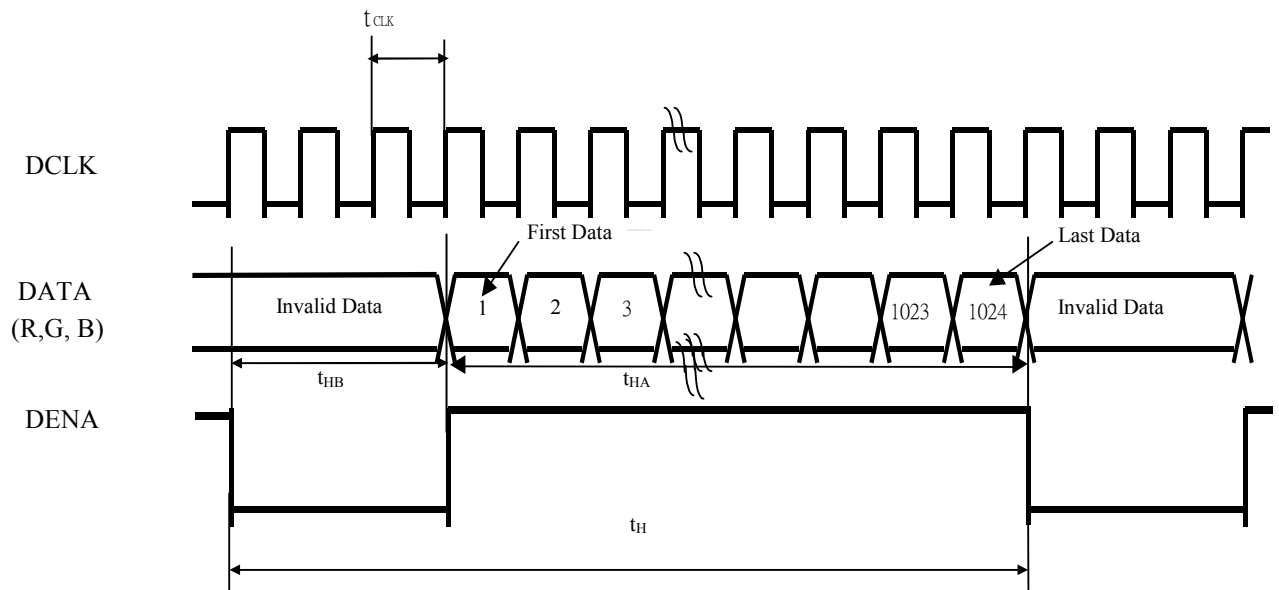

##### 5.2.2 Vertical Timing Sequence

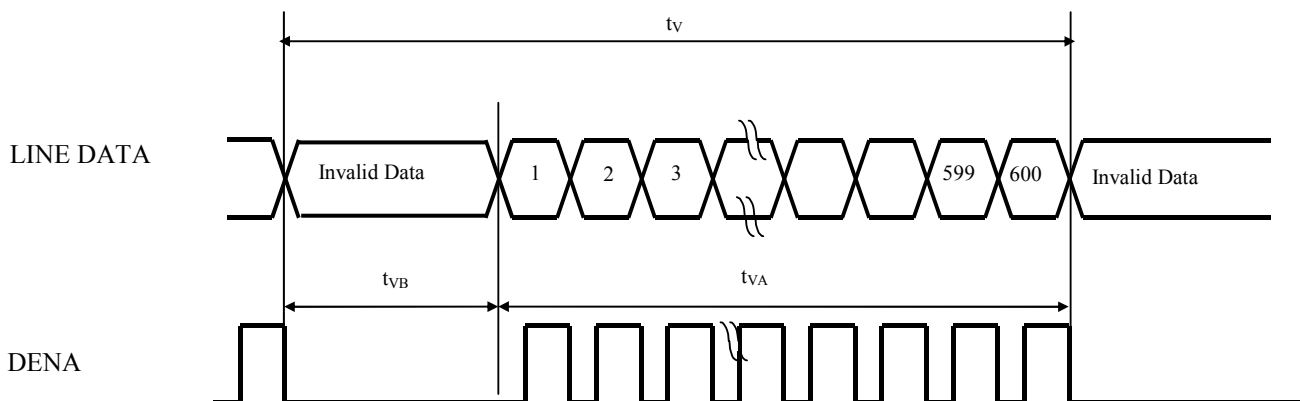

5.3 LVDS Input Data mapping

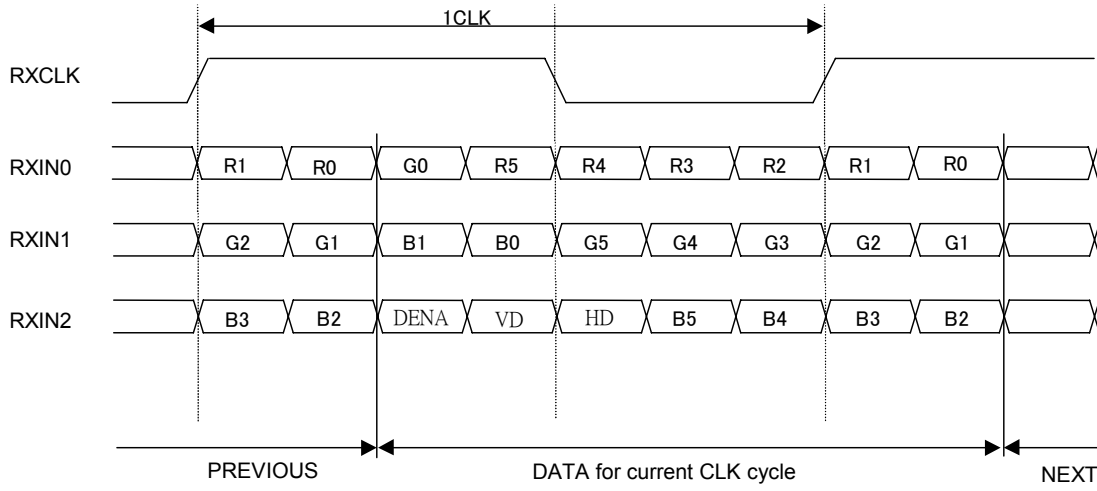

## 6. CHARACTERISTIC OF TOUCH PANEL

### 6.1 Basis characteristic

ITEM	STANDARD	NOTE
Operating Voltage	5V(Typ) / 7V(Max)	DC
Surface Treatment	Glare · Hardness : 3H	pencil hardness, 45° / 4.9Nt
Activation Force	Max. 80gf	Individual with stylus pen (R 0.8mm) or finger (R 8.0mm) · Testing area : AA inside 2mm
Interface Type	4 Wire Resistive	
Resistance Between Terminals	X(Film side) : 200~1200Ω Y(Glass side) : 200~900Ω	At the connector
Linearity	X(Film side) : ≤ 1.5% Y(Glass side) : ≤ 1.5%	Testing interval is 5mm with load 120g · Testing area : AA inside 2mm
Insulation Resistance	Min. 20MΩ	At DC 25V
Another	1. Two Layer TSP (film : Nitton Denko) 2. Puffiness < 0.4mm	

### 6.2 Design guideline for Touch-Panel

- (a) The housing cushion on touch-panel must be set at outside of T.P's view-area .
- (b) The cushion material must be elastic material.
- (c) The housing must avoid to touch the T.P
- (d) To combine, the housing should not be stuck on T.P.
- (e) Example of housing design :

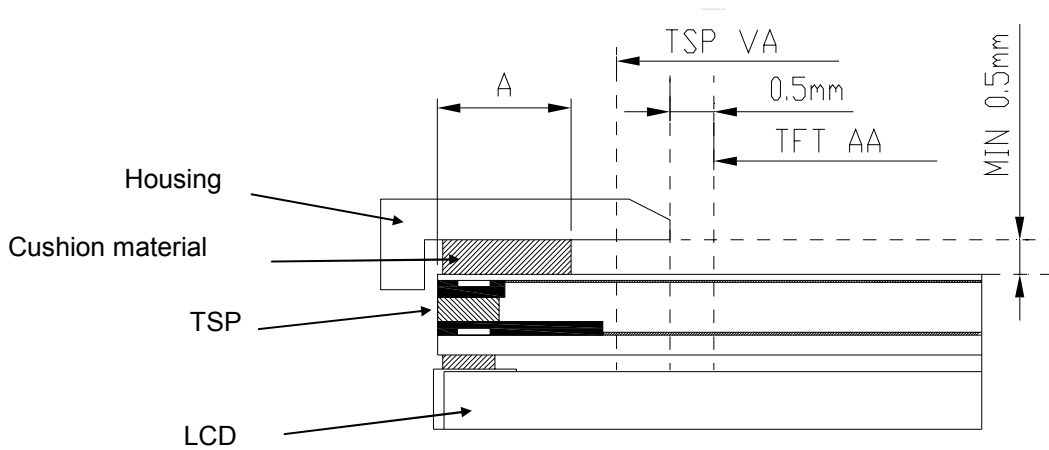

### 6.3 Circuit Diagram

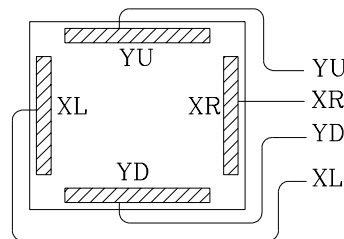

Circuit Diagram

### 7. BLOCK DIAGRAM

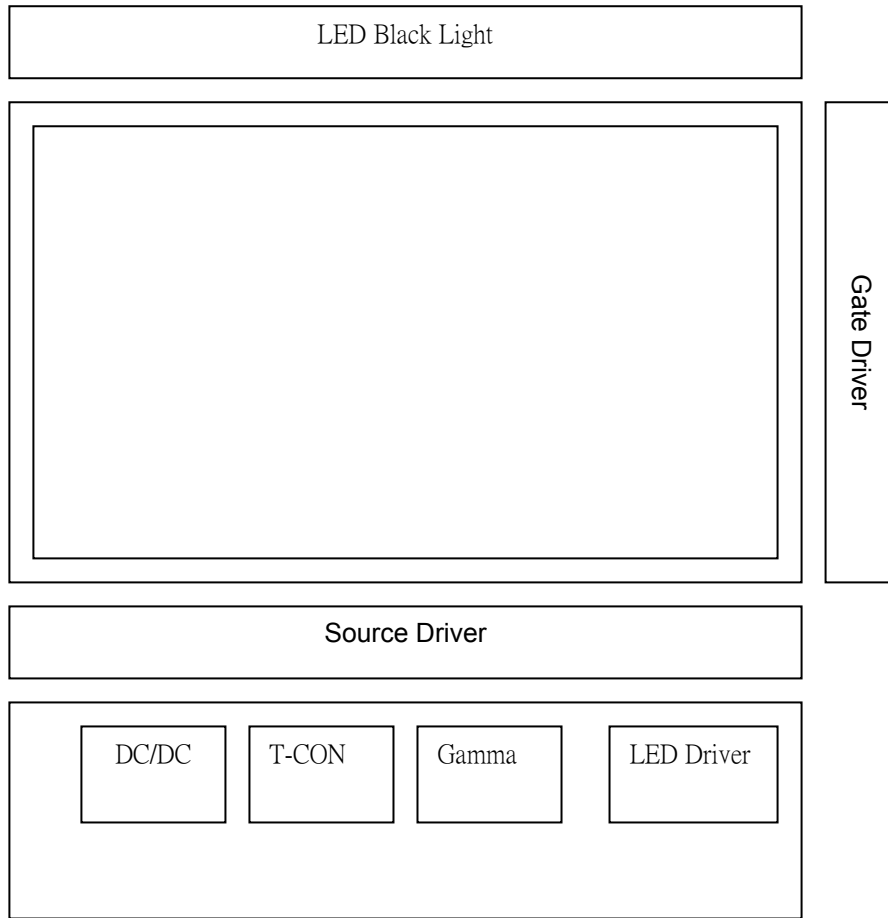

### 8. MECHANICAL DIMENSION

#### 8.1 Front Side

[Unit : mm]

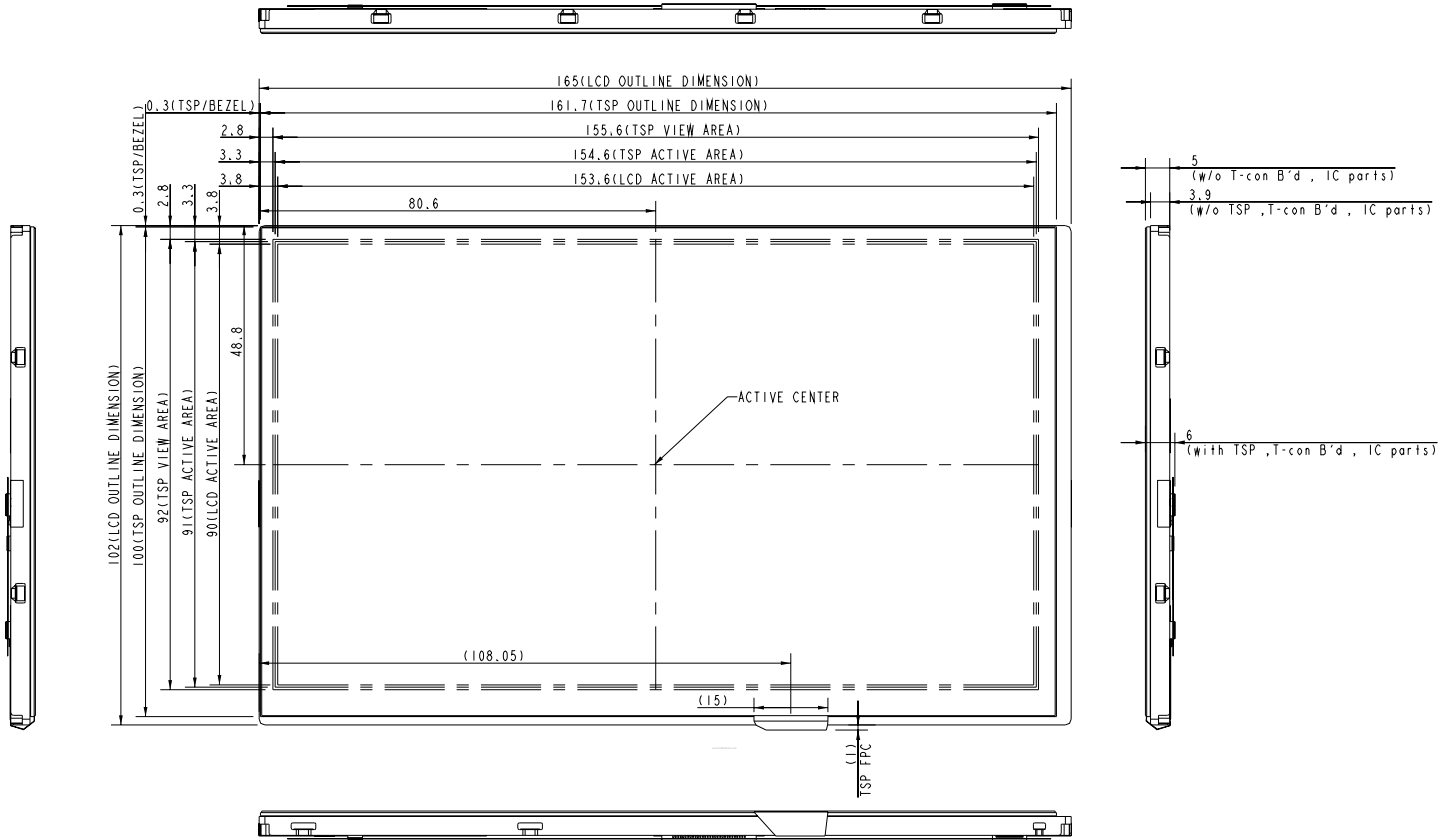

NOTE: General tolerance : ±0.3mm

## 8.2 Rear Side

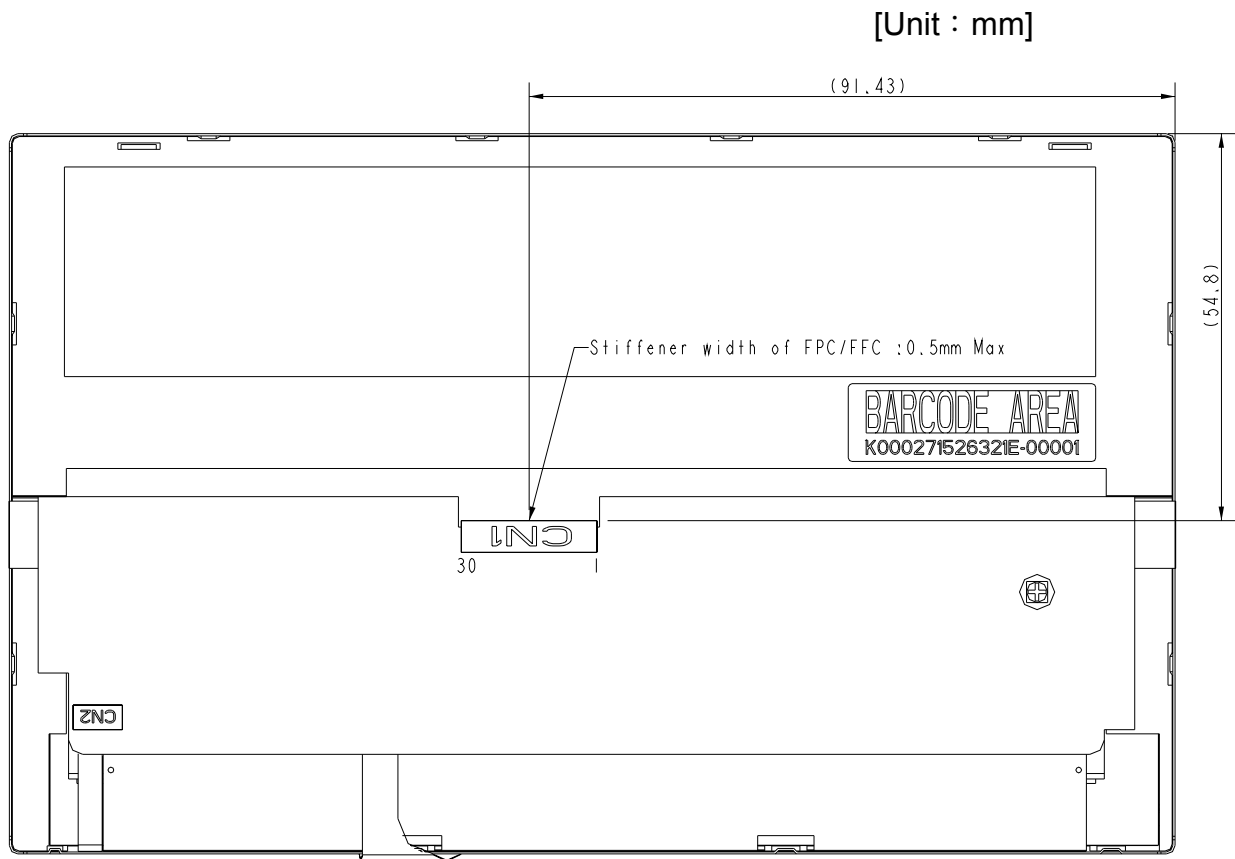

## NOTE :

1. General tolerance :  $\pm 0.3\text{mm}$
2. LCD connector CN1(30pin) : STARCONN , P/N : 089N30-000R00-G2
3. We suggest the mounting structure must has a reserved space for the TSP FPC tail and never touch or squeeze the TSP FPC by case or another components preventing FPC from peeling off. The space is recommended at least 1mm.

## 9. OPTICAL CHARACTERISTICS

ITEM	SYMBOL	CONDITION	MIN.	TYP.	MAX.	UNIT	NOTE	
Constrast Ratio	CR	Point-5	---	400	--	--	*1)*2)*3)	
Luminance*)	Lw	Point-5	240	300	--	cd/m <sup>2</sup>	*1)*3)	
Luminance Uniformity	$\Delta L$		70	80	--	%	*1)*3)	
Response Time (White - Black)	Tr+ Tf	Point-5	--	20	30	ms	*1)*3)*5)	
Viewing Angle	Horizontal	$\psi$	CR $\geq$ 10 Point-5	120	140	--	°	*1)*2)*4)
	Vertical	$\theta$		100	120	--	°	*1)*2)*4)
Color Coordinate	White	Wx Wy	Point-5	0.273 0.289	0.313 0.329	0.353 0.369	*1)*3)	*1)*3)
	Red	Rx Ry		0.546 0.309	0.576 0.339	0.606 0.369		
	Green	Gx Gy		0.317 0.543	0.347 0.573	0.377 0.603		
	Blue	Bx By		0.125 0.091	0.155 0.121	0.185 0.151		

NOTE :

\*1)Measure condition : 25°C $\pm$ 2°C , 60 $\pm$ 10%RH , under10 Lux in the dark room.BM-5A (TOPCON) , viewing angle2° , VCC=3.3V , Vadj=3.3V Duty 100%. test the panel after turning on10 minute ago

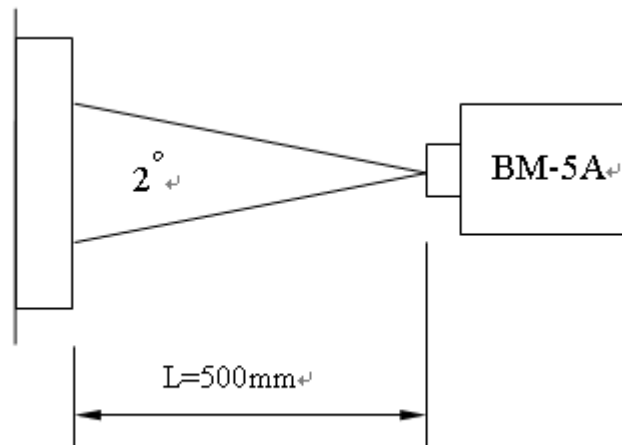

\*2) Definition of contrast ratio :

Contrast Ratio (CR)= (White) Luminance of ON  $\div$  (Black) Luminance of OFF

\*3) Definition of luminance :

Measure white luminance on the point 5 as figure8-1

Definition of Luminance Uniformity:

Measure white luminance on the point1~9as figure8-1

$$\Delta L = [L(\text{MIN})/L(\text{MAX})] \times 100$$



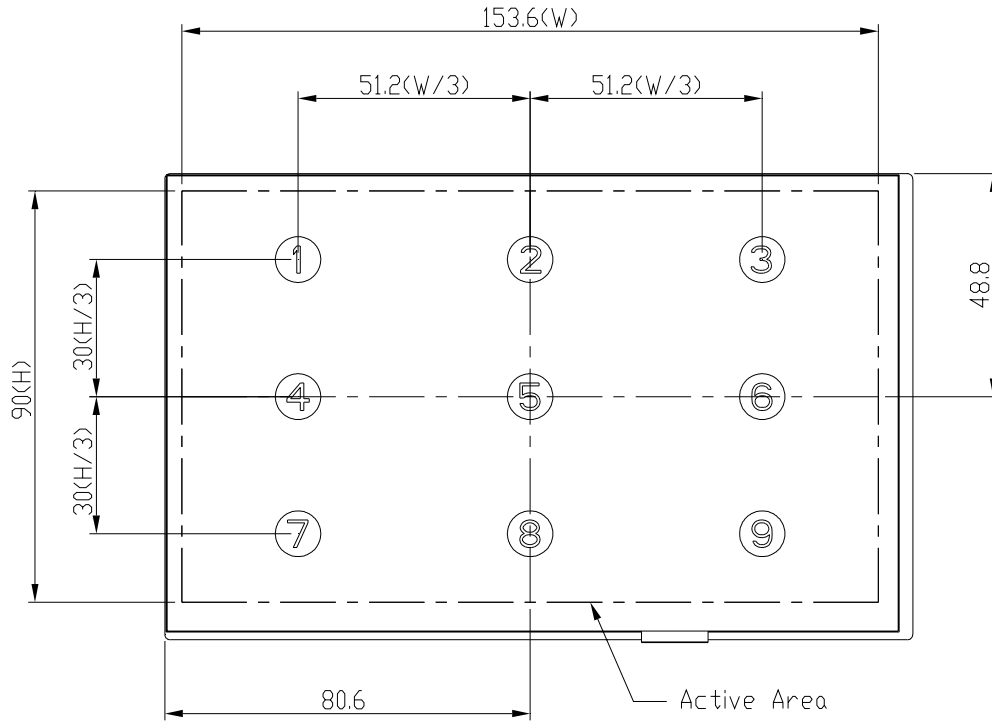

Fig8-1 Measuring point

\*4) Definition of Viewing Angle( $\theta, \psi$ ), refer to Fig8-2 as below :

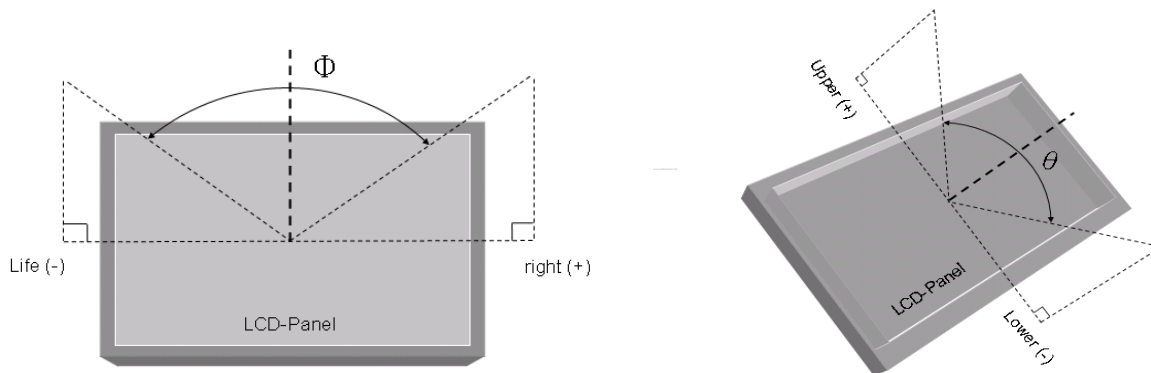

Fig8-2 Definition of Viewing Angle

\*5) Definition of Response Time.(White-Black)

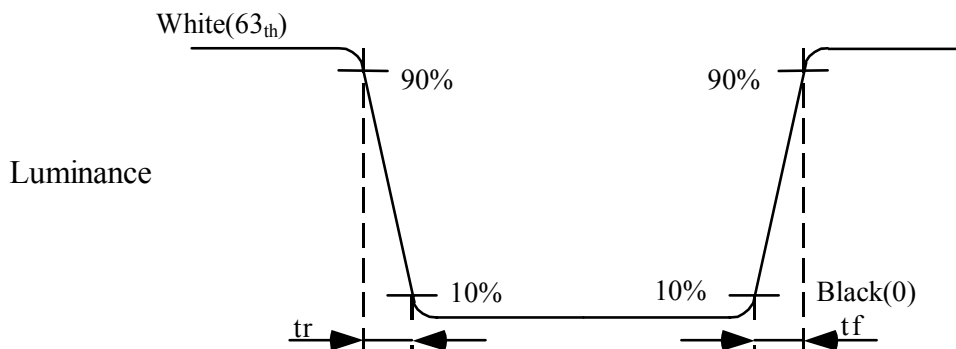

Fig9-3 Definition of Response Time(White-Black)

## 10. RELIABILITY TEST

### 10.1. Temperature and humidity

TEST ITEMS	CONDITIONS	NOTE
High Temperature Operation	70°C , 240Hrs	
High Temperature Storage	80°C , 240Hrs	
High Temperature High Humidity Operation	60°C , 90%RH , 240Hrs	No condensation
Low Temperature Operation	-20°C , 240Hrs	
Low Temperature Storage	-30°C , 240Hrs	
Thermal Shock	-30°C (0.5Hr) ~ 80°C(0.5Hr) 200 cycles	

### 10.2. Shock and Vibration

TEST ITEMS	CONDITIONS
Shock (Non-operation)	<ul style="list-style-type: none"> <li>● Shock level:980m/s<sup>2</sup>(equal to 100G)</li> <li>● Waveform:half sinusoidal wave,6ms.</li> <li>● Number of shocks:one shock input in each direction of three mutually perpendicular axes for a total of three shock inputs.</li> </ul>
Vibration (Non-operation)	<ul style="list-style-type: none"> <li>● Frequency range:8~33.3Hz</li> <li>● Stoke:1.3mm</li> <li>● Vibration: sinusoidal wave, perpendicular axis(both x, z axis:2Hrs,y axis:4Hrs).</li> <li>● Sweep:2.9G,33.3Hz-400Hz</li> <li>● Cycle:15min</li> </ul>

### 10.3 ESD

ITEM	CONDITION	NOTE
ESD	150pF , 330Ω , ±8KV&±15KV air test	【Note1】
	200pF , 0Ω , ±200V contact test	【Note2】

【Note1】 LCD glass and metal bezel

【Note2】 IF connector pins

### 10.4 Judgment standard

The Judgment of the above test should be made as follow:

Pass:Normal display image with no obvious non-uniformity and no line defect.Partial trasformation of the module parts should be ignored.

Fail:No display image,obvious non-uniformity,or line defect.