



# EP5388QI

800mA Synchronous Buck Regulator  
With Integrated Inductor  
3mm x 3mm x 1.1mm Package

July 2008  
RoHS Compliant  
Halogen Free

## Product Overview

The EP5388QI is a synchronous buck converter with integrated inductor, PWM controller, MOSFETS, and Compensation providing the smallest possible solution size. The EP5388QI requires only two small MLCC capacitors to make a complete solution. Integration of the inductor greatly simplifies design, contains noise, reduces part count, and reduces solution footprint. Low output ripple ensures compatibility with RF systems.

The EP5388QI operates at a switching frequency of 4 MHz, enabling this unprecedented level of integration and small external components. Type III voltage mode control is used to provide high noise immunity and wide control loop bandwidth.

The small footprint makes this part ideal for space constrained portable applications. Shutdown current of <1uA extends battery life. Output voltage level is programmed via a 3-pin VID selector providing seven pre-programmed output voltages along with an option for external resistor divider.

## Applications

- Noise Sensitive RF Applications
- Area Constrained Applications
- Wireless Data Applications
- Portable Gaming Devices
- Personal Media Players
- Advanced Mobile Processors, DSP, IO, Memory, Video, Multimedia Engines

## Ordering Information

Part Number	Temp Rating (°C)	Package
EP5388QI-T	-40 to +85	16-pin QFN T&R
EP5388QI-E	EP5388QI Evaluation Board	

## Product Highlights

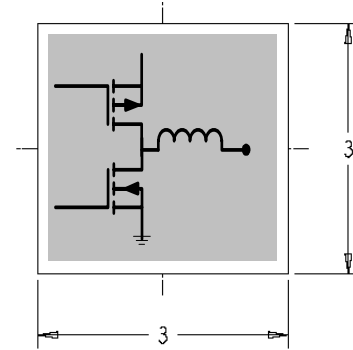

### Featuring Integrated Inductor Technology

- 3mm x 3mm x 1.1mm QFN package
- Only two low cost MLCC caps required
- 4 MHz switching frequency
- High efficiency, up to 94%
- Up to 800mA continuous output current
- Wide 2.4V to 5.5V input range
- $V_{OUT}$  range 0.6V to  $V_{IN} - 0.5V$
- 3-Pin VID output voltage programming
- 100% duty cycle capable
- Less than 1  $\mu A$  standby current
- Low  $V_{OUT}$  ripple for RF compatibility
- Short circuit and over current protection
- UVLO and thermal protection
- RoHS compliant; MSL 3 260°C reflow

## Typical Application Circuit

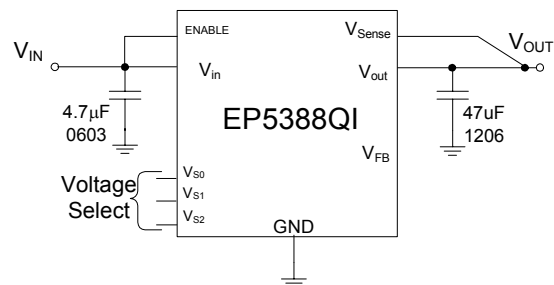

Figure 1. Typical application circuit.

Pin Description

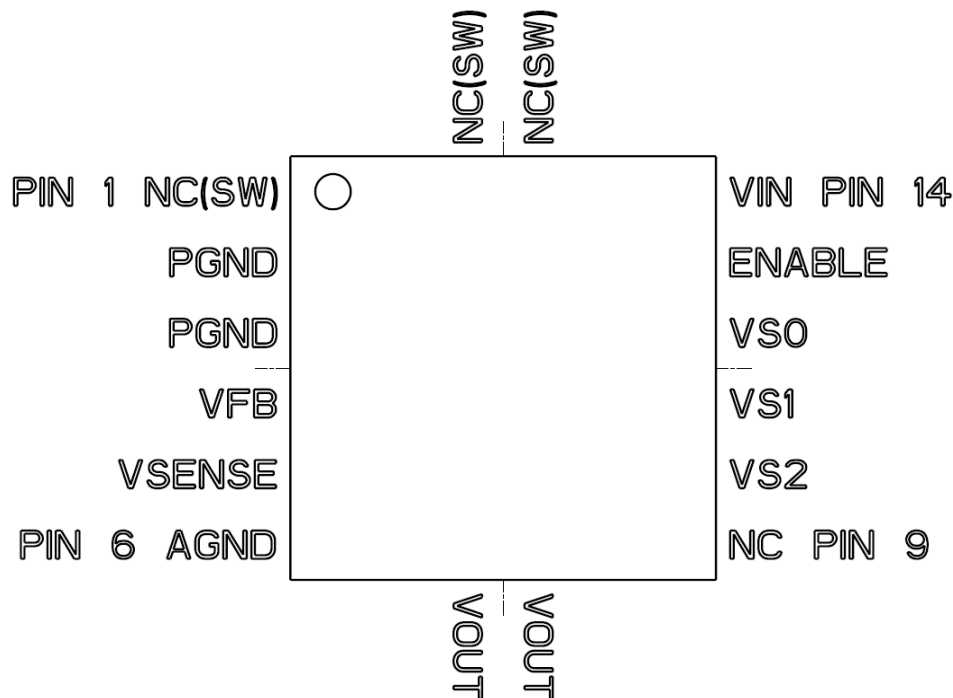

Figure 2. EP5388QI Package Pin-out.

PIN	NAME	FUNCTION
1, 15, 16	NC(SW)	No Connect. These pins are internally connected to the common switch node of the internal MOSFETs. NC(SW) pins are not to be electrically connected to any external signal, ground, or voltage. However, they must be soldered to the PCB. Failure to follow this guideline may result in part malfunction or damage.
2,3	PGND	Power Ground.
4	VFB	Feed back pin for external divider option. When using the external divider option (VS2=VS1=VS0= high) connect this pin to the center of the external divider. Set the divider such that $V_{FB} = 0.603V$ . The “ground” side of the external divider should be connected to AGND.
5	VSENSE	Sense pin for preset output voltages. Connect at the output capacitor.
6	AGND	Analog ground. This is the quiet ground for the internal control circuitry
7,8	VOUT	Regulated Output Voltage. Refer to application section for proper layout and decoupling.
9	NC	No Connect. This pin should not be electrically connected to any external signal, voltage, or ground.. This pin must be soldered to the PCB.
10, 11, 12	VS2,VS1,VS0	Output voltage select. VS2=pin10 VS1=pin11, VS0=pin12. Selects one of seven preset output voltages or choose external divider by connecting pins to logic high or low. (refer to section on output voltage select for more detail).
13	ENABLE	Output enable. Enable = logic high, disable = logic low.
14	VIN	Input voltage pin.

## Functional Block Diagram

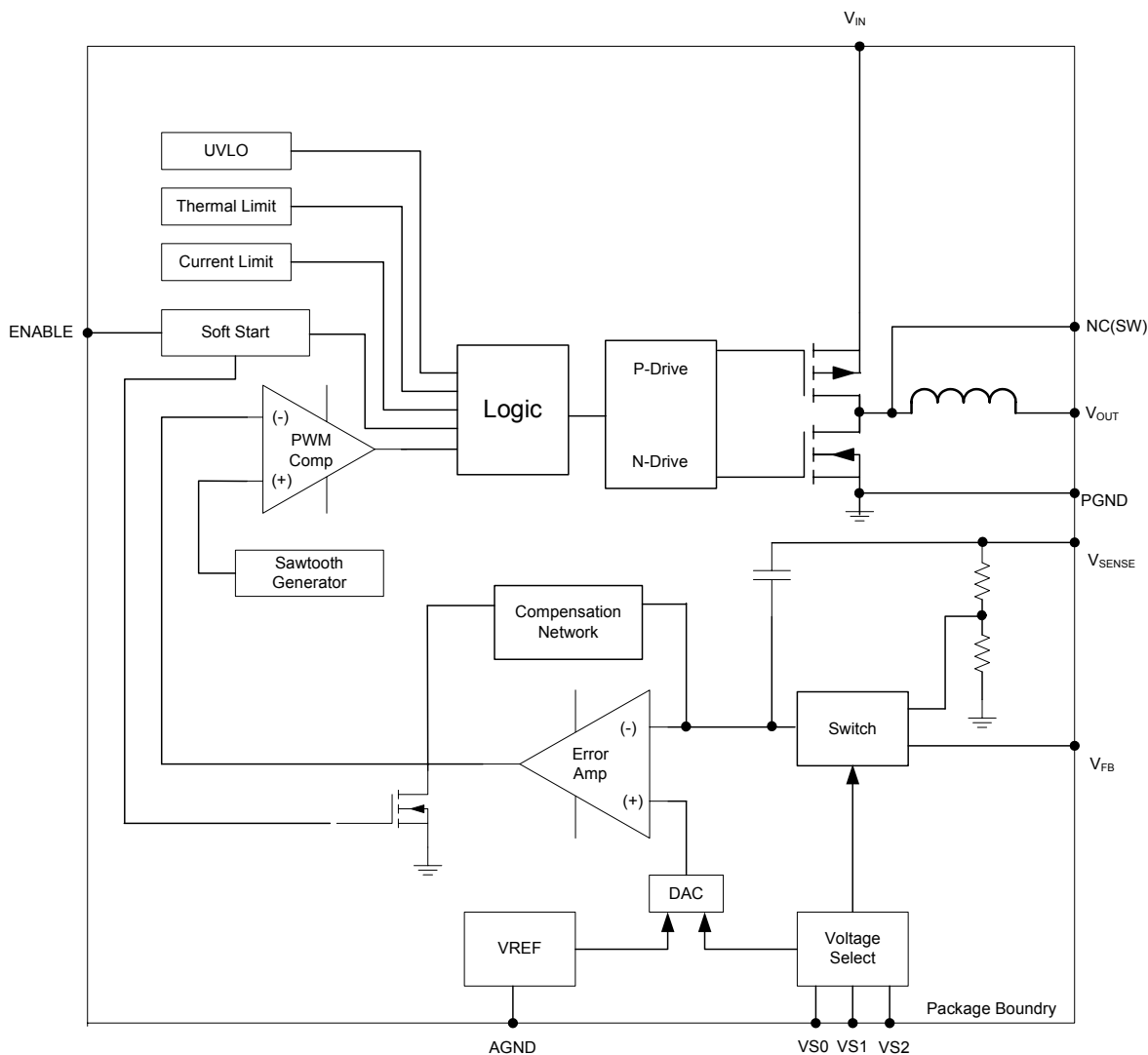

Figure 3. EP5388QI Functional block diagram.

## Absolute Maximum Ratings

CAUTION: Absolute Maximum ratings are stress ratings only. Functional operation beyond recommended operating conditions is not implied. Stress beyond absolute maximum ratings may cause permanent damage to the device. Exposure to absolute maximum rated conditions for extended periods may affect device reliability.

PARAMETER	SYMBOL	MIN	MAX	UNITS
Input Supply Voltage	$V_{IN}$	-0.3	7.0	V
Voltages on: ENABLE, $V_{SENSE}$ , $V_{S0}$ - $V_{S2}$		-0.3	$V_{IN} + 0.3$	V
Voltage on: $V_{FB}$		-0.3	2.7	V
Storage Temperature Range	$T_{STG}$	-65	150	°C
Reflow Temp, 10 Sec, MSL3 JEDEC J-STD-020C			260	°C
ESD Rating (based on Human Body Model)			2000	V

## Recommended Operating Conditions

PARAMETER	SYMBOL	MIN	MAX	UNITS
Input Voltage Range	$V_{IN}$	2.4	5.5	V
Output Voltage Range	$V_{OUT}$	0.603	$V_{IN} - 0.5$	V
Output Current	$I_{OUT}$	0	800	mA
Operating Ambient Temperature	$T_A$	-40	+85	°C
Operating Junction Temperature	$T_J$	-40	+125	°C

## Thermal Characteristics

PARAMETER	SYMBOL	TYP	UNITS
Thermal Resistance: Junction to Ambient (0 LFM)*	$\theta_{JA}$	100	°C/W
Thermal Shutdown Trip Point	$T_{J-TP}$	+150	°C
Thermal Shutdown Trip Point Hysteresis		15	°C

\* Based on a 2 oz. copper board and proper thermal design in line with JEDEC EIJ-JESD51 standards.

## Electrical Characteristics

NOTE:  $V_{IN} = 3.6V$ ,  $C_{IN} = 4.7\mu F$  0603 MLCC,  $C_{OUT} = 47\mu F$  1206 MLCC.  $T_A = -40^\circ C$  to  $+85^\circ C$  unless otherwise noted. Typical values are at  $T_A = 25^\circ C$ .

PARAMETER	SYMBOL	TEST CONDITIONS	MIN	TYP	MAX	UNITS
Under-Voltage Lockout	$V_{UVLO}$	$V_{IN}$ going low to high		2.2	2.3	V
UVLO Hysteresis				0.145		V
$V_{OUT}$ Initial Accuracy	$\Delta V_{OUT\_init}$	$T_A = 25^\circ C$ , $2.4V \leq V_{IN} \leq 5.5V$	-2		+2	%
Line Regulation	$\Delta V_{OUT\_line}$	$2.4V \leq V_{IN} \leq 5.5V$		0.06		%/V
Load Regulation	$\Delta V_{OUT\_load}$	$0A \leq I_{LOAD} \leq 800mA$		0.0003		%/mA
Temperature Variation	$\Delta V_{OUT\_temp}$	$-40^\circ C \leq T_A \leq +85^\circ C$		0.008		%/°C
Overall $V_{OUT}$ Accuracy (Line, Load, and Temperature combined)	$\Delta V_{OUT\_all}$	$2.4V \leq V_{IN} \leq 5.5V$ $-40^\circ C \leq T_A \leq +85^\circ C$ $0A \leq I_{LOAD} \leq 800mA$	-3		+3	%
Dynamic Voltage Slew Rate <sup>†</sup>	$V_{slew}$		1.125	1.5	1.875	V/mS
Continuous Output Current	$I_{OUT}$	$-20^\circ C \leq T_A \leq +85^\circ C$ $-40^\circ C \leq T_A \leq +85^\circ C$	800 750			mA
Shut-Down Current	$I_{SD}$	Enable = Low		0.75		μA
PFET OCP Threshold	$I_{LIM}$			1000		mA
Feedback Pin Voltage	$V_{FB}$	$2.4V \leq V_{IN} \leq 5.5V$ $-20^\circ C \leq T_A \leq +85^\circ C$ $0A \leq I_{LOAD} \leq 800mA$	0.585	0.603	0.621	V
Feedback Pin Input Current	$I_{FB}$			10		nA
VS2-VS0 Threshold	$V_{SX\_TH}$	Pin = Low Pin = High	0.0 1.4		0.4 $V_{IN}$	V
VS2-VS0 Pin Input Current	$I_{VSX}$			1		nA
Enable Pin Voltage Thresholds	$V_{EN\_TH}$	Pin = Low Pin = High	0.0 1.4		0.2 $V_{IN}$	V
Enable Pin Input Current	$I_{EN}$	ENABLE = $V_{in} = 3.6V$		2		μA
Operating Frequency	$F_{OSC}$			4		MHz
PFET On Resistance	$R_{DS(ON)}$			340		mΩ
NFET On Resistance	$R_{DS(ON)}$			270		mΩ
Dropout Resistance	$R_{DROPOUT}$			450		mΩ

PARAMETER	SYMBOL	TEST CONDITIONS	MIN	TYP	MAX	UNITS
<b>Soft-Start Operation</b>						
Soft-Start Slew Rate†	$V_{SS}$		1.125	1.5	1.875	V/mS
Time to 90% $V_{out}$	$T_{SS}$	$V_{out} = 3.3V$		2		mS

† Parameter guaranteed by design.

## Typical Performance Characteristics

Typical performance characteristics are measured using the application circuit in Figure 1. All measurements made at 25°C.

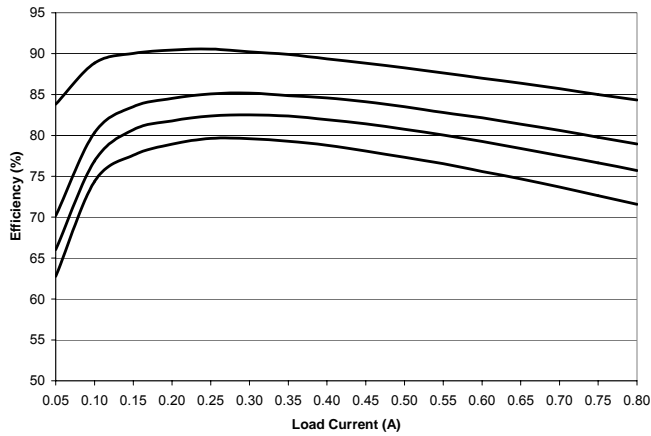

**Efficiency,  $V_{IN} = 3.3V$ ,  $V_{OUT} = 2.5V, 1.8V, 1.5V, 1.2V$ , top to bottom.**

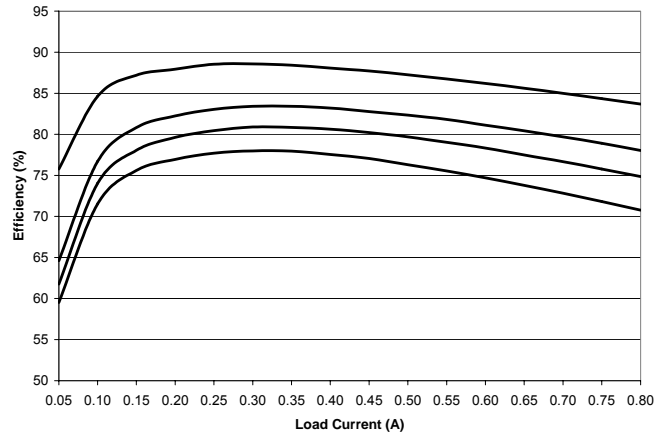

**Efficiency,  $V_{IN} = 3.7V$ ,  $V_{OUT} = 2.5V, 1.8V, 1.5V, 1.2V$ , top to bottom.**

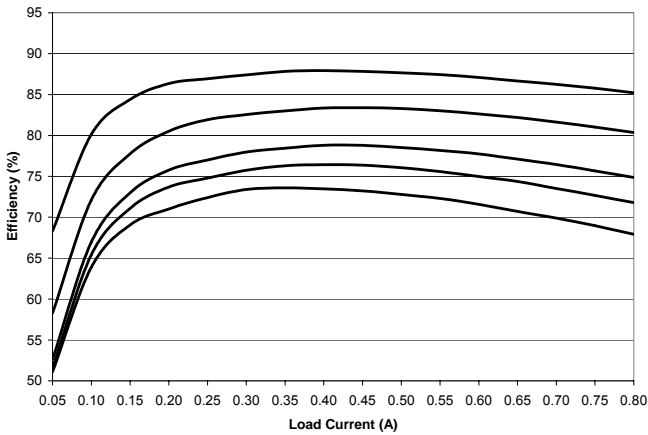

**Efficiency,  $V_{IN} = 5V$ ,  $V_{OUT} = 3.3V, 2.5V, 1.8V, 1.5V, 1.2V$ , top to bottom.**

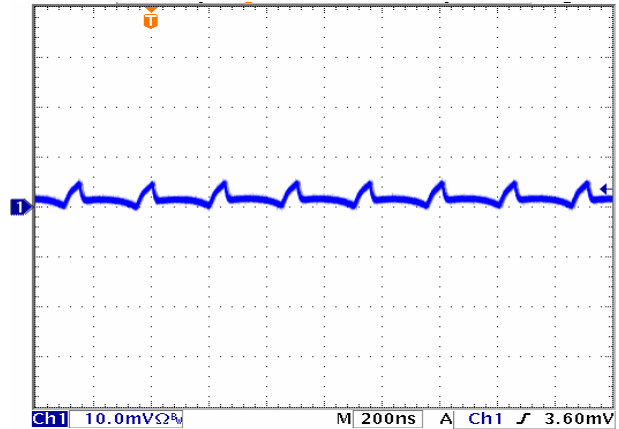

**Output Ripple,  $V_{IN} = 5V$ ,  $V_{OUT} = 1.2V$ ; Load = 500mA.**

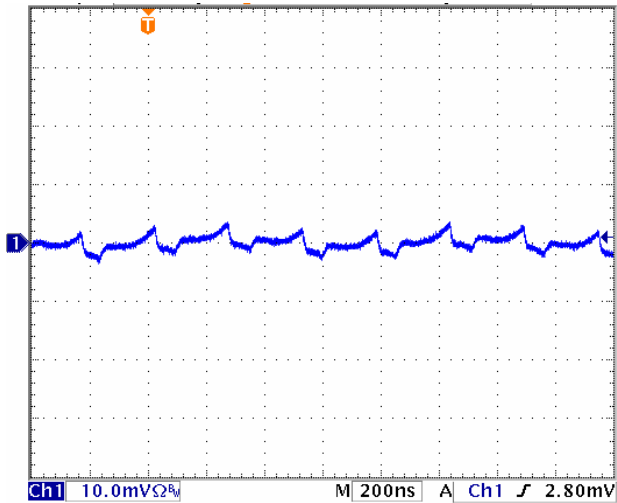

Output Ripple,  $V_{IN} = 5V$ ,  $V_{OUT} = 3.3V$ ; Load = 500mA.

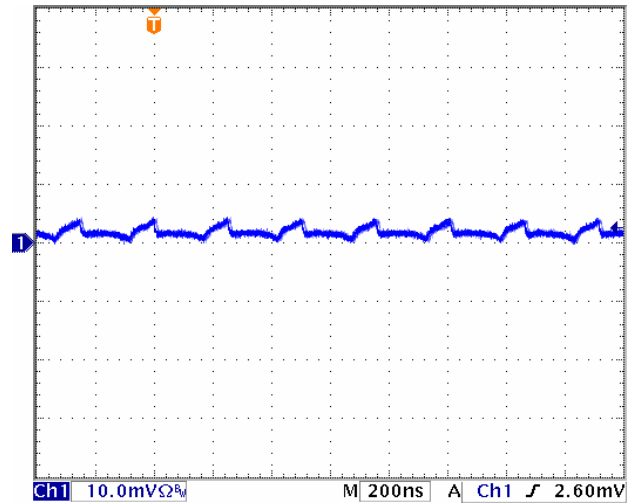

Output Ripple,  $V_{IN} = 3.3V$ ,  $V_{OUT} = 1.2V$ ; Load = 500mA.

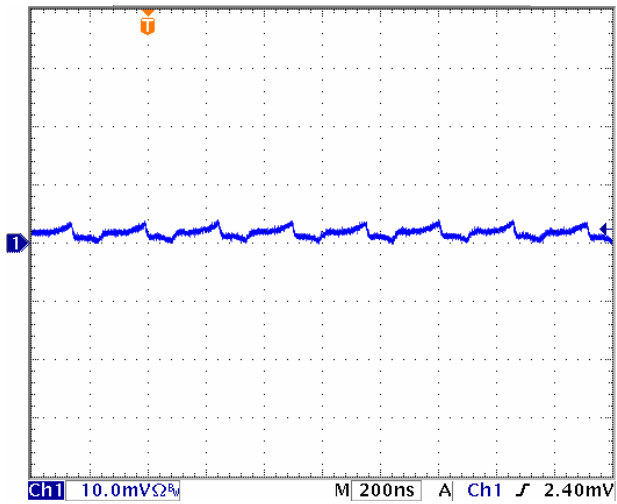

Output Ripple,  $V_{IN} = 3.3V$ ,  $V_{OUT} = 1.8V$ ; Load = 500mA.

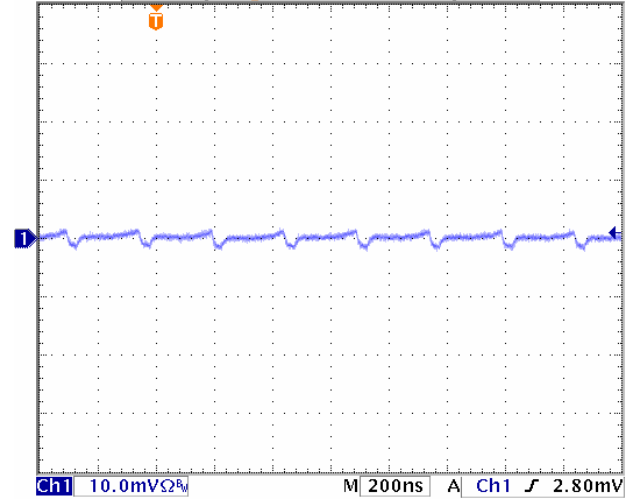

Output Ripple,  $V_{IN} = 3.3V$ ,  $V_{OUT} = 2.5V$ ; Load = 500mA.

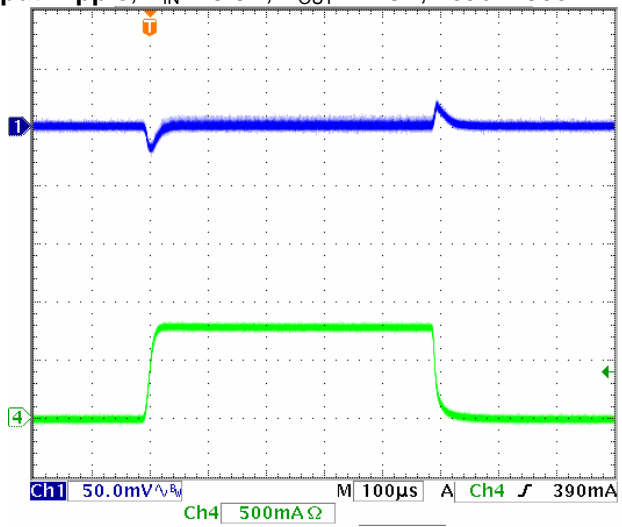

Transient,  $V_{IN} = 5.0V$ ,  $V_{OUT} = 1.2V$ , Load = 0-800mA.

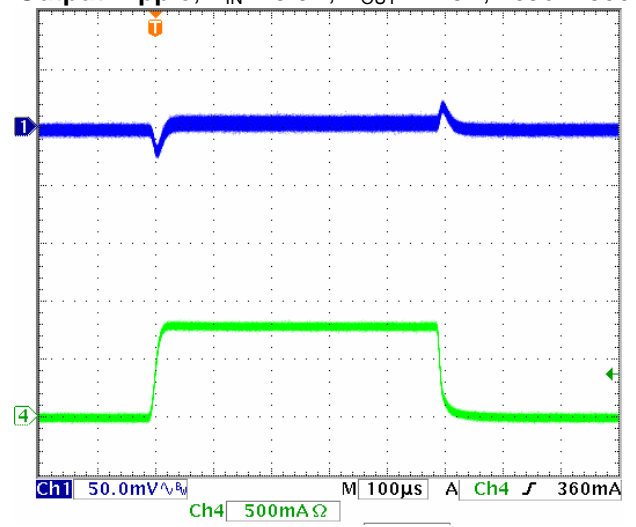

Transient,  $V_{IN} = 5.0V$ ,  $V_{OUT} = 3.3V$ , Load = 0-800mA.

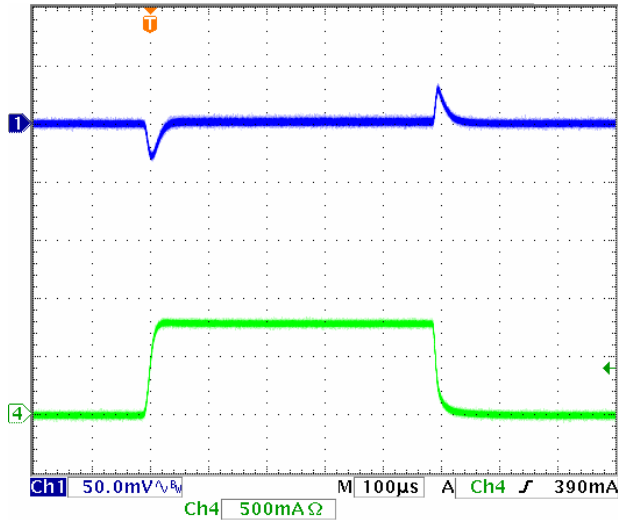

Transient,  $V_{IN} = 3.3V$ ,  $V_{OUT} = 1.2V$ , Load = 0-800mA.

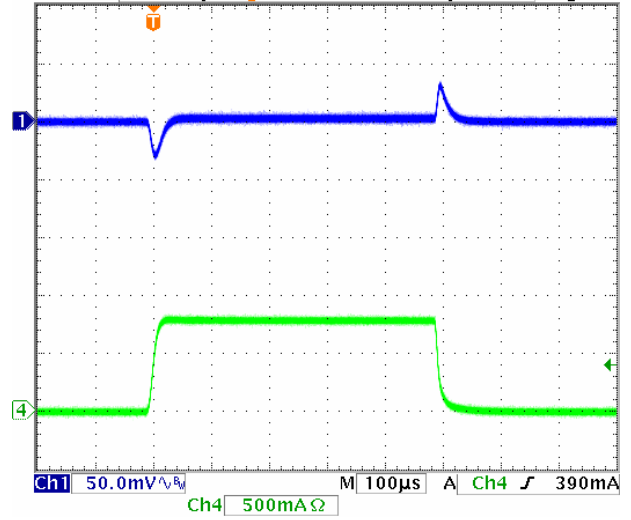

Transient,  $V_{IN} = 3.3V$ ,  $V_{OUT} = 1.8V$ , Load = 0-800mA.

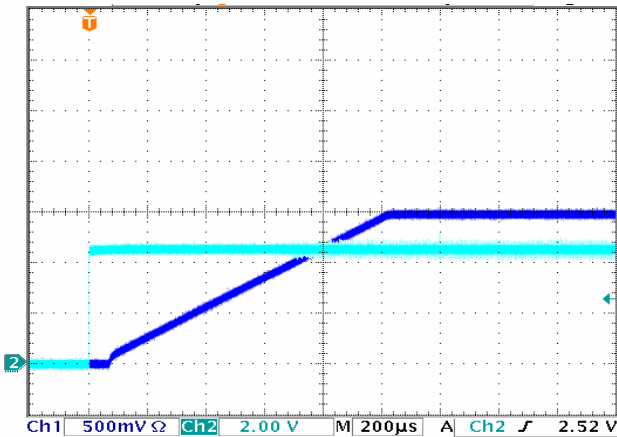

Startup,  $V_{IN} = 3.6V$ ,  $V_{OUT} = 1.5V$ , Load = 500mA.  
Enable in light blue;  $V_{OUT}$  in Dark blue.

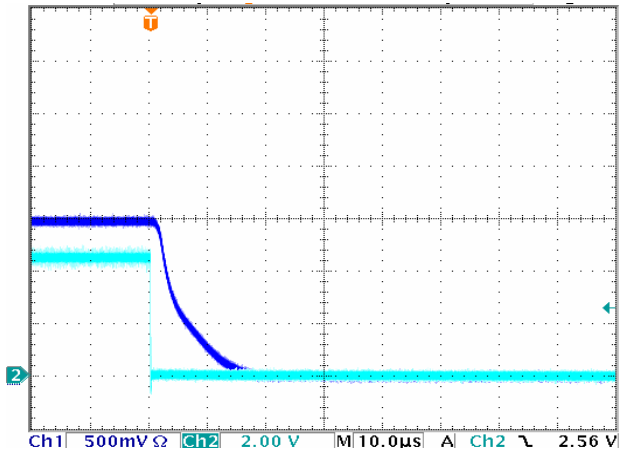

Shutdown,  $V_{IN} = 3.6V$ ,  $V_{OUT} = 1.5V$ , Load = 500mA.  
Enable in light blue;  $V_{OUT}$  in Dark blue.

## Detailed Description

### Functional Overview

The EP5388QI is a complete DCDC converter solution requiring only two low cost MLCC capacitors. MOSFET switches, PWM controller, Gate-drive, compensation, and inductor are integrated into the tiny 3mm x 3mm x 1.1mm package to provide the smallest footprint possible while maintaining high efficiency, low ripple, and high performance. The converter uses voltage mode control to provide the simplest implementation and high noise immunity. The device operates at a 4MHz switching frequency. The high switching frequency allows for a wide control loop

bandwidth providing excellent transient performance. The high switching frequency further enables the use of very small components making possible this unprecedented level of integration.

Enpirion's proprietary power MOSFET technology provides very low switching loss at frequencies of 4 MHz and higher, allowing for the use of very small internal components, and high performance. Integration of the magnetics virtually eliminates the design/layout issues normally associated with switch-mode DCDC converters. All of this enables much easier and faster incorporation into various applications to meet demanding requirements.

Output voltage is chosen from seven preset values via a three pin VID voltage select scheme. An external divider option enables the selection of any voltage in 0.603V to  $V_{IN}-0.5V$  range. This reduces the number of components that must be qualified and reduces inventory burden. The VID pins can be toggled on the fly to implement glitch free dynamic voltage scaling between any two of the seven preset VID voltage levels.

Protection features include under-voltage lock-out (UVLO), over-current protection (OCP), short circuit protection, and thermal overload protection.

### Integrated Inductor

Enpirion has introduced the world's first product family featuring integrated inductors. The EP5388QI utilizes a proprietary low loss integrated inductor. The use of an internal inductor localizes the noises associated with the output loop currents. The inherent shielding and compact construction of the integrated inductor reduces the radiated noise that couples into the traces of the circuit board. Further, the package layout is optimized to reduce the electrical path length for the AC ripple currents that are a major source of radiated emissions from DCDC converters. The integrated inductor significantly reduces parasitic effects that can harm loop stability, and makes layout very simple.

### Stable Over Wide Range of Operating Conditions

The EP5388QI utilizes an internal type III compensation network and is designed to provide a high degree of stability over a wide range of operating conditions. The device operates over the entire input and output voltage range with no external modifications required. The very high switching frequency allows for a very wide control loop bandwidth.

### Soft Start

Internal soft start circuits limit in-rush current when the device starts up from a power down condition or when the "ENABLE" pin is asserted "high". Digital control circuitry limits the  $V_{OUT}$  ramp rate to levels that are safe for the Power MOSFETS and the integrated inductor. The soft start ramp rate is nominally 1.5V/mS.

### Over Current/Short Circuit Protection

When an over current condition occurs,  $V_{OUT}$  is pulled low. This condition is maintained for a period of approximately 1.2 ms and then a normal soft start cycle is initiated. If the over current condition still persists, this cycle will repeat.

### Under Voltage Lockout

During initial power up an under voltage lockout circuit will hold-off the switching circuitry until the input voltage reaches a sufficient level to insure proper operation. If the voltage drops below the UVLO threshold the lockout circuitry will again disable the switching. Hysteresis is included to prevent chattering between states.

### Enable

The ENABLE pin provides a means to shut down the converter or enable normal operation. Transitioning from low to high will cause the converter to go through a soft start cycle. Transitioning from high to a low will cause the device to discharge the output and then shutdown. In shutdown mode, the device quiescent current will be less than 1 uA.

**NOTE:** This pin must not be left floating.



## Thermal Shutdown

When excessive power is dissipated in the chip, the junction temperature rises. Once the junction temperature exceeds the thermal

shutdown temperature the thermal shutdown circuit turns off the converter thus allowing the device to cool. When the junction temperature decreases by 15°C, the device will go through the normal startup process.

## Application Information

Table 2. VID voltage select settings.

VS2	VS1	VS0	V <sub>OUT</sub>
0	0	0	3.3V
0	0	1	2.5V
0	1	0	1.8V
0	1	1	1.5V
1	0	0	1.25V
1	0	1	1.2V
1	1	0	0.8V
1	1	1	User Selectable

## Output Voltage Select

To provide the highest degree of flexibility in choosing output voltage, the EP5388QI uses a 3 pin VID, or Voltage ID, output voltage select arrangement. This allows the designer to choose one of seven preset voltages, or to use an external voltage divider. Internally, the output of the VID multiplexer sets the value for the voltage reference DAC, which in turn is connected to the non-inverting input of the error amplifier. This allows the use of a single feedback divider with constant loop gain and optimum compensation, independent of the output voltage selected.

Table 1 shows the various VS2-VS0 pin logic states and the associated output voltage levels. A logic “1” indicates a connection to V<sub>IN</sub> or to a “high” logic voltage level. A logic “0” indicates a connection to ground or to a “low” logic voltage level. These pins can be either hardwired to V<sub>IN</sub> or GND or alternatively can be driven by standard logic levels. Logic low is defined as V<sub>SX</sub> ≤ 0.4V. Logic high is defined as 1.4V ≤ V<sub>SX</sub> ≤ V<sub>IN</sub>. Any level between these two values is indeterminate. These pins must not be left floating.

## External Voltage Divider

As described above, the external voltage divider option is chosen by connecting the VS0, VS1, and VS2 pins to V<sub>IN</sub> or logic high. The EP5388QI uses a separate feedback pin, V<sub>FB</sub>, when using the external divider. V<sub>SENSE</sub> must be connected to V<sub>OUT</sub> as indicated in Figure 4.

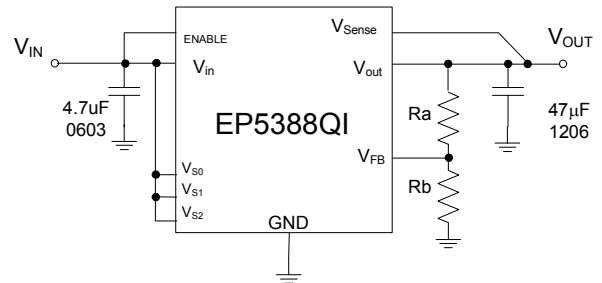

Figure 4. External Divider application circuit.

The output voltage is nominally selected by the following formula:

$$V_{OUT} = 0.603V \left( 1 + \frac{R_a}{R_b} \right)$$

Then R<sub>b</sub> is given as:

$$R_b = \frac{0.603 \times R_a}{V_{OUT} - 0.603} \Omega$$

R<sub>a</sub> must be chosen as nominally 200KΩ to maintain loop gain. V<sub>OUT</sub> can be programmed over the range of 0.603V to V<sub>IN</sub>-0.5V.

## Dynamically Adjustable Output

The EP5388QI is designed to allow for dynamic switching between the seven predefined VID voltage levels. The inter-

voltage slew rate is optimized to prevent excess undershoot or overshoot as the output voltage levels transition. The slew rate is identical to the soft-start slew rate of 1.5V/mS.

Dynamic transitioning between internal VID settings and the external divider is not allowed.

## Input and Output Capacitors

The **input** capacitance requirement is 4.7uF 0603 MLCC. Enpirion recommends that a low ESR MLCC capacitor be used.

A variety of **output** capacitor configurations are possible depending on footprint and ripple requirements. For typical applications, it is recommended to use a single 47uF 1206 MLCC capacitor. Ripple performance can be improved by using 2 x 22uF 0805 MLCC capacitors.

A single 10uF 0805 MLCC can be used if  $V_{OUT}$  programming is accomplished using an external resistor divider, with the addition of a 10pF phase lead capacitor as shown in Figure

5. Note that in this configuration,  $V_{SENSE}$  should NOT be connected to  $V_{OUT}$ .  $R_a$  and  $R_b$  values are calculated as shown in the external voltage divider section.

The **input** and the **output** capacitor must use a X5R or X7R or equivalent dielectric formulation. Y5V or equivalent dielectric formulations lose capacitance with frequency, bias voltage, and temperature and are not suitable for switch-mode DC-DC converter output filter applications.

Contact Enpirion Applications for information on other output capacitor usage.

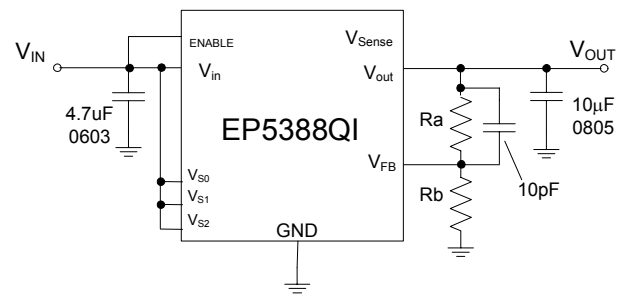

**Figure 5.** Applications circuit for  $C_{OUT} = 1 \times 10\mu\text{F}$  0805.

## Layout Considerations\*

\*Optimized PCB layout file is downloadable from the Enpirion website to assure first pass design success.

Refer to figure 6 for the following layout recommendations.

**Recommendation 1:** The input and output filter capacitors should be placed as close to the EP5388QI as possible to reduce EMI from input and output loop AC currents. This reduces the physical area of these AC current loops.

**Recommendation 2:** The system ground plane should be the first layer immediately below the surface layer (PCB layer 2). If it is not possible to make PCB layer 2 the system ground plane, a local ground island should be created on PCB layer 2 under the Enpirion device and including the area under the input and output filter capacitors. This ground plane, or ground island, should be continuous and uninterrupted underneath the Enpirion device and the input and output filter capacitors.

**Recommendation 3:** The surface layer ground pour should include a “slit” as shown in figure 6 to separate the input and output AC loop currents. This will help reduce noise coupling from the input current loop to the output current loop.

**Recommendation 4:** Multiple small vias (approximately 0.25mm finished diameter) should be used to connect the ground terminals of the input and output capacitors, and the surface ground pour under the device, to the system ground plane. If a local ground island is used on PCB layer 2, the via should connect to the ground island and continue down to the PCB system ground plane.

**Recommendation 5:** The AGND pin should be connected to the system ground plane using a via as described in recommendation 4. AGND must NOT be connected to the surface layer ground pour.

**Recommendation 6:** As with any switch-mode DC-DC converter, do not run any sensitive signal or control lines under the converter package.

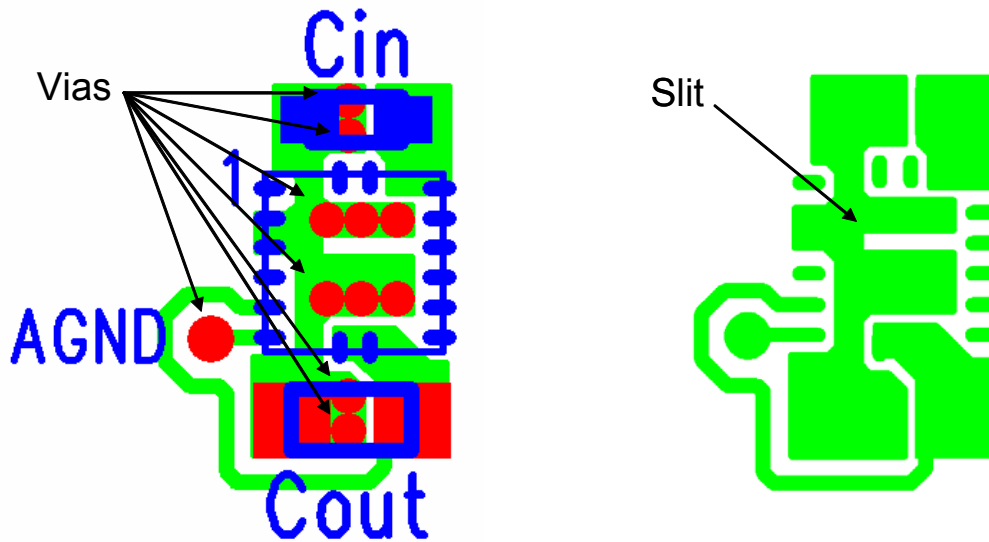
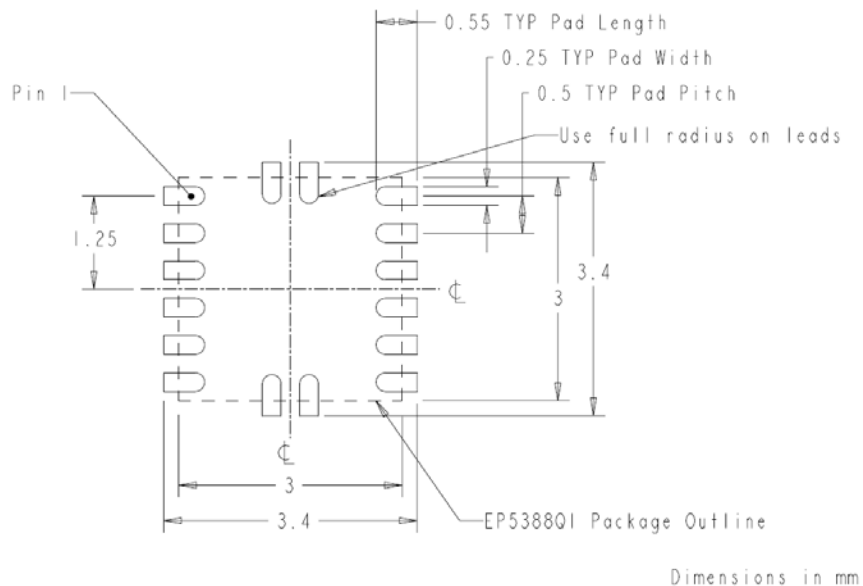

Figure 6. PCB layout recommendation.

## Recommended PCB Footprint





# Package Dimensions

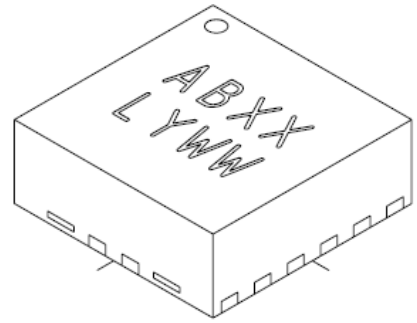
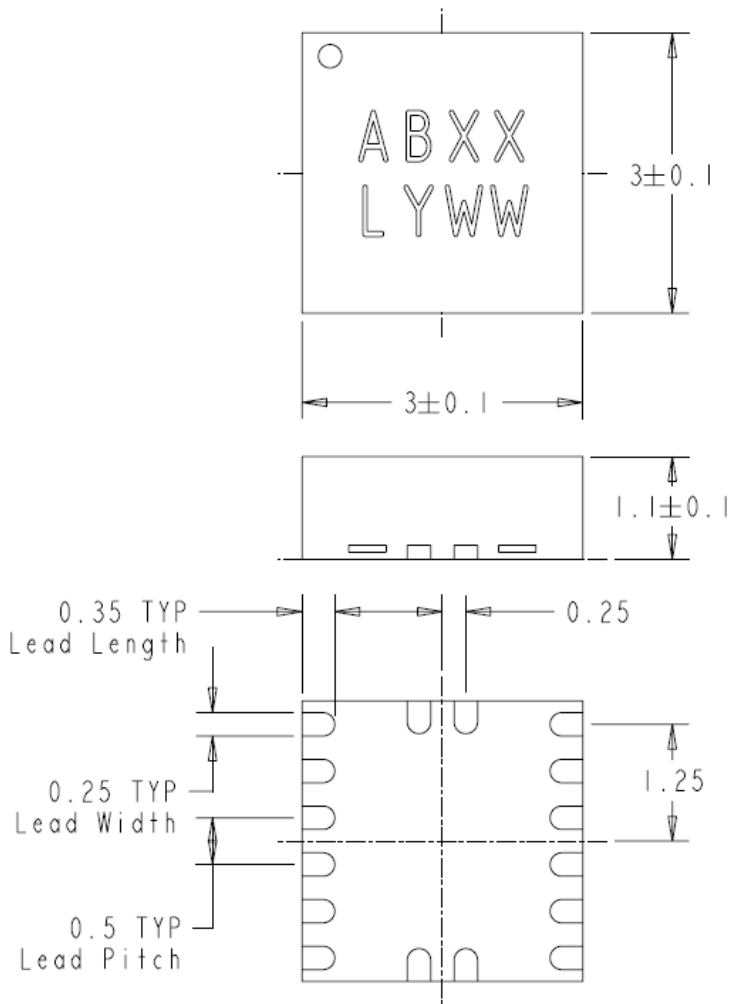

Dimensions in mm

## Contact Information

Enpirion, Inc.  
685 US Route 202/206 Suite 305  
Bridgewater, NJ 08807  
Phone: +1 908-575-7550  
Fax: +1 908-575-0775

*Enpirion reserves the right to make changes in circuit design and/or specifications at any time without notice. Information furnished by Enpirion is believed to be accurate and reliable. Enpirion assumes no responsibility for its use or for infringement of patents or other third party rights, which may result from its use. Enpirion products are not authorized for use in nuclear control systems, as critical components in life support systems or equipment used in hazardous environment without the express written authority from Enpirion.*