

Data Sheet

Description

Avago Technologies AFEM-S105 WiFi FEM includes power amplifier, directional coupler, and SPDT antenna switch. It is designed for mobile and fixed wireless data applications in the 5.15 to 5.85 GHz frequency ranges. The PA is optimized for IEEE 802.11 a/n WiFi modulation. The PA exhibits flat gain and good match while providing linear power efficiency to meet stringent mask conditions. It utilizes Avago Technologies proprietary GaAs Enhancement-mode pHEMT technology for superior performance across voltage and temperature levels.

The AFEM-S105 is packaged in a 3.2 x 3.2 x 0.6 mm size for space-constrained applications.

Functional Block Diagram (Top View)

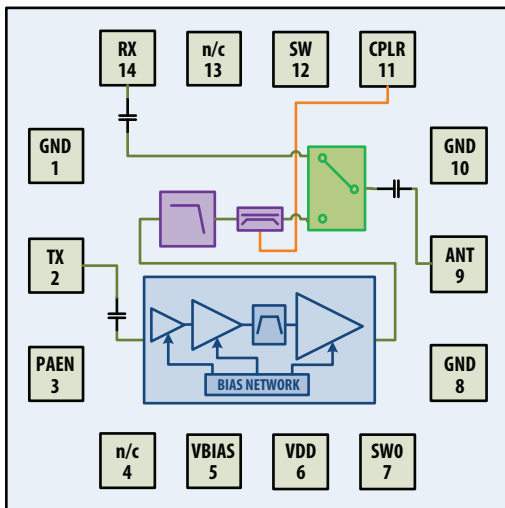

Attention: Observe precautions for handling electrostatic sensitive devices.
ESD Machine Model = 50 V
ESD Human Body Model = 450 V
Refer to Avago Application Note A004R:
Electrostatic Discharge, Damage and Control.

Features

- 50 Ω all RF ports
- Integrated directional coupler, -17 dB coupling factor, > 14 dB directivity
- High Tx – Rx switch isolation
- 3 to 4.2 V supply
- Small size: 3.2 x 3.2 x 0.6 mm
- Stable under all loads or conditions
- Gain of 28 dB
- Meets 802.11a/n emission mask requirements @ 15 dBm
- Meets FCC 15.205 emission requirements @ 15 dBm
- EVM < -32.5 dB at 15dBm, < -35 dB at 12 dBm
- Idd < 105 mA @ 15 dBm Pout
- PAE(PA) > 21% @ Pout (ANT) = 15 dBm
- Only 1 external component required

Applications

- Portable WiFi applications
- WiFi Access points

Package Diagram (Bottom View)

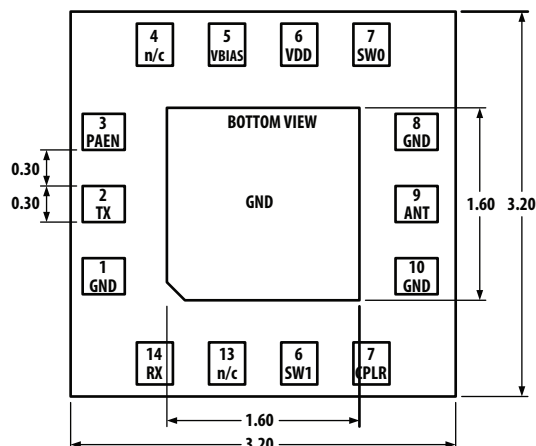

ELECTRICAL SPECIFICATIONS

Absolute Minimum and Maximum Ratings

Table 1. Minimum and Maximum Ratings

Parameter		Specifications			
Description	Pin	Min.	Max.	Unit	Comments
Supply Voltage	VCC		5.5	V	
Bias Supply	VBIAS		5.5	V	
PA enable	PAEN		4.5	V	
Switch Control	SW0, SW1		4.5	V	
RF Input Power	RFIN		15	dBm	
Channel Temperature			150	°C	
Storage Temperature		-65	150	°C	

Table 2. Operating Range

Parameter		Specifications				
Description	Pin	Min.	Typical	Max.	Unit	Comments
Supply Voltage	VCC	3.0	3.3	4.2	V	
Bias Supply	VBIAS	3.0	3.3	4.2	V	
				16	mA	
PA enable	PAEN	2.7	2.9	3.3	V	
				2.0	mA	
Switch Control	SW0	2.7	2.9	3.6	V	RX Mode
				200	μA	
	SW1	2.7	2.9	3.6	V	TX Mode
				200	μA	
RF Output Power	ANT		15		dBm	
Frequency Range		5.15		5.85	GHz	
Thermal Resistance, θ_{jC}			29.8		°C/W	Channel to board
Case Temperature		-30		+85	°C	

Electrical Specifications

All data measured on an Avago demo board at $V_{dd} = 3.3\text{ V}$, $T_c = 25^\circ\text{ C}$, $50\ \Omega$ at all ports. Unless otherwise specified, all data is taken at 54 Mbps 64QAM modulated signal per IEEE 802.11a with 20 MHz BW at 5.15 – 5.85 GHz. For TX mode $PAEN = SW1 = 2.9\text{ V}$, $SW0 = 0\text{ V}$. For RX mode $SW0 = 2.9\text{ V}$, $PAEN = SW1 = 0\text{ V}$.

Table 3. RF Electrical Characteristics

Parameter	Performance			Unit	Comments
	Min.	Typical	Max.		
Input Return Loss		-15		dB	TX and RX ports
Antenna Switch Switching Time		100		nS	
WiFi TX Path					
Gain	25	28		dB	
Gain Variation over any 20 MHz		± 0.25		dB	
Mask compliant OFDM output power	15			dBm	.11a 64QAM
EVM		-32.5	-31.0	dB	Pout = 15 dBm
		-35			Pout = 12 dBm
Total DC Current		105	120	mA	Pout = 15 dBm
		85			Pout = 12 dBm
PAE @ PA output		21		%	Pout = 15 dBm
		14			Pout = 12 dBm
Harmonics		-43		dBm/MHz	Pout = 15 dBm
Coupler coupling factor		-17		dB	@ 5850 MHz
Coupler directivity		14		dB	
PA Turn-On Time		125		nS	
WiFi Rx Path					
Insertion Loss (In-Band)		1.3		dB	
Isolation ANT/RX in WiFi TX mode		28		dB	

Table 4. Control Logic Truth Table

Mode	SW0	SW1	PAEN
RX	1	0	0
TX	0	1	1
FEM OFF	0	0	0

Selected Performance Plots

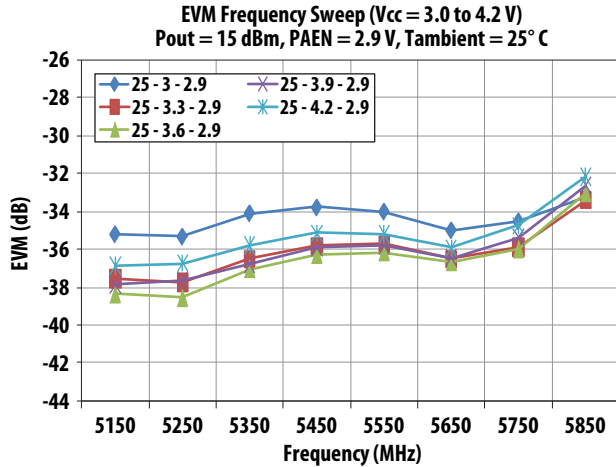

Figure 1. EVM Frequency Sweep at 25° C and $P_{out} = 15$ dBm over V_{cc}

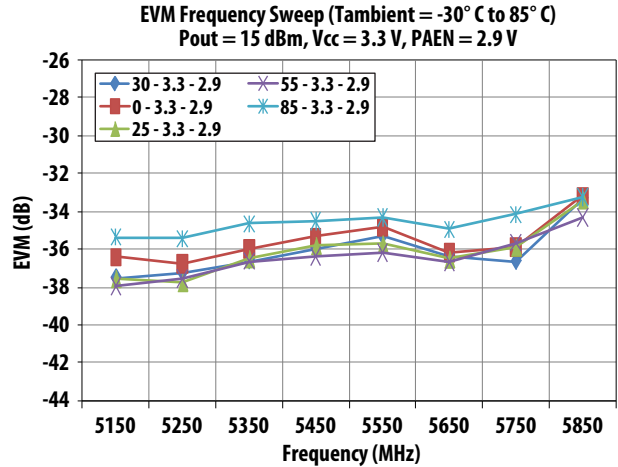

Figure 2. EVM Frequency Sweep at $V_{cc} = 3.3$ V and $P_{out} = 15$ dBm over Tambien

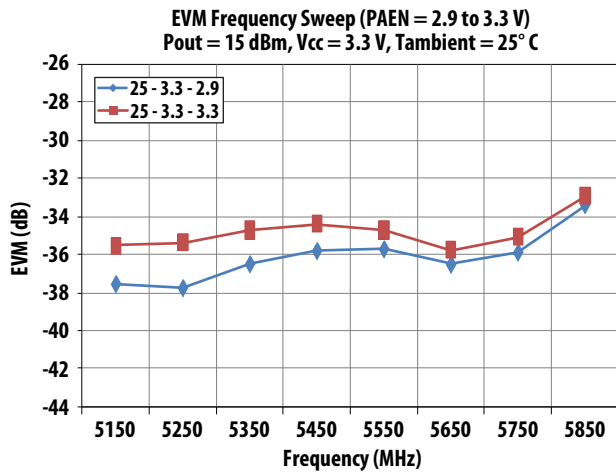

Figure 3. EVM Frequency Sweep at $V_{cc} = 3.3$ V and $P_{out} = 15$ dBm over PAEN

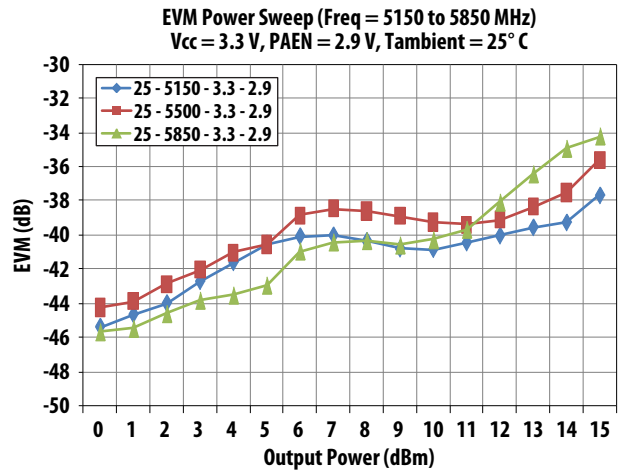

Figure 4. EVM Power Sweep at $V_{cc} = 3.3$ V and 25° C over Frequency

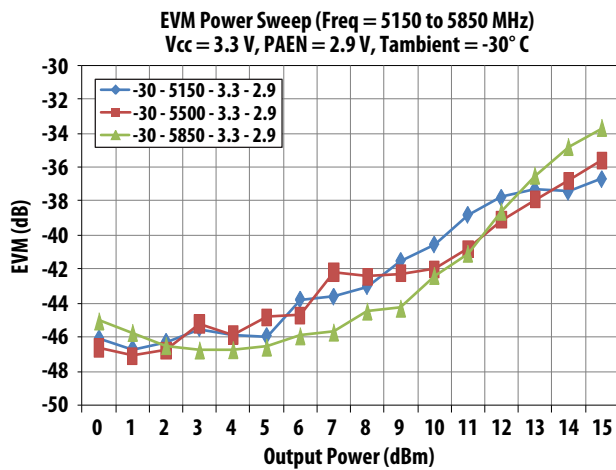

Figure 5. EVM Power Sweep at $V_{cc} = 3.3$ V and -30° C over Frequency

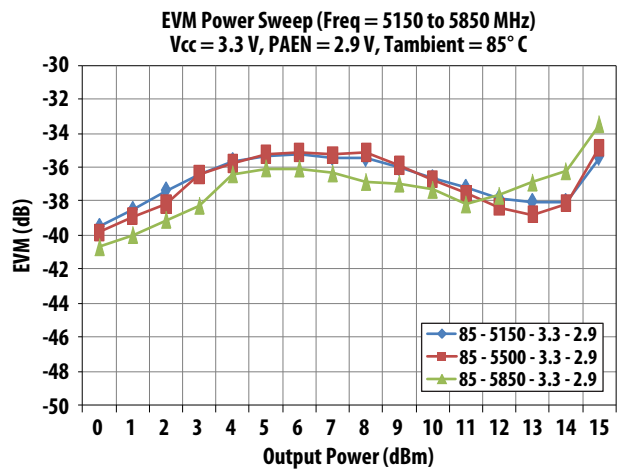

Figure 6. EVM Power Sweep at $V_{cc} = 3.3$ V and 85° C over Frequency

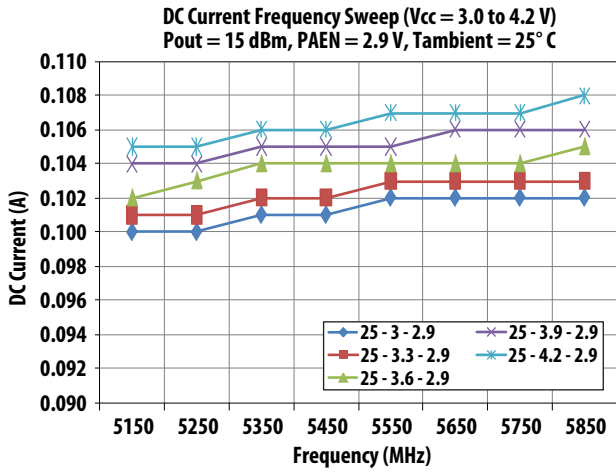

Figure 7. DC Current Frequency Sweep at 25° C and Pout = 15 dBm over Vcc

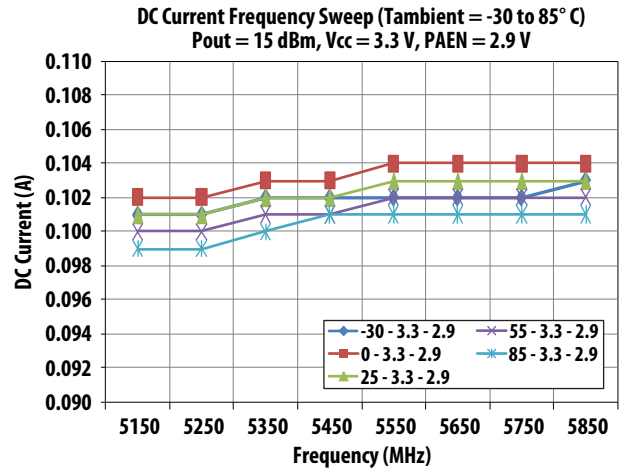

Figure 8. DC Current Frequency Sweep at Vcc = 3.3 V and Pout = 15 dBm over Tambient

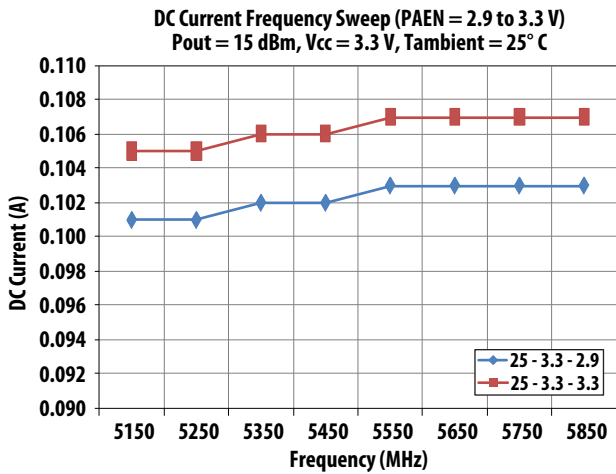

Figure 9. DC Current Frequency Sweep at Vcc = 3.3 V and Pout = 15 dBm over PAEN

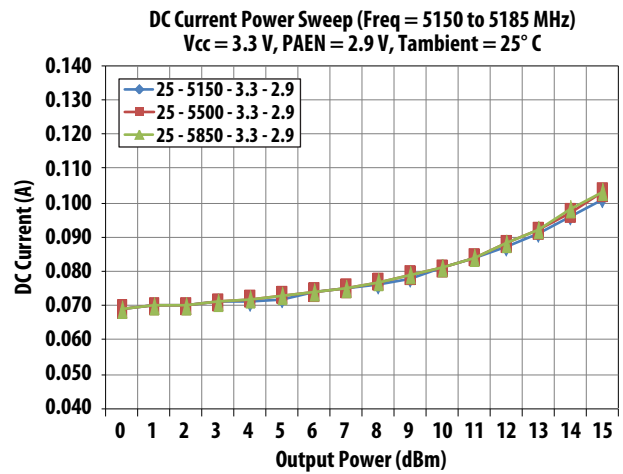

Figure 10. DC Current Power Sweep at Vcc = 3.3 V and 25° C over Frequency

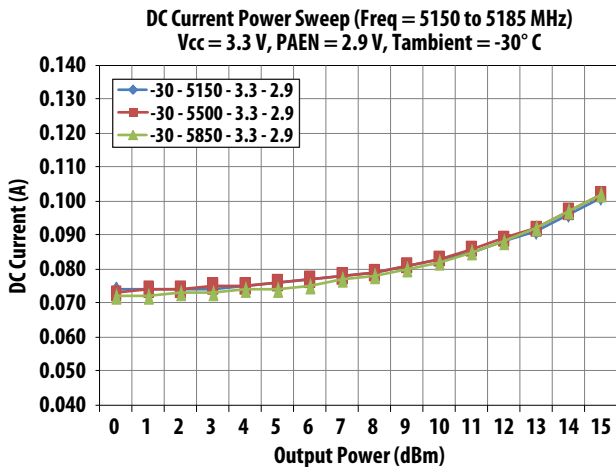

Figure 11. DC Current Power Sweep at Vcc = 3.3 V and -30° C over Frequency

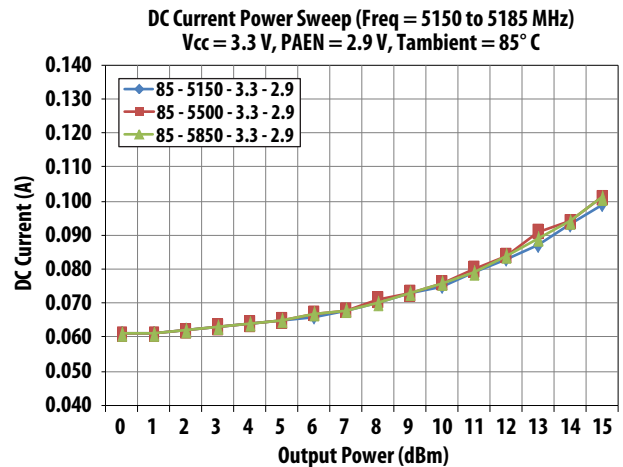

Figure 12. DC Current Power Sweep at Vcc = 3.3 V and 85° C over Frequency

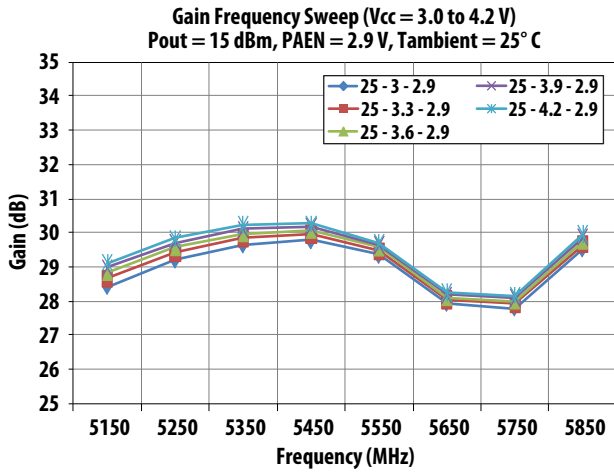

Figure 13. Gain Frequency Sweep at 25°C and $P_{out} = 15$ dBm over V_{cc}

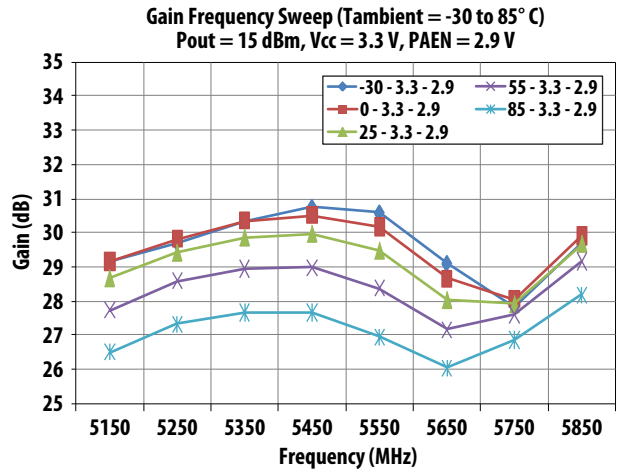

Figure 14. Gain Frequency Sweep at $V_{cc} = 3.3$ V and $P_{out} = 15$ dBm over Tambient

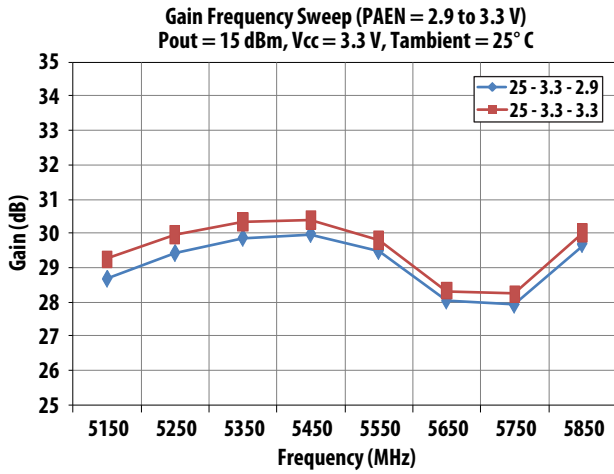

Figure 15. Gain Frequency Sweep at $V_{cc} = 3.3$ V and $P_{out} = 15$ dBm over PAEN

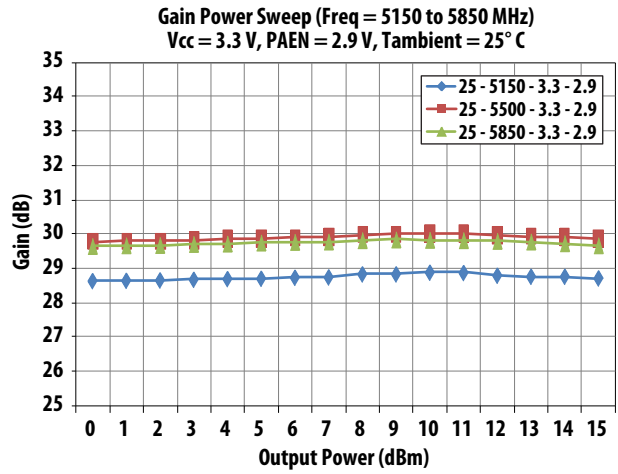

Figure 16. Gain Power Sweep at $V_{cc} = 3.3$ V and 25°C over Frequency

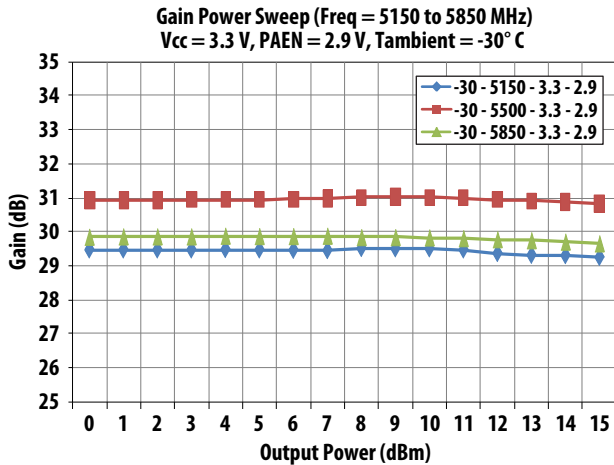

Figure 17. Gain Power Sweep at $V_{cc} = 3.3$ V and -30°C over Frequency

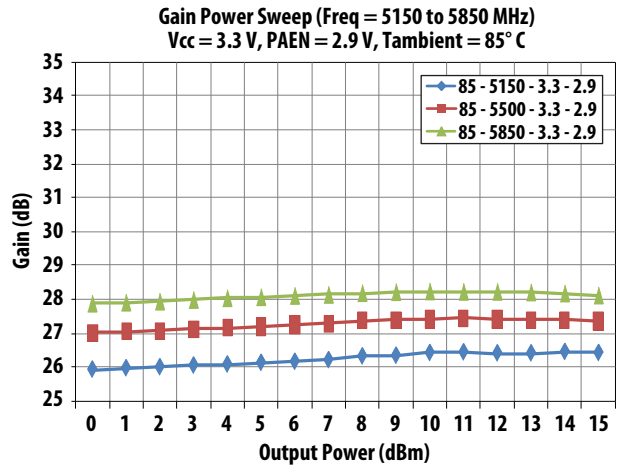

Figure 18. Gain Power Sweep at $V_{cc} = 3.3$ V and 85°C over Frequency

Evaluation Board Description

Table 5. Pin Description:

Top Pin No.	Function	Bottom Pin No.	Function
1	VDD	2	GND
3	VBIAS	4	GND
5	VREF	6	GND
7	PAEN	8	GND
9	SW0	10	GND
11	SW2	12	GND
13	SW1	14	GND

Table 6. Typical Test Conditions:

PIN	TX	RX	Description
VDD	3.3 V	3.3 V	Supply Voltage
VBIAS	3.3 V	3.3 V	Bias Supply
VREF	NA	NA	NOT USED
PAEN	2.9 V	0 V	PA Enable
SW0	0 V	2.9 V	Switch Control
SW2	2.9 V	0 V	Switch Control
SW1	NA	NA	NOT USED

Application Circuit

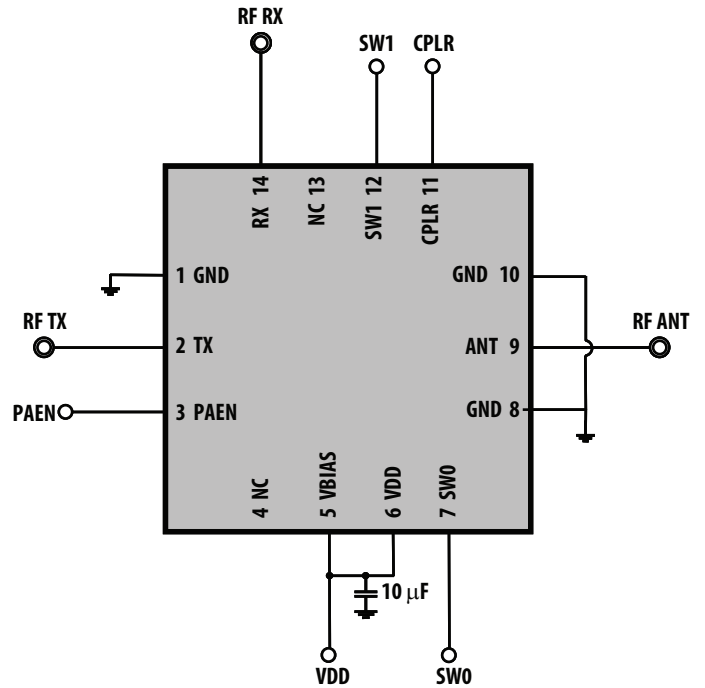

Note: Only one bypass cap on VDD is required

Demoboard Top Pins

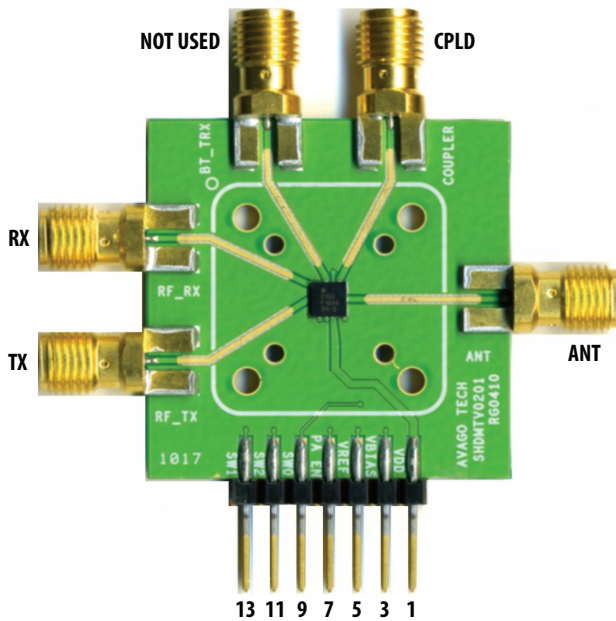

Demoboard Bottom Pins

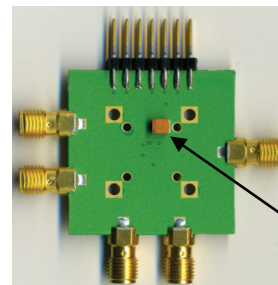

Note: Bottom pins 2, 4, 6, 8, 10, 12, and 14 are all grounded.

47 µF Cap

Ordering Information

Part Number	No. of Devices	Container
AFEM-S105-TR1G	3000	13" Reel
AFEM-S105-BLKG	100	Antistatic Bag

Marking Specification



Note: Package marking provides Orientation and Identification

- "5" = Device Code
- "F" = Manufacturing code
- "WW" = Build of Work Week
- "YY" = Build of Year
- "XXXX" = Last 4 Digits of Assembly Lot Number

Device Orientation & Pin 1 Location In Tape

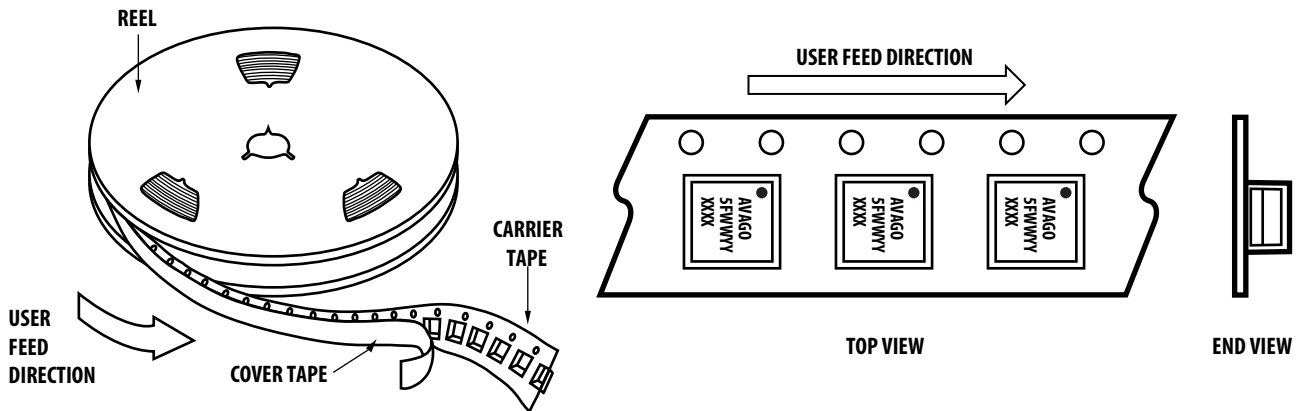

Tape Dimensions

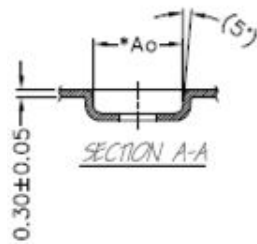
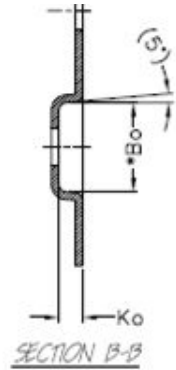
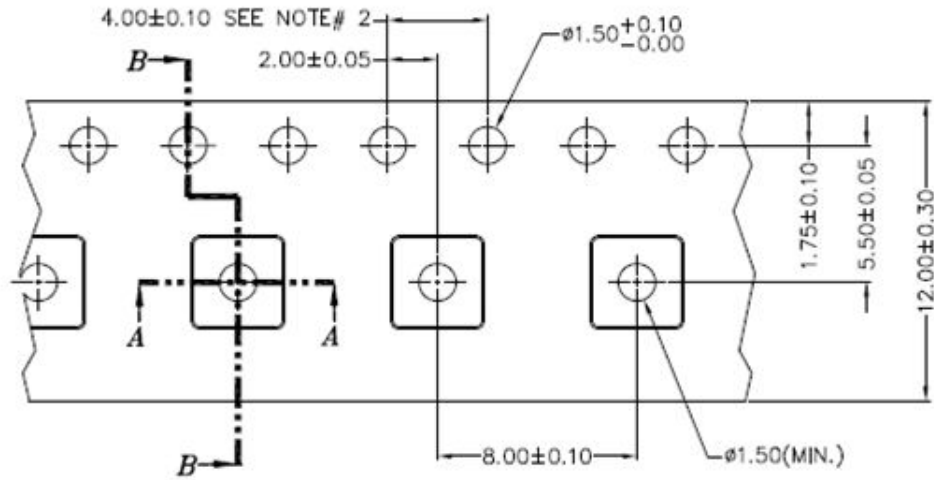

Ao:	3.60
Bo:	3.60
Ko:	0.95
Pitch:	8.00
Width:	12.00

Notes:

1. Ao & Bo measured at 0.3 mm above base of pocket.
2. 10 pitches cumulative tol. ±0.2 mm.
3. () Reference dimensions only.

Reel Dimensions (13 inch)

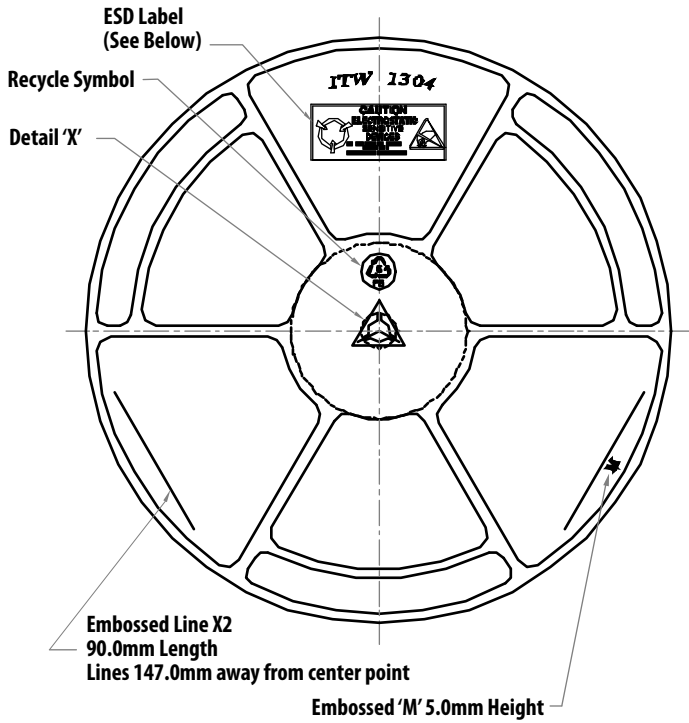

FRONT VIEW

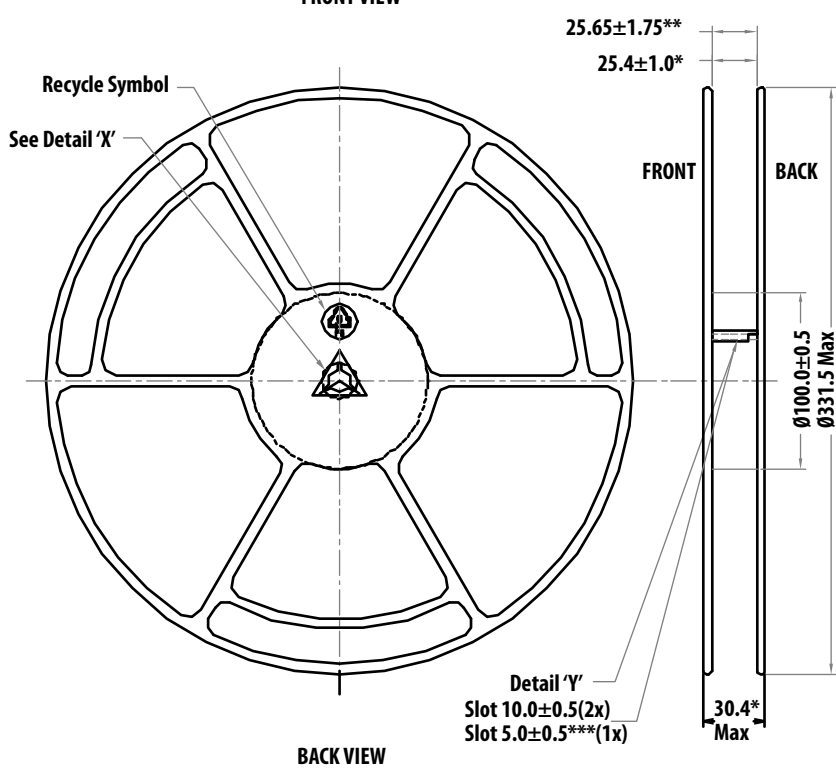

BACK VIEW

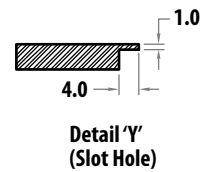
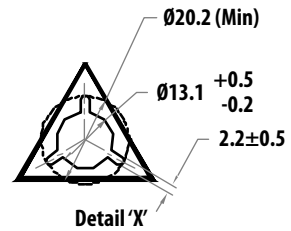

Reflow Profile Recommendations

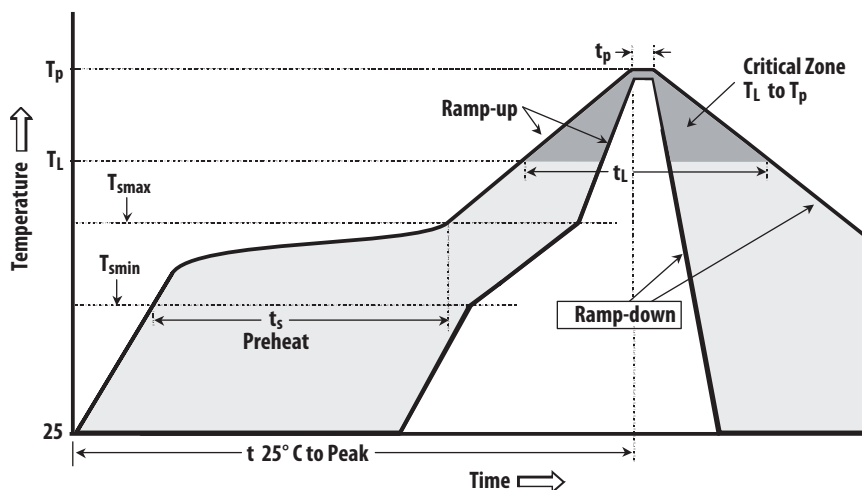

Typical SMT Reflow Profile for Maximum Temperature = $260 \pm 0/-5^\circ\text{C}$

Typical SMT Reflow Profile for Maximum Temperature = $260 \pm 0/-5^\circ\text{C}$

Profile Feature	Sn-Pb Solder	Pb-Free Solder
Average ramp-up rate (TL to TP)	3°C/sec max	3°C/sec max
Preheat		
– Temperature Min (T_{smin})	100° C	150° C
– Temperature Max (T_{smax})	150° C	200° C
– Time (min to max) (t_s)	60-120 sec	60-120 sec
T_{smax} to T_L		
– Ramp-up Rate		3°C/sec max
Time maintained above:		
– Temperature (T_L)	183° C	217° C
– Time (T_L)	60-150 sec	60-150 sec
Peak temperature (T_p)	240 $\pm 0/-5^\circ\text{C}$	260 $\pm 0/-5^\circ\text{C}$
Time within 5° C of actual Peak Temperature (t_p)	10-30 sec	20-40 sec
Ramp-down Rate	6°C/sec max	6°C/sec max
Time 25° C to Peak Temperature	6 min max.	8 min max.

For product information and a complete list of distributors, please go to our web site: www.avagotech.com

Avago, Avago Technologies, and the A logo are trademarks of Avago Technologies in the United States and other countries. Data subject to change. Copyright © 2005-2012 Avago Technologies. All rights reserved. AV02-3311EN - January 11, 2012

AVAGO
TECHNOLOGIES