



30N06

Power MOSFET

60V, 30A N-CHANNEL POWER MOSFET

■ DESCRIPTION

The UTC **30N06** is a low voltage power MOSFET and is designed to have better characteristics, such as fast switching time, low gate charge, low on-state resistance and excellent avalanche characteristics. This power MOSFET is usually used at automotive applications in power supplies, high efficient DC to DC converters and battery operated products.

■ FEATURES

- * $R_{DS(ON)} = 40m\Omega @ V_{GS} = 10V$
- * Ultra low gate charge (typical 20nC)
- * Low reverse transfer Capacitance ($C_{RSS} =$ typical 80 pF)
- * Fast switching capability
- * Avalanche energy specified
- * Improved dv/dt capability

■ SYMBOL

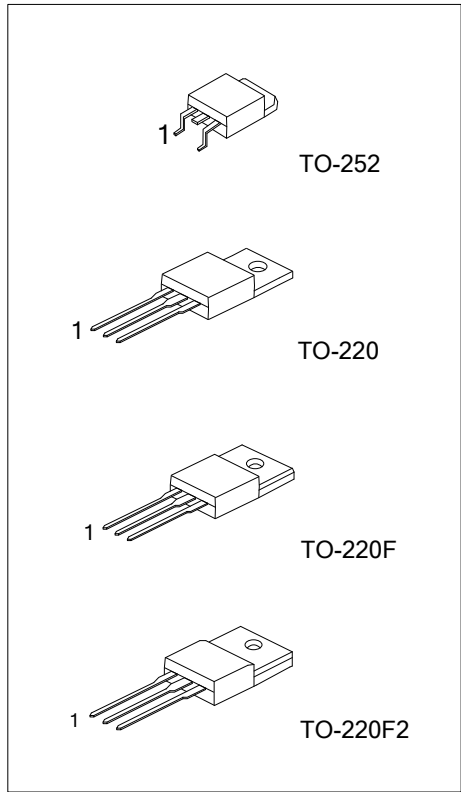
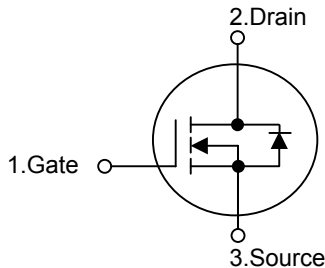

■ ORDERING INFORMATION

Ordering Number		Package	Pin Assignment			Packing
Lead Free	Halogen Free		1	2	3	
30N06L-TA3-T	30N06G-TA3-T	TO-220	G	D	S	Tube
30N06L-TF2-T	30N06G-TF2-T	TO-220F2	G	D	S	Tube
30N06L-TF3-T	30N06G-TF3-T	TO-220F	G	D	S	Tube
30N06L-TN3-T	30N06G-TN3-T	TO-252	G	D	S	Tape Reel

Note: Pin Assignment: G: Gate D: Drain S: Source

<p>30N06L-TA3-T</p> <p>(1)Packing Type (2)Package Type (3)Lead Free</p>	<p>(1) T: Tube, R: Tape Reel (2) TA3: TO-220, TF2: TO-220F2, TF3: TO-220F, TN3: TO-252 (3) G: Halogen Free, L: Lead Free</p>
---	--

■ ABSOLUTE MAXIMUM RATINGS($T_C = 25^\circ\text{C}$, unless otherwise specified)

PARAMETER		SYMBOL	RATINGS	UNIT
Drain-Source Voltage		V_{DSS}	60	V
Gate to Source Voltage		V_{GSS}	± 20	V
Continuous Drain Current	$T_C = 25^\circ\text{C}$	I_D	30	A
	$T_C = 100^\circ\text{C}$		21.3	A
Pulsed Drain Current (Note 2)		I_{DM}	120	A
Avalanche Energy	Single Pulsed (Note 3)	E_{AS}	300	mJ
	Repetitive (Note 2)	E_{AR}	8	mJ
Power Dissipation	TO-220	P_D	79	W
	TO-220F/ TO-220F2		45	
	TO-252		44	
Junction Temperature		T_J	+150	$^\circ\text{C}$
Operation Temperature		T_{OPR}	-55 ~ +150	$^\circ\text{C}$
Storage Temperature		T_{STG}	-55 ~ +150	$^\circ\text{C}$

Note: 1. Absolute maximum ratings are those values beyond which the device could be permanently damaged.

Absolute maximum ratings are stress ratings only and functional device operation is not implied.

2. Repeativity rating: pulse width limited by junction temperature

3. $L=0.66\text{mH}$, $I_{AS}=30\text{A}$, $V_{DD}=25\text{V}$, $R_G=20\Omega$, Starting $T_J=25^\circ\text{C}$

■ THERMAL DATA

PARAMETER		SYMBOL	RATING	UNIT
Junction to Ambient	TO-220	θ_{JA}	62	$^\circ\text{C/W}$
	TO-220F/TO-220F2		62.5	
	TO-252		110	
Junction to Case	TO-220	θ_{JC}	1.9	$^\circ\text{C/W}$
	TO-220F/TO-220F2		2.7	
	TO-252		2.85	

■ ELECTRICAL CHARACTERISTICS ($T_C = 25^\circ\text{C}$, unless otherwise specified)

PARAMETER	SYMBOL	TEST CONDITIONS	MIN	TYP	MAX	UNIT
OFF CHARACTERISTICS						
Drain-Source Breakdown Voltage	BV_{DSS}	$V_{GS} = 0\text{ V}, I_D = 250\ \mu\text{A}$	60			V
Drain-Source Leakage Current	I_{DSS}	$V_{DS} = 60\text{ V}, V_{GS} = 0\text{ V}$			10	μA
Gate-Source Leakage Current	Forward	I_{GSS}			100	nA
	Reverse				$V_{GS} = -20\text{ V}, V_{DS} = 0\text{ V}$	-100
Breakdown Voltage Temperature Coefficient	$\Delta BV_{DSS}/\Delta T_J$	$I_D = 250\ \mu\text{A}$, Referenced to 25°C		0.06		$\text{V}/^\circ\text{C}$
ON CHARACTERISTICS						
Gate Threshold Voltage	$V_{GS(TH)}$	$V_{DS} = V_{GS}, I_D = 250\ \mu\text{A}$	2.0		4.0	V
Static Drain-Source On-State Resistance	$R_{DS(ON)}$	$V_{GS} = 10\text{ V}, I_D = 15\text{ A}$		32	40	m Ω
DYNAMIC CHARACTERISTICS						
Input Capacitance	C_{ISS}	$V_{GS} = 0\text{ V}, V_{DS} = 25\text{ V},$ $f = 1\text{ MHz}$		800		pF
Output Capacitance	C_{OSS}			300		pF
Reverse Transfer Capacitance	C_{RSS}			80		pF
SWITCHING CHARACTERISTICS						
Turn-On Delay Time	$t_{D(ON)}$	$V_{DD} = 30\text{ V}, I_D = 15\text{ A}, V_{GS} = 10\text{ V}$ (Note 1, 2)		12		ns
Turn-On Rise Time	t_R			79		ns
Turn-Off Delay Time	$t_{D(OFF)}$			50		ns
Turn-Off Fall Time	t_F			52		ns
Total Gate Charge	Q_G	$V_{DS} = 60\text{ V}, V_{GS} = 10\text{ V},$ $I_D = 24\text{ A}$ (Note 1, 2)		20	30	nC
Gate-Source Charge	Q_{GS}			6		nC
Gate-Drain Charge	Q_{GD}			9		nC
SOURCE-DRAIN DIODE RATINGS AND CHARACTERISTICS						
Drain-Source Diode Forward Voltage	V_{SD}	$V_{GS} = 0\text{ V}, I_S = 30\text{ A}$			1.4	V
Maximum Continuous Drain-Source Diode Forward Current	I_S				30	A
Maximum Pulsed Drain-Source Diode Forward Current	I_{SM}				120	A

Notes: 1. Pulse Test : Pulse width $\leq 300\ \mu\text{s}$, Duty cycle $\leq 2\%$
 2. Essentially independent of operating temperature.

■ TEST CIRCUITS AND WAVEFORMS

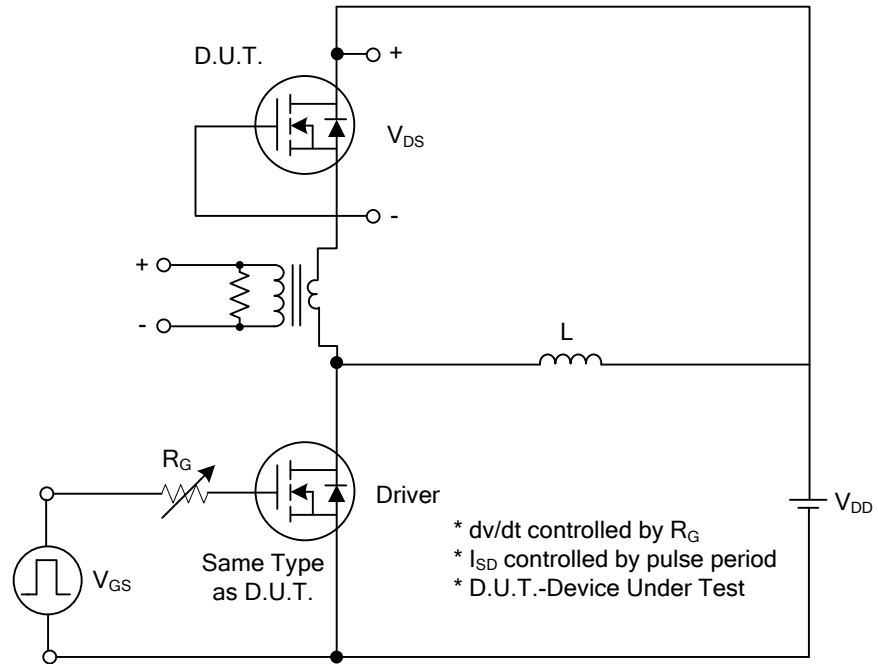

Peak Diode Recovery dv/dt Test Circuit

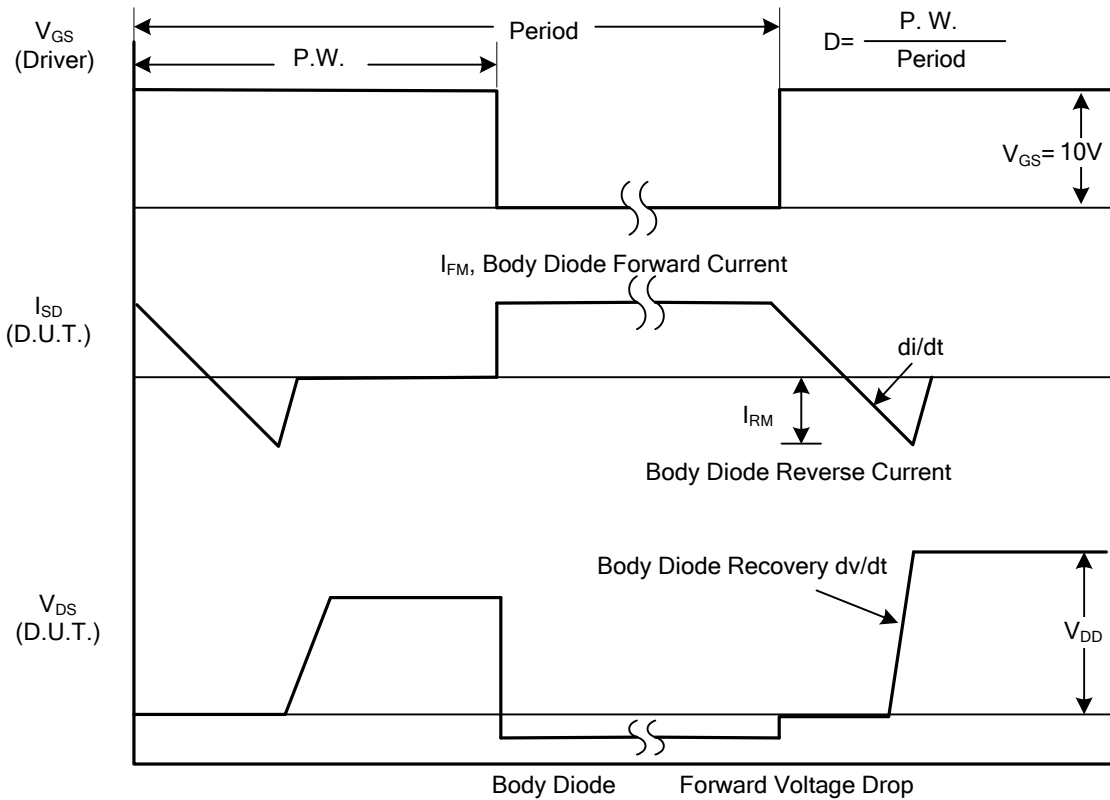

Peak Diode Recovery dv/dt Waveforms

TEST CIRCUITS AND WAVEFORMS (Cont.)

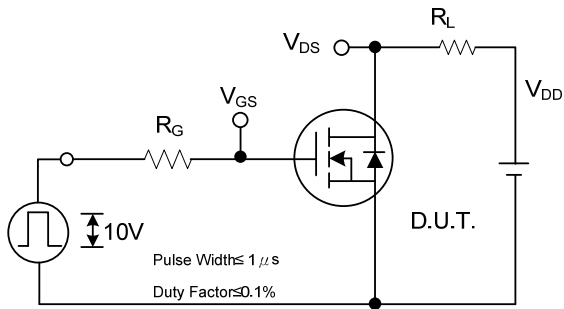

Switching Test Circuit

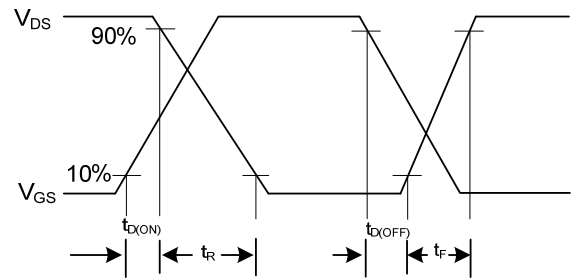

Switching Waveforms

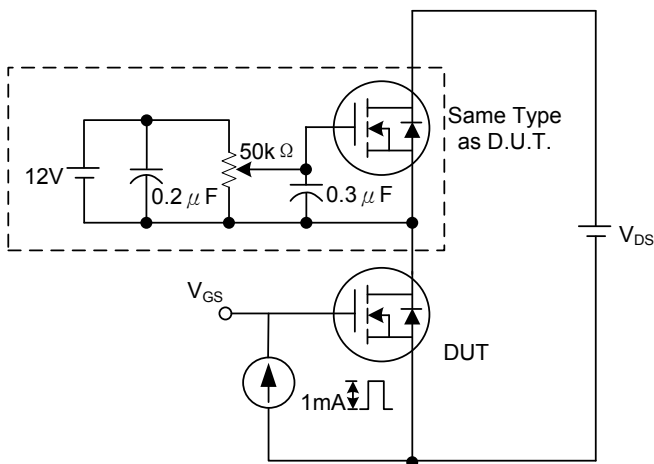

Gate Charge Test Circuit

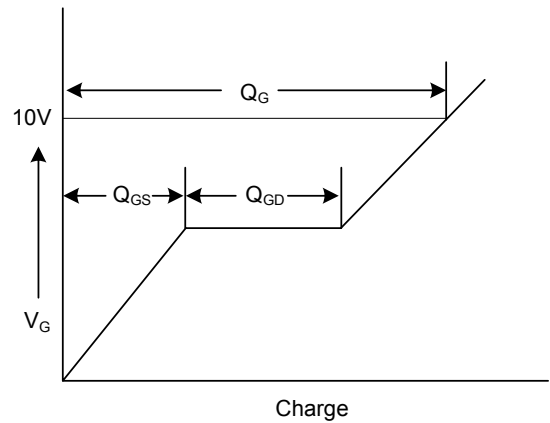

Gate Charge Waveform

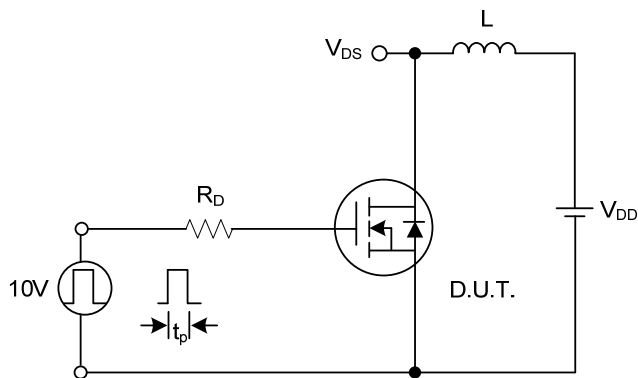

Unclamped Inductive Switching Test Circuit

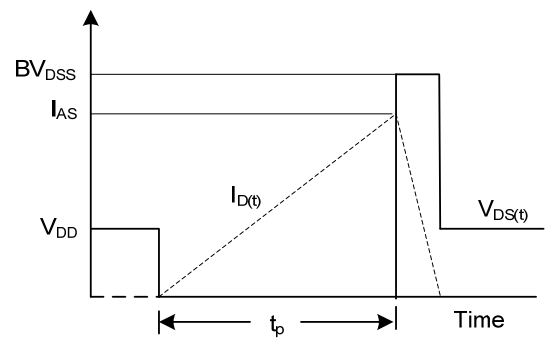

Unclamped Inductive Switching Waveforms

■ TYPICAL CHARACTERISTICS

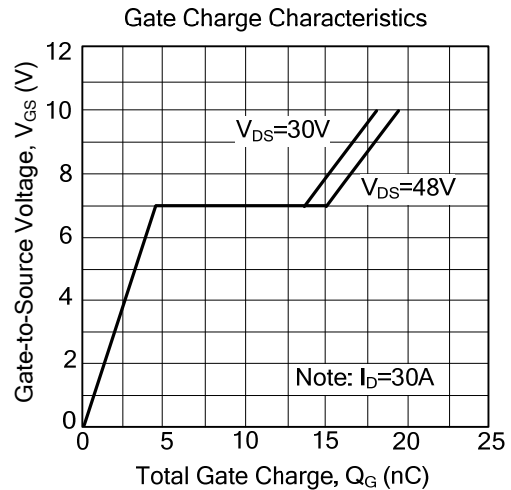
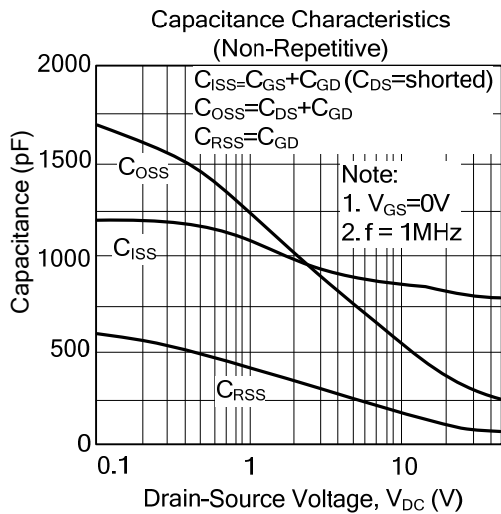
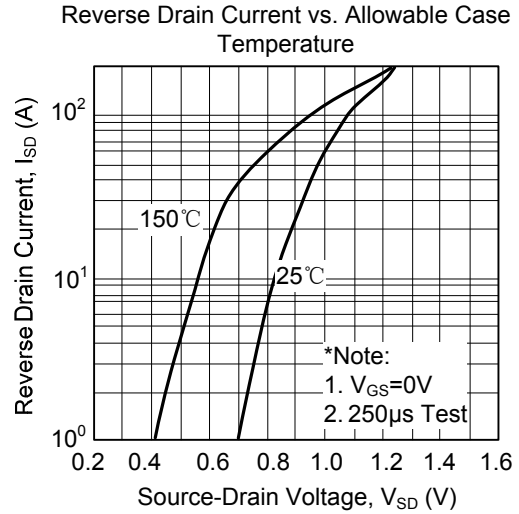
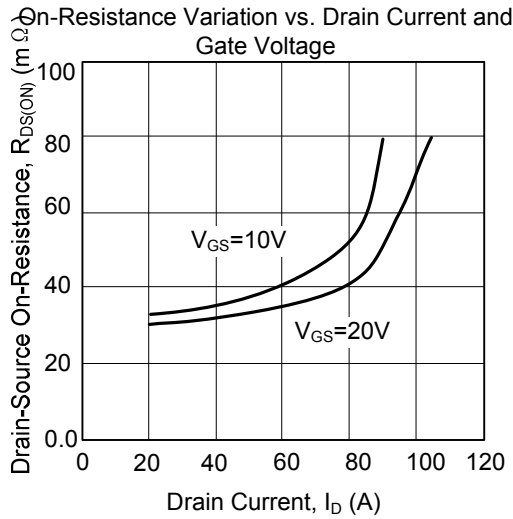
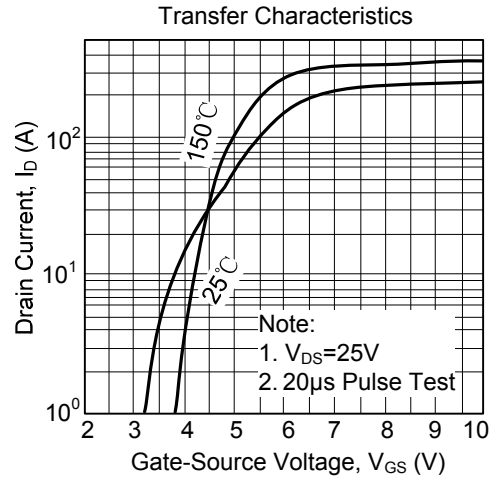
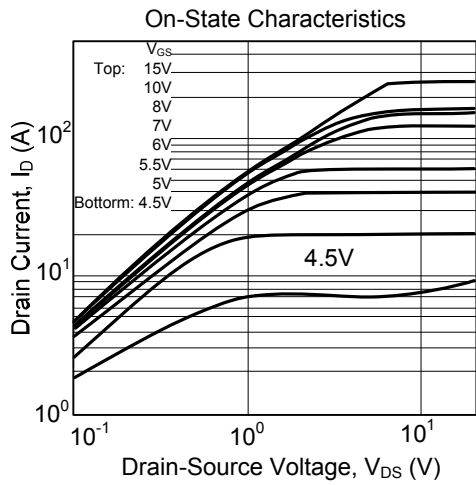

■ TYPICAL CHARACTERISTICS(Cont.)

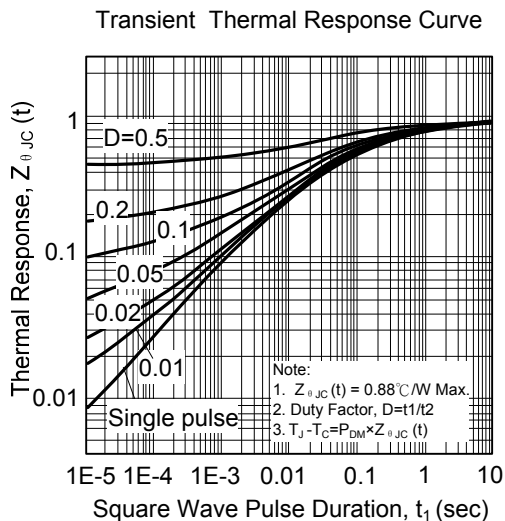
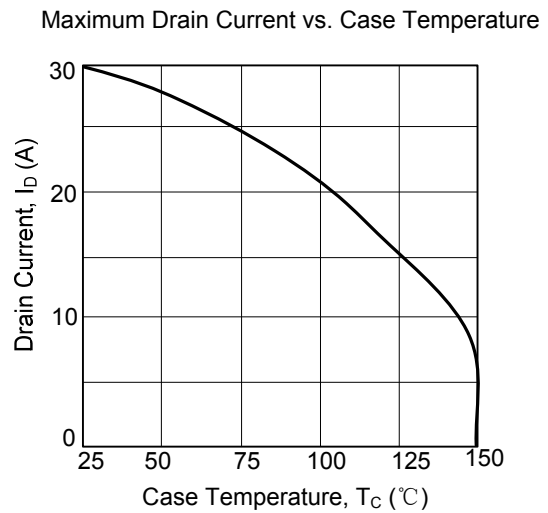
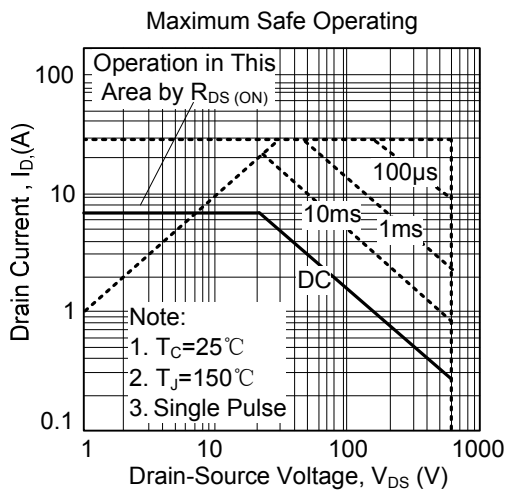
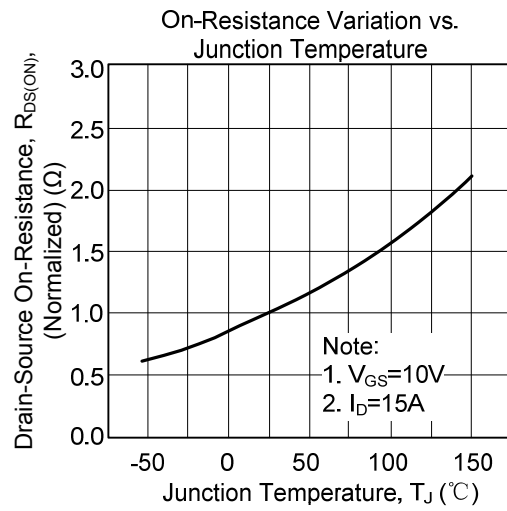
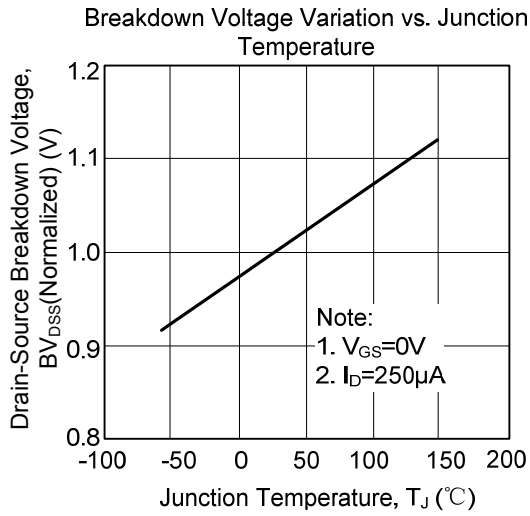

UTC assumes no responsibility for equipment failures that result from using products at values that exceed, even momentarily, rated values (such as maximum ratings, operating condition ranges, or other parameters) listed in products specifications of any and all UTC products described or contained herein. UTC products are not designed for use in life support appliances, devices or systems where malfunction of these products can be reasonably expected to result in personal injury. Reproduction in whole or in part is prohibited without the prior written consent of the copyright owner. The information presented in this document does not form part of any quotation or contract, is believed to be accurate and reliable and may be changed without notice.