

SOC Dual Channel 133MHz Pin Electronics Solution

ISL55164

The ISL55164 is a highly integrated System-on-a-Chip (SOC) pin electronics solution aimed at incorporating every analog function, along with some digital support functionality, required on a per channel basis for Automated Test Equipment. The interface, control and I/O of the chip are all digital; all analog circuitry is inside the chip. Two complete tester channels are integrated into each ISL55164.

The ISL55164 is pin and functionally compatible with Venus.

Features

- 133MHz
- 3.75ns Minimum Pulse Width
- Pin Electronics Driver/Comparator
 - 3 Level Driver (DVH/DVL/VTT)
 - 8V Driver Output Swings
 - 16V Comparator Input Voltage Range
 - Extremely Low HiZ Leakage over 16V Range
- Per Pin PMU
 - FV, FI, MV, MI
 - 8 Current Ranges (32mA, 8mA, 2mA, 512µA, 128µA, 32µA, 8µA, 2µA)
 - +12V Super Voltage Capability
 - Resistive Load (8 selectable resistor values)

- Deskew
 - Propagation Delay Adjustment (up to 12.8ns range)
 - Falling Edge Adjustment (up to ±3.2ns range)
 - Auto Calibration via PLL
- On-Chip DC Levels
 - 11 Levels/Pin
 - Gain and Offset /Level
 - DUT Ground Sensing/Pin
- 3-Bit Serial CPU Port
 - Load Internal Registers and Memory
 - Read Back Internal States
- Flexible High Speed Digital Inputs and Outputs
 - Selectable On-Chip Terminations for High Speed Inputs
 - 50Ω Series Terminated High Speed for Comparator Outputs
- Package/Power Dissipation
 - 64-Lead, 10mm x 10mm TQFP with Top Exposed Heat Slug
 - Pdq ≤ 1.10W/Channel; Pdc ≤ 2.2W/Chip

Applications

- Automated Test Equipment
- Instrumentation
- ASIC Verifiers

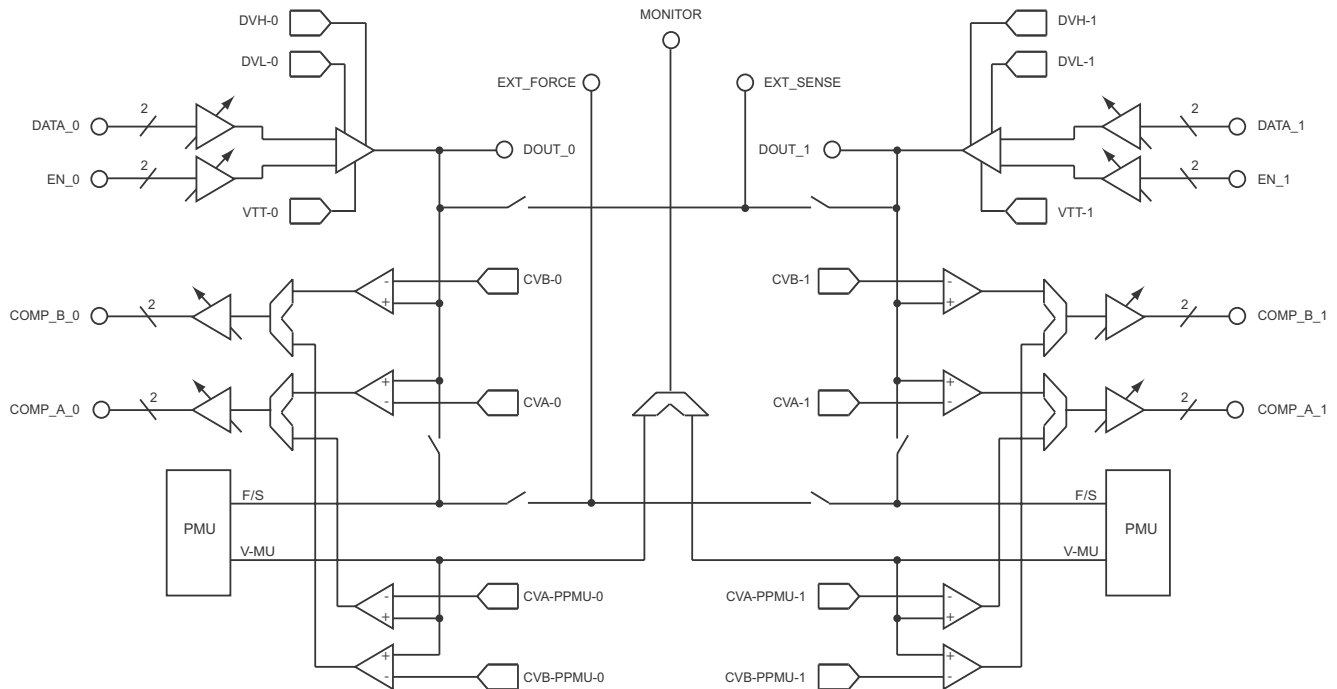

FIGURE 1. BLOCK DIAGRAM

For additional products, see www.intersil.com/product_tree

Intersil products are manufactured, assembled and tested utilizing ISO9000 quality systems as noted in the quality certifications found at www.intersil.com/design/quality

Intersil products are sold by description only. Intersil Corporation reserves the right to make changes in circuit design, software and/or specifications at any time without notice. Accordingly, the reader is cautioned to verify that data sheets are current before placing orders. Information furnished by Intersil is believed to be accurate and reliable. However, no responsibility is assumed by Intersil or its subsidiaries for its use; nor for any infringements of patents or other rights of third parties which may result from its use. No license is granted by implication or otherwise under any patent or patent rights of Intersil or its subsidiaries.

For information regarding Intersil Corporation and its products, see www.intersil.com