

6-Channel SD/ED/HD Video Filter with Charge Pump

ADA4424-6

FEATURES

- 3 SD channels; 18 MHz typical 1 dB bandwidth (BW)
- 3 ED/HD channels; 25 MHz/34 MHz typical 1 dB BW
- Fixed gain of 6.2 dB (2.042 V/V)
- On-board negative supply for output coupling without capacitors
- Minimal dc offset at the output pins
- Internal summation of Y and C channels for CVBS output
- Flexible input dc offset cancellation for luma channels
- D-terminal (EIAJ RC-5237 D5) and S-terminal (S1/S2) support
- Capable of driving 2 back-terminated 75 Ω video loads simultaneously
- Separate power-down pins for SD and ED/HD sections
- 38-lead TSSOP package
- Sony Green Partner Environmental Quality Approval Program compliant

APPLICATIONS

- DVD players and recorders
- Set-top boxes
- Projectors
- Personal video recorders

GENERAL DESCRIPTION

The ADA4424-6 is a high performance video reconstruction filter specifically designed for consumer applications. It consists of a standard definition (SD) section with two fifth-order Butterworth filters, and a high definition (HD) section with three fifth-order filters. The SD section contains an internal Y/C summer for CVBS output, whereas the HD section provides selectable corner frequencies for either extended definition (ED) or HD signals.

The ADA4424-6 filter/buffer section operates from a single 3.3 V supply. Full support for D-terminal (EIAJ RC-5237 D5) and S1/S2 signaling is provided, along with a dedicated 5 V supply pin. Separate enable pins are provided for the SD and HD sections.

FUNCTIONAL BLOCK DIAGRAM

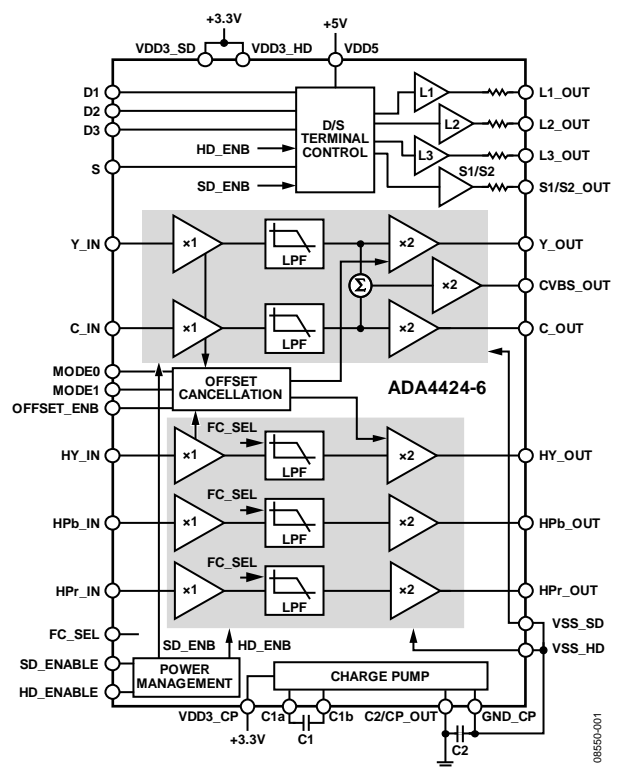

Figure 1.

The luma channels (Y_IN, HY_IN) of the ADA4424-6 are capable of detecting and cancelling dc input offsets of up to 1.1 V. Four distinct modes of detection/cancellation are available.

The output drivers on the ADA4424-6 feature rail-to-rail outputs with 6.2 dB gain. An on-board charge pump allows the outputs to swing up to 1.4 V below ground, eliminating the need for large coupling capacitors. Each output is capable of driving two 75 Ω doubly terminated cables.

The ADA4424-6 is available in a 38-lead TSSOP and operates in the extended industrial temperature range of -40°C to +85°C.

Rev. 0

Information furnished by Analog Devices is believed to be accurate and reliable. However, no responsibility is assumed by Analog Devices for its use, nor for any infringements of patents or other rights of third parties that may result from its use. Specifications subject to change without notice. No license is granted by implication or otherwise under any patent or patent rights of Analog Devices. Trademarks and registered trademarks are the property of their respective owners.

ADA4424-6**TABLE OF CONTENTS**

Features	1	Typical Performance Characteristics	8
Applications	1	Applications Information	10
Functional Block Diagram	1	CVBS Output	10
General Description	1	Corner Frequency Selection	10
Revision History	2	Input DC Offset Cancellation	10
Specifications	3	D-Terminal and S-Terminal Support	11
Absolute Maximum Ratings	5	Power-Down	12
Thermal Resistance	5	Charge Pump	12
Maximum Power Dissipation	5	Printed Circuit Board (PCB) Layout	12
ESD Caution	5	Outline Dimensions	14
Pin Configuration and Function Descriptions	6	Ordering Guide	14

REVISION HISTORY

10/09—Revision 0: Initial Version

SPECIFICATIONS

$V_{DD3} = 3.3\text{ V}$, $T_A = 25^\circ\text{C}$, $V_O = 2.042\text{ V p-p}$, $R_L = 150\ \Omega$, dc-coupled outputs, unless otherwise noted. Charge pump configured as shown in Figure 18.

Table 1.

Parameter	Test Conditions/Comments	Min	Typ	Max	Unit
OVERALL PERFORMANCE					
DC Voltage Gain	All channels	6.0	6.2	6.4	dB
Input Voltage Range, All Inputs	Not including dc offset		-0.6 to +1.4		V
Output Voltage Range, All Outputs			-1.6 to +3.0		V
Input Bias Current	Y_IN, HY_IN, dc-coupled		30		pA
Input Impedance	C_IN, HPb_IN, HPr_IN, ac-coupled		800		k Ω
SD CHANNEL DYNAMIC PERFORMANCE					
In-Band Peaking	$f = 100\text{ kHz to }6.75\text{ MHz}$		0.00	0.01	dB
1 dB Bandwidth		14	18		MHz
Out-of-Band Rejection	$f = 148.5\text{ MHz}$	38	42		dB
Crosstalk	$f = 1\text{ MHz}$		67		dB
Total Harmonic Distortion	$f = 1\text{ MHz}$, $V_O = 1.4\text{ V p-p}$		0.07		%
Signal-to-Noise Ratio	$f = 100\text{ kHz to }6\text{ MHz}$, unweighted		68		dB
Group Delay Variation	$f = 100\text{ kHz to }5\text{ MHz}$		1		ns
Differential Gain	NTSC		0.2		%
Differential Phase	NTSC		0.5		Degrees
ED CHANNEL DYNAMIC PERFORMANCE					
	FC_SEL = low (0)				
In-Band Peaking	$f = 100\text{ kHz to }13.5\text{ MHz}$		0.02	0.1	dB
1 dB Bandwidth		21	25		MHz
Out-of-Band Rejection	$f = 148.5\text{ MHz}$	38	42		dB
Crosstalk	$f = 1\text{ MHz}$		65		dB
Total Harmonic Distortion	$f = 5\text{ MHz}$, $V_O = 1.4\text{ V p-p}$		0.45		%
Signal-to-Noise Ratio	$f = 100\text{ kHz to }13.5\text{ MHz}$, unweighted		66		dB
Group Delay Variation	$f = 100\text{ kHz to }13.5\text{ MHz}$		1.5		ns
HD CHANNEL DYNAMIC PERFORMANCE					
	FC_SEL = high (1)				
In-Band peaking	$f = 100\text{ kHz to }30\text{ MHz}$		0.1	0.2	dB
1 dB bandwidth	Y Channel (HY_OUT) P Channels (HPb_OUT, HPr_OUT)	30	39		MHz
		25	34		MHz
Out-of-Band Rejection	$f = 148.5\text{ MHz}$	33	37		dB
Crosstalk	$f = 1\text{ MHz}$		65		dB
Total Harmonic Distortion	$f = 10\text{ MHz}$, $V_O = 1.4\text{ V p-p}$		1.2		%
Signal-to-Noise Ratio	$f = 100\text{ kHz to }30\text{ MHz}$, unweighted		65		dB
Group Delay Variation	$f = 100\text{ kHz to }30\text{ MHz}$		2.2		ns
DC CHARACTERISTICS					
Operating Voltage, 3.3 V Supply			3.14 to 3.46		V
Quiescent Supply Current, 3.3 V Supply	Both active, SD_ENABLE = high, HD_ENABLE = high, no load, no signal, not including D/S terminal outputs		93	133	mA
	SD disabled, SD_ENABLE = low, HD_ENABLE = high		54		mA
	HD disabled, SD_ENABLE = high, HD_ENABLE = low		45		mA
	Both disabled, SD_ENABLE = low, HD_ENABLE = low		6.1	10	mA
Operating Voltage, 5 V Supply			4.75 to 5.25		V
Quiescent Supply Current, 5 V Supply	SD_ENABLE = high, HD_ENABLE = high, $R_L = 100\text{ k}\Omega$, D1, D2, D3 = high, S = high		190	200	μA
	SD_ENABLE = low, HD_ENABLE = low		5	15	μA
PSRR	ED/HD channels, output referred		-42		dB
	SD channels, output referred		-41		dB

ADA4424-6

Parameter	Test Conditions/Comments	Min	Typ	Max	Unit
DC Offset	See Table 6 and Table 7				
Input Referred, Offset Cancellation Disabled Mode	OFFSET_ENB = low				
SD Channels	Y_IN = 0.0 V dc	-60	-20	+60	mV
CVBS Channel	Y_IN = 0.0 V dc	-100	-40	+100	mV
ED/HD Channels	HY_IN = 0.0 V dc	-60	-20	+60	mV
Input Referred, Fixed Offset Cancellation Mode	OFFSET_ENB = high, MODE1 = high				
SD Fixed High Offset Mode	Y_IN = 1.0 V dc, MODE0 = low	-100	-30	+100	mV
ED/HD Fixed High Offset Mode	HY_IN = 1.1 V dc, MODE0 = low	-100	-38	+100	mV
SD Fixed Low Offset Mode	Y_IN = 0.33 V dc, MODE0 = high	-90	-17	+90	mV
ED/HD Fixed Low Offset Mode	HY_IN = 0.33 V dc, MODE0 = high	-100	-25	+100	mV
Input Referred, Auto Offset Cancellation Mode	OFFSET_ENB = high, MODE1 = low				
SD Auto Offset Mode, Sync Tip Sampling	Y_IN = 0 V to 1.0 V dc, MODE0 = low	-70	-36	+70	mV
ED/HD Auto Offset Mode, Sync Tip Sampling	HY_IN = 0 V to 1.1 V dc, MODE0 = low	-95	-46	+95	mV
SD Auto Offset Mode, Back Porch Sampling	Y_IN = 0 V to 1.0 V dc, MODE0 = high	-25	-6	+25	mV
ED/HD Auto Offset Mode, Back Porch Sampling	HY_IN = 0 V to 1.1 V dc, MODE0 = high	-25	-5	+25	mV
ENABLE Assert Voltage			2		V
ENABLE Assert Time			95		ns
ENABLE Deassert Time			20		ns
ENABLE Input Bias Current	Disabled, xD_ENABLE = low		6.1		μA
Input-to-Output Isolation	Disabled, xD_ENABLE = low, f = 5 MHz		-100		dB
D-Terminal (L1_OUT, L2_OUT, L3_OUT) Low Level Output	V _{DD5} = 5.0 V, R _L = 100 kΩ, D1, D2, D3 = low		0.0		V
D-Terminal (L1_OUT, L3_OUT) Mid Level Output	V _{DD5} = 5.0 V, R _L = 100 kΩ, D1, D3 = open		2.1		V
D-Terminal (L1_OUT, L2_OUT, L3_OUT) High Level Output	V _{DD5} = 5.0 V, R _L = 100 kΩ, D1, D2, D3 = high		4.5		V
S-Terminal (S1/S2_OUT) Low Level Output	V _{DD5} = 5.0 V, R _L = 100 kΩ, S = low		0.0		V
S-Terminal (S1/S2_OUT) Mid Level Output	V _{DD5} = 5.0 V, R _L = 100 kΩ, S = open		2.1		V
S-Terminal (S1/S2_OUT) High Level Output	V _{DD5} = 5.0 V, R _L = 100 kΩ, S = high		4.5		V
CHARGE PUMP CHARACTERISTICS	All channels operating; C1 = C2 = 4.7 μF, C3 = C4 = 1.0 μF, R1 = 1 Ω (see Figure 18)				
Output Voltage			-1.66		V
Output Voltage Ripple			180		mV p-p
Output Ripple Frequency			100		kHz

ABSOLUTE MAXIMUM RATINGS

Table 2.

Parameter	Rating
3.3 V Supply Voltage	3.6 V
5 V Supply Voltage	5.5 V
Power Dissipation	See Figure 2
Storage Temperature Range	-65°C to +125°C
Operating Temperature Range	-40°C to +85°C
Lead Temperature (Soldering, 10 sec)	300°C
Junction Temperature	150°C

Stresses above those listed under Absolute Maximum Ratings may cause permanent damage to the device. This is a stress rating only; functional operation of the device at these or any other conditions above those indicated in the operational section of this specification is not implied. Exposure to absolute maximum rating conditions for extended periods may affect device reliability.

THERMAL RESISTANCE

θ_{JA} is specified for the device soldered to a high thermal conductivity 4-layer (2s2p) circuit board, as described in EIA/JESD 51-7.

Table 3.

Package Type	θ_{JA}	θ_{JC}	Unit
38-Lead TSSOP	67.6	14.0	°C/W

MAXIMUM POWER DISSIPATION

The maximum safe power dissipation in the ADA4424-6 package is limited by the associated rise in junction temperature (T_J) on the die. At approximately 150°C, which is the glass transition temperature, the plastic changes its properties. Even temporarily exceeding this temperature limit can change the stresses that the package exerts on the die, permanently shifting the parametric performance of the ADA4424-6. Exceeding a junction temperature of 150°C for an extended time can result in changes in the silicon devices, potentially causing failure.

The power dissipated in the package (P_D) is the sum of the quiescent power dissipation and the power dissipated in the package due to the load drive for all outputs. The quiescent power is the voltage between the supply pins (V_S) times the quiescent current (I_S). The power dissipated due to load drive depends on the particular application. For each output, the power due to load drive is calculated by multiplying the load current by the associated voltage drop across the device. The power dissipated due to the loads is equal to the sum of the power dissipations due to each individual load. RMS voltages and currents must be used in these calculations.

Airflow increases heat dissipation, effectively reducing θ_{JA} . Figure 2 shows the maximum power dissipation in the package vs. the ambient temperature for the 38-lead TSSOP (67.6°C/W) on a JEDEC standard 4-layer board. θ_{JA} values are approximate.

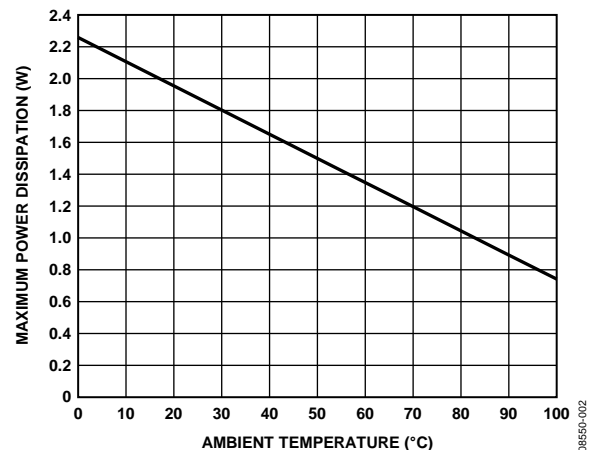

Figure 2. Maximum Power Dissipation vs. Ambient Temperature for a 4-Layer Board

ESD CAUTION



ESD (electrostatic discharge) sensitive device. Charged devices and circuit boards can discharge without detection. Although this product features patented or proprietary protection circuitry, damage may occur on devices subjected to high energy ESD. Therefore, proper ESD precautions should be taken to avoid performance degradation or loss of functionality.

ADA4424-6

PIN CONFIGURATION AND FUNCTION DESCRIPTIONS

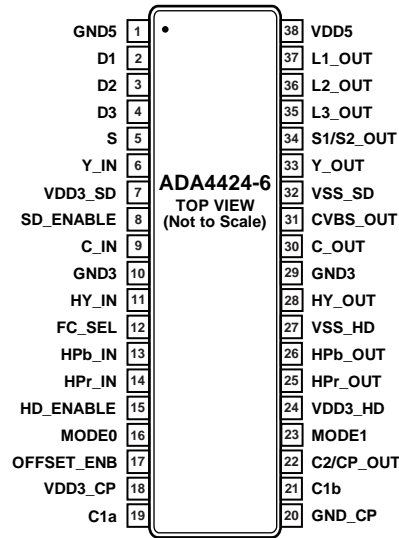

Figure 3. Pin Configuration, Top View

Table 4. Pin Function Descriptions

Pin No.	Mnemonic	Description
1	GND5	Ground Pin for 5 V Supply.
2	D1	D-Terminal Vertical Resolution Selection Input.
3	D2	D-Terminal Scan Selection Input.
4	D3	D-Terminal Aspect Ratio Selection Input.
5	S	S-Terminal Aspect Ratio Selection Input.
6	Y_IN	SD Luma (Y) Input.
7	VDD3_SD	3.3 V Supply Pin for SD Filter Section.
8	SD_ENABLE	Output Enable Pin for SD (Y, C, CVBS).
9	C_IN	SD Chroma (C) Input.
10, 29	GND3	Ground Pins for 3.3 V Supply.
11	HY_IN	ED/HD Y Component Input.
12	FC_SEL	Filter Corner Frequency Selection Pin for HY, HPb, HPr Channels.
13	HPb_IN	ED/HD Pb Component Input.
14	HPr_IN	ED/HD Pr Component Input.
15	HD_ENABLE	Output Enable Pin for ED/HD (HY, HPb, HPr).
16	MODE0	This pin selects sync tip or back porch sampling when MODE1 = 0, and selects high or low fixed offset subtraction when MODE1 = 1.
17	OFFSET_ENB	Offset Cancellation Enable Pin.
18	VDD3_CP	3.3 V Supply Pins for Charge Pump Section.
19, 21	C1a, C1b	Charge Pump Capacitor C1 Connection Pin.
20	GND_CP	Ground Pin for 3.3 V Charge Pump Supply.
22	C2/CP_OUT	Charge Pump Output Pin. Connect Capacitor C2 from this pin to ground.
23	MODE1	Selects Automatic or Fixed Offset Subtraction Mode.
24	VDD3_HD	3.3 V Supply Pin for ED/HD Filter Section.
25	HPr_OUT	ED/HD Pr Component Output.
26	HPb_OUT	ED/HD Pb Component Output.
27	VSS_HD	Negative Supply Pin for ED/HD Filter Section. This pin should be connected to the charge pump output (Pin 22), as shown in Figure 18.
28	HY_OUT	ED/HD Y Component Output.
30	C_OUT	SD Chroma (C) Output.
31	CVBS_OUT	SD Composite Video (CVBS) Output.

Pin No.	Mnemonic	Description
32	VSS_SD	Negative Supply Pin for SD Filter Section. This pin should be connected to the charge pump output (Pin 22), as shown in Figure 18.
33	Y_OUT	SD Luma (Y) Output.
34	S1/S2_OUT	S-Terminal Aspect Ratio Selection Output.
35	L3_OUT	D-Terminal Aspect Ratio Selection Output.
36	L2_OUT	D-Terminal Scan Selection Output.
37	L1_OUT	D-Terminal Vertical Resolution Selection Output.
38	VDD5	5 V Supply Pin for D-Terminal and S-Terminal Signaling.

ADA4424-6

TYPICAL PERFORMANCE CHARACTERISTICS

$V_{DD3} = 3.3\text{ V}$, $T_A = 25^\circ\text{C}$, $V_O = 2.042\text{ V p-p}$, $R_L = 150\ \Omega$, dc-coupled outputs, unless otherwise noted. Charge pump configured as shown in Figure 18.

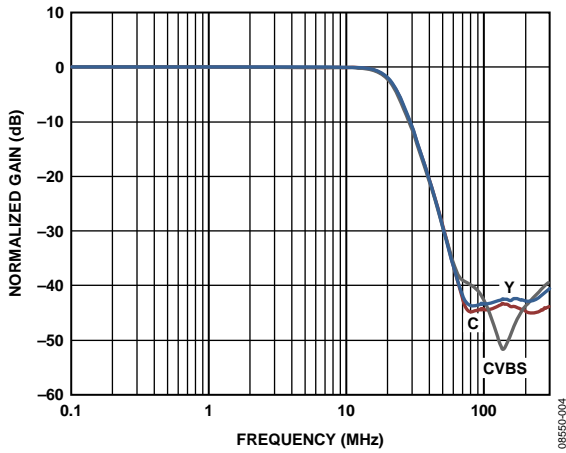

Figure 4. Frequency Response—SD Channels

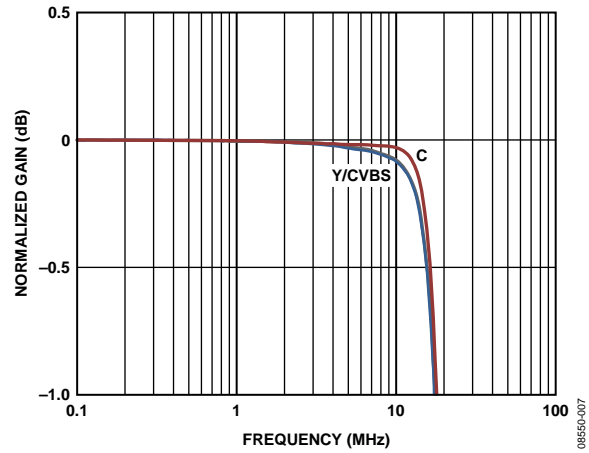

Figure 7. Frequency Response Peaking—SD Channels

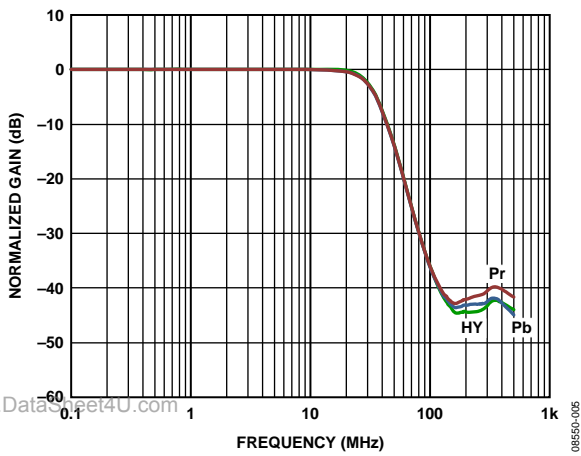

Figure 5. Frequency Response—ED Channels

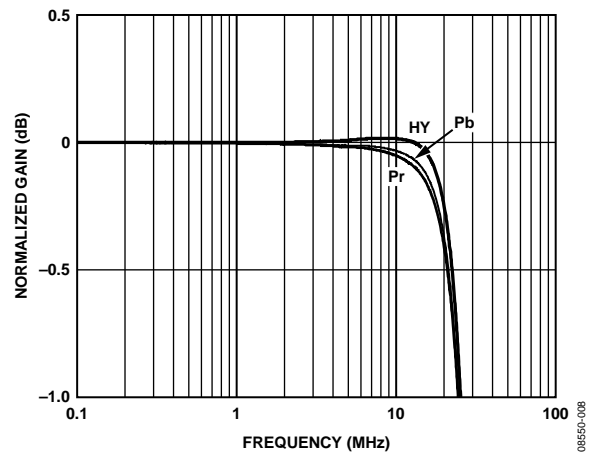

Figure 8. Frequency Response Peaking—ED Channels

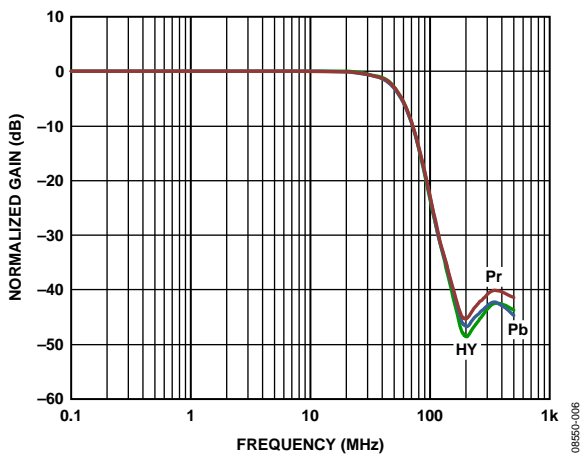

Figure 6. Frequency Response—HD Channels

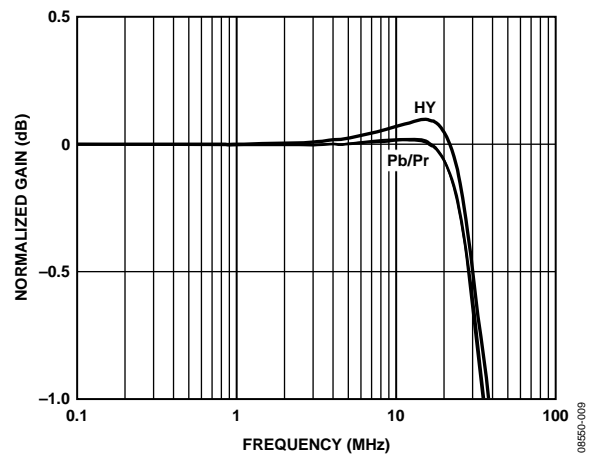

Figure 9. Frequency Response Peaking—HD Channels

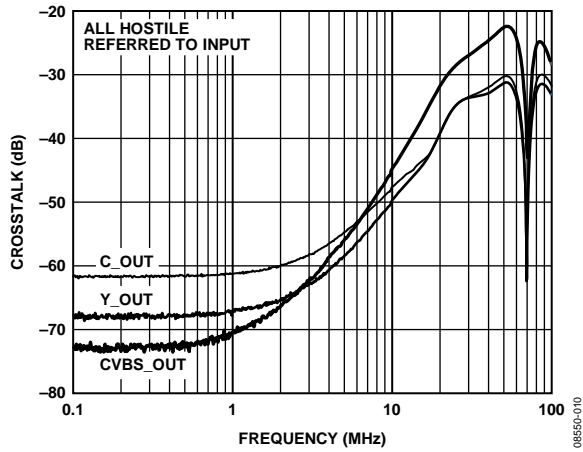

Figure 10. Crosstalk—SD Channels

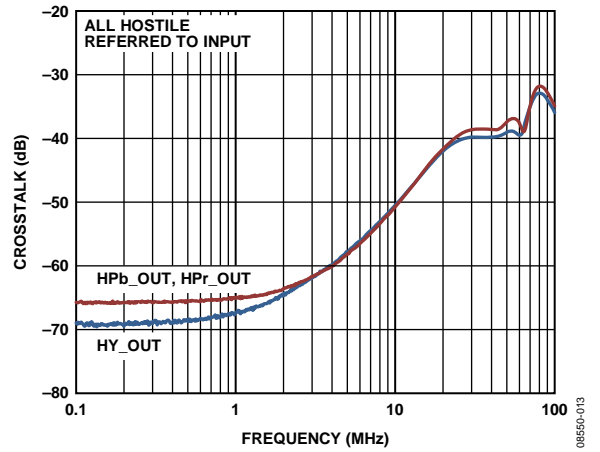

Figure 13. Crosstalk—ED and HD Channels

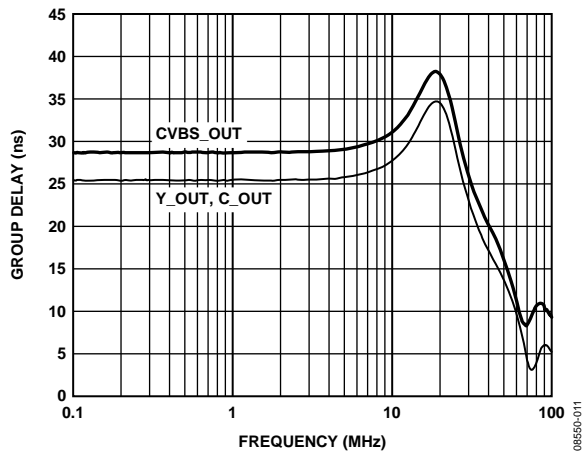

Figure 11. Group Delay—SD Channels

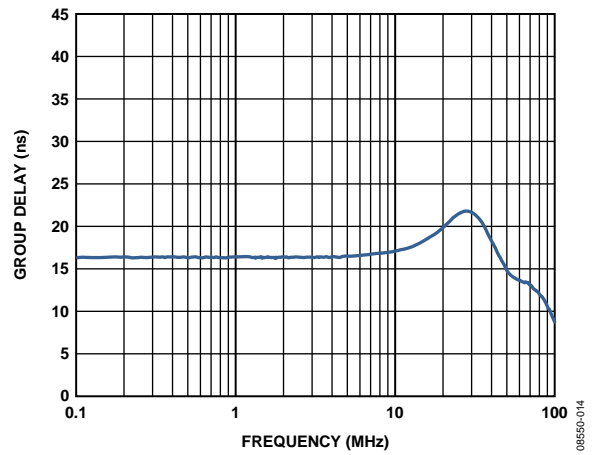

Figure 14. Group Delay—ED Channels

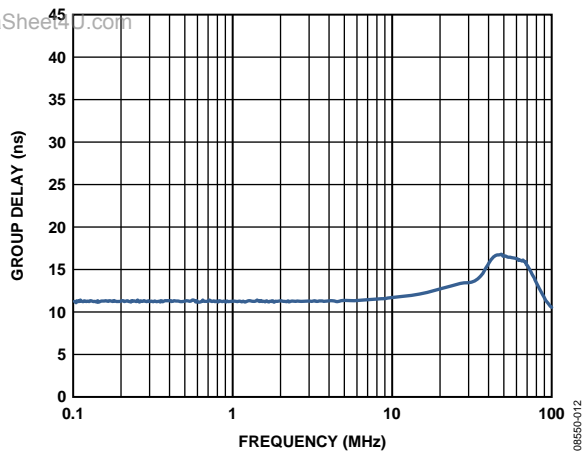

Figure 12. Group Delay—HD Channels

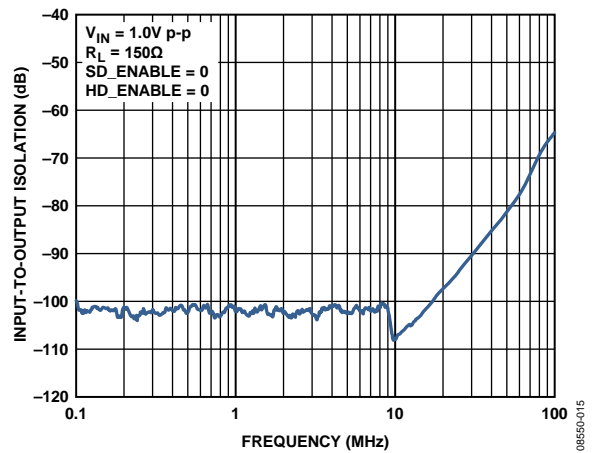

Figure 15. Input-to-Output Isolation—All Channels

ADA4424-6

APPLICATIONS INFORMATION

CVBS OUTPUT

The composite video signal (CVBS_OUT) is produced by passively summing the Y and C channels (see Figure 1), after amplification by their respective gain stages. Each signal experiences a 6.2 dB loss from the passive summation and is subsequently amplified by 6.2 dB in the fixed stage following the summer. The net signal gain through the composite video path is therefore 0 dB, and the resulting composite signal present at the ADA4424-6 output is the sum of Y and C with unity gain.

CORNER FREQUENCY SELECTION

The component channels of the ADA4424-6 allow for a 1 dB filter corner frequency of either 25 MHz or 39 MHz/34 MHz. The FC_SEL pin operates as described in Table 5.

Table 5. ED/HD Bandwidth Selection

FC_SEL (Pin 12)	HD/ED	-1 dB Corner Frequency (Typ)
Low (0)	ED	25 MHz
High-Z (Open)	HD	39 MHz (HY); 34 MHz (Pb, Pr)
High (1)	HD	39 MHz (HY); 34 MHz (Pb, Pr)

INPUT DC OFFSET CANCELLATION

The luma channels (Y_IN, HY_IN) of the ADA4424-6 are capable of detecting and cancelling dc input offsets of up to 1.1 V. Four distinct modes of detection/cancellation are available. These are selected via the MODE1 and MODE0 pins. The chroma (C_IN) and color difference (HPb_IN, HPr_IN) inputs do not support offset cancellation. It is recommended that these inputs be ac-coupled.

Automatic Detection/Cancellation Mode

There are two modes of automatic operation. The primary mode samples the input signal between the rising edge of the horizontal sync pulse and the start of active video (back porch), averages the value over the sampling interval, and subtracts it from the output signal. This is the more accurate method and is able to reduce the input-referred offsets to less than 25 mV.

An alternate method is available for copy-protected signals, where sampling the back porch may not provide a reliable dc average. This method detects the input negative sync tip, and clamps it to a fixed value (-214 mV for SD, and -300 mV for ED/HD). Sample intervals for SD and ED are shown in Figure 16, and the HD sample intervals are shown in Figure 17.

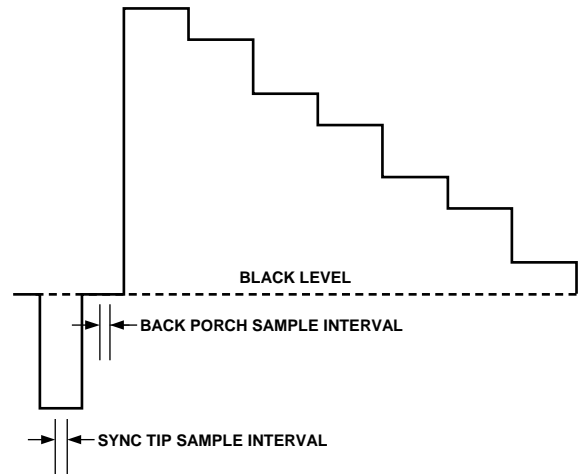

Figure 16. Back Porch and Sync Tip Sample Intervals (SD/ED)

08850-017

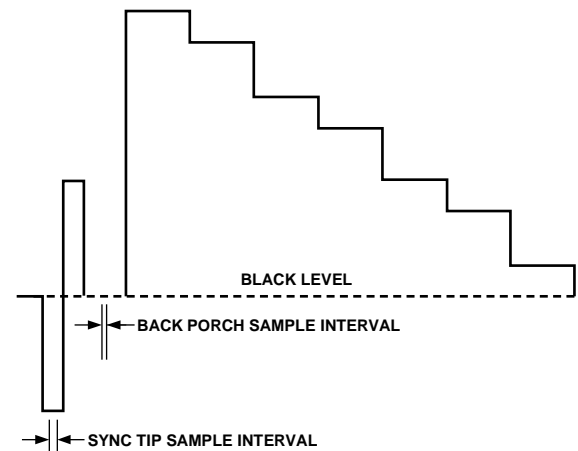

Figure 17. Back Porch and Sync Tip Sample Intervals (HD)

08850-018

Fixed Offset Cancellation Mode

In addition to the automatic mode, there are two levels of fixed offset correction available. In high offset mode, fixed voltages of 1.0 V and 1.1 V are subtracted from the Y_IN and HY_IN inputs, respectively. In low offset mode, a fixed voltage of 0.33 V is subtracted from both Y_IN and HY_IN. The various modes of offset cancellation are outlined in Table 6.

Table 6. Offset Cancellation Mode Selection

MODE1 (Pin 23)	MODE0 (Pin 16)	Output Offset Cancellation
Low (0)	Low (0)	Auto-cancel, sync-tip sampling mode. Clamps the input referred SD sync tip to -214 mV, and the input referred ED/HD sync tip to -300 mV.
Low (0)	High (1)	Auto-cancel, back porch sampling mode. Sets the output blanking level to 0 V, independent of sync depth.
High (1)	Low (0)	Fixed cancellation mode, high dc offset. Subtracts 1.0 V from the Y_IN signal; subtracts 1.1 V from the HY_IN signal.
High (1)	High (1)	Fixed cancellation mode, low dc offset. Subtracts 0.33 V from both the Y_IN and HY_IN signals.

Offset Cancellation Disable

The offset cancellation function can be enabled or disabled via the OFFSET_ENB pin, as described in Table 7.

Table 7. Offset Cancellation Enable/Disable

OFFSET_ENB (Pin 17)	Offset Cancellation State
Low (0)	Offset cancellation disabled.
High (1)	Offset cancellation is enabled. Function is determined by the MODE1 and MODE0 pins (see Table 6).

D-TERMINAL AND S-TERMINAL SUPPORT

Full D-terminal support (EIAJ RC-5237 D5) is provided for the component channels (HY_OUT, HPb_OUT, HPb_OUT). Level D1 through Level D5 are supported for vertical resolution, scan type, and aspect ratio selection. Details are shown in Table 8, Table 9, and Table 10.

S-terminal (also known as S_DC or S1/S2) support for S-video aspect ratio selection is also provided, as described in Table 11.

The VDD5 pin (Pin 38) provides 5 V power for these outputs. If D- or S-terminal support is not required, it is recommended that Pin 2 to Pin 5 and Pin 34 to Pin 38 remain unconnected.

Table 8. D-Terminal Control for Vertical Resolution Selection

Input Logic Level D1 (Pin 2)	Nominal Output (V) L1_OUT (Pin 37) $R_L = 100$ k Ω	Vertical Resolution (No. of Lines)
Low (0)	0.0	480
High-Z (Open)	2.1	720
High (1)	4.5	1080

Table 9. D-Terminal Control for Scan Selection

Input Logic Level D2 (Pin 3)	Nominal Output (V) L2_OUT (Pin 36) $R_L = 100$ k Ω	Scan Type
Low (0)	0.0	Interlaced
High-Z (Open)	2.1	N/A
High (1)	4.5	Progressive

Table 10. D-Terminal Control for Aspect Ratio Selection

Input Logic Level D3 (Pin 4)	Nominal Output (V) L3_OUT (Pin 35) $R_L = 100$ k Ω	Aspect Ratio
Low (0)	0.0	4:3
High-Z (Open)	2.1	4:3 letterbox
High (1)	4.5	16:9

Table 11. S-Terminal Control for Aspect Ratio Selection

Input Logic Level S (Pin 5)	Nominal Output (V) S1/S2_OUT (Pin 34) $R_L = 100$ k Ω	Aspect Ratio
Low (0)	0.0	4:3
High-Z (Open)	2.1	4:3 letterbox
High (1)	4.5	16:9

ADA4424-6

POWER-DOWN

The ADA4424-6 provides separate output enable pins for the SD and ED/HD sections. In addition to powering down the Y, C, and CVBS outputs, the SD_ENABLE pin, when driven low, also places the S1/S2 output (S1/S2_OUT, Pin 34) in a high impedance state. Likewise, driving the HD_ENABLE pin low disables the component outputs (HY_OUT, HPb_OUT, and HPr_OUT) and changes the L1, L2, and L3 outputs (Lx_OUT, Pin 35 to Pin 37) to a high impedance state. Control details are shown in Table 12 and Table 13.

Table 12. Power-Down Control for SD Channels

SD_ENABLE (Pin 8)	SD Outputs (Y, C, CVBS)	S1/S2_OUT (Pin 34)
Low (0)	Disabled	High-Z (Open)
High (1)	Enabled	Active
High-Z (Open)	Enabled	Active

Table 13. Power-Down Control for ED/HD Channels

HD_ENABLE (Pin 15)	ED/HD Outputs (HY, HPb, HPr)	Lx_OUT (Pin 35, Pin 36, Pin 37)
Low (0)	Disabled	High-Z (Open)
High (1)	Enabled	Active
High-Z (Open)	Enabled	Active

CHARGE PUMP

The ADA4424-6 features an on-chip charge pump that supplies a negative rail voltage for the output stages. To minimize internal noise coupling, the charge pump uses an external connection to the negative supply pins (VSS_SD and VSS_HD). These pins should be connected to the C2/CP_OUT pin, each decoupled with a 1.0 μ F capacitor. It is also recommended to place a small (1 Ω) series resistor in this connection. This forms a low-pass filter with the VSS decoupling capacitors, and further reduces coupled noise. The charge pump also requires two 4.7 μ F ceramic capacitors, one connected across the C1a and C1b pins, and one connected from the C2/CP_OUT pin to ground. The recommended charge pump configuration is shown in the application diagram (Figure 18).

With the black or zero level of the outputs placed at approximately ground potential, the outputs can swing up to 1.6 V in the negative direction. This eliminates the need for large output coupling capacitors because the input-referred dc offsets will not exceed ± 100 mV (depending on the selected cancellation mode).

PRINTED CIRCUIT BOARD (PCB) LAYOUT

As with all high speed applications, attention to the PCB layout is of paramount importance. When designing with the ADA4424-6, adhere to standard high speed layout practices. A solid ground plane is recommended, and surface-mount, ceramic power supply decoupling capacitors should be placed as close as possible to the supply pins. Connect all of the ADA4424-6 GND pins to the ground plane with traces that are as short as possible. Controlled impedance traces of the shortest length possible should be used to connect to the signal I/O pins and should not pass over any voids in the ground plane. A 75 Ω impedance level is typically used in video applications. When driving transmission lines, include series termination resistors on the signal outputs of the ADA4424-6.

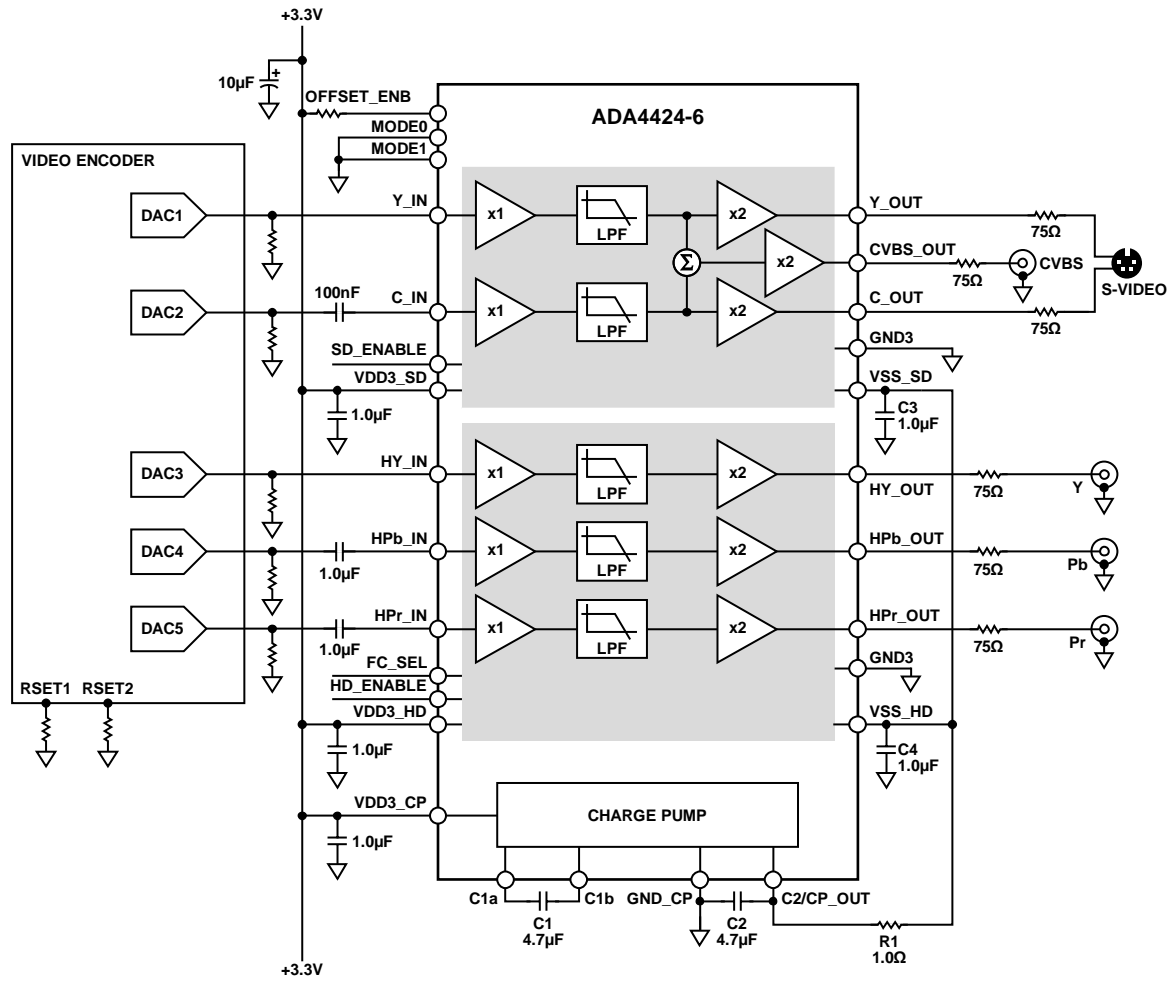
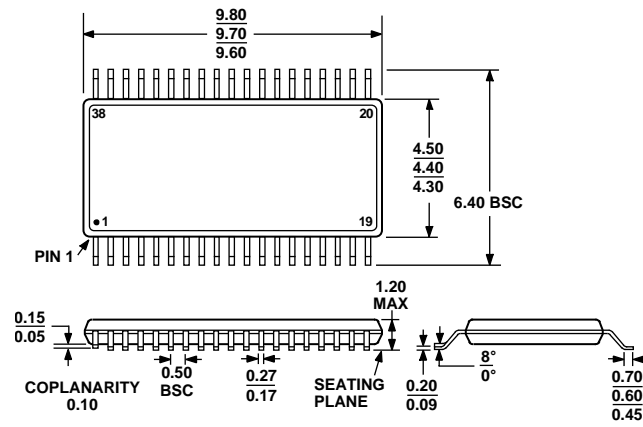

Figure 18. Typical Application Diagram for Using the ADA4424-6 in Auto Offset Cancellation Mode (D and S Terminal Connections Not Shown)

08550-019

ADA4424-6

OUTLINE DIMENSIONS



COMPLIANT TO JEDEC STANDARDS MO-153-BD-1

Figure 19. 38-Lead Thin Shrink Small Outline Package [TSSOP]
(RU-38)

Dimensions shown in millimeters

ORDERING GUIDE

Model	Temperature Range	Package Description	Package Option	Ordering Quantity
ADA4424-6ARUZ ¹	-40°C to +85°C	38-Lead Thin Shrink Small Outline Package (TSSOP)	RU-38	1
ADA4424-6ARUZ-R7 ¹	-40°C to +85°C	38-Lead Thin Shrink Small Outline Package (TSSOP)	RU-38	1,000
ADA4424-6ARUZ-RL ¹	-40°C to +85°C	38-Lead Thin Shrink Small Outline Package (TSSOP)	RU-38	1,500

¹ Z = RoHS Compliant Part.

NOTES

ADA4424-6

NOTES

www.DataSheet4U.com