

## Aerospace 2 x 20 A - 100 V Schottky rectifier

### Features

- Forward current: 2 x 20 A
- Repetitive peak voltage: 100 V
- Low forward voltage drop: 0.9 V
- Maximum junction temperature: 175 °C
- Negligible switching losses
- Low capacitance
- High reverse avalanche surge capability
- Hermetic packages
- Target radiation qualification:
  - 150 krad (Si) low dose rate
  - 1 Mrad high dose rate
- ESCC qualified



### Description

This power Schottky rectifier is designed and packaged to comply with the ESCC5000 specification for aerospace products. Housed in hermetically sealed packages both surface mount and through hole, it is ideal for use in applications for aerospace and other harsh environments.

The STPS40100HR is intended for use in medium voltage application and particularly, in high frequency circuits where low switching losses and low noise are required.

**Table 1. Device summary**

Order code	ESCC detailed specification	Quality level	Configuration	Package	Mass	EPPL
STPS40100C2FSY1	-	Engineering model	Double die, common cathode pin 2	TO-254	10.0 g	-
STPS40100C2FSYHR	5106/019/01	ESCC flight				Y

# 1 Characteristics

**Table 2. Absolute maximum ratings**

Symbol	Characteristic	Value	Unit
$I_{FSM}$	Forward surge current (per diode) <sup>(1)</sup>	300	A
$V_{RRM}$	Repetitive peak reverse voltage <sup>(2)</sup>	100	V
$I_{RRM}$	Repetitive peak reverse current <sup>(3)</sup>	1	A
$I_O$	Average output rectified current (50% duty cycle): <sup>(4), (5)</sup> per diode per device	20	A
		40	
$I_{F(RMS)}$	Forward rms current (per diode)	30	A
$T_{OP}$	Operating temperature range <sup>(6)</sup> (case temperature)	-65 to +175	°C
$T_J$	Junction temperature	+175	°C
$T_{STG}$	Storage temperature range <sup>(6)</sup>	-65 to +175	°C
$T_{SOL}$	Soldering temperature: For TO-254 <sup>(7)</sup>	+260	°C
dV/dt	Critical rate of rise of reverse voltage	10000	V/μs

1. Sinusoidal pulse of 10 ms duration
2. Pulsed, duration 5 ms, F = 50 Hz
3. Pulsed, duration 2 μs, F = 1 kHz
4. For  $T_{case} \geq +132^\circ\text{C}$  per device and  $T_{case} \geq +148^\circ\text{C}$  per diode, derate linearly to 0 A at +175°C.
5. The "per device" ratings apply only when both anode terminals are tied together.
6. For devices with hot solder dip lead finish all testing performed at  $T_{amb} > +125^\circ\text{C}$  are carried out in a 100% inert atmosphere.
7. Duration 10 seconds maximum at a distance of not less than 1.5 mm from the device body and the same lead shall not be resoldered until 3 minutes have elapsed.

**Table 3. Thermal resistance**

Symbol	Characteristic	Value	Unit
$R_{th(j-c)}$ <sup>(1)</sup>	Thermal resistance, junction to case per diode	1.5	°C/W
	per device	1.2	

1. Package mounted on infinite heatsink

**Table 4. Electrical measurements at ambient temperature (per diode),  $T_{amb} = 22 \pm 3 \text{ }^\circ\text{C}$** 

Symbol	Characteristic	MIL-STD-750 test method	Test conditions	Values		Units
				Min.	Max.	
$I_{R1}$	Reverse current	4016	DC method, $V_R = 100 \text{ V}$	-	30	$\mu\text{A}$
$I_{R2}$			DC method, $V_R = 50 \text{ V}$	-	5	$\mu\text{A}$
$V_{F1}^{(1)}$	Forward voltage	4011	Pulse method, $I_F = 5 \text{ A}$	-	610	mV
$V_{F2}^{(1)}$			Pulse method, $I_F = 10 \text{ A}$	-	730	mV
$V_{F3}^{(1)}$			Pulse method, $I_F = 20 \text{ A}$	-	900	mV
C	Capacitance	4001	$V_R = 10 \text{ V}$ , $F = 1 \text{ MHz}$	-	1	nF
$Z_{th(j-c)}^{(2)}$	Relative thermal impedance, junction to case	3101	$I_H = 15 \text{ to } 40 \text{ A}$ , $t_H = 50 \text{ ms}$ $I_M = 50 \text{ mA}$ , $t_{md} = 100 \mu\text{s}$	Calculate $\Delta V_F^{(3)}$		$^\circ\text{C/W}$

1. Pulse width  $\leq 300\mu\text{s}$ , duty cycle  $\leq 2\%$
2. Performed only during screening tests parameter drift values (initial measurements for HTRB), go-no-go.
3. The limits for  $\Delta V_F$  shall be defined by the manufacturer on every lot in accordance with MIL-STD-750 Method 3101 and shall guarantee the  $R_{th(j-c)}$  limits specified in maximum ratings.

**Table 5. Electrical measurements at high and low temperatures (per diode)**

Symbol	Characteristic	MIL-STD-750 test method	Test conditions <sup>(1)</sup>	Values		Units
				Min.	Max.	
$I_{R1}$	Reverse current	4016	$T_{case} = +125 (+0, -5) \text{ }^\circ\text{C}$ DC method, $V_R = 100 \text{ V}$	-	20	mA
$I_{R2}$			$T_{case} = +125 (+0, -5) \text{ }^\circ\text{C}$ DC method, $V_R = 50 \text{ V}$	-	7.5	mA
$V_{F2}^{(2)}$	Forward voltage	4011	$T_{case} = +125 (+0, -5) \text{ }^\circ\text{C}$ pulse method, $I_F = 10 \text{ A}$	-	660	mV
$V_{F3}^{(2)}$			$T_{case} = +125 (+0, -5) \text{ }^\circ\text{C}$ pulse method, $I_F = 20 \text{ A}$	-	850	mV
			$T_{case} = -55 (+5, -0) \text{ }^\circ\text{C}$ pulse method, $I_F = 20 \text{ A}$	-	950	mV

1. Read and record measurements shall be performed on a sample of 5 components with 0 failures allowed. Alternatively a 100% inspection may be performed.
2. Pulse width  $\leq 300\mu\text{s}$ , duty cycle  $\leq 2\%$

## 2 Configurations

Figure 1. Available device configuration

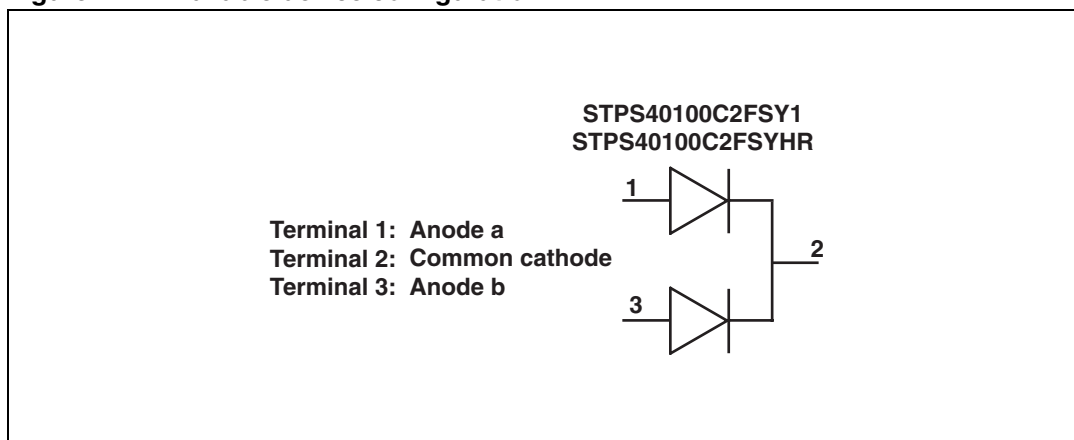

### 3 Package Information

In order to meet environmental requirements, ST offers these devices in different grades of ECOPACK<sup>®</sup> packages, depending on their level of environmental compliance. ECOPACK<sup>®</sup> specifications, grade definitions and product status are available at: [www.st.com](http://www.st.com). ECOPACK<sup>®</sup> is an ST trademark.

**Figure 2. Metal flange mount package (TO-254<sup>(a)</sup>), 3 lead dimension definitions**

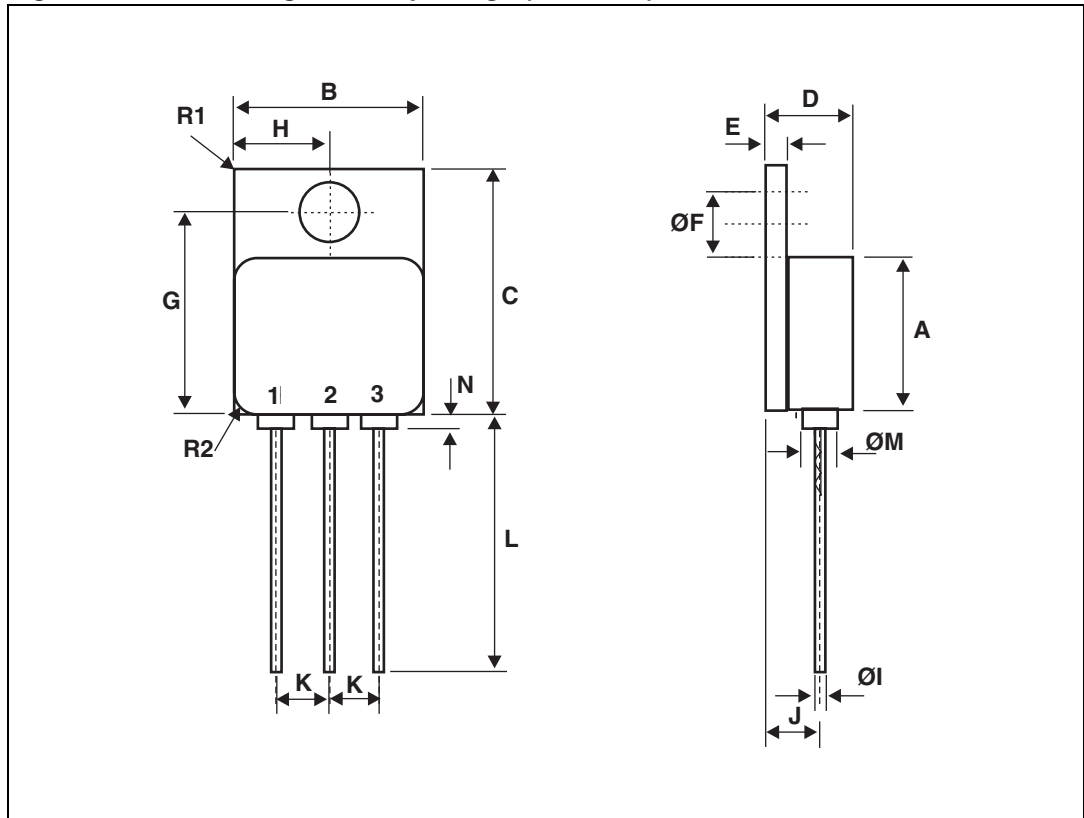

a. The terminal identification is specified by the device configuration. See [Figure 1](#) for terminal connections

**Table 6. Metal flange mount package (TO-254), 3-lead dimension values**

Reference	Dimension in millimetres		Dimlension in inches	
	Min.	Max.	Min.	Max.
A	13.59	13.84	0.535	0.545
B	13.59	13.84	0.535	0.545
C	20.07	20.32	0.790	0.800
D	6.3	6.7	0.248	0.264
E	1	3.9	0.039	0.154
ØF	3.5	3.9	0.138	0.154
G	16.89	17.4	0.665	0.685
H	6.86 BSC		0.270 BSC	
ØI <sup>(1)</sup>	0.89	1.14	0.035	0.045
J	3.81 BSC		0.150 BSC	
K	3.81 BSC		0.150 BSC	
L	12.95	14.5	0.510	0.571
ØM	3.05 Typ.		0.120 Typ.	
N	-	0.71	-	0.028
R1 <sup>(2)</sup>	-	1	-	0.039
R2 <sup>(3)</sup>	1.65 Typ.		0.065	

1. 3 locations
2. Radius of heatsink flange corner - 4 locations
3. Radius of body corner - 4 locations

## 4 Ordering Information

Table 7. Ordering information

Order code	ESCC detailed specification	Package	Lead finish	Marking	EPPL	Mass (g)	Packing
STPS40100C2FSY1	-	TO-254	Gold	STPS40100C2FSY1 + BeO	-	10.0	Strip pack
STPS40100C2FSYHR	5106/019/01		Solder dip	510601901 + BeO	Y		

## 5 Revision history

**Table 8. Document revision history**

Date	Revision	Changes
26-Mar-2010	1	Initial release.



**Please Read Carefully:**

Information in this document is provided solely in connection with ST products. STMicroelectronics NV and its subsidiaries ("ST") reserve the right to make changes, corrections, modifications or improvements, to this document, and the products and services described herein at any time, without notice.

All ST products are sold pursuant to ST's terms and conditions of sale.

Purchasers are solely responsible for the choice, selection and use of the ST products and services described herein, and ST assumes no liability whatsoever relating to the choice, selection or use of the ST products and services described herein.

No license, express or implied, by estoppel or otherwise, to any intellectual property rights is granted under this document. If any part of this document refers to any third party products or services it shall not be deemed a license grant by ST for the use of such third party products or services, or any intellectual property contained therein or considered as a warranty covering the use in any manner whatsoever of such third party products or services or any intellectual property contained therein.

**UNLESS OTHERWISE SET FORTH IN ST'S TERMS AND CONDITIONS OF SALE ST DISCLAIMS ANY EXPRESS OR IMPLIED WARRANTY WITH RESPECT TO THE USE AND/OR SALE OF ST PRODUCTS INCLUDING WITHOUT LIMITATION IMPLIED WARRANTIES OF MERCHANTABILITY, FITNESS FOR A PARTICULAR PURPOSE (AND THEIR EQUIVALENTS UNDER THE LAWS OF ANY JURISDICTION), OR INFRINGEMENT OF ANY PATENT, COPYRIGHT OR OTHER INTELLECTUAL PROPERTY RIGHT.**

**UNLESS EXPRESSLY APPROVED IN WRITING BY AN AUTHORIZED ST REPRESENTATIVE, ST PRODUCTS ARE NOT RECOMMENDED, AUTHORIZED OR WARRANTED FOR USE IN MILITARY, AIR CRAFT, SPACE, LIFE SAVING, OR LIFE SUSTAINING APPLICATIONS, NOR IN PRODUCTS OR SYSTEMS WHERE FAILURE OR MALFUNCTION MAY RESULT IN PERSONAL INJURY, DEATH, OR SEVERE PROPERTY OR ENVIRONMENTAL DAMAGE. ST PRODUCTS WHICH ARE NOT SPECIFIED AS "AUTOMOTIVE GRADE" MAY ONLY BE USED IN AUTOMOTIVE APPLICATIONS AT USER'S OWN RISK.**

Resale of ST products with provisions different from the statements and/or technical features set forth in this document shall immediately void any warranty granted by ST for the ST product or service described herein and shall not create or extend in any manner whatsoever, any liability of ST.

ST and the ST logo are trademarks or registered trademarks of ST in various countries.

Information in this document supersedes and replaces all information previously supplied.

The ST logo is a registered trademark of STMicroelectronics. All other names are the property of their respective owners.

© 2010 STMicroelectronics - All rights reserved

STMicroelectronics group of companies

Australia - Belgium - Brazil - Canada - China - Czech Republic - Finland - France - Germany - Hong Kong - India - Israel - Italy - Japan - Malaysia - Malta - Morocco - Philippines - Singapore - Spain - Sweden - Switzerland - United Kingdom - United States of America

[www.st.com](http://www.st.com)