

TaNFilm® Resistor Network Precision Moulded DIP

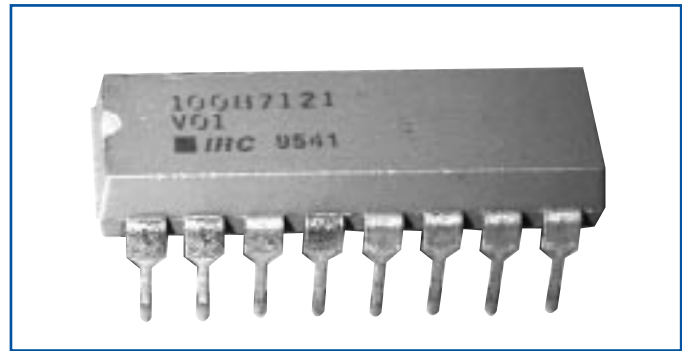

M900 SERIES

- **Absolute tolerance to $\pm 0.05\%$**
- **Absolute TCR to ± 15 ppm/ $^{\circ}\text{C}$**
- **Superior TCR tracking to ± 5 ppm/ $^{\circ}\text{C}$**
- **Ratios available to 0.05%**
- **Custom circuit schematics available**



Electrical Data

			M954	M987	M998	M959	M989	M999
Power rating at 70°C	Resistor	watts	0.1	0.1	0.1	0.2	0.2	0.2
	Network		0.7	1.3	1.0	0.8	1.4	1.6
Resistance ranges		ohms	10R to 200K			10R to 400K		
Standard resistance ratio and tolerance		$\pm\%$	0.1, 0.25, 0.5, 1 (0.05 available)					
Temperature coefficient		ppm/ $^{\circ}\text{C}$	$\pm 15, \pm 25, \pm 50, \pm 100, \pm 300$					
TCR tracking		ppm/ $^{\circ}\text{C}$	± 5 , except schematic B below 500 Ω (± 20 ppm/ $^{\circ}\text{C}$)					
Ambient temperature range		$^{\circ}\text{C}$	-55 to +150					
Noise level		dB	< -50					
Substrate material			99.5% pure alumina ceramic					
Construction			Epoxy conformal coated, solder assembled					

Moulded TaNFilm® resistor networks are designed for use in applications requiring a high degree of reliability, stability, tight tolerance, close TCR tracking and low noise. The moulded construction provides excellent dimensional stability for automatic insertion. Our continuous feed, high vacuum sputtering process ensures uniform properties from network to network. Precise state-of-the-art laser trimming enables us to easily achieve in the tightest ratios. Passivated tantalum nitride resistor film ensures performance far superior to military

specifications and provides excellent environmental protection.

The versatile nature of our photoetch process makes it possible to supply virtually any circuit configuration needed to meet special customer requirements. Custom circuit designs can be easily achieved with a modest set up charge. Military screening available on all units.

Custom circuits and special testing available. Contact factory for any special features required.

General Note

Welwyn Components reserves the right to make changes in product specification without notice or liability. All information is subject to Welwyn's own data and is considered accurate at time of going to print.

© **Welwyn Components Limited**

Bedlington, Northumberland NE22 7AA, England Tel: 01670 822181 Fax: 01670 829465 Web: <http://www.Welwyn-TT.co.uk>

Issue A 07/99

Performance Data

TEST PER MIL-PRF-83401	MIL-PRF-83401 LIMITS (ΔR%)			TaNFilm TEST DATA (ΔR%)	
	M	K	H	Maximum	Typical
Thermal shock and power conditioning	0.7	0.7	0.5	0.1	0.02
Low temperature operation	0.5	0.25	0.1	0.1	0.02
Short term overload	0.5	0.25	0.1	0.05	0.02
Terminal strength	0.25	0.25	0.25	0.1	0.02
Resistance to solder heat	0.25	0.25	0.1	0.1	0.02
Moisture resistance	0.5	0.5	0.4	0.1	0.02
Shock	0.25	0.25	0.25	0.1	0.02
Vibration	0.25	0.25	0.25	0.1	0.02
Life	2.0	0.5	0.5	0.1	0.02
High temperature exposure	1.0	0.5	0.2	0.1	0.02
Low temperature storage	0.5	0.25	0.1	0.1	0.02
25°C double load	2.0	0.5	0.5	0.05	0.02

Physical Data

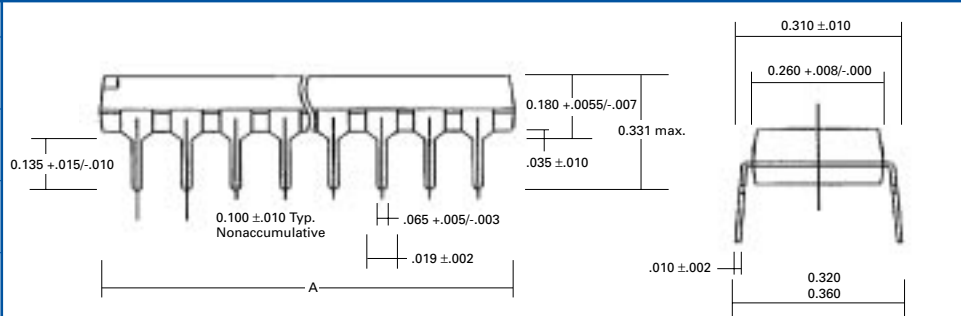
Dimensions (Inches)		
Number of Pins	Variable Dimensions	
8	0.465	
14	0.765	
16	0.865	

Schematics

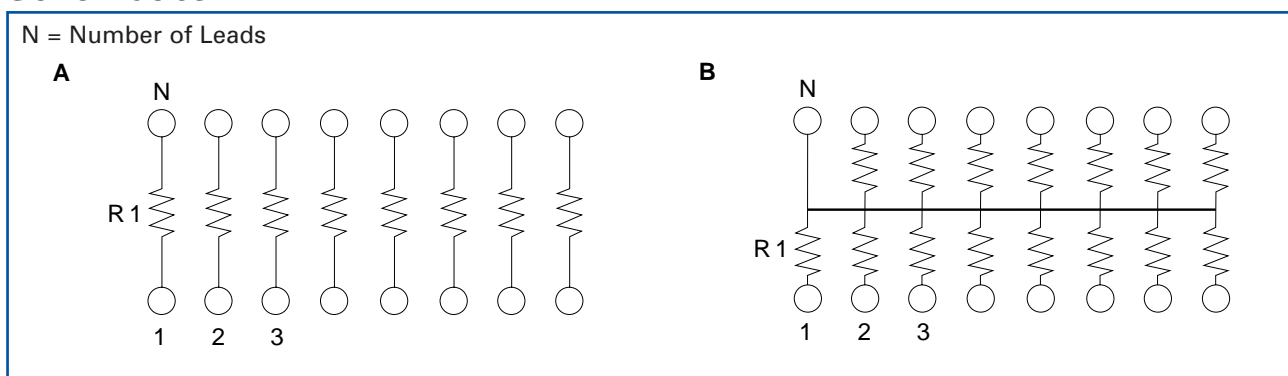

PACKAGING

Resistor networks are supplied in anti-static tubes.

ADDITIONAL ORDERING INFORMATION

Model				
M959	4 resistor	8 pin DIP	straight thru	Schematic A
M954	7 resistor	8 pin DIP	one common lead	Schematic B
M989	7 resistor	14 pin DIP	straight thru	Schematic A
M987	13 resistor	14 pin DIP	one common lead	Schematic B
M999	8 resistor	16 pin DIP	straight thru	Schematic A
M998	15 resistor	16 pin DIP	one common lead	Schematic B