



Integrated Device Technology, Inc.

8K x 9 & 16K x 9 CMOS PARALLEL IN-OUT FIFO MODULE

IDT7MP2005
IDT7MP2011

FEATURES:

- First-In/First-Out memory module
- 8K x 9 organization (IDT7MP2005)
- 16K x 9 organization (IDT7MP2011)
- High speed: 20ns (max.) access time
- Asynchronous and simultaneous read and write
- Fully expandable by both word depth and/or bit width
- MASTER/SLAVE multiprocessing applications
- Bidirectional and rate buffer applications
- Empty and Full warning-flags
- High-performance CEMOS™ technology
- Single 5V (±10%) power supply

DESCRIPTION:

IDT7MP2005/7MP2011 are FIFO memory modules constructed on multi-layered epoxy laminate (FR-4) substrate by mounting two IDT7204 (4K x 9) or IDT7205 (8K x 9) FIFOs in plastic leaded chip carriers. Extremely high speeds are

achieved in this fashion due to the use of IDT7203s and IDT7204s fabricated in IDT's high performance CEMOS technology. These devices utilize an algorithm that loads and empties data on a first-in/first-out basis. The device uses Full and Empty flags to prevent data overflow and underflow and expansion logic to allow for unlimited expansion capability in both word size and depth.

The reads and writes are internally sequential through the use of ring pointers, with no address information required to load and unload data. Data is toggled in and out of the device through the use of the WRITE (\bar{W}) and READ (\bar{R}) pins. The devices have a read/write cycle time of 30ns (min.) for commercial temperature ranges.

The devices utilize a 9-bit wide data array to allow for control and parity bits at the user's option. This feature is especially useful in data communications applications where it is necessary to use a parity bit for transmission/reception error checking.

PIN CONFIGURATION⁽¹⁾

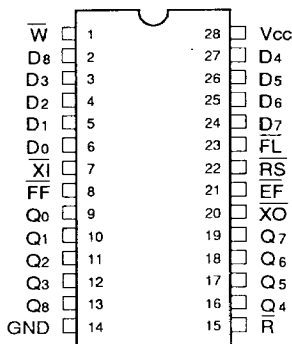

DSIP
TOP VIEW

2709 drw 01

NOTE:

1. For module dimensions, please refer to drawing M34 in the packaging section.

PIN NAMES

\bar{W} = WRITE	\bar{FL} = FIRST LOAD	\bar{XI} = EXPANSION IN	\bar{EF} = EMPTY FLAG
\bar{R} = READ	D = DATA _{IN}	\bar{XO} = EXPANSION OUT	V _{CC} = POWER
RS = RESET	Q = DATA _{OUT}	FF = FULL FLAG	GND = GROUND

FUNCTIONAL BLOCK DIAGRAM

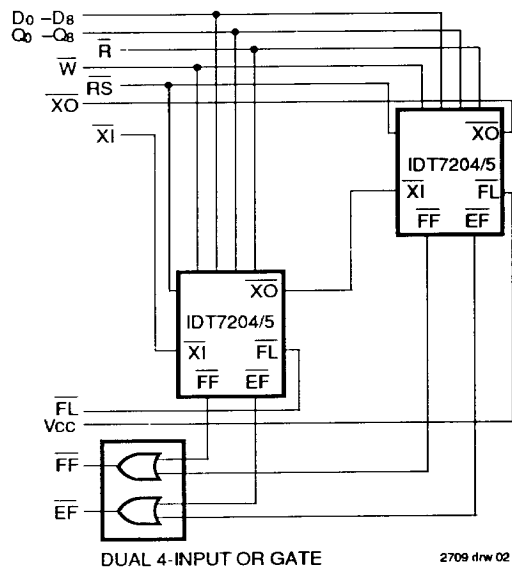

DUAL 4-INPUT OR GATE

2709 drw 02

CEMOS is a trademark of Integrated Device Technology, Inc.

COMMERCIAL TEMPERATURE RANGE

SEPTEMBER 1990

ABSOLUTE MAXIMUM RATINGS⁽¹⁾

Symbol	Rating	Com'l.	Unit
VTERM	Terminal Voltage with Respect to GND	-0.5 to +7.0	V
TA	Operating Temperature	0 to +70	°C
TBIAS	Temperature Under Bias	-55 to +125	°C
TSTG	Storage Temperature	-55 to +125	°C
IOUT	DC Output Current	50	mA

NOTE: 2709 tbl 02
1. Stresses greater than those listed under ABSOLUTE MAXIMUM RATINGS may cause permanent damage to the device. This is a stress rating only and functional operation of the device at these or any other conditions above those indicated in the operational sections of this specification is not implied. Exposure to absolute maximum rating conditions for extended periods may affect reliability.

RECOMMENDED DC OPERATING CONDITIONS

Symbol	Parameter	Min.	Typ.	Max.	Unit
VCC	Commercial Supply Voltage	4.5	5.0	5.5	V
GND	Supply Voltage	0	0	0	V
V _{IH} ⁽¹⁾	Input High Voltage Commercial	2.0	—	—	V
V _{IL} ⁽¹⁾	Input Low Voltage Commercial	—	—	0.8	V

NOTE: 2709 tbl 03
1. 1.5V undershoots are allowed for 10ns once per cycle.

CAPACITANCE (TA = +25°C, f = 1.0 MHz)

Symbol	Parameter ⁽¹⁾	Conditions	Max.	Unit
CIN	Input Capacitance	V _{IN} = 0V	20	pF
COUT	Output Capacitance	V _{OUT} = 0V	25	pF

NOTE: 2709 tbl 04
1. This parameter is guaranteed by design but not tested.

DC ELECTRICAL CHARACTERISTICS

(VCC = 5.0V ±10%, TA = 0°C to +70°C)

Symbol	Parameter	IDT7MP2005 ⁽⁴⁾		IDT7MP2011 ⁽⁵⁾		IDT7MP2005 ⁽⁶⁾		Unit
		Min.	Max.	Min.	Max.	Min.	Max.	
I _{LI} ⁽¹⁾	Input Leakage Current (Any Input)	—	20	—	20	—	20	µA
I _{OL} ⁽²⁾	Output Leakage Current	—	20	—	20	—	20	µA
V _{OH}	Output Logic "1" Voltage I _{OUT} = -2mA	2.4	—	2.4	—	2.4	—	V
V _{OL}	Output Logic "0" Voltage I _{OUT} = 8mA	—	0.4	—	0.4	—	0.4	V
I _{CC1} ⁽³⁾	Operating Current	—	320	—	300	—	132	mA
I _{CC2} ⁽³⁾	Average Standby Current ($\bar{R} = \bar{W} = \bar{RS} = \bar{FL}/RT = V_{IH}$)	—	30	—	24	—	24	mA
I _{CC3} ⁽³⁾	Power Down Current (All Input = VCC - 0.2V)	—	16	—	16	—	16	mA

NOTES: 2709 tbl 04
1. Measurements with 0.4 ≤ V_{IN} ≤ V_{OUT}.
2. R ≥ V_{IH}, 0.4 ≤ V_{OUT} ≤ V_{CC}.
3. I_{CC} measurements are made with outputs open.
4. t_{AA} = 20, 25, 30, 35ns.
5. t_{AA} = 30, 35, 40, 50, 60, 70, 85, 120ns.
6. t_{AA} = 40, 50, 60, 70, 85, 120ns.

AC TEST CONDITIONS

Input Pulse Levels	GND to 3.0V
Input Rise/Fall Times	5ns
Input Timing Reference Levels	1.5V
Output Reference Levels	1.5V
Output Load	See Figure 1, 2 & 3

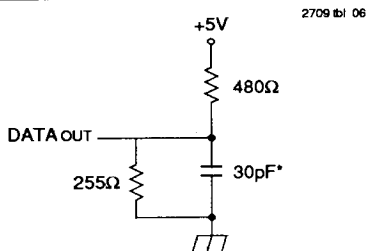

Figure 1. Output Load

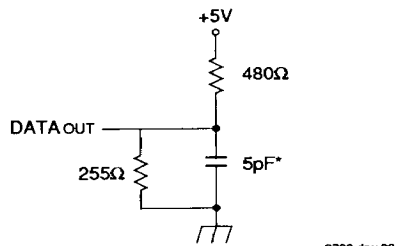

Figure 2. Output Load (for tRLZ, tWLZ, and tRHZ)

* Includes scope and jig capacitances.

AC ELECTRICAL CHARACTERISTICS

(VCC = 5.0V±10%, TA = 0°C to +70°C)

Symbol	Parameter	7MP2005S20		7MP2005S25		7MP2005S30 7MP2011S30		7M205SS35 7M2011S35		Unit
		Min.	Max.	Min.	Max.	Min.	Max.	Min.	Max.	
tRC	Read Cycle Time	30	—	35	—	40	—	45	—	ns
tA	Access Time	—	20	—	25	—	30	—	35	ns
tRR	Read Recovery Time	10	—	10	—	10	—	10	—	ns
tRPW ⁽¹⁾	Read Pulse Width	20	—	25	—	30	—	35	—	ns
tRLZ ⁽²⁾	Read Pulse Low to Data Bus at Low Z	5	—	5	—	5	—	5	—	ns
tWLZ ⁽²⁾	Write Pulse High to Data Bus at Low Z	5	—	5	—	10	—	10	—	ns
tDV	Data Valid from Read Pulse High	5	—	5	—	5	—	5	—	ns
tRHZ ⁽²⁾	Read Pulse High to Data Bus at High Z	—	13	—	20	—	20	—	20	ns
tWC	Write Cycle Time	30	—	35	—	40	—	45	—	ns
tWPW ⁽¹⁾	Write Pulse Width	20	—	25	—	30	—	35	—	ns
tWR	Write Recovery Time	10	—	10	—	10	—	10	—	ns
tDS	Data Set-up Time	15	—	18	—	18	—	20	—	ns
tDH	Data Hold Time	0	—	0	—	0	—	0	—	ns
tRSC	Reset Cycle Time	30	—	35	—	40	—	45	—	ns
tRS ⁽¹⁾	Reset Pulse Width	20	—	25	—	30	—	35	—	ns
tRSR	Reset Recovery Time	10	—	10	—	10	—	10	—	ns
tEFL	Reset to Empty Flag Low	—	30	—	35	—	40	—	45	ns
tREF	Read Low to Empty Flag Low	—	20	—	25	—	30	—	35	ns
tRFF	Read High to Full Flag High	—	23	—	25	—	30	—	35	ns
tWEF	Write High to Empty Flag High	—	23	—	25	—	30	—	35	ns
tWFF	Write Low to Full Flag Low	—	20	—	25	—	30	—	35	ns

NOTES:

1. Pulse widths less than minimum value are not allowed.
2. This parameter is guaranteed by design but not tested.

2709 tbl 05

AC ELECTRICAL CHARACTERISTICS

(VCC = 5.0V±10%, TA = 0°C to +70°C)

Symbol	Parameter	7MP2005S40	7MP2005S50	7MP2005S60	7MP2005S70	7MP2005S85	7MP2005S120	Unit						
		7MP2011S40	7MP2011S50	7MP2011S60	7MP2011S70	7MP2011S85	7MP2011S120							
		Min.	Max.	Min.	Max.	Min.	Max.	Min.	Max.					
tRC	Read Cycle Time	50	—	65	—	75	—	85	—	105	—	140	—	ns
tA	Access Time	—	40	—	50	—	60	—	70	—	85	—	120	ns
tRR	Read Recovery Time	10	—	15	—	15	—	15	—	20	—	20	—	ns
tRPW ⁽¹⁾	Read Pulse Width	40	—	50	—	60	—	70	—	85	—	120	—	ns
tRLZ ⁽²⁾	Read Pulse Low to Data Bus at Low Z	5	—	10	—	10	—	10	—	10	—	10	—	ns
tWLZ ⁽²⁾	Write Pulse High to Data Bus at Low Z	10	—	15	—	15	—	15	—	20	—	20	—	ns
tDV	Data Valid from Read Pulse High	5	—	5	—	5	—	5	—	5	—	5	—	ns
tRHZ ⁽²⁾	Read Pulse High to Data Bus at High Z	—	25	—	30	—	30	—	30	—	30	—	35	ns
tWC	Write Cycle Time	50	—	65	—	75	—	85	—	105	—	140	—	ns
tWPW ⁽¹⁾	Write Pulse Width	40	—	50	—	60	—	70	—	85	—	120	—	ns
tWR	Write Recovery Time	10	—	15	—	15	—	15	—	20	—	20	—	ns
tDS	Data Set-up Time	20	—	30	—	30	—	30	—	40	—	40	—	ns
tDH	Data Hold Time	0	—	5	—	5	—	10	—	10	—	10	—	ns
tRSC	Reset Cycle Time	50	—	65	—	75	—	85	—	105	—	140	—	ns
tRS ⁽¹⁾	Reset Pulse Width	40	—	50	—	60	—	70	—	85	—	120	—	ns
tRSR	Reset Recovery Time	10	—	15	—	15	—	15	—	20	—	20	—	ns
tEFL	Reset to Empty Flag Low	—	50	—	65	—	75	—	85	—	105	—	140	ns
tREF	Read Low to Empty Flag Low	—	40	—	50	—	60	—	70	—	85	—	120	ns
tRFF	Read High to Full Flag High	—	40	—	50	—	60	—	70	—	85	—	120	ns
tWEF	Write High to Empty Flag High	—	40	—	50	—	60	—	70	—	85	—	120	ns
tWFF	Write Low to Full Flag Low	—	40	—	50	—	60	—	70	—	85	—	120	ns

NOTES:

1. Pulse widths less than minimum value are not allowed.
2. This parameter is guaranteed by design but not tested.

2709 tbl 06

SIGNAL DESCRIPTIONS:

INPUTS:

DATA IN (D₀-D₈)

Data inputs for 9-bit wide data path.

CONTROLS:

RESET (\overline{RS})

Reset is accomplished whenever the RESET (\overline{RS}) input is taken to a low state. During RESET, both internal read and write pointers are set to the first location. A reset is required after power up before a write operation can take place. Both the READ ENABLE (\overline{R}) and WRITE ENABLE (\overline{W}) inputs must be in the high state during reset.

WRITE ENABLE (\overline{W})

A write cycle is initiated on the falling edge of this input if the FULL FLAG (\overline{FF}) is not set. Data set-up and hold times must be adhered to with respect to the rising edge of the WRITE ENABLE (\overline{W}). Data is stored in the RAM array sequentially and independently of any ongoing read operation.

To prevent data overflow, the FULL FLAG (\overline{FF}) will go low, inhibiting further write operations. Upon the completion of a valid read operation, the FULL FLAG (\overline{FF}) will go high after t_{RF}, allowing a valid write to begin.

READ ENABLE (\overline{R})

A read cycle is initiated on the falling edge of the READ ENABLE (\overline{R}) provided the EMPTY FLAG (\overline{EF}) is not set. The data is accessed on a first-in/first-out basis independent of any ongoing write operations. After READ ENABLE (\overline{R}) goes high, the Data Outputs (Q₀ through Q₈) will return to a high impedance condition until the next READ operation. When all the data has been read from the FIFO, the EMPTY FLAG (\overline{EF}) will go low, inhibiting further read operations with the data

outputs remaining in a high impedance state. Once a valid write operation has been accomplished, the EMPTY FLAG (\overline{EF}) will go high after t_{WEF} and a valid READ can then begin.

FIRST LOAD (\overline{FL})

This pin is grounded to indicate that it is the first device. In the multiple module (depth expansion mode) application, this pin on the rest of devices should connect to V_{CC} for proper operation.

EXPANSION IN (\overline{XI})

EXPANSION IN (\overline{XI}) is connected to EXPANSION OUT (\overline{XO}) of the previous (in depth expansion) or same device for proper applications.

OUTPUTS:

FULL FLAG (\overline{FF})

The FULL FLAG (\overline{FF}) will go low, inhibiting further write operation, when the write pointer is one location from the read pointer, indicating that the device is full. If the read pointer is not moved after RESET (\overline{RS}), the FULL FLAG (\overline{FF}) will go low after 8,192 writes for the IDT7MP2005 and 16,384 writes for the IDT7MP2011.

EXPANSION OUT (\overline{XO})

EXPANSION OUT (\overline{XO}) is connected to the EXPANSION IN (\overline{XI}) of the same device (single device mode) or the EXPANSION IN (\overline{XI}) of the next device (multiple device, depth expansion mode) for proper operation. This output acts as a signal to the next device by providing a pulse to the next device when the current device reaches the last location of memory.

DATA OUTPUTS (Q₀-Q₈)

Data outputs for a 9-bit wide data path. This output is in a high impedance condition whenever READ (\overline{R}) is in a high state.

TIMING WAVEFORM OF RESET CYCLE^(1,2)

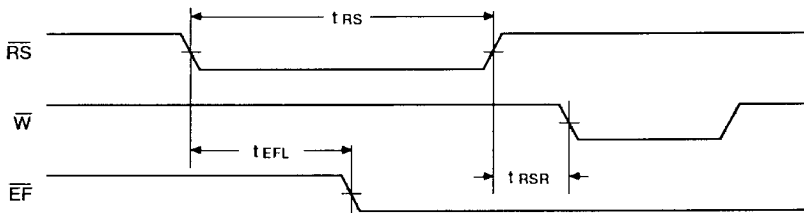

2709 dhw 04

NOTES:

1. t_{RSC} = t_{RS} + t_{RSR}
2. \overline{W} and \overline{R} = V_{IH} during RESET.

TIMING WAVEFORM OF ASYNCHRONOUS WRITE AND READ OPERATION

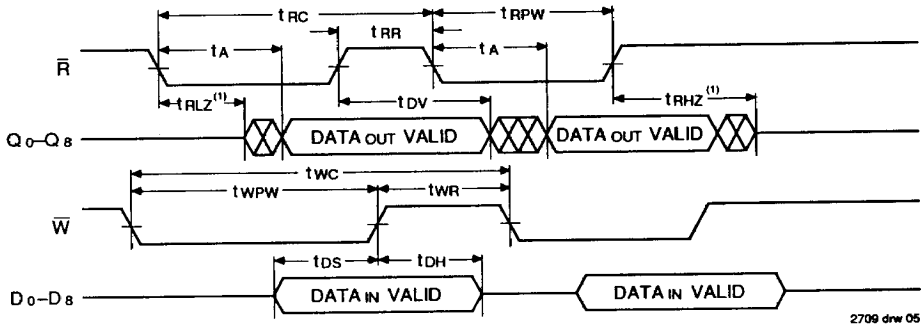

2709 drw 05

TIMING WAVEFORM FOR THE FULL FLAG FROM LAST WRITE TO FIRST READ

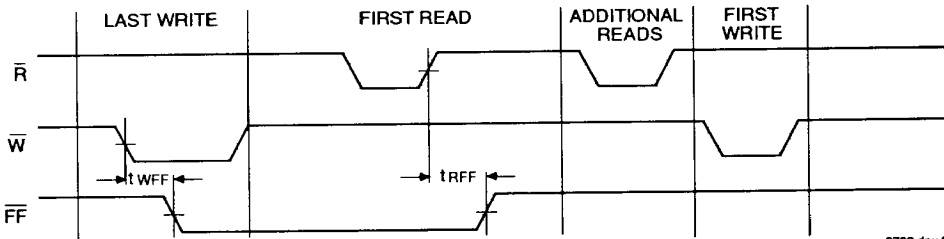

2709 drw 06

TIMING WAVEFORM FOR THE EMPTY FLAG FROM LAST READ TO FIRST WRITE

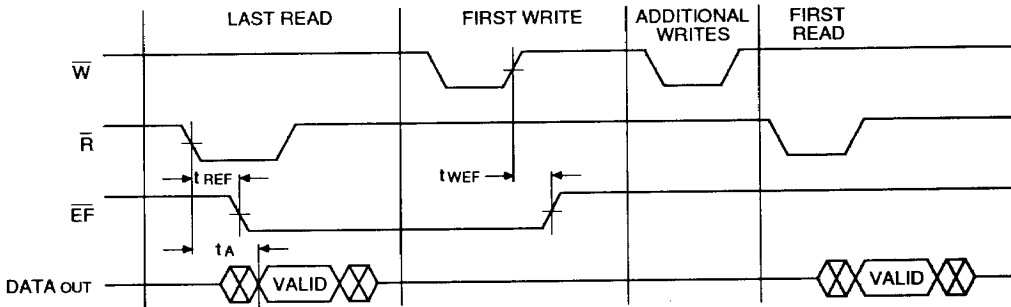

2709 drw 07

NOTE:
 1. This parameter is guaranteed by design but not tested.

TIMING WAVEFORM OF THE EMPTY FLAG CYCLE

t_{RPE} EFFECTIVE READ PULSE WIDTH AFTER FULL FLAG HIGH ⁽¹⁾

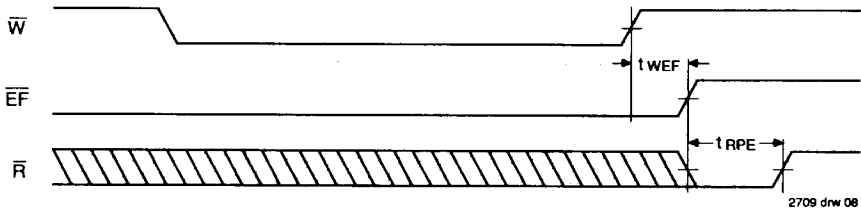

NOTE:
1. ($t_{RPE} = t_{RPW}$)

TIMING WAVEFORM OF THE FULL FLAG CYCLE

t_{RPF} EFFECTIVE READ PULSE WIDTH AFTER FULL FLAG HIGH ⁽¹⁾

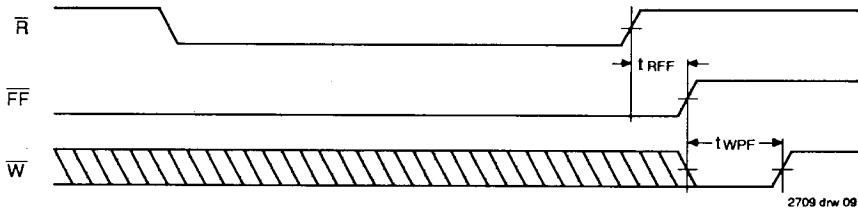

NOTE:
1. ($t_{WPF} = t_{WPW}$)

OPERATING MODES

SINGLE DEVICE MODE

A single IDT7MP2005/2011 may be used when the application requirements are for 8,192/16,384 words or less. The IDT7MP2005/2011 is in a Single Device Configuration when the EXPANSION IN ($\bar{X}I$) control input is connected to the EXPANSION OUT ($\bar{X}O$) of the device and the FIRST LOAD ($\bar{F}L$) control pin is grounded (see Figure 8).

WIDTH EXPANSION MODE

Word width may be increased simply by connecting the corresponding input control signals of multiple devices. Status flags ($\bar{E}F$ and $\bar{F}F$) can be detected from any one device. Figure 9 demonstrates an 18-bit word width by using two IDT7MP2005/2011. Any word width can be attained by adding additional IDT7MP2005/2011s.

DEPTH EXPANSION (DAISY CHAIN) MODE

The IDT7MP2005/2011 can easily be adapted to applications when the requirements are for greater than 8,192/16,384 words. Figure 10 demonstrates Depth Expansion using three IDT7MP2005/2011. Any depth can be attained by adding additional IDT7MP2005/2011s. The IDT7MP2005/2011 operate in the Depth Expansion configuration when the following conditions are met:

1. The first device must be designated by grounding the FIRST LOAD ($\bar{F}L$) control input.
2. All other devices must have $\bar{F}L$ in the high state.
3. The EXPANSION OUT ($\bar{X}O$) pin of each device must be tied to the EXPANSION IN ($\bar{X}I$) pin of the next device. (See Figure 10.)

4. External logic is needed to generate a composite FULL FLAG ($\bar{F}F$) and EMPTY FLAG ($\bar{E}F$). This requires the logical ANDing of all $\bar{E}F$ s and logical ANDing of all $\bar{F}F$ s (i.e. all must be set to generate the correct composite $\bar{F}F$ or $\bar{E}F$). (See Figure 10.)

COMPOUND EXPANSION MODE

The two expansion techniques described above can be applied together in a straight forward manner to achieve large FIFO arrays. (See Figure 11.)

BIDIRECTIONAL MODE

Applications which require data buffering between two systems (each system capable of READ and WRITE operations) can be achieved by pairing IDT7MP2005/2011s as shown in Figure 12. Care must be taken to assure that the appropriate flag is monitored by each system (i.e. $\bar{F}F$ is monitored on the device where W is used; $\bar{E}F$ is monitored on the device where \bar{R} is used). Both Depth Expansion and Width Expansion may be used in this mode.

DATA FLOW-THROUGH MODES

Two types of flow-through modes are permitted with the IDT7MP2005/2011: a read flow-through mode and write flow-through mode. For the read flow-through mode (Figure 13), the FIFO permits a reading of a single word of data immediately after writing one word of data into the completely empty FIFO.

In the write flow-through mode (Figure 14), the FIFO permits a writing of a single word of data immediately after reading one word of data from a completely full FIFO.

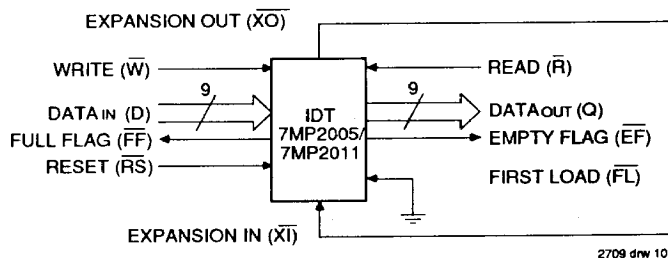
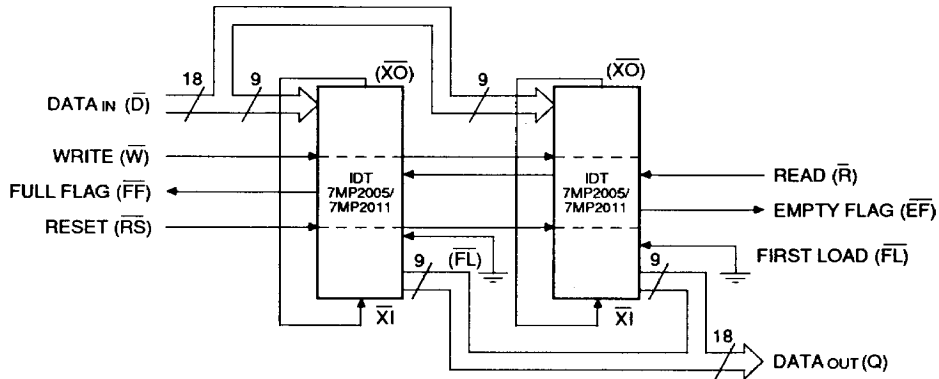

Figure 8. Block Diagram of Single IDT7MP2005/7MP2011 FIFO



2709 drw 11

NOTE:
1. Flag detection is accomplished by monitoring the FF and EF signals on either (any) device used in the width expansion configuration. Do not connect any output control signals together.

Figure 9. Block Diagram of 8,192 x 18/16,384 x 18 FIFO Memory Used In Width Expansion Mode

TRUTH TABLES
TABLE I—RESET

Single Device Configuration/Width Expansion Mode

Mode	Inputs		Internal Status		Outputs	
	RS̄	X̄I	Read Pointer	Write Pointer	EF	FF
Reset	0	0	Location Zero	Location Zero	0	1
Read/Write	1	0	Increment ⁽¹⁾	Increment ⁽¹⁾	X	X

NOTE:
1. Pointer will increment if flag is High. 2709 tbl 08

TABLE II—RESET AND FIRST LOAD TRUTH TABLE

Depth Expansion/Compound Expansion Mode

Mode	Inputs			Internal Status		Outputs	
	RS̄	FL̄	X̄I	Read Pointer	Write Pointer	EF	FF
Reset First Device	0	0	(1)	Location Zero	Location Zero	0	1
Reset All Other Devices	0	1	(1)	Location Zero	Location Zero	0	1
Read/Write	1	X	(1)	X	X	X	X

NOTE:
1. X̄I is connected to X̄O of previous device. See Figure 10.
2. RS̄ = Reset Input, FL̄ = First Load, EF̄ = Empty Flag Output, FF̄ = Flag Full Output, X̄I = Expansion Input. 2709 tbl 09

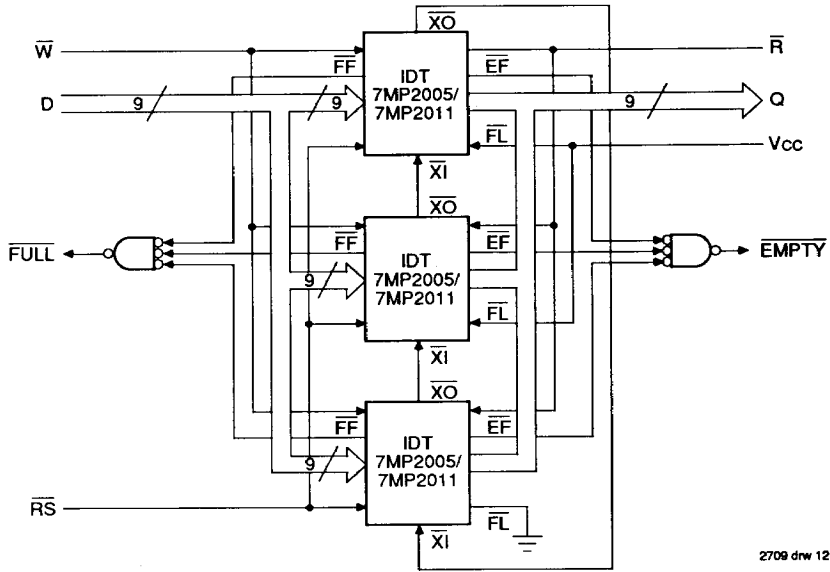

Figure 10. Block Diagram of 24,576 x 9/49,152 x 9 FIFO Memory (Depth Expansion)

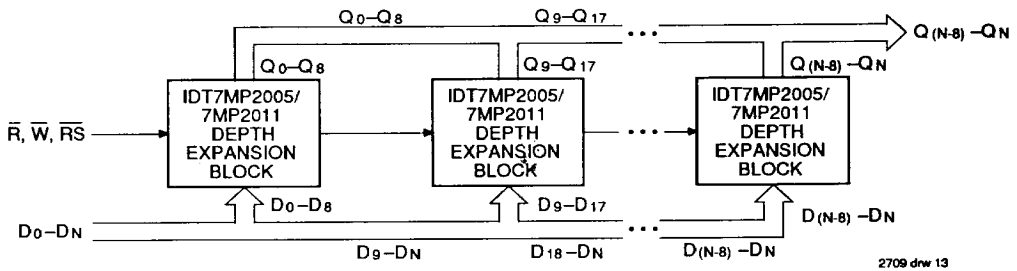
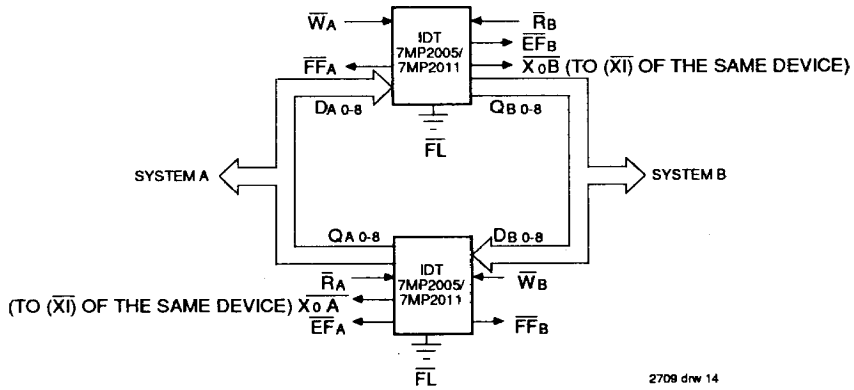

Figure 11. Compound FIFO Expansion

NOTES:

1. For depth expansion block see DEPTH EXPANSION Section and Figure 10.
2. For Flag detection see WIDTH EXPANSION Section and Figure 9.



2709 drw 14

Figure 12. Bidirectional FIFO Mode

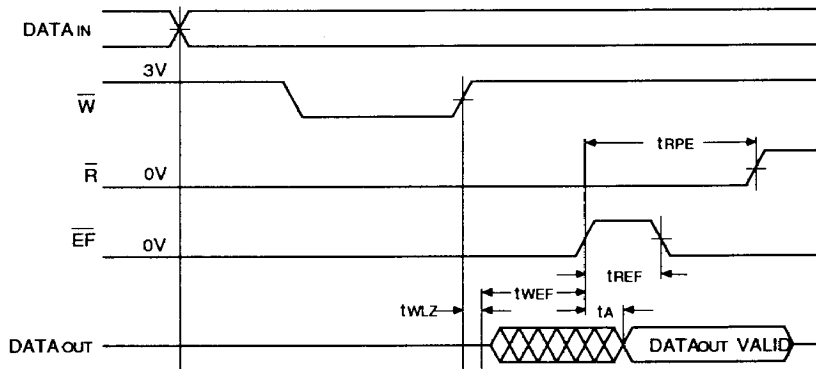

2709 drw 15

Figure 13. Read Data Flow-Through Mode

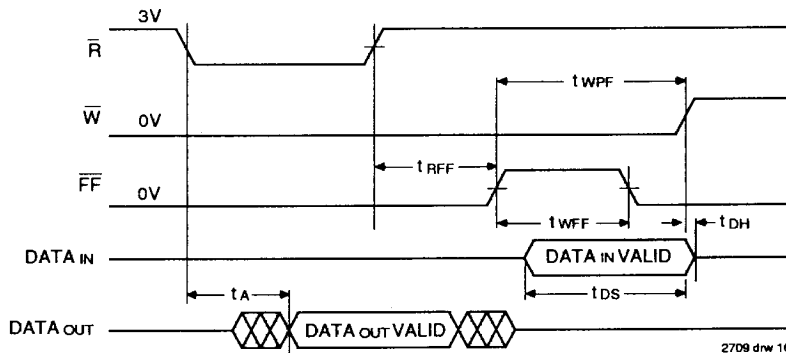

2709 drw 16

Figure 14. Write Data Flow-Through Mode

ORDERING INFORMATION

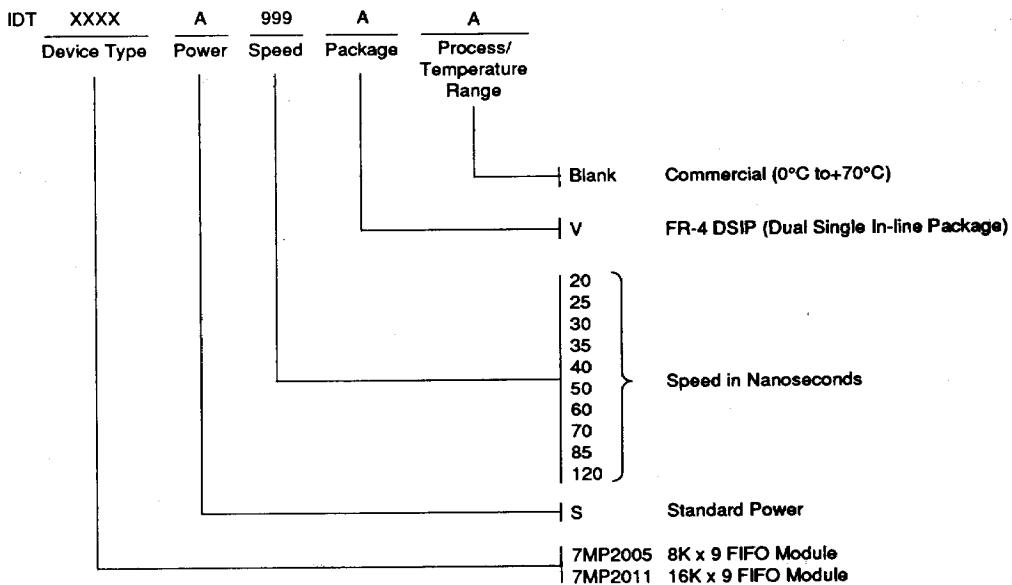

2708 dw 17