

RIC CONNECTOR

Disconnectable Crimp style Wire-to-wire connectors

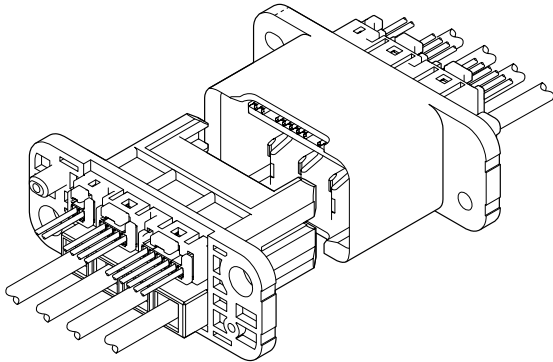

This connector is a hybrid type double-row drawer connector to connect the units, absorbs misalignment between units, and excels durability. RCZ connector with lever locking device is adopted as applicable socket to prevent coming off the socket and incomplete mating.

- Corresponding to space saving and lever locking type socket
- Absorbed misalignment mechanism
- High durability
- Hybrid type

Specifications

- Current rating: Signal circuit/1.0A AC, DC (AWG#26)
Power supply circuit/15A AC, DC (AWG#14)
- Voltage rating: Signal circuit/50V AC, DC
Power supply circuit/250V AC, DC
- Temperature range: -25°C to +85°C
(including temperature rise in applying electrical current)
- Contact resistance:
 - Signal circuit Initial value/40m Ω max.
After environmental testing/60m Ω max.
 - Power supply circuit Initial value/10m Ω max.
After environmental testing/20m Ω max.
- Insulation resistance: 500M Ω min.
- Withstanding voltage: Signal circuit 500V AC/minute
Power supply circuit 1,500V AC/minute
- Applicable wire: Signal circuit Applicable socket/RCZ connector
Power supply circuit Conductor size/AWG#18 to #14
Insulation O.D./2.0 to 3.6mm
- Mounting method: Screw
- * Compliant with RoHS.
- * Refer to "General Instruction and Notice when using Terminals and Connectors" at the end of this catalog.
- * Contact JST for details.

Standards

- Ⓜ Recognized E60389
- Ⓢ Certified LR20812
- ⚠ J50106515

PC board layout and Assembly layout

Plug

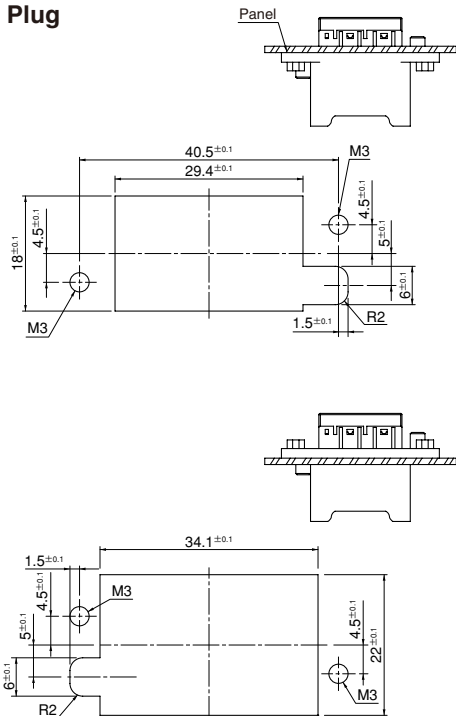

Receptacle

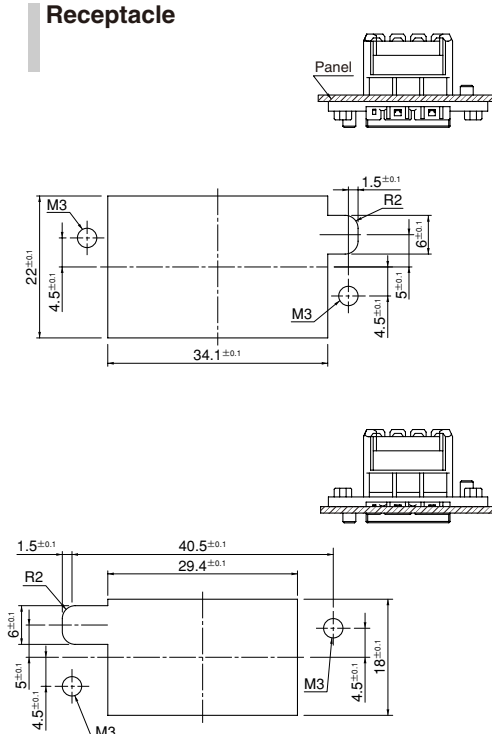

Assembly layout

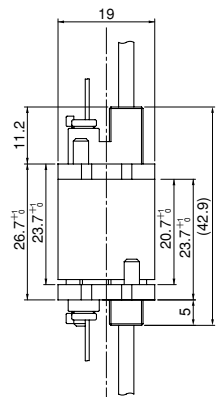

- Note: 1. Punch holes in the panel according to the figures shown above. Burrs must be removed.
2. The strength of the panel must be considered when punching two or more holes.
3. The connector must be inserted from the same side as the hole is punched.

Plug contact for power supply circuit

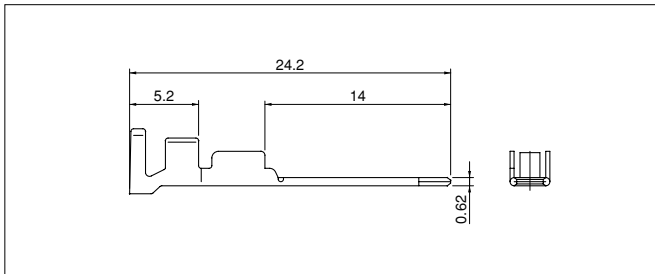

Model No.	Applicable wire		Insulation O.D. (mm)	Q'ty / reel
	mm ²	AWG #		
SRICM-61GG-S0.6	0.75~2.0	18~14	2.0~3.6	3,000

Material and Finish

Copper alloy, nickel-undercoated, Mating part; gold-plated
Crimping part; tin-plated (reflow treatment)

RoHS compliance This product displays (LF)(SN) on a label.

Contact	Crimping machine	Applicator		
		Crimp applicator	Dies	Crimp applicator with dies
SRICM-61GG-S0.6	AP-K2N	MKS-L	MK/SRPF/IC/M-61-06	APLMK SRPF/IC/M61-06
		—	—	—

Receptacle contact for power supply circuit

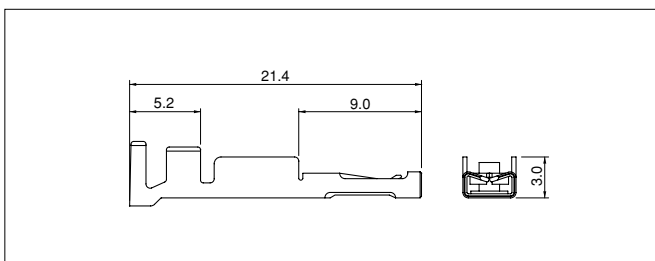

Model No.	Applicable wire		Insulation O.D. (mm)	Q'ty / reel
	mm ²	AWG #		
SRWF-61GG-M0.6	0.75~2.0	18~14	2.0~3.6	3,000

Material and Finish

Copper alloy, nickel-undercoated, Mating part; gold-plated
Crimping part; tin-plated (reflow treatment)

RoHS compliance This product displays (LF)(SN) on a label.

Contact	Crimping machine	Applicator		
		Crimp applicator	Dies	Crimp applicator with dies
SRWF-61GG-M0.6	AP-K2N	MKS-L	MK/SRPF/M-61-06	APLMK SRPF/M61-06
		—	—	—

Plug

Hybrid type (Connector with integrated signal and power)

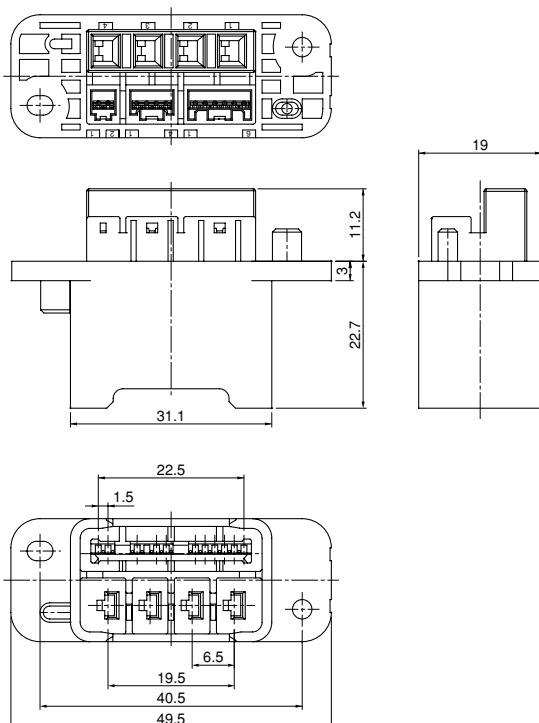

Circuits		Model No.	Q'ty / box
Power supply	Signal		
4	12	12LP-RIC-K2GG-P4	45

Material and Finish

Contact: Copper alloy, nickel-undercoated, selective gold-plated tin-plated (reflow-treatment)
Housing: PBT, UL94V-0, black

RoHS compliance This product displays (LF)(SN) on a label.

RIC CONNECTOR

Receptacle

Hybrid type (Connector with integrated signal and power)

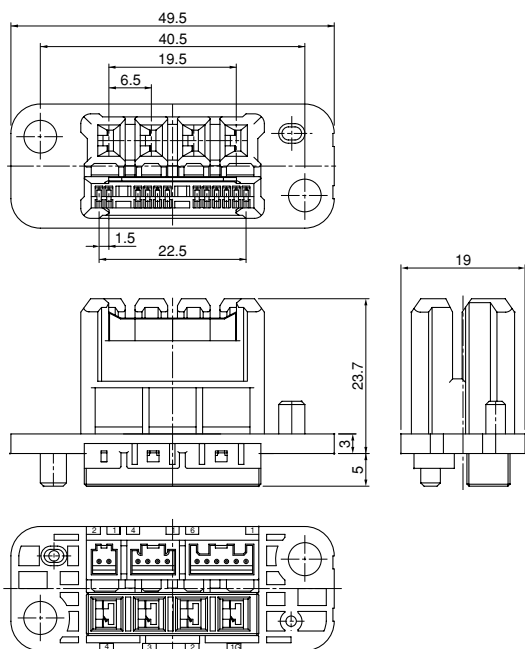

Circuits		Model No.	Q'ty / box
Power supply	Signal		
4	12	12LR-RIC-K4GG-R4	60

Material and Finish

Contact: Copper alloy, nickel-undercoated, selective gold-plated tin-plated (reflow-treatment)
Housing: PBT, UL94V-0, black

RoHS compliance This product displays (LF)(SN) on a label.

CZH connector contact (for RCZ connector)

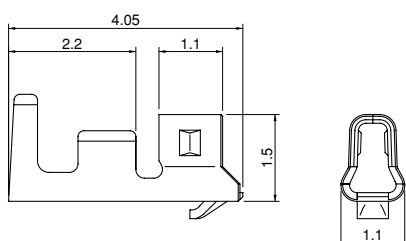

Model No.	Applicable wire		Insulation O.D. (mm)	Q'ty / reel
	mm ²	AWG #		
SCZH-002T-P0.5	0.08~0.13	28~26	0.8~1.1	13,000

Material and Finish

Copper alloy, tin-plated (reflow treatment)

RoHS compliance

Contact	Crimping machine	Applicator		
		Crimp applicator	Dies	Crimp applicator with dies
SCZH-002T-P0.5	AP-K2N	MKS-L	MK/SCZH-002-05	APLMK SCZH002-05
		-	-	-

RCZ connector socket housing

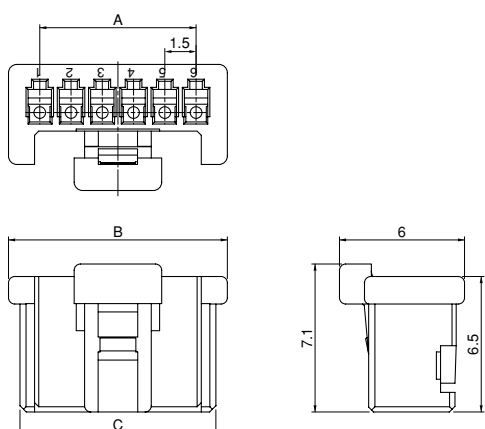

Circuits	Model No.	Dimensions (mm)			Q'ty / bag
		A	B	C	
2	RCZR-02V-PS-S	1.5	4.5	3.4	1,000
4	RCZR-04V-PS-S	4.5	7.5	6.4	1,000
6	RCZR-06V-PS-S	7.5	10.5	9.4	1,000

Material

PA 66, UL94V-0, natural (white)

RoHS compliance