

Features

- High power converter
- High efficiency
- Excellent transient response
- Sense pins
- Surface-mount construction
- Voltage trim
- Low profile
- Water washable

Description

UPM non-isolated DC/DC buck converters deliver high power and excellent transient response in a compact 1.0" x 2.0" x 0.475" package. The UPM can provide up to 40 watts of output power at 12A output current, and output voltages from 1.2 to 3.3V. Featuring open-frame, 100% surface-mount construction and high efficiency, the UPM excels in difficult thermal environments.

Technical Specifications

Input	
Voltage Range	3.0 - 3.6 VDC
3.3 VDC Nominal	4.5 - 5.5 VDC
5.0 VDC Nominal	

Output	
Setpoint Accuracy	±1%
Line Regulation V_{in} Min. - V_{in} Max., I_{out} Rated	1% V_{out}
Load Regulation I_{out} Min. - I_{out} Max., V_{in} Nom.	1% V_{out}
Ripple and Noise, DC - 200 MHz	50 mV Pk-Pk
Remote Sense Headroom	0.25 V
Current Limit Protection Type	Hiccup
Current Limit Threshold Range, % of I_{out} Rated	130%
Short Circuit Protection Type	Latching
V_{out} Ramp Up Rate, Minimum	0.5V/ms

General	
Switching Frequency	200 kHz
Temperature Coefficient	50 ppm/°C
Baseplate Operating Temperature	0 to +100°C
Storage Range	-40 to +100°C
Internal Input Capacitance	500 μ F Max.
Recommended External Capacitance	
Input	200 μ F/A I_{out}
Output	200 μ F/A I_{out}
Load Capacitance Compensation	User Selectable
Humidity Max., Non-Condensing	95%
Vibration, 3 Axes, 5 Min Each	5 g, 10 - 55 Hz
MTBF† (Bellcore TR-NWT-000332)	2.9×10^6 hrs
Safety	UL, CSA, EN60950
Weight (approx.)	0.9 oz

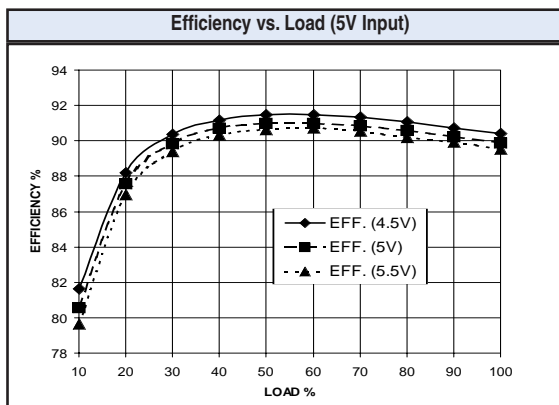

Notes
† MTBF predictions may vary slightly from model to model.
Specifications typically at 25°C, normal line, and full load, unless otherwise stated.
Soldering Conditions: I/O pins, 260°C, ten seconds: fully compatible with commercial wave-soldering equipment.
Safety: Agency approvals may vary from model to model. Please consult factory for specific model information.
Units are water-washable and fully compatible with commercial spray or immersion post wave-solder washing equipment.

Model Selection

Vin (Volts)	Vin Range (Volts)	Iin Max* (Amps)	Vout (Volts)	Iout Rated (Amps)	Efficiency Typ. **	Model
3.3	3.0 - 3.6	5.2	1.2	12	78%	UPM301.2
3.3	3.0 - 3.6	6.3	1.5	12	79%	UPM301.5
3.3	3.0 - 3.6	7.5	1.8	12	81%	UPM301.8
3.3	3.0 - 3.6	8.5	2.1	12	82%	UPM302.1
5	4.5 - 5.5	4.1	1.2	12	78%	UPM501.2 †
5	4.5 - 5.5	5.1	1.5	12	79%	UPM501.5
5	4.5 - 5.5	6.0	1.8	12	81%	UPM501.8
5	4.5 - 5.5	6.8	2.1	12	82%	UPM502.1
5	4.5 - 5.5	7.9	2.5	12	84%	UPM502.5
5	4.5 - 5.5	10.0	3.3	12	88%	UPM503.3

† Denotes advanced product release. Consult factory for product availability.

* Maximum input current at minimum input voltage, maximum rated output power.

** At nominal Vin, rated output.

Mechanical Drawing

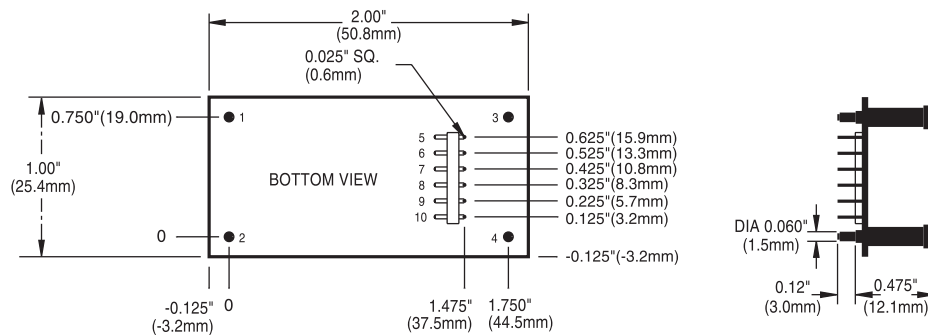

Thermal Impedance	
Natural Convection	9.4 °C/W
100 LFM	6.6 °C/W
200 LFM	4.3 °C/W
300 LFM	3.2 °C/W
400 LFM	2.7 °C/W
Note: Thermal impedance data is dependent on many environmental factors. The exact thermal performance should be validated for specific application.	

Pin	Function
1	-Vin
2	+Vin
3	-Vout
4	+Vout
5	-Vsense
6	Ground
7	Loop Comp.
8	No Conn.
9	Trim
10	+Vsense

Tolerances	
Inches:	(Millimeters)
.XX ± 0.020	.X ± 0.5
.XXX ± 0.010	.XX ± 0.25
Pin:	
± 0.002	± 0.05
(Dimensions as listed unless otherwise specified.)	

This page is offered as a reference. Consult factory for actual availability of options. When ordering equipment options, use the following suffix information. Select preferred option(s) and add the suffix to the model number. Ordering option examples are located below the options table.

OPTION	SUFFIX	APPLICABLE SERIES	REMARKS
Negative Logic	N	HAS, HBD, HBS, HES, HLS, HLD, LES, QBS, QES, QLS, TES, TQD	TTL "Low" Turns Module ON TTL "High" Turns Module OFF
Lucent-Compatible Trim	T	HAS, HBD, HBS, HES, HLS, QBS, QES, QLS	
Trim	1	IAS, LES	
Enable	2	IAD, IAS, LES, SMS	
Trim and Enable	3	IAS, LES	
Pin Length and Heatsink Options			Standard Pin Length is 0.180" (4.6mm)
0.110" (2.8mm) Pin Length	8	All Leaded Models	
0.150" (3.8mm) Pin Length	9	All Leaded Models	
0.24" (6.1mm) Horizontal Heatsink	1H	All 1/4-Bricks, 1/2-Bricks, 3/4-Bricks, Full-Bricks (Except HLS, HLD, QLS, TLD, and TKD Packages)	Includes Thermal Pad
0.24" (6.1mm) Vertical Heatsink	1V	All 1/4-Bricks, 1/2-Bricks, 3/4-Bricks, Full-Bricks (Except HLS, HLD, QLS, TLD, and TKD Packages)	Includes Thermal Pad
0.45" (11.4mm) Horizontal Heatsink	2H	All 1/4-Bricks, 1/2-Bricks, 3/4-Bricks, Full-Bricks (Except HLS, HLD, QLS, TLD, and TKD Packages)	Includes Thermal Pad
0.45" (11.4mm) Vertical Heatsink	2V	All 1/4-Bricks, 1/2-Bricks, 3/4-Bricks, Full-Bricks (Except HLS, HLD, QLS, TLD, and TKD Packages)	Includes Thermal Pad
0.95" (24.1mm) Horizontal Heatsink	3H	All 1/4-Bricks, 1/2-Bricks, 3/4-Bricks, Full-Bricks (Except HLS, HLD, QLS, TLD, and TKD Packages)	Includes Thermal Pad
0.95" (24.1mm) Vertical Heatsink	3V	All 1/4-Bricks, 1/2-Bricks, 3/4-Bricks, Full-Bricks (Except HLS, HLD, QLS, TLD, and TKD Packages)	Includes Thermal Pad

Example Options:

HBS050ZG-ANT3V = HBS050ZG-A with negative logic, Lucent-compatible trim, and 0.95" vertical heatsink.

LES015YJ-3N = LES015YJ with optional trim and enable, negative logic.

QBS066ZG-AT8 = QBS066ZG-A with Lucent-compatible trim and 0.110" pin length.

NUCLEAR AND MEDICAL APPLICATIONS - Power-One products are not authorized for use as critical components in life support systems, equipment used in hazardous environments, or nuclear control systems without the express written consent of the respective divisional president of Power-One, Inc.

TECHNICAL REVISIONS - The appearance of products, including safety agency certifications pictured on labels, may change depending on the date manufactured. Specifications are subject to change without notice.