

25 or 50 Mil Pitch, T-Filter Resistor/Capacitor Networks

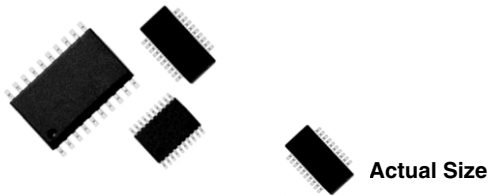

Small Outline, Surface Mount, EMI/RFI Reduction, T-Filter Networks

Vishay Thin Film's schematic AD is designed as an 8 channel filter for use with personal computer and peripheral 110 ports such as SCSI ports. The use of single die technology for filtering minimizes space and allows for more freedom in routing. With a rugged molded case to protect the circuit from the environment and an integrated thin film network this product is your choice when reduced size, improved accuracy and surface mount capability are your goals.

Available packages SOIC, SSOP and TSSOP.

SCHEMATIC AD

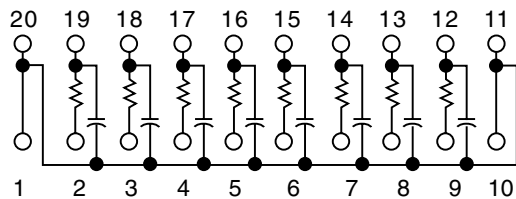

FEATURES

- Lead (Pb)-free available
- Resistors and capacitors on a single chip
- Saves board space
- Reduces total assembly costs
- Uniform performance characteristics
- Compatible with automatic surface mounting equipment
- UL 94V-0 flame resistant
- Rugged, molded case construction



TYPICAL PERFORMANCE

	TCR	TOLERANCE
RESISTOR	200	10 %
	TCC	TOLERANCE
CAPACITOR	200	20 %

VSORC	MODELS		STANDARD VALUES	
	VSSRC	VTSRC	R (Ohms)	C (pF)
	X		33	47

RC NETWORKS

STANDARD ELECTRICAL SPECIFICATIONS			
TEST		SPECIFICATIONS	CONDITION
MATERIAL		TANTALUM NITRIDE ON SILICON	
Resistance Range		10 Ohms to 750 Ohms	
TCR:	Tracking	± 10 ppm/°C	
	Absolute	± 200 ppm/°C	0 °C to + 70 °C
Tolerance:	Absolute	± 10 % Standard (R)	
	Absolute	± 20 % Standard (C)	at 1 MHz & V _{RMS} over + 10 °C to + 70 °C
Power Rating:	Package	1 W - (T)SSOP. 1.2 W - SOIC	See Derating Curve
Capacitance Range		10 pF to 150 pF - TSSOP/10 pF to 250 pF - SOIC and SSOP	
Stability:	ΔR Ratio	± 2 %	1000 hrs.
ESD Protection		> 2 kV	MIL-STD-883, Method 3015
Breakdown Voltage		35 - 50 V	
Operating Temperature Range		0 °C to + 70 °C	
Storage Temperature Range		- 55 °C to + 125 °C	
Power Rating/Resistor		100 mW	

* Pb containing terminations are not RoHS compliant, exemptions may apply



DIMENSIONS AND IMPRINTING in inches and millimeters

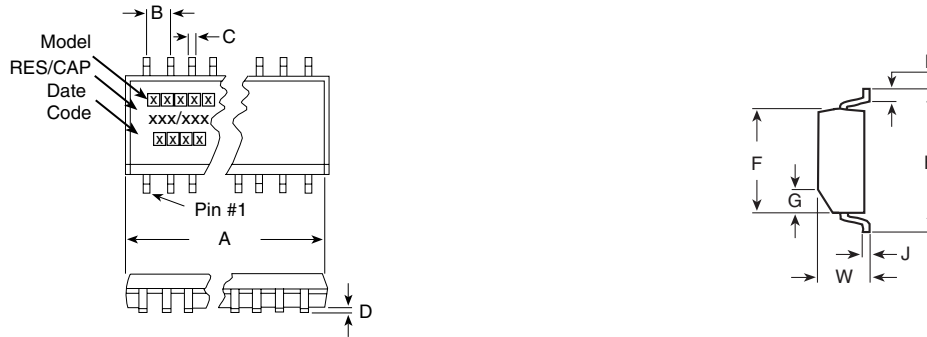

MODEL	VTSRC20-AD		VSSRC20-AD		VSORC20-AD	
	INCHES	MILLIMETERS	INCHES	MILLIMETERS	INCHES	MILLIMETERS
A	0.256 ± 0.003	6.5 ± 0.08	0.344 Max.	8.74 Max.	0.500 ± 0.010	12.7 ± 0.25
B (Ref.)	0.025	0.65	0.025	0.64	0.050	1.27
C (Ref.)	0.0087	0.22	0.010	0.25	0.016	0.41
D	0.004	0.10	0.006	0.15	0.008	0.20
E (Typ.)	0.024	0.61	0.025	0.64	0.030	0.76
F	0.173 ± 0.003	4.39 ± 0.08	0.154 ± 0.003	3.9	0.293 ± 0.003	7.44
G	0.015 × 45°	0.38	0.015 × 45°	0.38	0.025 × 45°	0.64
H	0.252 ± 0.005	6.4 ± 0.13	0.236 ± 0.008	6.0 ± 0.20	0.406 ± 0.005	10.31
J (Ref.)	0.005	0.13	0.010	0.25	0.010	0.25
W	0.043 ± 0.005	1.09 ± 0.13	0.064 ± 0.005	1.6	0.100 ± 0.005	2.59

IMPRINTING					
VSORC, VSSRC, VTSRC	20	AD	XXX / XXX		
MODEL	PIN COUNT	SCHEMATIC	RESISTANCE	/	CAPACITANCE
			Code: e.g. 100 = 10 ohm		Code: e.g. 101 = 100 pF
		XXXX Date Code			* Optional marking

MECHANICAL SPECIFICATIONS	
Resistive Element	Tantalum Nitride
Substrate Material	Silicon
Body	Molded Epoxy
Terminals	Copper Alloy
Plating	Tin Lead
Lead Coplanarity	0.0005 Inches
Marking Resistance to Solvents	Permanency testing per MIL-STD-202, Method 215
Lead (Pb)-free Option	100 % Sn Matte
Lead (Pb)-free Finish	Plated

DERATING CURVE

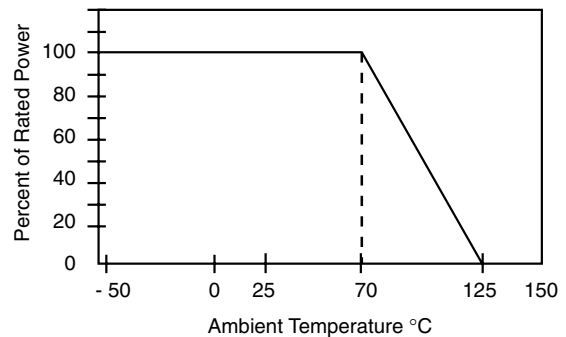

RC NETWORKS

PACKING INFORMATION			
MODEL	LEADS	TAPE AND REEL	TUBES
VTSRC (TSSOP)	20	2500	74
VSSRC (SSOP)	20	2500	55
VSORC (SOIC)	20	1000	38

VTSRC, VSSRC, VSORC-AD

Vishay Thin Film 25 or 50 Mil Pitch, T-Filter Resistor/Capacitor Networks



GLOBAL PART NUMBER INFORMATION

New Global Part Numbering: VTSRC20AD330470T1 (preferred part number format)

V T S R C 2 0 A D 3 3 0 4 7 0 T 1

GLOBAL MODEL	NUMBER OF LEADS/ SCHEMATICS	RESISTANCE & TOLERANCE/ CAPACITANCE & TOLERANCE	PACKAGING
VTSRC VSSRC VSORC (Lead (Pb)-free) (e1)	20AD	xxxxyy First 2 digits are significant figures. Last digit specifies number of zeroes to follow. K = 10 % Capacitor Tol. fixed M = 20 % Resistance Tol. fixed	UF = TUBED TAPE AND REEL TF = Full Reels

Historical Part Number example: VTSRC20AD330K470MT/R (will continue to be accepted)

VTSRC	20	AD	330K	470M	T/R
MODEL	NUMBER OF LEADS	SCHEMATIC	RESISTANCE	TOLERANCE	PACKAGING



Notice

Specifications of the products displayed herein are subject to change without notice. Vishay Intertechnology, Inc., or anyone on its behalf, assumes no responsibility or liability for any errors or inaccuracies.

Information contained herein is intended to provide a product description only. No license, express or implied, by estoppel or otherwise, to any intellectual property rights is granted by this document. Except as provided in Vishay's terms and conditions of sale for such products, Vishay assumes no liability whatsoever, and disclaims any express or implied warranty, relating to sale and/or use of Vishay products including liability or warranties relating to fitness for a particular purpose, merchantability, or infringement of any patent, copyright, or other intellectual property right.

The products shown herein are not designed for use in medical, life-saving, or life-sustaining applications. Customers using or selling these products for use in such applications do so at their own risk and agree to fully indemnify Vishay for any damages resulting from such improper use or sale.