

SP-GB-ELX



Features

- Data Rate 1.062 to 1.25 Gb/s
- Single 3.3V Supply
- 20km Reach
- 17dB Typical Link Budget
- Commercial and Industrial Temp. Operation
- 1310nm FP Laser
- Fibre Channel 100-SM-LC-L Compliant
- Gigabit Ethernet IEEE 802.3ah Compliant
- SFP MSA SFF-8074i Compliant
- Telcordia GR-468 Compliant
- Digital Diagnostic SFF-8472 Compliant
- Color Coded Bail Latch: Blue
- RoHS compliant product available

General Operation

Parameter	Symbol	Min.	Typ.	Max.	Unit
Supply Voltage	V_{CC}	3.135	3.3	3.465	V
Total Current	I_{CC}	-	-	300	mA
Power Supply Rejection ^a	PSR	100	-	-	mVp-p
Operating Case Temperature (-CXX)	T_{opr}	-5	-	70	°C
Operating Case Temperature (-TXX)	T_{opr}	-40	-	85	°C
Storage Temperature	T_{stg}	-40	-	85	°C
Data Rate GbE	DR	-	1250	-	Mbps
Data Rate FC	DR	-	1062.5	-	Mbps

a) 20Hz to 155MHz

Transmitter Specifications (Optical)

Parameter	Symbol	Min	Typical	Max	Unit
Optical Power	P_{op}	-7	-5	-0	dBm
Average Launch Power (Tx:Off)	P_{off}	-	-	-30	dBm
Extinction Ratio	ER	9	-	-	dB
Eye Mask		IEEE 802.3ah compliant			
Total Jitter	TJ	-	-	200	ps
Optical Rise Time ^b	t_r	-	-	260	ps
Optical Fall Time ^b	t_f	-	-	260	ps
Mean Wavelength	λ	1270	1310	1355	nm
Spectral Width (RMS)	$\Delta\lambda$	-	-	4	nm
Optical Path Penalty at 20 km	dp		1	2	dB
Relative Intensity Noise	RIN	-	-	-120	dB/Hz

b) 20%-80% values

SP-GB-ELX

Transmitter Specifications (Electrical)

Parameter	Symbol	Min	Typical	Max	Unit
Input Differential Impedance	R_{in}	80	100	120	Ω
PECL Single Ended Data Input Swing	$V_{in, p-p}$	250	-	1200	mV
TxFault_Fault	V_{fault}	2	-	V_{cc}	V
TxFault_Normal	V_{normal}	V_{ee}	-	$V_{ee} + 0.5$	V
TxDisable_Disable	V_d	2	-	V_{cc}	V
TxDisable_Enable	V_{en}	V_{ee}	-	$V_{ee} + 0.8$	V

Receiver Specifications (Optical)

Parameter	Symbol	Min	Typical	Max	Unit
Receiver Power Low ^c	$R_{sens,low}$	-	-26	-24	dBm
Receiver Power High ^c	$R_{sens,high}$	-3	0	-	dBm
Damage Threshold for Receiver	$P_{in, damage}$	6	-	-	dBm
Wavelength ^d	λ	1270	-	1355	nm
Maximum Reflectance of Receiver	RX_r	-	-	-12	dB
LOS Assert	-	-38	-	-	dBm
LOS De-Assert	-	-	-	-24	dBm
LOS Hysteresis	-	0.5	-	-	dB

c) Measured at BER of 10^{-12} , PRBS of 2^7-1 , at eye center

d) Operational over 1200-1625nm range

Receiver Specifications (Electrical)

Parameter	Symbol	Min	Typical	Max	Unit
PECL Single-Ended Data Output Swing	$V_{out,p-p}$	185	-	800	mV
Data Output Rise Time	t_r	-	-	260	ps
Data Output Fall Time	t_f	-	-	260	ps

SP-GB-ELX

Timing and Electrical

Parameter	Symbol	Min	Typical	Max	Unit
Tx Disable Negate Time	t_on	-	-	1	ms
Tx Disable Assert Time	t_off	-	-	10	μs
Time to Initialize, Including Reset of Tx Fault	t_init	-	-	300	ms
Tx Fault Assert Time	t_fault	-	-	100	μs
Tx Disable to Reset	t_reset	10	-	-	μs
LOS Assert Time	t_loss_on	-	-	100	μs
LOS De-assert Time	t_loss_off	-	-	100	μs
Serial ID Clock Rate	f_serial_clock	-	-	100	KHz
RX_LOS Voltage (high)	Rx_LOS _H	2	-	V _{CC}	V
RX_LOS Voltage (low)	RX_LOS _L	-	-	0.8	V
LOS Output Voltage-Fault	V _{LOS} fault	2	-	V _{CC}	V
LOS Output Voltage-Normal	V _{LOS} normal	V _{EE}	-	V _{EE} + 0.5	V
MOD_DEF (0:2)-High	V _H	2	-	V _{CC}	V
MOD_DEF (0:2)-Low	V _L	V _{EE}	-	V _{EE} + 0.55	V

Diagnostics

Parameter	Range	Accuracy	Unit	Calibration	Formula
Temperature (-CDx)	-5 to 70	±3	°C	Internal	Tc(C) = Tad(16 bit signed twos complement)/256
Temperature (-TDx)	-40 to 85	±3	°C	Internal	Tc(C) = Tad(16 bit signed twos complement)/256
Voltage	0 to V _{CC}	0.1	V	Internal	V(Volts) = Vad(16 bit unsigned integer)*0.1
Bias Current	0 to 120	5	mA	External	I(mA) = Islope * lad(16 bit unsigned integer)+loffset
Tx Power	-7 to 0	±3dB	dBm	External	Tx_PWR(μW) = Tx_PWRslope*T _x _PWRad(16 bit unsigned integer)+Tx_PWRoffset
Rx Power	-24 to -3	±3dB	dBm	External	Rx_PWR(μW) = A0+A1*x+A2*x ² +A3*x ³ +A4*x ⁴

SP-GB-ELX

EEPROM Serial ID				
Name of Field	Description of Field	Address	Hex	ASCII
Vendor Name	SFP Vendor name (ASCII)	20	4C	L
		21	55	U
		22	4D	M
		23	49	I
		24	4E	N
		25	45	E
		26	4E	N
		27	54	T
		28	4F	O
		29	49	I
		30	43	C
Vendor OUI	IEEE vendor OUI code for LuminentOIC Inc.	37	00	
		38	06	
		39	B5	
Vendor P/N	Part number in ASCII, e.g. SP-GB-ELX-CDA	40	53	S
		41	50	P
		42	47	G
		43	42	B
		44	45	E
		50	4C	L
		51	58	X
		52	43	C
		53	44	D
54	41	A		

SP-GB-ELX

Pinout Definitions

Pin	Function	Notes
1	V _{ee} T	TX GND
2	TX_FAULT	Open Collector
3	TX_DISABLE	Internally Pulled High
4	MOD_DEF2	Serial Data Input
5	MOD_DEF1	Serial Clock Input
6	MOD_DEF0	Internally Grounded
7	NC	Not Connected
8	LOS	Open Collector
9	V _{ee} R	RX Ground
10	V _{ee} R	RX Ground
11	V _{ee} R	RX Ground
12	RXD-	RX Data Negative
13	RXD+	RX Data Positive
14	V _{ee} R	RX GND
15	V _{CC} R	RX Power
16	V _{CC} T	TX Power
17	V _{ee} T	TX GND
18	TXD+	TX Data Positive
19	TXD-	TX Data Negative
20	V _{ee} T	TX GND

Outline Drawing

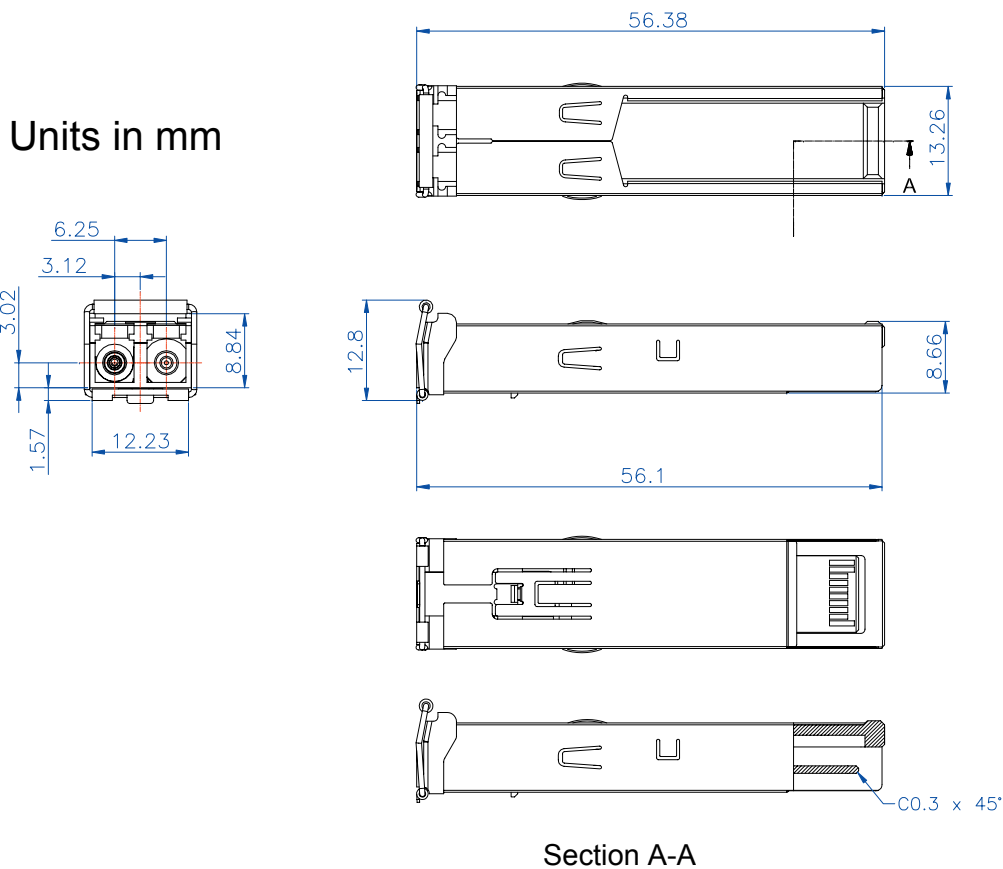

SP-GB-ELX

Suggested Transceiver interface

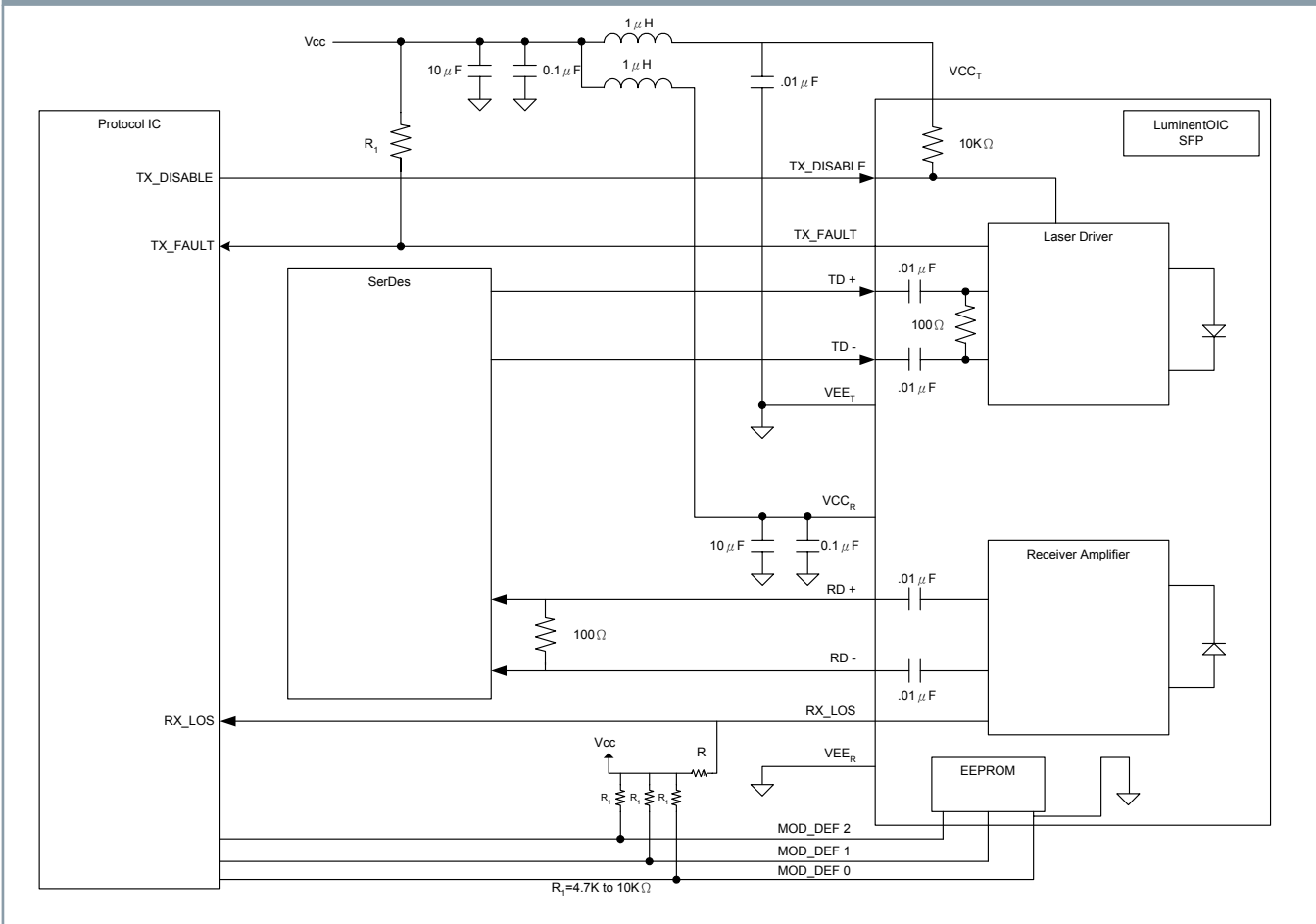

SP-GB-ELX

Ordering Information

Available Options:

- SP-GB-ELX-CNA SP-GB-ELX-CNB
- SP-GB-ELX-CDA SP-GB-ELX-CDB
- SP-GB-ELX-CNA SP-GB-ELX-CNB
- SP-GB-ELX-CDA SP-GB-ELX-CDB

Part numbering Definition:

SP - GB - ELX - Temperature Diagnostic Revision - Customer Specific

- **SP = Small Form Pluggable**
GB = 1.25Gbps
ELX = IEEE 802.3z Interface 20km
- **C = Commercial (-5 to 70°C)**
T= Industrial temperature (-40 to 85°C)
- **D = Diagnostic**
N = No Diagnostic
- **Revision**
A = RoHS 5/6-compliant product (lead exemption)
B = Full RoHS compliant product (no exemption)
- **Blank = Standard Procedure**
Labelling, Serial number, or Shipping Instructions, etc.

Warnings:

Handling Precautions: This device is susceptible to damage as a result of electrostatic discharge (ESD). A static free environment is highly recommended. Follow guidelines according to proper ESD procedures.
Laser Safety: Radiation emitted by laser devices can be dangerous to human eyes. Avoid eye exposure to direct or indirect radiation.

Legal Notes:

IMPORTANT NOTICE!
 All information contained in this document is subject to change without notice, at LuminentOIC’s sole and absolute discretion. LuminentOIC warrants performance of its products to current specifications only in accordance with the company’s standard one-year warranty; however, specifications designated as “preliminary” are given to describe components only, and LuminentOIC expressly disclaims any and all warranties for said products, including express, implied, and statutory warranties, warranties of merchantability, fitness for a particular purpose, and non-infringement of proprietary rights. Please refer to the company’s Terms and Conditions of Sale for further warranty information.

LuminentOIC assumes no liability for applications assistance, customer product design, software performance, or infringement of patents, services, or intellectual property described herein. No license, either express or implied, is granted under any patent right, copyright, or intellectual property right, and LuminentOIC makes no representations or warranties that the product(s) described herein are free from patent, copyright, or intellectual property rights. Products described in this document are NOT intended for use in implantation or other life support applications where malfunction may result in injury or death to persons. LuminentOIC customers using or selling products for use in such applications do so at their own risk and agree to fully defend and indemnify LuminentOIC for any damages resulting from such use or sale.

THE INFORMATION CONTAINED IN THIS DOCUMENT IS PROVIDED ON AN “AS IS” BASIS. Customer agrees that LuminentOIC is not liable for any actual, consequential, exemplary, or other damages arising directly or indirectly from any use of the information contained in this document. Customer must contact LuminentOIC to obtain the latest version of this publication to verify, before placing any order, that the information contained herein is current.

© LuminentOIC, Inc. 2003
 All rights reserved