

F9J GCBH

BC HG
% 7 F9DF9G9BHG5 7F#H7 5@8A 9BGCB"
&"6l FF 5@K 5B79."\$\$ OS, OA 5L"
!"D5FHGC 69A C@898 HC DC G#C B"
("A B A I A D B DI @C I H: C F 7 9.) "\$\$\$@Q&&(BQ
)"7 C BH57 HA I GH69 B G9FH98 I BH@F9#BHC B: 95H F9@C 7?G#HC D@579"
*"5@: B@<98: C C 8G5F9HC 69@M9F D5775; 98 B G@#DB; "
+:"CB@M5J 5@6@B HB D@5HB; "
⑦ "5@D5FHGC D5GG9@7 HF 7 5@H9HI DC B 5GG9A 6@M
"fB7 @ 8 B: < DC H#GH5H%\$\$ J C @G87 L"5: HF : B 5@9@7 HF 7 5@H9H#
"@69@957 < 5GG9A 6@M#K #: %@69@9H
:"5DD@7 5HC BG#J C @ B: G9J 9F96988B; F9E I #9**A B A I A 756@9B; H#"
% "89@9H8"
% "89@9H8"
%&"I&\$ 1 G9G&\$: 5: 9' \$\$ J C @H7 56@9"
% "5J 5@6@9 C B @M5G5B 5GC "
% ("I&\$*1 G9G&\$: 5: 9* \$\$ J C @H7 56@9"
%) "A B A I A 9#B@5H7 < F9#BHC B: C F 7 9. %\$\$\$@Q(") BQ
%": C F 7 F A D 8 A 9BGC BGG98K @%\$LLLLL!LL"LLLL!LL: C F DJ 7
.....5DD@7 5HC BGC F 8K @!\$%LLLLL!LL"LLLL!LL: C F: 9D 5DD@7 5HC B G"
%": C F @B: H#G@GGH#5B %& B ZHC @F5B7 9G<5@69 -& "
.....69~%&) O % Q: C F C H 9F @B: H#G@HC @F5B7 9G<5@69 -& "
% "5J 5@6@9HC 9L@HB; 7I GHA 9FGCB@ZBC BHC89@ B 5GC: F9J GCB D"

DA G8L!LL!LLLL!LL!LL"LL!L!LLL

: 9D 7 56@C DHC B
!H: 9D
f@5J 96@B?: C F G#B85F8
DJ 7 B G @5HC B L
Bc C: DC G#C BG
!\$& H#F I 1@
fD9F F C K L
K #9: 5I: 9f5K: L
H DJ 7 .!% z1% z1!&* z1!&\$ z1!&z1!&(
: 9D .!% z1! !&(
7 C @ F 7 C 8 9
@5J 96@B?: C F 5@6@57? K #9
7: 7 C @ F 7 C 8 98 K #92G997 C @ F
.....G9E I 9B 7 9H56@ZG< 99H"
fBC H5J 5@6@K #: 9D C DHC B L
@58 GH@9
!GD. G#B85F8 DC K 9F f7!% -!LL!GD!H
!<D.<#< DC K 9F f7!% -!LL!<D!H
.....fG99BC H9% L

C DHC B
GB: @
IA 9#B@5H7 < fI G9#D68!LL!8!A L
.....@5J 96@B?: C F D@5GH7 L
8C I 6@9
!@ G D@5GH7 @5H7 < I DZGHF5# <H
!@G D@5GH7 @5H7 < 8C K BZGHF5# <H
!@ L D@5GH7 @5H7 < I DZ7 FC G98
!@L D@5GH7 @5H7 < 8C K BZ7 FC G98
!A I G A 9#B@5H7 < I DZGHF5# <H
!A 8G A 9#B@5H7 < 8C K BZGHF5# <H
!A I L A 9#B@5H7 < I DZ7 FC G98
!A 8L A 9#B@5H7 < 8C K BZ7 FC G98
9B8 C DHC B
!G GB: @9B8
!8: 8C I 6@9B8
.....fA I GH7 < C C G9@ G@G@L Z@LZ
.....A I G A 8G A I L Z C F A 8L
H H B C H F 9@5G98: C F DFC 8I 7 H C B

8C BCH
G75@: FCA
H#GDFBH

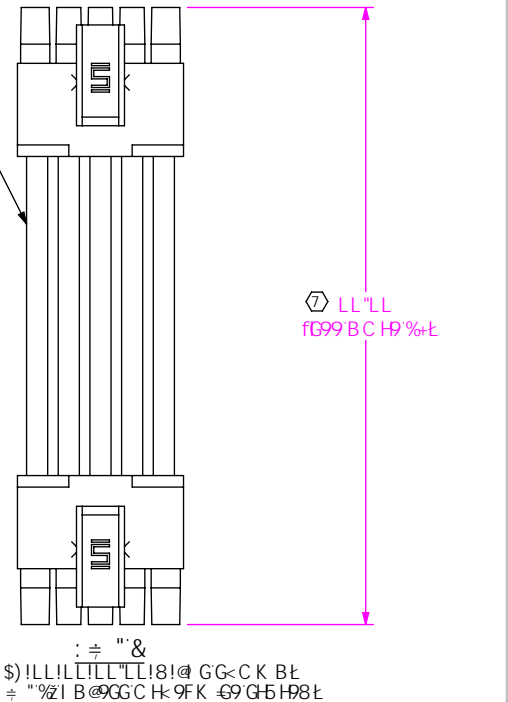
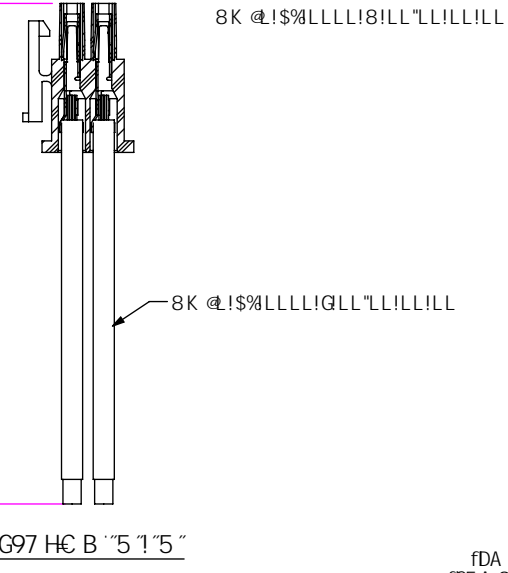
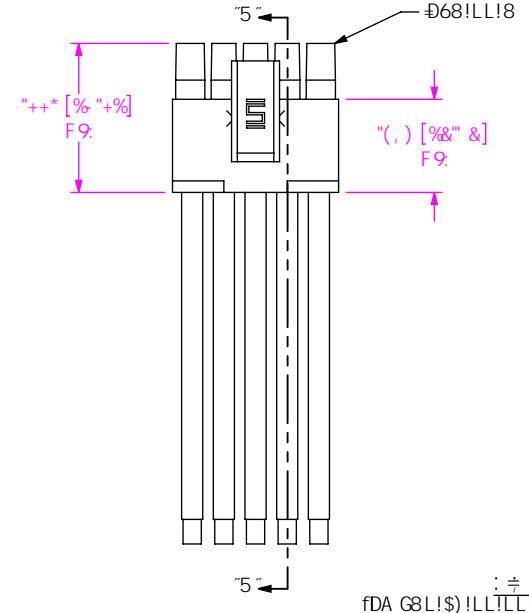
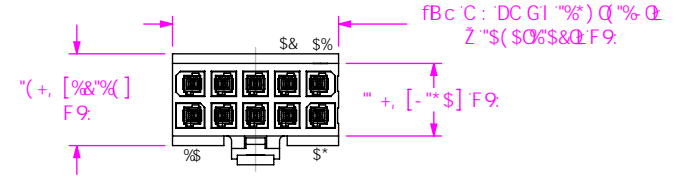

I G99BC H9G%&L / %
H G99BC H9%L

TABLE 1

SERIES	CABLE AWG	CABLE	CONTACT
PMSD	16 AWG	DWC-16-10-600	C-169-03-XX-T
PMSD	18 AWG	DWC-18-10-600	C-169-03-XX-T
PMSD	**206 AWG	DWC-20-10-600	C-169-03-XX-T
PMSD	*203 AWG	DWC-20-10-300	C-169-02-XX-T
PMSD	22 AWG	DWC-22-10-300	C-169-02-XX-T
PMSD	24 AWG	DWC-24-10-300	C-169-02-XX-T
PMSDT	18 AWG	DWCT-18-01	C-169-03-XX-T
PMSDT	24 AWG	DWCT-24-01	C-169-04-XX-T

1 BCH F 9@5G98: C F DFC 8I 7 H C B
WPYbH f@f@j UI 1PBK: PA @7 PA ?H PDA G8L!LL!LLLL!LL!LL"LL!L!LLIA ?HG@88FK

I B @GG C H 9FK @9 GD97 @98Z
8A 9BGC BG5F9 B B7 < 9G"
HC @F5B7 9G 5F9.
897 A 5@G5B: @G
"LL ± "\$% O"& *
"LLL ± "\$% O"& *
"LLLL ± "\$% OS) %Q

A 5HF 5@ 8C BCH G75@ 8F5K B: G 99HG 75@ % % 8967 F @HC B.
<C I GB; 7 J 5 @ L () + 27 C @ F. B5H F5 @
7 C B5 7 H D C G 6 F C B N 9
7 56@ / B G @5HC B. G99 7 5 @ C I H
.....K #9. G99 7 5 @ DF B H B C H @58: F 99L
A 9#B@5H7 < . B 7 9 @ D@5H8 6Y7 I Z. &) Z % # & < H

DFC DF 9H5 F M B C H 9
H: G8C 71A 9B H 7 C B H 8 G B: CFA 5HC B
7 C B: 89B H 5 @5B8 DFC DF 9H5 F M C
G5A H 7 Z 4 7 * 5B8 G 5 @ B C H 9 F 90FC 8I 7 98
C F H 5 B G 9 F 98 H C C H 9 F 8 C 7 I A 9B H G C F
8 47 @ C 98 H C C H 9 G C F I 98: C F 5 B M
DI FDC 9 C H 9 F H 5 B H 5 H K < 7 < H K 5 G
C 6 H 8 98 K # C I H H 9 9 L D F 9 G 98 K F H 98
7 C B G 98 H C: G5A H 7 Z 4 7

samtec
&\$ D5F? 95GH6@ 8ZB9K 5@5B M B (+) %
> < C B 9; %& - ((! * + 5L; %& - () \$ (+
YIA UJ; 7z 4 G5A H7 Wca W@XY.)') &&
8K: "BC"
DA G8L!LL!LLLL!LL!LL"LL!L!LLL
6M 895 B D \$+ #, #&\$ \$ (G< 99H % C: '

