

Bantam Plus DSX-1/1C System Patch Cords and Accessories

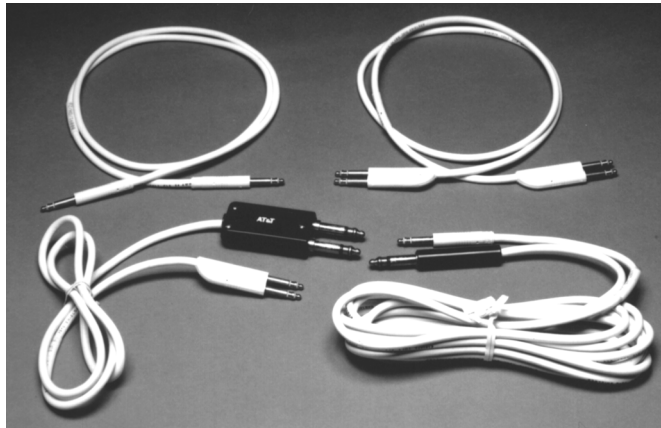

Bantam Plus Simplex and Duplex Standard and Hybrid Patch Cords

Description

The Bantam Plus – Digital Signal Cross-Connect-1/1C (DSX-1/1C) System patch cords consist of a family of standard and hybrid offerings. The term standard refers to cords having bantam-type plugs, either single or duplex, on both ends. The term hybrid refers to cords having a bantam-type plug on one end and a different plug, either 800-type or 310-type (long-frame) on the other end.

There is also a new family of cords available called the DS-1 Cross-Connect Regenerator Cords. These cords boost the -20 dB DS-1 monitor signal level by 20 dB to produce a standard DS-1 signal level. This feature allows DS-1 circuits from DSX equipment, including Bantam Plus – DSX System, to be bridged to other DSX equipment while the circuit is in service.

The cord configurations available are as follows:

- Standard bantam-to-bantam
- Hybrid bantam-to-800-type
- Hybrid bantam-to-310 (long-frame)
- 800-type-to-bantam regenerator
- Bantam-to-800-type regenerator
- Bantam-to-bantam regenerator.

Patch Cord Specifications

Electrical and Transmission

- Meets UL requirements for telephone circuits operating at 100 mA or less and a maximum of 56.5 V DC with a ring voltage not exceed 150 V rms
- Impedance: 100 ohms

- Attenuation: 0.025 dB/ft at DS-1 rate
- Return Loss: equal to or greater than 26 dB for patch cords (12 feet [3.7 m]) long or less.

Mechanical

- Bantam-Type Plugs: brass, 0.173 in. (4.4 mm) diameter
- Conductor: 24 AWG (0.51 mm) solid copper
- Outer Jacket: White flame-retardant PVC (bantam-to-bantam

and bantam-to-310 configurations)

- Minimum breaking or connector pull-off strength: 65 lbs. (289 N) for the standard bantam-to-bantam configurations

Environmental

- Operating Temperature: -40°F/C to +185°F (85°C)
- Humidity: 0 to 95 percent



Standard Bantam-to-Bantam Cords

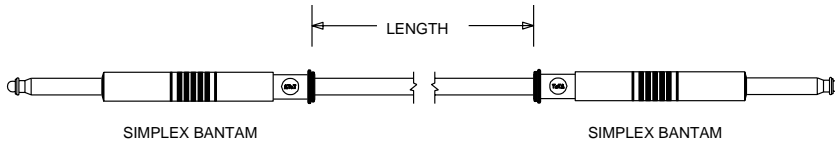

Standard Simplex Bantam Patch Cord

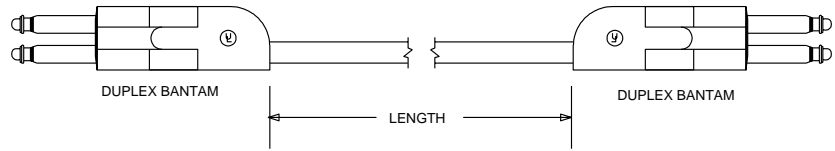

Standard Duplex Bantam Patch Cords

The Bantam Plus - DSX System uses either simplex or duplex standard cords. These cords are compatible with other manufacturers' panels using bantam-type jacks. Cords use three-conductor plugs with single plug cords using two-conductor shielded cable and dual (duplex) plug cords using four-conductor shielded cable with plug sleeves common. Cords are PVC jacketed and plugs are overmolded onto cables. Cable and overmolding color is white on the bantam-to-bantam cords. The patch cords are capable of connecting both DS1 and DS1C signals.

Duplex cords are wired straight ; thus, to connect the OUT jack of one DSX to the IN jack of another DSX requires rotating (flipping) the orientation of the duplex plugs at one end of the cord relative to the plug at the opposite end.

For other lengths, contact your Lucent Technologies Account Representative.

Ordering Information

Apparatus Code	Description	Comcode
<i>Simplex Patch Cords</i>		
DSX1P1A-01-BNP	1-foot (0.3 m) simplex bantam patch cord	106 578 321
DSX1P1A-03-BNP	3-foot (0.9 m) simplex bantam patch cord	106 578 503
DSX1P1A-06-BNP	6-foot (1.8 m) simplex bantam patch cord	106 578 511
DSX1P1A-12-BNP	12-foot (3.7 m) simplex bantam patch cord	106 578 529
DSX1P1A-25-BNP	25-foot (7.6 m) simplex bantam patch cord	106 578 537
DSX1P1A-50-BNP	50-foot (15.2 m) simplex bantam patch cord	106 578 545
<i>Duplex Patch Cords</i>		
DSX1P2A-01-BNP	1-foot (0.3 m) duplex bantam patch cord	106 578 552
DSX1P2A-03-BNP	3-foot (0.9 m) duplex bantam patch cord	106 578 560
DSX1P2A-06-BNP	6-foot (1.8 m) duplex bantam patch cord	106 578 578
DSX1P2A-10-BNP	10-foot (3.0) duplex bantam patch cord	108 174 236
DSX1P2A-12-BNP	12-foot (3.7 m) duplex bantam patch cord	106 578 586
DSX1P2A-15-BNP	15-foot (4.6 m) duplex bantam patch cord	108 174 269
DSX1P2A-20-BNP	20-foot (6.1 m) duplex bantam patch cord	108 174 269
DSX1P2A-25-BNP	25-foot (7.6 m) duplex bantam patch cord	106 578 594
DSX1P2A-50-BNP	50-foot (15.2 m) duplex bantam patch cord	106 578 644

DS1, CEPT-1, and CEPT2

Bantam Plugs

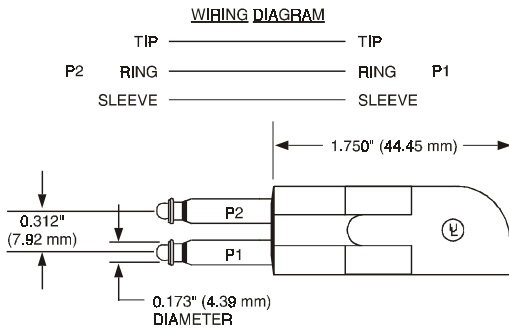

LOOPING PLUG - WHITE
(106 578 693)

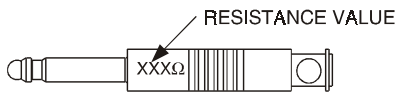

TERMINATING PLUG
(SEE TABLE FOR RESISTANCE VALUES AND COMCODES)

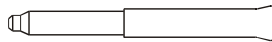

DUMMY PLUG - BLACK
(106 578 685)

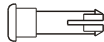

CIRCUIT GUARD PLUG
(SEE TABLE FOR COMCODES AND COLORS)

Accessory plugs for the Bantam Plus - DSX System include terminating, dummy, looping, and circuit guard plugs.

For testing of digital equipment prior to cutover, a looping plug loops the OUT circuit to the IN.

A terminating plug is used to provide a resistive load on a digital circuit, typically during testing or maintenance patching. Four resistor values are available. The 100-ohm terminating plug is intended to terminate DS1/1C circuits. The 135-ohm, 60-ohm, and 900-ohm terminating plugs are intended for voice-frequency circuits and are not usually needed with the DSX system.

A dummy plug, when inserted, opens the normally closed contacts within the bantam jack and is useful during transition procedures where it is desirable to prerun cross-connects without causing long Y-splices.

Circuit guard plugs are plastic, snap-in jack caps that block access to the OUT, IN, or MON circuit jacks. They are used to prevent the inadvertent interruption of service that could be caused by inserting a plug into the OUT or IN jack positions. Circuit guard plugs are available in red, black, or white.

Ordering Information

Code	Description	Comcode
DSXITP1-100BNA	100-ohm terminating plug	106 578 651
DSXITP1-135BNA	135-ohm terminating plug	106 588 486
DSXITP1-600BNA	600-ohm terminating plug	106 588 510
DSXITP1-900BNA	900-ohm terminating plug	106 588 551
DSX1DP1-BLKBNA	Black Dummy Plugs (Package of ten)	106 578 685
DSX1LP1-WHTBNA	White Looping Plug	106 578 693
DSX1CG1-REDBNA	Red Circuit Guard Plugs (Package of ten)	106 578 701
DSX1CG1-BLKBNA	Black Circuit Guard Plugs (Package of ten)	106 588 569
DSX1CG1-WHTBNA	White Circuit Guard Plugs (Package of ten)	106 588 577

Accessory Plug Coding

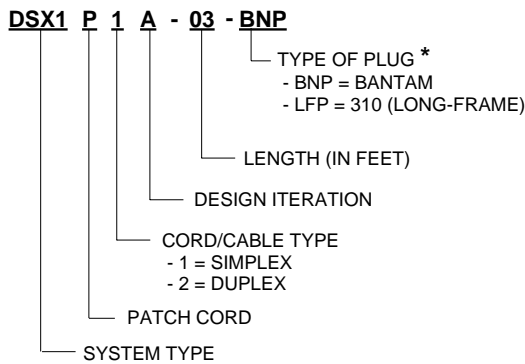

* - Type of plug on one end of patch cord. Opposite end has a bantam-type plug.

Hybrid Patch Cords—Bantam-to-800-Type

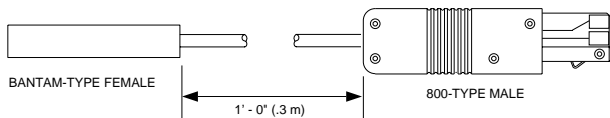

1-Foot Single Bantam-Type Female to 800-Type Male Patch Cord (800F/1)

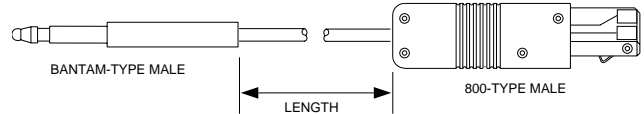

Bantam-Type Single Male to 800-Type Single Male Patch Cord (800H/Length)

Ordering Information

Patch cords are available to patch between a bantam-type jack and an 800-Series or 900-Series DSX jack or DIXI-1 DSX jack.

Apparatus Code	Description	Comcode
800/F1	1-foot (0.3 m) patch cord, bantam-type single female to 800-type single male	104 366 893
800H/12	12-foot (3.7 m) patch cord, bantam-type single male to 800-type single male	104 366 927

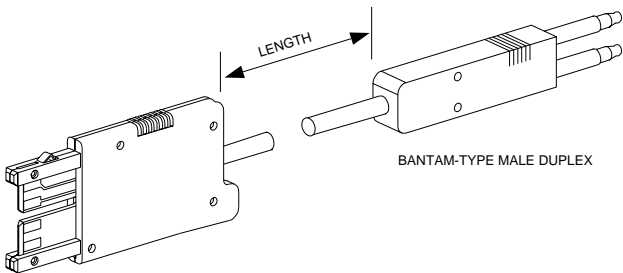

WHITE 800-TYPE MALE DUPLEX

800-Type Male Duplex to Bantam-Type Male Duplex Patch Cord (800HD/Length)

Ordering Information

Ordering information for the 800-Type-to-Bantam hybrid duplex patch cords is provided below. See 365-301-120 for information on the 800-Series and 900-Series DSX Systems, or 365-301-121 for the DIXI-1 System

Apparatus Code	Description	Comcode
800HD/3	3-foot (0.9 m) patch cord, 800-type male duplex to bantam-type male duplex	105 774 012
800HD/6	6-foot (1.8 m) patch cord, 800-type male duplex to bantam-type male duplex	105 774 020

Apparatus Code	Description	Comcode
800HD/12	12-foot (3.7 m) patch cord, 800-type male duplex to bantam-type male duplex	105 774 038
800HD/25	25-foot (7.6 m) patch cord, 800-type male duplex to bantam-type male duplex	105 774 046
800HD/50	50-foot (15.2 m) patch cord, 800-type male duplex to bantam-type male duplex	105 774 053

Hybrid Patch Cords—Bantam-to-310 (Long-Frame)

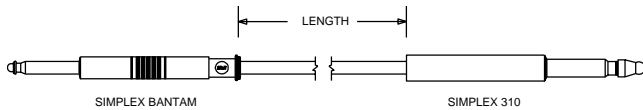

12-Foot Bantam-Type Simplex to 310-Type Simplex Patch Cord

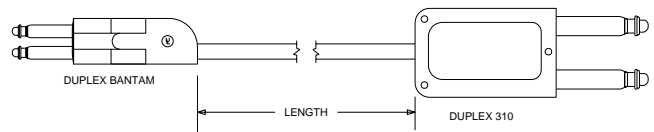

Bantam-Type Duplex to 310-Type Duplex Patch Cord

Ordering Information

Patch cords are available to patch between bantam-type jacks and 310-type jacks (long frame). The 310-type jacks are often found on obsolete DSX-1/1C panels, such as ED-1C544-30 or ED-2C544-30 panels.

Apparatus Code	Description	Comcode
DSX1P1A-25-LFP	10-foot (3.0 m) bantam-type simplex to 310-type simplex patch cord	106 678 519
DSX1P1A-12-LFP	12-foot (3.7 m) bantam-type simplex to 310-type simplex patch cord	106 700 875
DSX1P2A-03-LFP	3-foot (0.9 m) bantam-type duplex to 310-type duplex patch cord	106 700 891
DSX1P2A-05-LFP	5-foot (1.5 m) bantam-type duplex to 310-type duplex patch cord	108 174 319
DSX1P2A-06-LFP	6-foot (1.8 m) bantam-type duplex to 310-type duplex patch cord	106 700 909
DSX1P2A-10-LFP	10-foot (3.0 m) bantam-type duplex to 310-type duplex patch cord	108 174 335
DSX1P2A-12-LFP	12-foot (3.7 m) bantam-type duplex to 310-type patch cord	106 700 917
DSX1P2A-15-LFP	15-foot (4.6 m) bantam-type duplex to 310-type patch cord	106 991 433
DSX1P2A-20-LFP	20-foot (6.1 m) bantam-type duplex to 310-type patch cord	108 174 368
DSX1P2A-25-LFP	25-foot (7.6 m) bantam-type duplex to 310-type patch cord	106 991 441
DSX1P2A-30-LFP	30-foot (9.1 m) bantam-type duplex to 310-type patch cord	108 178 120
DSX1P2A-40-LFP	40-foot (12.2 m) bantam-type duplex to 310-type patch cord	108 174 400
DSX1P2A-50-LFP	50-foot (15.2 m) bantam-type duplex to 310-type patch cord	107 041 840
DSX1P2A-75-LFP	75-foot (22.9 m) bantam-type duplex to 310-type patch cord	108 174 418

Miscellaneous Accessory Kits

The miscellaneous cord and plug kit (DSX1MAK1-1A-BNA, Comcode 106 727 860) includes commonly used Bantam Plus - DSX System patch cords, plugs, and circuit guards. The "soak kit" (DSX1MAK1-1A-BLP, Comcode 107 995 110) consists of a total of 29 patch cords, used to assist in a soak test for a DS1-DS3

multiplexer.

Note: Additional kits can be developed upon request. Contact your local account representative or call 1-800-344-0223, ext. 3122, for additional information.

Ordering Information

Apparatus Code	Comcode	Description
<i>Miscellaneous Accessory Kit—DSX1MAK1-1A-BNA—Comcode 106 727 860</i>		
DSXITP1-100BNA	106 578 651	100-ohm Terminating Plug – Qty. four

Apparatus Code	Comcode	Description
DSXITP1-600BNA	106 588 510	600-ohm Terminating Plug – Qty. one
DSXITP1-900BNA	106 588 551	900-ohm Terminating Plug – Qty. one
DSX1LP1-WHTBNA	106 578 693	White Looping Plug – Qty. four
DSX1DP1-BLKBNA	106 578 685	Black Dummy Plug – Qty. one pkg. of ten
DSX1CG1-REDBNA	106 578 701	Red Circuit Guard – Qty. one pkg. of ten
DSX1P1A-01-BNP	106 578 321	1-foot (0.3 m) simplex patch cord – Qty. two
DSX1P2A-01-BNP	106 578 552	1-foot (0.3 m) duplex patch cord – Qty. two
DSX1P1A-03-BNP	106 578 503	3-foot (0.9 m) simplex patch cord – Qty. two
DSX1P2A-03-BNP	106 578 560	3-foot (0.9 m) duplex patch cord – Qty. two
DSX1P1A-06 BNP	106 578 511	6-foot (1.8 m) simplex patch cord – Qty. two
DSX1P2A-06-BNP	106 578 578	6-foot (1.8 m) duplex patch cord – Qty. two
DSX1P1A-12-BNP	106 578 529	12-foot (3.7 m) simplex patch cord – Qty. two
DSX1P2A-12-BNP	106 578 586	12-foot (2.7 m) duplex patch cord – Qty. two
DSX1P1A-12-LFP	106 700 875	12-foot (3.7 m) bantam simplex to 310 simplex patch cord – Qty. two
DSX1P2A-12-LFP	106 700 917	12-foot (3.7 m) bantam duplex to 310 duplex patch cord – Qty. two
<i>DS-1/IC "Soak Kit"—DSX1MAK1-1A-BLP—Comcode 107 995 110</i>		
DSX1P1A-01-BNP	106 578 321	1-foot (0.3 m) simplex patch cord – Qty. 27
DSX2P1A-06-BNP	106 578 511	6-foot (1.8 m) simplex patch cord – Qty. two

DS1 Regenerator Cords

The DS1 cross-connect regenerator cords are a family of hand-held regenerators for DS1-type signals. These cords boost the -20 dB DS1 monitor signal level by 20 dB to produce a standard DS1 signal level. This allows DS1 circuits to be bridged while the circuit is in-service.

Each regenerator cord assembly consists of a 4-foot (1.2 m) input cord and plug, a 3.8-inch long by 2.4-inch wide by 0.9-inch deep (97 mm by 51 mm by 23 mm) regenerator unit, and either a 30-foot (9 m) or 60-foot (18 m) output cord and plug. There are two configurations of regenerator cords available:

- 800-Type-to-Bantam – 800-type input to bantam-type output
- Bantam-to-Bantam—Bantam-type input to bantam-type output.

Each regenerator unit has three Light-Emitting Diodes (LEDs) located on the front of the box to assist with diagnostics. The green POWER LED lights when power is applied. The green SIGNAL PRESENT LED lights when a signal is present at the regenerator's input. The yellow BPV LED lights when bipolar violations (bit

errors) are detected in the bit stream.

The input cord plugs into the monitor (MON) jack of a DSX circuit. When the output cord is plugged into the IN jack of a second DSX circuit, the signal from the first DSX circuit is bridged to the second DSX circuit.

Power for the regenerator cords is provided by one of two methods, depending on the type of plug (800-type or bantam-type) used for the input. The cords with an 800-type input plug receive -48 V from the MON jack of the 800A-type jack block. The cords with a bantam-type input plug receive their power via an additional cord equipped with a plug that slides onto any available power/ground wire-wrap pins (for example, a connecting block that is wired to a Fuse and Alarm Panel).

The regenerator cords equipped with an 800-type output plug contain a 100-ohm resistor for terminating cross-connect circuits. Cords equipped with a bantam-type output plug will not automatically terminate the cross-connect circuits.

800-Type-to-Bantam Regenerator Cords

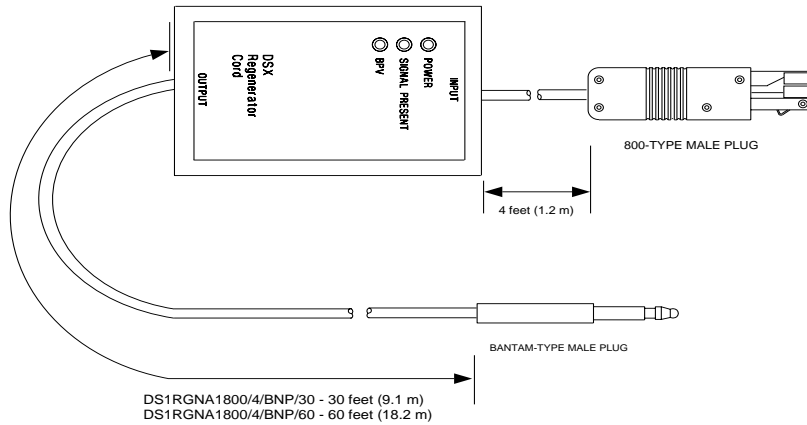

800-Type-to-Bantam Regenerator Cord

The 800-Type-to-Bantam regenerator cords are equipped with an 800-type plug at the input end and a bantam-type plug at the output end. The cords are used to bridge a DS1 circuit from an 800A-type jack block to a bantam panel.

Ordering Information

Apparatus Code	Description	Comcode
DS1RGNA1800/4/BNP/30	30-foot (9.1 m) cord, 800-type input, bantam-type output	106 982 432
DS1RGNA1800/4/BNP/60	60-foot (18.2 m) cord, 800-type input, bantam-type output	107 050 353

Bantam-to-Bantam Regenerator Cords

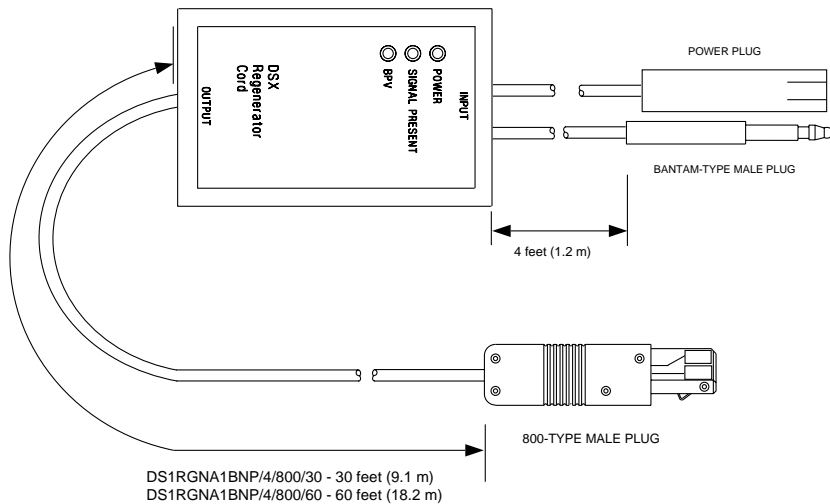

Bantam-to-Bantam Regenerator Cord

The Bantam-to-Bantam regenerator cord is equipped with a bantam-type plug and power plug at the input end and a bantam-type plug at the output end. The cord is used to bridge a DS1 circuit from one bantam panel to another bantam panel.

Ordering Information

Apparatus Code	Description	Comcode
DS1RGNA1BNP/4/BNP/30	30-foot (9.1 m), bantam-type input, bantam-type output regenerator cord	106 982 424



Jumper Wire

The recommended cross-connect wire for use with the Bantam Plus – DSX System is five-conductor Y2-type wire. This wire consists of two pairs (one for each direction of transmission) and a fifth wire for cross-connecting the tracing lamp circuits. The wire has tinned, 24-gauge (0.51 mm), dual-insulated conductors, with irradiated PVC over semirigid PVC, for excellent toughness and

transmission characteristics. It is available either on spools or coils.

For cross-connections requiring a single pair, use two-conductor Y1-type wire. For example, when cross-connecting a maintenance line to a Quasi-Random Signal Source (QRSS) fanout circuit.

Ordering Information

Code	Description	Comcode
Y2-5C/24 S660	Five-conductor, 660-foot spool, four per box	105 271 209
CCW-P 1/24 S/1000	One pair, 1,000-foot spool	102 590 791

Cables

Two families of cable are recommended for connecting circuits to the DSX: the 1249C Series and the 600C Series.

1249C Cable

The 1249C is 26 AWG (0.40 mm) twisted pair with dual solid PE/PVC insulation, an inner jacket or buffer, a dual aluminum-foil shield with solid 24 AWG (0.51 mm) drain wire, and a PVC jacket. The cable is recommended for all cable runs to the DSX up to 450 feet (137 m) and cross-aisle tie circuits between DSX lineups. Space saving advantages are so significant, that with the 25 pair, eight cables will fit into about the same space as four of the 600C with foil shield or three of the earlier 600B with corrugated aluminum shield. The 1249C Series cable is lighter weight and

easier to handle than either of the 600 Series. The transmission characteristics include attenuation of 6.5 dB/1,000 feet (305 m) at 772 KHz and characteristic impedance of 100 ohms (nominal), which makes it ideal for DS1. The cable comes in configurations of 4 to 50 pairs and, as of this printing, has a UL-Type CMR listing on all pair sizes except for the four pair which has a UL-Type CM listing. There is also a plenum version of the cable available with product code 2249C and a UL-Type CMP Listing.

1161A-Type Cable

For cable runs to the DIXI-1 greater than 450 feet (137 m) and up to 565 feet (172 m), the 1161A cable family is recommended. The 1161A cable family is constructed with a 24 AWG (.51mm) twisted pair with a HDPE insulation and a single aluminum/polymer foil laminate shield with solid 24 AWG (.51 mm) drain wire and a PVC jacket. The 1161A cable has 20% reduction in cable diameter compared to the 600C series cable of like pair

counts and a 25% reduction in the cable diameter compared to the 600B cable of like pair counts. It is also lighter in weight and easier to handle than either the 600 series cable families. Its transmission characteristics include attenuation of 6.0 dB/100 feet (305 m) at 772 kHz and a characteristic impedance of 100 ohms (nominal). This product is UL Listed Type CMR and C(UL) CMG 75C for all pair sizes.

600C-Type Cable

The 600C-type cable is 22 AWG (0.64 mm) twisted pair with dual solid PE/PVC insulation. The 600C cable has a dual aluminum foil shield with solid 22 AWG drain wire and a PVC jacket. It is significantly more flexible, lighter in weight, and is easier to handle than the earlier 600B-type with corrugated aluminum shield. Because of the larger gauge, its transmission characteristics include attenuation of 4.1 dB/1,000 feet (305 m) at 772 kHz and characteristic impedance of 100 ohms (nominal). Available in 6- to

32-pair configurations, the 600C cable has a UL-Type CMR listing on pair sizes 25 to 32 and UL-Type CM listing on pair sizes 6 to 16. It is recommended for cable runs up to 655 feet (200 m). The maximum length of a cable between the digital equipment and the DSX is 655 feet (200 m). This is consistent with the range of settings available on the equipment Line Build Outs. For runs greater than 655 feet (200 m), Intra-Office Repeaters (IOR) are required.

Ordering Information

Selected cable codes are provided in the following tables. All Comcodes listed are for variable length packages (RVAR). This allows the desired length to be ordered rather than requiring a minimum order quantity. See the Electronic Wire and Cable Catalog, Select Code 3807B, for further information.

1249C Non-Plenum Series Cable (26 AWG)

Apparatus Code	Description	Diameter	Comcode
1249 004C RVAR	4 pair	0.27 inches (6.86 mm)	106 371 313
1249 006C RVAR	6 pair	0.28 inches (7.11 mm)	106 371 339
1249 012C RVAR	12 pair	0.35 inches (8.89 mm)	106 371 545
1249 016C RVAR	16 pair	0.38 inches (9.65 mm)	106 371 560
1249 020C RVAR	20 pair	0.42 inches (10.67 mm)	106 371 370
1249 025C RVAR	25 pair	0.45 inches (11.43 mm)	106 371 396
1249 028C RVAR	28 pair	0.45 inches (11.43 mm)	106 371 404
1249 032C RVAR	32 pair	0.47 inches (11.94 mm)	106 371 446
1249 050C RVAR	50 pair	0.61 inches (15.49 mm)	106 371 461

2249C Plenum Series Cable (26 AWG)

Apparatus Code	Description	Diameter	Comcode
2249 004C RVAR	4 pair	0.21 inches (5.33 mm)	106 078 462
2249 012C RVAR	12 pair	0.305 inches (7.75 mm)	106 078 280
2249 020C RVAR	20 pair	0.375 inches (9.53 mm)	106 078 348
2249 025C RVAR	25 pair	0.41 inches (10.41 mm)	106 078 363
2249 028C RVAR	28 pair	0.43 inches (10.92 mm)	106 078 389
2249 032C RVAR	32 pair	0.45 inches (11.43 mm)	106 078 405
2249 050C RVAR	50 pair	0.50 inches (12.70 mm)	106 078 439

1161A-Series Cable (24 AWG)

Apparatus Code	Description	Diameter	Comcode
1161 004A RVAR	4 pair	0.26 inches (6.6 mm)	108 236 605
1161 006A RVAR	6 pair	0.28 inches (7.1 mm)	108 236 613
1161 012A RVAR	12 pair	0.35 inches (8.9 mm)	108 236 621
1161 016A RVAR	16 pair	0.39 inches (9.9 mm)	108 236 647
1161 025A RVAR	25 pair	0.48 inches (12.2 mm)	108 236 662
1161 028A RVAR	28 pair	0.51 inches (13.0 mm)	108 324 609
1161 032A RVAR	32 pair	0.55 inches (14.0 mm)	108 341 744
1161 050A RVAR	50 pair	0.65 inches (16.5 mm)	108 236 696

600C-Series Cable (22AWG)

Apparatus Code	Description	Diameter	Comcode
606C-6/22 RVAR	6 pair	0.34 inches (8.64 mm)	106 556 491
607C-12/22 RVAR	12 pair	0.43 inches (10.92 mm)	106 556 541
608C-16/22 RVAR	16 pair	0.49 inches (12.45 mm)	106 556 514
609C-25/22 RVAR	25 pair	0.59 inches (14.99 mm)	106 556 608
616C-28/22 RVAR	28 pair	0.64 inches (16.26 mm)	106 556 624
613C-30/22 RVAR	30 pair	0.64 inches (16.26 mm)	106 556 640
615C-32/22 RVAR	32 pair	0.66 inches (16.76 mm)	106 556 723
618C-56/22 RVAR	56 pair	0.86 inches (21.8 mm)	107 732 398

