

1.35V DDR3 SDRAM RDIMM

MT9KSF12872PZ – 1GB

MT9KSF25672PZ – 2GB

Features

- DDR3 functionality and operations supported as defined in the component data sheet
- 240-pin, registered dual in-line memory module (RDIMM)
- Fast data transfer rates: PC3-12800, PC3-10600, PC3-8500, or PC3-6400
- 1GB (128 Meg x72), 2GB (256 Meg x 72)
- $V_{DD} = 1.35V$ (1.283V to 1.45V)
- Backward-compatible to $V_{DD} = +1.5V \pm 0.075V$
- $V_{DDSPD} = +3.0V$ to $+3.6V$
- Supports ECC error detection and correction
- Nominal and dynamic on-die termination (ODT) for data, strobe, and mask signals
- Single rank
- On-board I²C temperature sensor with integrated serial presence-detect (SPD) EEPROM
- Fixed burst chop (BC) of 4 and burst length (BL) of 8 via the mode register set (MRS)
- Selectable BC4 or BL8 on-the-fly (OTF)
- Gold edge contacts
- Halogen-free
- Fly-by topology
- Terminated control, command, and address bus

Figure 1: 240-Pin RDIMM (MO-269 R/C A)

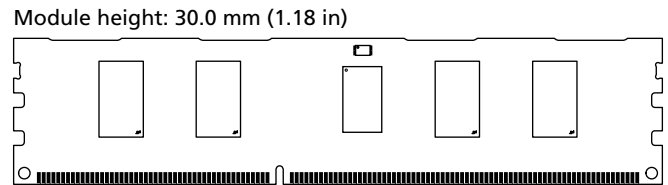

Options

- Operating temperature
 - Commercial ($0^{\circ}C \leq T_A \leq +70^{\circ}C$)
- Package
 - 240-pin DIMM (halogen-free)
- Frequency/CAS latency
 - 1.25ns @ CL = 11 (DDR3-1600)
 - 1.5ns @ CL = 9 (DDR3-1333)
 - 1.87ns @ CL = 7 (DDR3-1066)
 - 1.87ns @ CL = 8 (DDR3-1066)¹
 - 2.5ns @ CL = 5 (DDR3-800)¹
 - 2.5ns @ CL = 6 (DDR3-800)¹

Marking

None
Z
-1G6
-1G4
-1G1
-1G0
-80C
-80B

Note: 1. Not recommended for new designs.

Table 1: Key Timing Parameters

Speed Grade	Industry Nomenclature	Data Rate (MT/s)							t _{RCD} (ns)	t _{RP} (ns)	t _{RC} (ns)
		CL = 11	CL = 10	CL = 9	CL = 8	CL = 7	CL = 6	CL = 5			
-1G6	PC3-12800	1600	1333	1333	1066	1066	800	667	13.125	13.125	48.125
-1G4	PC3-10600	–	1333	1333	1066	1066	800	667	13.125	13.125	49.125
-1G1	PC3-8500	–	–	–	1066	1066	800	667	13.125	13.125	50.625
-1G0	PC3-8500	–	–	–	1066	–	800	667	15	15	52.5
-80C	PC3-6400	–	–	–	–	–	800	800	12.5	12.5	50
-80B	PC3-6400	–	–	–	–	–	800	667	15	15	52.5



Table 2: Addressing

Parameter	1GB	2GB
Refresh count	8K	8K
Row address	16K A[13:0]	32K A[14:0]
Device bank address	8 BA[2:0]	8 BA[2:0]
Device configuration	1Gb (128 Meg x 8)	2Gb (256 Meg x 8)
Column address	1K A[9:0]	1K A[9:0]
Module rank address	1 S#0	1 S#0

Table 3: Part Numbers and Timing Parameters – 1GB Modules

Base device: MT41K128M8JP,¹ 1Gb 1.35V DDR3 SDRAM

Part Number ²	Module Density	Configuration	Module Bandwidth	Memory Clock/ Data Rate	Clock Cycles (CL- ^t RCD- ^t RP)
MT9KSF12872PZ-1G6__	1GB	128 Meg x 72	12.8 GB/s	1.25ns/1600 MT/s	11-11-11
MT9KSF12872PZ-1G4__	1GB	128 Meg x 72	10.6 GB/s	1.5ns/1333 MT/s	9-9-9
MT9KSF12872PZ-1G1__	1GB	128 Meg x 72	8.5 GB/s	1.87ns/1066 MT/s	7-7-7

Table 4: Part Numbers and Timing Parameters – 2GB Modules

Base device: MT41K256M8HX,¹ 2Gb 1.35V DDR3 SDRAM

Part Number ²	Module Density	Configuration	Module Bandwidth	Memory Clock/ Data Rate	Clock Cycles (CL- ^t RCD- ^t RP)
MT9KSF25672PZ-1G6__	2GB	256 Meg x 72	12.8 GB/s	1.25ns/1600 MT/s	11-11-11
MT9KSF25672PZ-1G4__	2GB	256 Meg x 72	10.6 GB/s	1.5ns/1333 MT/s	9-9-9
MT9KSF25672PZ-1G1__	2GB	256 Meg x 72	8.5 GB/s	1.87ns/1066 MT/s	7-7-7

- Notes: 1. The data sheet for the base device can be found on Micron’s Web site.
2. All part numbers end with a two-place code (not shown) that designates component and PCB revisions. Consult factory for current revision codes. Example: MT9KSF12872PZ-1G4F1.



1GB, 2GB (x72, ECC, SR) 240-Pin 1.35V Halogen-Free DDR3 RDIMM Pin Assignments and Descriptions

Pin Assignments and Descriptions

Table 5: Pin Assignments

240-Pin DDR3 RDIMM Front								240-Pin DDR3 RDIMM Back							
Pin	Symbol	Pin	Symbol	Pin	Symbol	Pin	Symbol	Pin	Symbol	Pin	Symbol	Pin	Symbol	Pin	Symbol
1	V _{REFDQ}	31	DQ25	61	A2	91	DQ41	121	V _{SS}	151	V _{SS}	181	A1	211	V _{SS}
2	V _{SS}	32	V _{SS}	62	V _{DD}	92	V _{SS}	122	DQ4	152	DM3/ TDQS12	182	V _{DD}	212	DM5/ TDQS14
3	DQ0	33	DQS3#	63	NU	93	DQS5#	123	DQ5	153	NF/ TDQS12#	183	V _{DD}	213	NF/ TDQS14#
4	DQ1	34	DQS3	64	NU	94	DQS5	124	V _{SS}	154	V _{SS}	184	CK0	214	V _{SS}
5	V _{SS}	35	V _{SS}	65	V _{DD}	95	V _{SS}	125	DM0/ TDQS9	155	DQ30	185	CK0#	215	DQ46
6	DQS0#	36	DQ26	66	V _{DD}	96	DQ42	126	NF/ TDQS9#	156	DQ31	186	V _{DD}	216	DQ47
7	DQS0	37	DQ27	67	V _{REFCA}	97	DQ43	127	V _{SS}	157	V _{SS}	187	EVENT#	217	V _{SS}
8	V _{SS}	38	V _{SS}	68	Par_In	98	V _{SS}	128	DQ6	158	CB4	188	A0	218	DQ52
9	DQ2	39	CB0	69	V _{DD}	99	DQ48	129	DQ7	159	CB5	189	V _{DD}	219	DQ53
10	DQ3	40	CB1	70	A10	100	DQ49	130	V _{SS}	160	V _{SS}	190	BA1	220	V _{SS}
11	V _{SS}	41	V _{SS}	71	BA0	101	V _{SS}	131	DQ12	161	DM8/ TDQS17	191	V _{DD}	221	DM6/ TDQS15
12	DQ8	42	DQS8#	72	V _{DD}	102	DQS6#	132	DQ13	162	NF/ TDQS17#	192	RAS#	222	NF/ TDQS15#
13	DQ9	43	DQS8	73	WE#	103	DQS6	133	V _{SS}	163	V _{SS}	193	S0#	223	V _{SS}
14	V _{SS}	44	V _{SS}	74	CAS#	104	V _{SS}	134	DM1/ TDQS10	164	CB6	194	V _{DD}	224	DQ54
15	DQS1#	45	CB2	75	V _{DD}	105	DQ50	135	NF/ TDQS10#	165	CB7	195	ODT0	225	DQ55
16	DQS1	46	CB3	76	S1	106	DQ51	136	V _{SS}	166	V _{SS}	196	A13	226	V _{SS}
17	V _{SS}	47	V _{SS}	77	ODT1	107	V _{SS}	137	DQ14	167	NC	197	V _{DD}	227	DQ60
18	DQ10	48	V _{TT}	78	V _{DD}	108	DQ56	138	DQ15	168	RESET#	198	NC	228	DQ61
19	DQ11	49	V _{TT}	79	NC	109	DQ57	139	V _{SS}	169	NC	199	V _{SS}	229	V _{SS}
20	V _{SS}	50	CKE0	80	V _{SS}	110	V _{SS}	140	DQ20	170	V _{DD}	200	DQ36	230	DM7/ TDQS16
21	DQ16	51	V _{DD}	81	DQ32	111	DQS7#	141	DQ21	171	A15	201	DQ37	231	NF/ TDQS16#
22	DQ17	52	BA2	82	DQ33	112	DQS7	142	V _{SS}	172	A14	202	V _{SS}	232	V _{SS}
23	V _{SS}	53	Err_Out#	83	V _{SS}	113	V _{SS}	143	DM2/ TDQS11	173	V _{DD}	203	DM4/ TDQS13	233	DQ62
24	DQS2#	54	V _{DD}	84	DQS4#	114	DQ58	144	NF/ TDQS11#	174	A12	204	NF/ TDQS13#	234	DQ63
25	DQS2	55	A11	85	DQS4	115	DQ59	145	V _{SS}	175	A9	205	V _{SS}	235	V _{SS}
26	V _{SS}	56	A7	86	V _{SS}	116	V _{SS}	146	DQ22	176	V _{DD}	206	DQ38	236	V _{DDSPD}
27	DQ18	57	V _{DD}	87	DQ34	117	SA0	147	DQ23#	177	A8	207	DQ39	237	SA1
28	DQ19	58	A5	88	DQ35	118	SCL	148	V _{SS}	178	A6	208	V _{SS}	238	SDA
29	V _{SS}	59	A4	89	V _{SS}	119	SA2	149	DQ28	179	V _{DD}	209	DQ44	239	V _{SS}
30	DQ24	60	V _{DD}	90	DQ40	120	V _{TT}	150	DQ29	180	A3	210	DQ45	240	V _{TT}



1GB, 2GB (x72, ECC, SR) 240-Pin 1.35V Halogen-Free DDR3 RDIMM Pin Assignments and Descriptions

Table 6: Pin Descriptions

Symbol	Type	Description
A[15:0]	Input	Address inputs: Provide the row address for ACTIVATE commands, and the column address and auto precharge bit (A10) for READ/WRITE commands, to select one location out of the memory array in the respective bank. A10 is sampled during a PRECHARGE command to determine whether the PRECHARGE applies to one bank (A10 LOW, bank selected by BA[2:0]) or all banks (A10 HIGH). If only one bank is to be precharged, the bank is selected by BA. A12 is also used for BC4/BL8 identification as “BL on-the-fly” during CAS commands. The address inputs also provide the op-code during the mode register command set. A[13:0] address the 1Gb 1.35V DDR3 devices. A[14:0] address the 2Gb 1.35V DDR3 devices. A15 is needed to calculate parity on the command/address bus.
BA[2:0]	Input	Bank address inputs: BA[2:0] define the device bank to which an ACTIVATE, READ, WRITE, or PRECHARGE command is being applied. BA[2:0] define which mode register (MR0, MR1, MR2, and MR3) is loaded during the LOAD MODE command. BA[1:0] are used as part of the parity calculation.
CK0, CK0#	Input	Clock: CK and CK# are differential clock inputs. All control, command, and address input signals are sampled on the crossing of the positive edge of CK and the negative edge of CK#.
CKE0	Input	Clock enable: CKE enables (registered HIGH) and disables (registered LOW) internal circuitry and clocks on the DRAM.
DM[8:0] (TDQS[17:9] TDQS#[17:9])	Input	Input data mask: DM is an input mask signal for write data. Input data is masked when DM is sampled HIGH, along with the input data, during a write access. DM is sampled on both edges of the DQS. Although the DM pins are input-only, the DM loading is designed to match that of the DQ and DQS pins. When TDQS is enabled, DM is disabled and TDQS and TDQS# provide termination resistance; otherwise, the TDQS# pins are no function.
ODT0	Input	On-die termination: ODT enables (registered HIGH) and disables (registered LOW) termination resistance internal to the DRAM. When enabled in normal operation, ODT is only applied to the following pins: DQ, DQS, DQS#, and DM. The ODT input will be ignored if disabled via the LOAD MODE command.
Par_In	Input	Parity input: Parity bit for the address, RAS#, CAS#, and WE#.
RAS#, CAS#, WE#	Input	Command inputs: RAS#, CAS#, and WE# (along with S#) define the command being entered.
RESET#	Input (LVCMOS)	Reset: RESET# is an active LOW CMOS input referenced to V _{SS} . The RESET# input receiver is a CMOS input defined as a rail-to-rail signal with DC HIGH $\geq 0.8 \times V_{DD}$ and DC LOW $\leq 0.2 \times V_{DD}$. RESET# assertion and deassertion are asynchronous.
S0#	Input	Chip select: S# enables (registered LOW) and disables (registered HIGH) the command decoder.
SA[2:0]	Input	Serial address inputs: These pins are used to configure the temperature sensor/SPD EEPROM address range on the I ² C bus.
SCL	Input	Serial clock for temperature sensor/SPD EEPROM: SCL is used to synchronize communication to and from the temperature sensor/SPD EEPROM.
CB[7:0]	I/O	Check bits: Data used for ECC.
DQ[63:0]	I/O	Data input/output: Bidirectional data bus.
DQS[8:0] DQS#[8:0]	I/O	Data strobe: DQS and DQS# are differential data strobes. Output with read data. Edge-aligned with read data. Input with write data. Center-aligned with write data.



1GB, 2GB (x72, ECC, SR) 240-Pin 1.35V Halogen-Free DDR3 RDIMM Pin Assignments and Descriptions

Table 6: Pin Descriptions (Continued)

Symbol	Type	Description
SDA	I/O	Serial data: SDA is a bidirectional pin used to transfer addresses and data into and out of the temperature sensor/SPD EEPROM on the module on the I ² C bus.
Err_Out#	Output (open drain)	Parity error output: Parity error found on the command and address bus.
EVENT#	Output (open drain)	Temperature event: The EVENT# pin is asserted by the temperature sensor when critical temperature thresholds have been exceeded.
V _{DD}	Supply	Power supply: 1.35V (1.283V to 1.45V). The component V _{DD} and V _{DDQ} are connected to the module V _{DD} .
V _{DDSPD}	Supply	Temperature sensor/SPD EEPROM power supply: +3.0V to +3.6V.
V _{REFCA}	Supply	Reference voltage: Control, command, and address (V _{DD/2}).
V _{REFDQ}	Supply	Reference voltage: DQ, DM (V _{DD/2}).
V _{SS}	Supply	Ground.
V _{TT}	Supply	Termination voltage: Used for control, command, and address (V _{DD/2}).
NC	–	No connect: These pins are not connected on the module.
NF	–	No function: Connected within the module, but provides no functionality.
NU	–	Not usable: No external connections allowed.



DQ Map

Table 7: Component-to-Module DQ Map

Component Reference Number	Component DQ	Module DQ	Module Pin Number	Component Reference Number	Component DQ	Module DQ	Module Pin Number
U1	0	10	18	U2	0	26	36
	1	13	132		1	29	150
	2	15	138		2	27	37
	3	9	13		3	25	31
	4	14	137		4	30	155
	5	12	131		5	28	149
	6	11	19		6	31	156
	7	8	12		7	24	30
U5	0	34	87	U6	0	50	105
	1	37	201		1	53	219
	2	39	207		2	55	225
	3	33	82		3	49	100
	4	38	206		4	54	224
	5	36	200		5	52	218
	6	35	88		6	51	106
	7	32	81		7	48	99
U7	0	57	109	U8	0	45	210
	1	62	233		1	42	96
	2	56	108		2	40	90
	3	59	115		3	47	216
	4	61	228		4	41	91
	5	63	234		5	43	97
	6	60	227		6	44	209
	7	58	114		7	46	215
U10	0	CB1	39	U11	0	21	141
	1	CB7	165		1	18	27
	2	CB0	39		2	17	22
	3	CB2	45		3	19	28
	4	CB5	159		4	20	140
	5	CB3	46		5	23	147
	6	CB4	158		6	16	21
	7	CB6	164		7	22	146

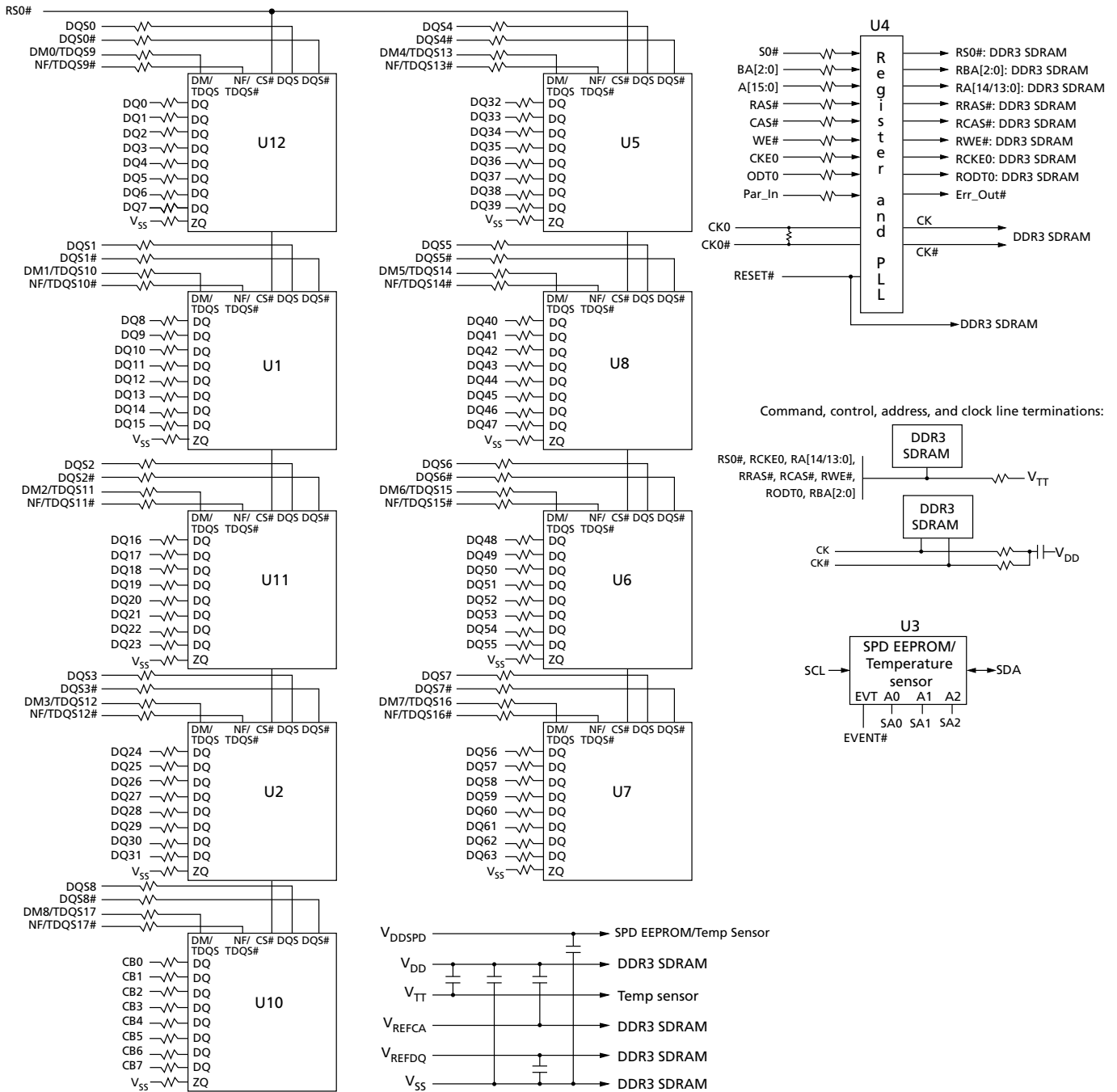

Table 7: Component-to-Module DQ Map (Continued)

Component Reference Number	Component DQ	Module DQ	Module Pin Number	Component Reference Number	Component DQ	Module DQ	Module Pin Number
U12	0	5	123				
	1	2	9				
	2	1	4				
	3	6	128				
	4	4	122				
	5	3	10				
	6	0	3				
	7	7	129				

Functional Block Diagram

Figure 2: Functional Block Diagram



Note: 1. The ZQ ball on each DDR3 component is connected to an external 240Ω ±1% resistor that is tied to ground. It is used for the calibration of the component's ODT and output driver.

General Description

DDR3 SDRAM modules are high-speed, CMOS dynamic random access memory modules that use internally configured 8-bank DDR3 SDRAM devices. DDR3 SDRAM modules use DDR architecture to achieve high-speed operation. DDR3 architecture is essentially an $8n$ -prefetch architecture with an interface designed to transfer two data words per clock cycle at the I/O pins. A single read or write access for the DDR3 SDRAM module effectively consists of a single $8n$ -bit-wide, one-clock-cycle data transfer at the internal DRAM core and eight corresponding n -bit-wide, one-half-clock-cycle data transfers at the I/O pins.

DDR3 modules use two sets of differential signals: DQS, DQS# to capture data and CK and CK# to capture commands, addresses, and control signals. Differential clocks and data strobes ensure exceptional noise immunity for these signals and provide precise crossing points to capture input signals.

Fly-By Topology

DDR3 modules use faster clock speeds than earlier DDR technologies, making signal quality more important than ever. For improved signal quality, the clock, control, command, and address buses have been routed in a fly-by topology, where each clock, control, command, and address pin on each DRAM is connected to a single trace and terminated (rather than a tree structure, where the termination is off the module near the connector). Inherent to fly-by topology, the timing skew between the clock and DQS signals can be easily accounted for by using the write-leveling feature of DDR3.

Registering Clock Driver Operation

Registered DDR3 SDRAM modules use a registering clock driver device consisting of a register and a phase-lock loop (PLL). The device complies with the JEDEC standard "Definition of the SSTE32882 Registering Clock Driver with Parity and Quad Chip Selects for DDR3 RDIMM Applications."

The register section of the registering clock driver latches command and address input signals on the rising clock edge. The PLL section of the registering clock driver receives and redrives the differential clock signals (CK, CK#) to the DDR3 SDRAM devices. The register(s) and PLL reduce clock, control, command, and address signals loading by isolating DRAM from the system controller.

Parity Operations

The registering clock driver can accept a parity bit from the system's memory controller, providing even parity for the control, command, and address bus. Parity errors are flagged on the Err_Out# pin. Systems not using parity are expected to function without issue if Par_In and Err_Out# are left as no connects to the system.



Temperature Sensor with Serial Presence-Detect EEPROM

Thermal Sensor Operations

The temperature from the integrated thermal sensor is monitored and converts into a digital word via the I²C bus. System designers can use the user-programmable registers to create a custom temperature-sensing solution based on system requirements. Programming and configuration details comply with JEDEC standard No. 21-C page 4.7-1 "Definition of the TSE2002av, Serial Presence Detect with Temperature Sensor."

Serial Presence-Detect EEPROM Operation

DDR3 SDRAM modules incorporate serial presence-detect. The SPD data is stored in a 256-byte EEPROM. The first 128 bytes are programmed by Micron to comply with JEDEC standard JC-45 "Appendix X: Serial Presence Detect (SPD) for DDR3 SDRAM Modules." These bytes identify module-specific timing parameters, configuration information, and physical attributes. User-specific information can be written into the remaining 128 bytes of storage. READ/WRITE operations between the system (master) and the EEPROM (slave) device occur via an I²C bus. Write protect (WP) is connected to V_{SS}, permanently disabling hardware write protect. For further information please refer to Micron technical note TN-04-42, "Memory Module Serial Presence-Detect."



Electrical Specifications

Stresses greater than those listed may cause permanent damage to the module. This is a stress rating only, and functional operation of the module at these or any other conditions outside those indicated in each device's data sheet is not implied. Exposure to absolute maximum rating conditions for extended periods may adversely affect reliability.

Table 8: Absolute Maximum Ratings

Symbol	Parameter	Min	Max	Units
V_{DD}	V_{DD} supply voltage relative to V_{SS}	-0.4	+1.975	V
V_{IN}, V_{OUT}	Voltage on any pin relative to V_{SS}	-0.4	+1.975	V

Table 9: Operating Conditions

Symbol	Parameter	Min	Nom	Max	Units	Notes	
V_{DD}	V_{DD} supply voltage	1.283	1.35	1.45	V		
$V_{REFCA(DC)}$	Input reference voltage command/address bus	$0.49 \times V_{DD}$	$0.5 \times V_{DD}$	$0.51 \times V_{DD}$	V		
$V_{REFDQ(DC)}$	I/O reference voltage DQ bus	$0.49 \times V_{DD}$	$0.5 \times V_{DD}$	$0.51 \times V_{DD}$	V		
I_{VTT}	Termination reference current from V_{TT}	-600	-	+600	mA		
V_{TT}	Termination reference voltage (DC) – command/address bus	$0.49 \times V_{DD} - 20mV$	$0.5 \times V_{DD}$	$0.51 \times V_{DD} + 20mV$	V	1	
I_I	Input leakage current; Any input $0V \leq V_{IN} \leq V_{DD}$; V_{REF} input $0V \leq V_{IN} \leq 0.95V$ (All other pins not under test = $0V$)	Address inputs, RAS#, CAS#, WE#, S#, CKE, ODT, BA, CK, CK#	TBD	TBD	TBD	μA	
I_{OZ}	Output leakage current; $0V \leq V_{OUT} \leq V_{DD}$; DQ and ODT are disabled; ODT is HIGH	DQ, DQS, DQS#	-5	0	+5	μA	
I_{VREF}	V_{REF} supply leakage current; $V_{REFDQ} = V_{DD}/2$ or $V_{REFCA} = V_{DD}/2$ (All other pins not under test = $0V$)		-9	0	+9	μA	
T_A	Module ambient operating temperature	Commercial	0	-	+70	$^{\circ}C$	2, 3
T_C	DDR3 SDRAM component case operating temperature	Commercial	0	-	+95	$^{\circ}C$	2, 3, 4

- Notes:
- V_{TT} termination voltage in excess of the stated limit will adversely affect the command and address signals' voltage margin and will reduce timing margins.
 - T_A and T_C are simultaneous requirements.
 - For further information, refer to technical note TN-00-08: "Thermal Applications," available on Micron's Web site.
 - The refresh rate is required to double when $85^{\circ}C < T_C \leq 95^{\circ}C$.



DRAM Operating Conditions

Recommended AC operating conditions are given in the DDR3 component data sheets. Component specifications are available on Micron's Web site. Module speed grades correlate with component speed grades, as shown below.

Table 10: Module and Component Speed Grades

DDR3 components may exceed the listed module speed grades; module may not be available in all listed speed grades

Module Speed Grade	Component Speed Grade
-1G6	-125
-1G4	-15E
-1G1	-187E
-1G0	-187
-80C	-25E
-80B	-25

Design Considerations

Simulations

Micron memory modules are designed to optimize signal integrity through carefully designed terminations, controlled board impedances, routing topologies, trace length matching, and decoupling. However, good signal integrity starts at the system level. Micron encourages designers to simulate the signal characteristics of the system's memory bus to ensure adequate signal integrity of the entire memory system.

Power

Operating voltages are specified at the DRAM, not at the edge connector of the module. Designers must account for any system voltage drops at anticipated power levels to ensure the required supply voltage is maintained.



I_{DD} Specifications

Table 11: DDR3 I_{DD} Specifications and Conditions – 1GB

Values are for the MT41K128M8 DDR3 SDRAM only and are computed from values specified in the 1Gb (128 Meg x 8) 1.35V component data sheet

Parameter	Symbol	1600	1333	1066	Units
Operating current 0: One bank ACTIVATE-to-PRE-CHARGE	I _{DD0}	TBD	855	765	mA
Operating current 1: One bank ACTIVATE-to-READ-to-PRECHARGE	I _{DD1}	TBD	990	900	mA
Precharge power-down current: Slow exit	I _{DD2P}	TBD	90	72	mA
Precharge power-down current: Fast exit	I _{DD2P}	TBD	270	225	mA
Precharge quiet standby current	I _{DD2Q}	TBD	495	405	mA
Precharge standby current	I _{DD2N}	TBD	495	405	mA
Precharge standby ODT current	I _{DD2NT}	TBD	675	585	mA
Active power-down current	I _{DD3P}	TBD	333	270	mA
Active standby current	I _{DD3N}	TBD	540	450	mA
Burst read operating current	I _{DD4R}	TBD	1305	1080	mA
Burst write operating current	I _{DD4W}	TBD	1305	1080	mA
Refresh current	I _{DD5B}	TBD	1665	1575	mA
Self refresh temperature current: MAX T _C = 85°C	I _{DD6}	TBD	54	54	mA
Self refresh temperature current (SRT-enabled): MAX T _C = 95°C	I _{DD6ET}	TBD	81	81	mA
All banks interleaved read current	I _{DD7}	TBD	3240	2610	mA
Reset current	I _{DD8}	TBD	108	90	mA



**1GB, 2GB (x72, ECC, SR) 240-Pin 1.35V Halogen-Free DDR3
RDIMM
Electrical Specifications**

Table 12: DDR3 I_{DD} Specifications and Conditions – 2GB

Values are for the MT41K256M8 DDR3 SDRAM only and are computed from values specified in the 2Gb (256 Meg x 8) 1.35V component data sheet

Parameter	Symbol	1600	1333	1066	Units
Operating current 0: One bank ACTIVATE-to-PRE-CHARGE	I _{DD0}	TBD	TBD	TBD	mA
Operating current 1: One bank ACTIVATE-to-READ-to-PRECHARGE	I _{DD1}	TBD	TBD	TBD	mA
Precharge power-down current: Slow exit	I _{DD2P}	TBD	TBD	TBD	mA
Precharge power-down current: Fast exit	I _{DD2P}	TBD	TBD	TBD	mA
Precharge quiet standby current	I _{DD2Q}	TBD	TBD	TBD	mA
Precharge standby current	I _{DD2N}	TBD	TBD	TBD	mA
Precharge standby ODT current	I _{DD2NT}	TBD	TBD	TBD	mA
Active power-down current	I _{DD3P}	TBD	TBD	TBD	mA
Active standby current	I _{DD3N}	TBD	TBD	TBD	mA
Burst read operating current	I _{DD4R}	TBD	TBD	TBD	mA
Burst write operating current	I _{DD4W}	TBD	TBD	TBD	mA
Refresh current	I _{DD5B}	TBD	TBD	TBD	mA
Self refresh temperature current: MAX T _C = 85°C	I _{DD6}	TBD	TBD	TBD	mA
Self refresh temperature current (SRT-enabled): MAX T _C = 95°C	I _{DD6ET}	TBD	TBD	TBD	mA
All banks interleaved read current	I _{DD7}	TBD	TBD	TBD	mA
Reset current	I _{DD8}	TBD	TBD	TBD	mA



Registering Clock Driver Specifications

Table 13: Registering Clock Driver Electrical Characteristics

SSTE32882 devices or equivalent

Symbol	Parameter	Pins	Min	Nom	Max	Units
V_{DD}	DC supply voltage	–	1.425	1.5	1.575	V
V_{REF}	DC reference voltage	–	$0.49 \times V_{DD} - 20\text{mV}$	$0.5 \times V_{DD}$	$0.51 \times V_{DD} + 20\text{mV}$	V
V_{TT}	DC termination voltage	–	$0.49 \times V_{DD} - 20\text{mV}$	$0.5 \times V_{DD}$	$0.51 \times V_{DD} + 20\text{mV}$	V
$V_{IH(AC)}$	AC high-level input voltage	Control, command, address	$V_{REF} + 175\text{mV}$	–	$V_{DD} + 400\text{mV}$	V
$V_{IL(AC)}$	AC low-level input voltage	Control, command, address	–0.4	–	$V_{REF} - 175\text{mV}$	V
$V_{IH(DC)}$	DC high-level input voltage	Control, command, address	$V_{REF} + 100\text{mV}$	–	$V_{DD} + 0.4$	V
$V_{IL(DC)}$	DC low-level input voltage	Control, command, address	–0.4	–	$V_{REF} - 100\text{mV}$	V
$V_{IH(CMOS)}$	High-level input voltage	RESET#, MIRROR	$0.65 \times V_{DD}$	–	V_{DD}	V
$V_{IL(CMOS)}$	Low-level input voltage	RESET#, MIRROR	0	–	$0.35 \times V_{DD}$	V
$V_{IX(AC)}$	Differential input cross point voltage range	CK, CK#, FBIN, FBIN#	$0.5 \times V_{DD} - 175\text{mV}$	$0.5 \times V_{DD}$	$0.5 \times V_{DD} + 175\text{mV}$	V
$V_{ID(AC)}$	Differential input voltage	CK, CK#	350	–	$V_{DD} + \text{TBD}$	mV
I_{OH}	High-level output current	Err_Out#	–	–	TBD	mA
I_{OL}	Low-level output current	Err_Out#	TBD	–	TBD	mA

Note: 1. Timing and switching specifications for the register listed are critical for proper operation of the DDR3 SDRAM RDIMMs. These are meant to be a subset of the parameters for the specific device used on the module.



Temperature Sensor with Serial Presence-Detect EEPROM

The temperature sensor continuously monitors the module's temperature and can be read back at any time over the I²C bus shared with the SPD EEPROM.

Table 14: Temperature Sensor with Serial Presence-Detect EEPROM Operating Conditions

Parameter/Condition	Symbol	Min	Max	Units
Supply voltage	V _{DDSPD}	+3.0	+3.6	V
Supply current: V _{DD} = 3.3V	I _{DD}	–	+2.0	mA
Input high voltage: Logic 1; SCL, SDA	V _{IH}	+1.45	V _{DDSPD} + 1	V
Input low voltage: Logic 0; SCL, SDA	V _{IL}	–	+0.55	V
Output low voltage: I _{OUT} = 2.1mA	V _{OL}	–	+0.4	V
Input current	I _{IN}	–5.0	+5.0	μA
Temperature sensing range	–	–40	+125	°C
Temperature sensor accuracy (class B)	–	–1.0	+1.0	°C

Table 15: Sensor and EEPROM Serial Interface Timing

Parameter/Condition	Symbol	Min	Max	Units
Time bus must be free before a new transition can start	t _{BUF}	4.7	–	μs
SDA fall time	t _F	20	300	ns
SDA rise time	t _R	–	1,000	ns
Data hold time	t _{HD:DAT}	200	900	ns
Start condition hold time	t _{H:STA}	4.0	–	μs
Clock HIGH period	t _{HIGH}	4.0	50	μs
Clock LOW period	t _{LOW}	4.7	–	μs
SCL clock frequency	t _{SCL}	10	100	kHz
Data setup time	t _{SU:DAT}	250	–	ns
Start condition setup time	t _{SU:STA}	4.7	–	μs
Stop condition setup time	t _{SU:STO}	4.0	–	μs

EVENT# Pin

The temperature sensor also adds the EVENT# pin (open drain). Not used by the SPD EEPROM, EVENT# is a temperature sensor output used to flag critical events that can be set up in the sensor's configuration register.

EVENT# has three defined modes of operation: interrupt mode, compare mode, and critical temperature mode. The open-drain output of EVENT# under the three separate operating modes is illustrated below. Event thresholds are programmed in the 0x01 register using a hysteresis. The alarm window provides a comparison window, with upper and lower limits set in the alarm upper boundary register and the alarm lower boundary register, respectively. When the alarm window is enabled, EVENT# will trigger whenever the temperature is outside the MIN or MAX values set by the user.



1GB, 2GB (x72, ECC, SR) 240-Pin 1.35V Halogen-Free DDR3 RDIMM Temperature Sensor with Serial Presence-Detect EEPROM

The interrupt mode enables software to reset EVENT# after a critical temperature threshold has been detected. Threshold points are set in the configuration register by the user. This mode triggers the critical temperature limit and both the MIN and MAX of the temperature window.

The compare mode is similar to the interrupt mode, except EVENT# cannot be reset by the user and only returns to the logic HIGH state when the temperature falls below the programmed thresholds.

Critical temperature mode triggers EVENT# only when the temperature has exceeded the programmed critical trip point. When the critical trip point has been reached, the temperature sensor goes into comparator mode, and the critical EVENT# cannot be cleared through software.

SM Bus Slave Subaddress Decoding

The temperature sensor's physical address differs from the SPD EEPROM's physical address: binary 0011 for A0, A1, A2, and RW#, where A2, A1, and A0 are the three slave subaddress pins and the RW# bit is the READ/WRITE flag.

If the slave base address is fixed for the temperature sensor/SPD EEPROM, then the pins set the subaddress bits of the slave address, enabling the devices to be located anywhere within the eight slave address locations. For example, they could be set from 30h to 3Eh.

Figure 3: EVENT# Pin Functionality

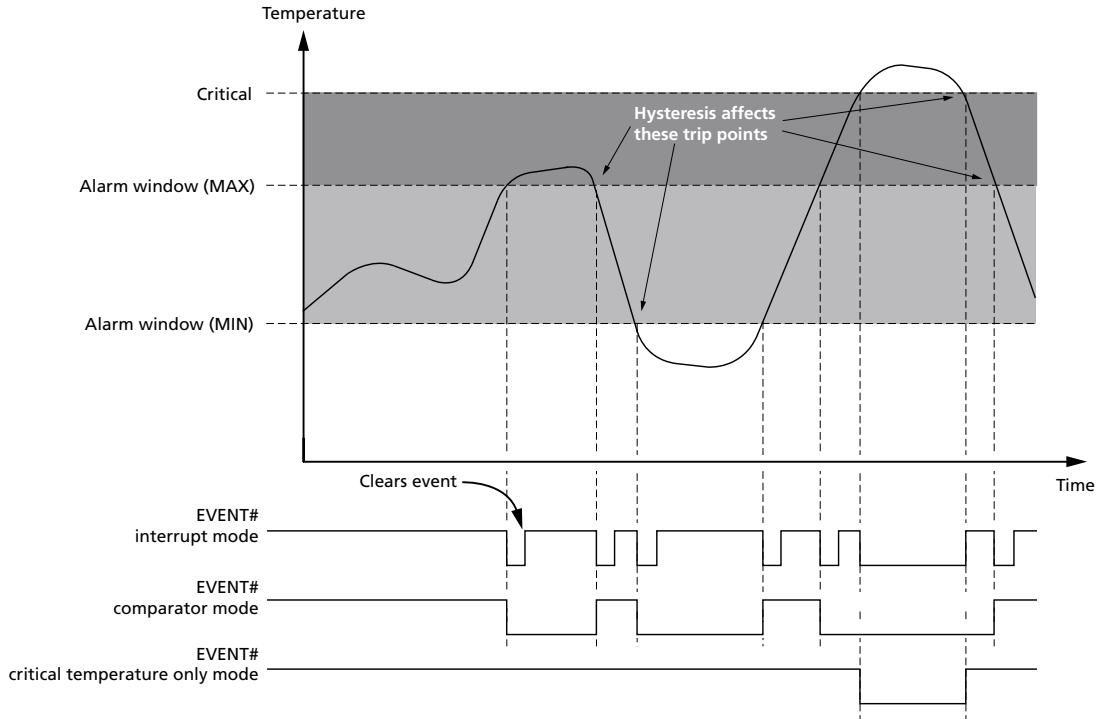

Table 16: Temperature Sensor Registers

Name	Address	Power-on Default
Pointer register	Not applicable	Undefined
Capability register	0x00	0x0001
Configuration register	0x01	0x0000
Alarm temperature upper boundary register	0x02	0x0000
Alarm temperature lower boundary register	0x03	0x0000
Critical temperature register	0x04	0x0000
Temperature register	0x05	Undefined

Pointer Register

The pointer register selects which of the 16-bit registers is being accessed in subsequent READ and WRITE operations. This register is a write-only register.



Table 17: Pointer Register Bits 0–7

Bit							
7	6	5	4	3	2	1	0
0	0	0	0	Register select	Register select	Register select	Register select

Table 18: Pointer Register Bits 0–2 Descriptions

Bit			Register
2	1	0	
0	0	0	Capability register
0	0	1	Configuration register
0	1	0	Alarm temperature upper boundary register
0	1	1	Alarm temperature lower boundary register
1	0	0	Critical temperature register
1	0	1	Temperature register

Capability Register

The capability register indicates the features and functionality supported by the temperature sensor. This register is a read-only register.

Table 19: Capability Register (Address: 0x00)

Bit							
15	14	13	12	11	10	9	8
RFU	RFU	RFU	RFU	RFU	RFU	RFU	RFU
Bit							
7	6	5	4	3	2	1	0
RFU	RFU	RFU	Temperature resolution		Wider range	Precision	Has alarm and critical temperature

Table 20: Capability Register Bit Description

Bit	Description
0	Basic capability 1: Has alarm and critical trip point capabilities
1	Accuracy 0: $\pm 2^{\circ}\text{C}$ over the active range and $\pm 3^{\circ}\text{C}$ over the monitor range 1: $\pm 1^{\circ}\text{C}$ over the active range and $\pm 2^{\circ}\text{C}$ over the monitor range
2	Wider range 0: Temperatures lower than 0°C are clamped to a binary value of 0 1: Temperatures below 0°C can be read



Table 20: Capability Register Bit Description (Continued)

Bit	Description
4:3	Temperature resolution 00: 0.5°C LSB 01: 0.25°C LSB 10: 0.125°C LSB 11: 0.0625°C LSB
15:5	0: Must be set to zero

Configuration Register

Table 21: Configuration Register (Address: 0x01)

Bit							
15	14	13	12	11	10	9	8
RFU	RFU	RFU	RFU	RFU	Hysteresis		Shutdown mode
Bit							
7	6	5	4	3	2	1	0
Critical lock bit	Alarm lock bit	Clear event	Event output status	Event output control	Critical event only	Event polarity	Event mode

Table 22: Configuration Register Bit Descriptions

Bit	Description	Notes
0	Event mode 0: Comparator mode 1: Interrupt mode	Event mode cannot be changed if either of the lock bits is set.
1	EVENT# polarity 0: Active LOW 1: Active HIGH	EVENT# polarity cannot be changed if either of the lock bits is set.
2	Critical event only 0: EVENT# trips on alarm or critical temperature event 1: EVENT# trips only if critical temperature is reached	
3	Event output control 0: Event output disabled 1: Event output enabled	
4	Event status 0: EVENT# has not been asserted by this device 1: EVENT# is being asserted due to an alarm window or critical temperature condition	This is a read-only field in the register. The event causing the event can be determined from the read temperature register.
5	Clear event 0: No effect 1: Clears the event when the temperature sensor is in the interrupt mode	



Table 22: Configuration Register Bit Descriptions (Continued)

Bit	Description	Notes
6	Alarm window lock bit 0: Alarm trips are not locked and can be changed 1: Alarm trips are locked and cannot be changed	
7	Critical trip lock bit 0: Critical trip is not locked and can be changed 1: Critical trip is locked and cannot be changed	
8	Shutdown mode 0: Enabled 1: Shutdown	The shutdown mode is a power-saving mode that disables the temperature sensor.
10:9	Hysteresis enable 00: Disable 01: Enable at 1.5°C 10: Enable at 3°C 11: Enable at 6°C	When enabled, a hysteresis is applied to temperature movement around the trip points (see Figure 4 (page 22)). As an example, if the hysteresis register is enabled to a delta of 6°C, the preset trip points will toggle when the temperature reaches the programmed value. These values will reset when the temperature drops below the trip points minus the set hysteresis level. In this case, this would be critical temperature minus 6°C. The hysteresis is applied to both the above alarm window and the below alarm window bits found in the read-only temperature register (see Table 23 (page 22)). EVENT# is also affected by this register.

Figure 4: Hysteresis Applied to Temperature Around Trip Points

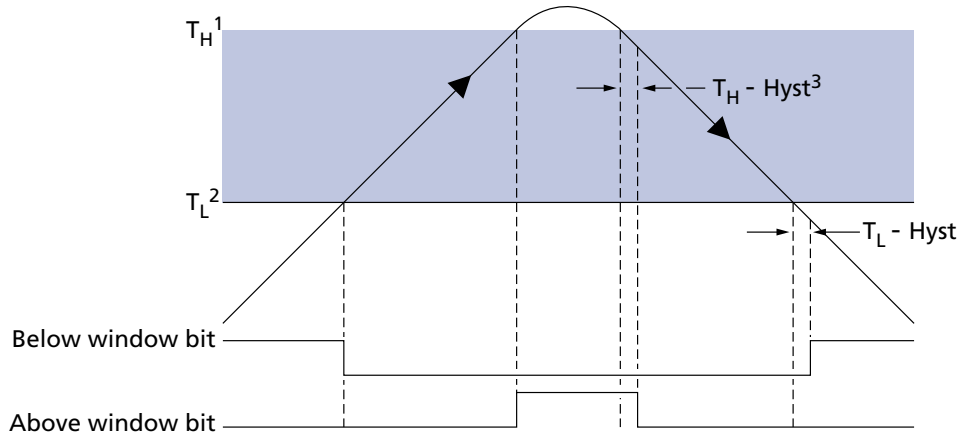

- Notes:
1. T_H is the value set in the alarm temperature upper boundary trip register.
 2. T_L is the value set in the alarm temperature lower boundary trip register.
 3. Hyst is the value set in the hysteresis bits of the configuration register.

Table 23: Hysteresis Applied to Alarm Window Bits in the Temperature Register

Condition	Below Alarm Window Bit		Above Alarm Window Bit	
	Temperature Gradient	Critical Temperature	Temperature Gradient	Critical Temperature
Sets	Falling	$T_L - \text{Hyst}$	Rising	T_H
Clears	Rising	T_L	Falling	$T_H - \text{Hyst}$

Temperature Format

The temperature trip point registers and temperature readout register use a 2's complement format to enable negative numbers. The least significant bit (LSB) is equal to 0.0625°C or 0.25°C, depending on which register is referenced. For example, assuming an LSB of 0.0625°C:

- A value of 0x018C would equal 24.75°C
- A value of 0x06C0 would equal 108°C
- A value of 0x1E74 would equal -24.75°C



Temperature Trip Point Registers

The upper and lower temperature boundary registers are used to set the maximum and minimum values of the alarm window. LSB for these registers is 0.25°C. All RFU bits in the register will always report zero.

Table 24: Alarm Temperature Lower Boundary Register (Address: 0x02)

Bit															
15	14	13	12	11	10	9	8	7	6	5	4	3	2	1	0
0	0	0	MSB										LSB	RFU	RFU
Alarm window upper boundary temperature															

Table 25: Alarm Temperature Lower Boundary Register (Address: 0x03)

Bit															
15	14	13	12	11	10	9	8	7	6	5	4	3	2	1	0
0	0	0	MSB										LSB	RFU	RFU
Alarm window lower boundary temperature															

Critical Temperature Register

The critical temperature register is used to set the maximum temperature above the alarm window. The LSB for this register is 0.25°C. All RFU bits in the register will always report zero.

Table 26: Critical Temperature Register (Address: 0x04)

Bit															
15	14	13	12	11	10	9	8	7	6	5	4	3	2	1	0
0	0	0	MSB										LSB	RFU	RFU
Critical temperature trip point															

Temperature Register

The temperature register is a read-only register that provides the current temperature detected by the temperature sensor. The LSB for this register is 0.0625°C with a resolution of 0.0625°C. The most significant bit (MSB) is 128°C in the readout section of this register.

The upper three bits of the register are used to monitor the trip points that are set in the previous three registers.



Table 27: Temperature Register (Address: 0x05)

Bit															
15	14	13	12	11	10	9	8	7	6	5	4	3	2	1	0
Above critical trip	Above alarm window	Below alarm window	MSB	Temperature											LSB

Table 28: Temperature Register Bit Descriptions

Bit	Description
13	Below alarm window 0: Temperature is equal to or above the lower boundary 1: Temperature is below alarm window
14	Above alarm window 0: Temperature is equal to or below the upper boundary 1: Temperature is above alarm window
15	Above critical trip point 0: Temperature is below critical trip point 1: Temperature is above critical trip point

Serial Presence-Detect Data

For the latest serial presence-detect data, refer to Micron's SPD page: www.micron.com/SPD.

Module Dimensions

Figure 5: 240-Pin DDR3 RDIMM

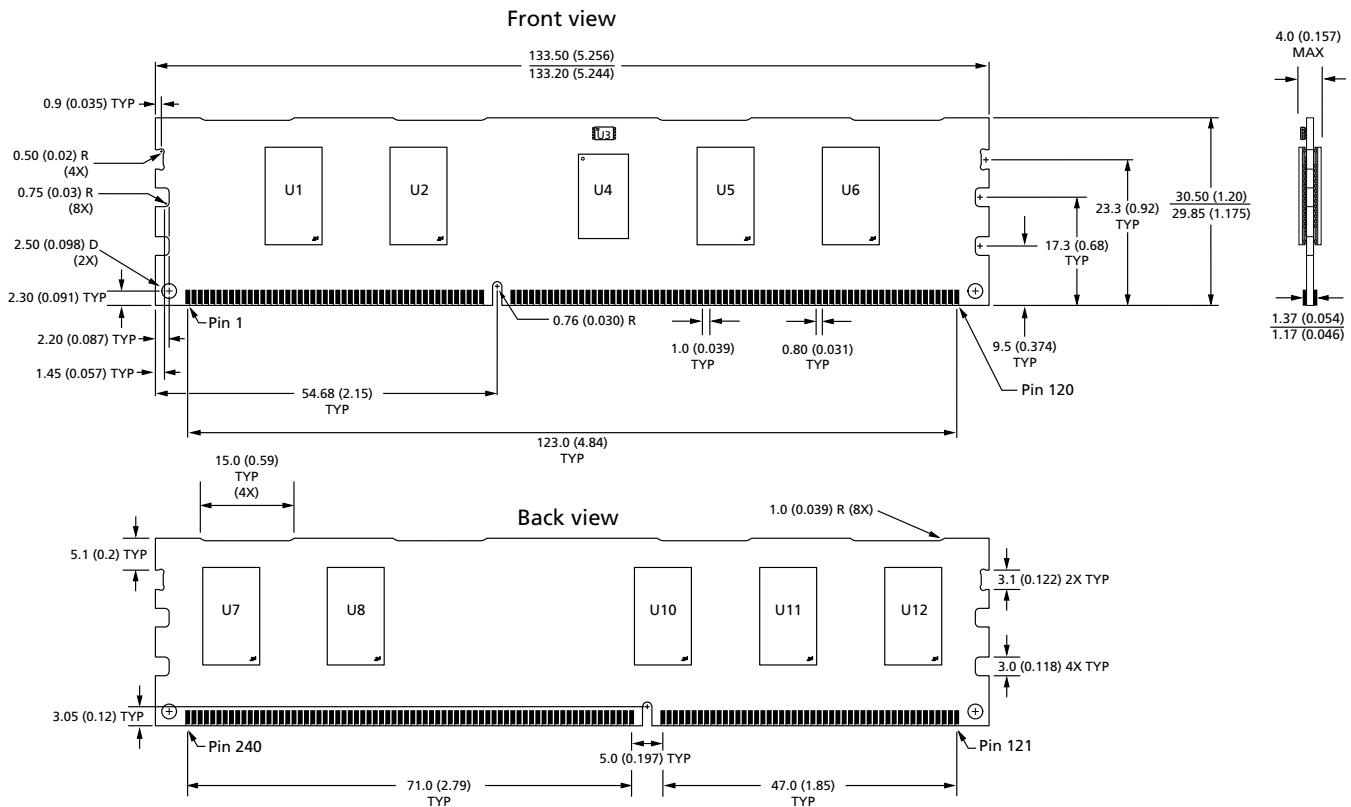

- Notes: 1. All dimensions are in millimeters (inches); MAX/MIN or typical (TYP) where noted.
2. The dimensional diagram is for reference only.

8000 S. Federal Way, P.O. Box 6, Boise, ID 83707-0006, Tel: 208-368-3900
www.micron.com/productsupport Customer Comment Line: 800-932-4992
 Micron and the Micron logo are trademarks of Micron Technology, Inc.
 All other trademarks are the property of their respective owners.

This data sheet contains minimum and maximum limits specified over the power supply and temperature range set forth herein. Although considered final, these specifications are subject to change, as further product development and data characterization sometimes occur.