



Technical Specification for Small Form Factor Pluggable (SFP)

SCP69N4-GL-#N-xx (No Diagnostic Monitoring)

SCP6EN4-GL-#N-xx (Diagnostic Monitoring with External Calibration)

- | | | |
|--|--|---|
| <input type="checkbox"/> 155.52Mbps | <input type="checkbox"/> 622.08Mbps | <input checked="" type="checkbox"/> other <u>Up to 1.25Gbps</u> |
| <input type="checkbox"/> Short Haul | <input type="checkbox"/> Long Haul | <input checked="" type="checkbox"/> other <u>Multi Rate</u> |
| <input type="checkbox"/> Intermediate Reach | <input type="checkbox"/> Long Reach | <input checked="" type="checkbox"/> other <u>Link Budget 22dB</u> |
| <input type="checkbox"/> Single 5.0 V | <input checked="" type="checkbox"/> Single 3.3 V | <input type="checkbox"/> other _____ |
| <input type="checkbox"/> 1.3 μm | <input type="checkbox"/> 1.55 μm | <input checked="" type="checkbox"/> other <u>CWDM (PIN)</u> |
| <input checked="" type="checkbox"/> W / Diagnostic Monitor | <input checked="" type="checkbox"/> W / O Diagnostic Monitor | |

Applicable Part Numbers :

SCP69N4-GL-AN-xx, SCP69N4-GL-BN-xx, SCP69N4-GL-CN-xx, SCP69N4-GL-XN-xx, SCP69N4-GL-YN-xx, SCP69N4-GL-ZN-xx
SCP6EN4-GL-AN-xx, SCP6EN4-GL-BN-xx, SCP6EN4-GL-CN-xx, SCP6EN4-GL-XN-xx, SCP6EN4-GL-YN-xx, SCP6EN4-GL-ZN-xx

xx:Wavelength

27: 1270nm, 29: 1290nm, 31: 1310nm, 33, 1330nm, 35, 1350nm, 37, 1370nm, 39, 1390nm, 41, 1410nm, 43, 1430nm
45: 1450nm, 47: 1470nm, 49: 1490nm, 51, 1510nm, 53, 1530nm, 55, 1550nm, 57, 1570nm, 59, 1590nm, 61, 1610nm



Sumitomo Electric reserves the right to make changes in this specification without prior notice.

Sumitomo Electric Industries, Ltd. and ExceLight Communications, Inc., have been granted license to the following patents under a license agreement with Finisar Corporation: US 5,019,769, US 6,439,918 B1

#Safety Precaution Symbols This specification uses various picture symbols to prevent possible injury to operator or other persons or damage to properties for appropriate use of the product. The symbols and definitions are as shown below. Be sure to be familiar with these symbols before reading this specification.

	Warning Wrong operation without following this instruction may lead to human death or serious injury.
	Caution Wrong operation without following this instruction may lead to human injury or property damage.

Example of picture symbols indicates prohibition of actions. Action details are explained thereafter.

indicates compulsory actions or instructions. Action details are explained thereafter.

(SCP69N4 / 6EN4-GL)

1. General

Features and applications of SCP69N4-GL and SCP6EN4-GL are listed below.

Features

- * Eighteen wavelengths CWDM Transceivers
- * Uncooled CWDM rated DFB laser transmitter
- * Compliant with SFP MSA.
- * SFF-8472 rev9 compliant diagnostic monitoring implemented.(SCP6EN4-GL-#N-xx)
- * Multiple Bit Rate Operation Up to 1.25Gbps
- * Power Supply voltage Single 3.3V
- * Compact package size 56.5 x 13.7 x 8.6mm
- * Electrical Interface AC coupled for DATA, LVTTTL for Tx Disable and open collector output for LOS and Tx Fault. Circuit ground is internally isolated from frame ground.
- * Fiber Coupled Power 0 to +5dBm
- * Input Power Range -22 to 0dBm
- * Link budget 22dB
- * Dispersion Penalty Max. 2.0dB (to 1600ps/nm)

Applications

- * Switch to Switch interface
- * Switch backbone applications
- * High speed interface for file server

2. Block Diagram

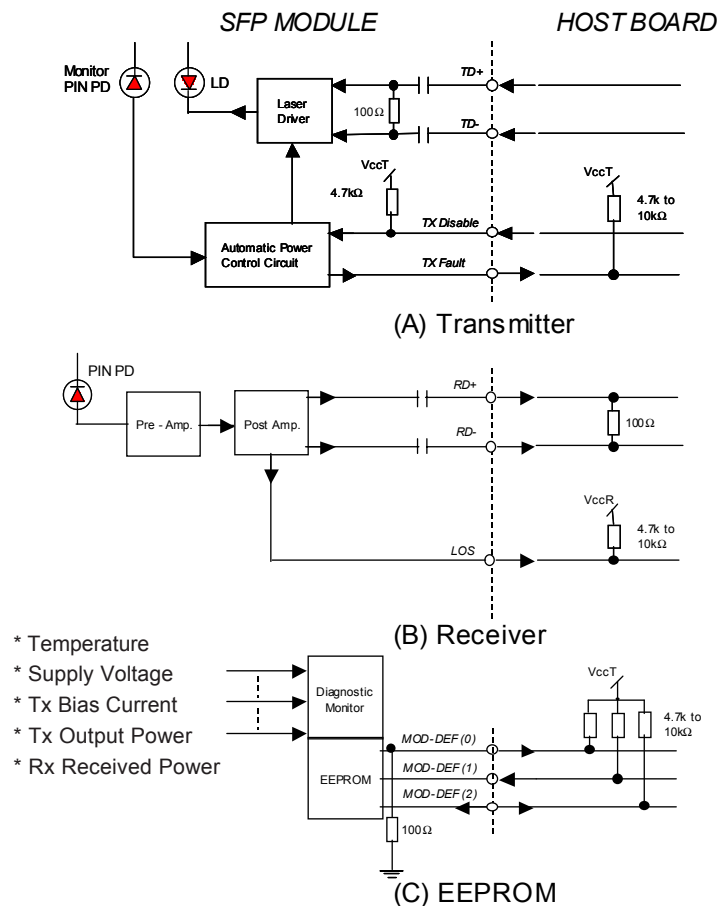

Figure 1. Block Diagram (Diagnostic Monitor is incorporated for SCP6EN4-GL-#N-xx only.)

⚠ Caution

⊘ Do not disassemble this product. Otherwise, failure, electrical shock, overheating or fire may occur.

3. Package Dimensions

All dimensions are in mm.

3.1 SCP6#N4-GL-□ N-xx (MSA Standard Actuator Type)

X,Y,Z

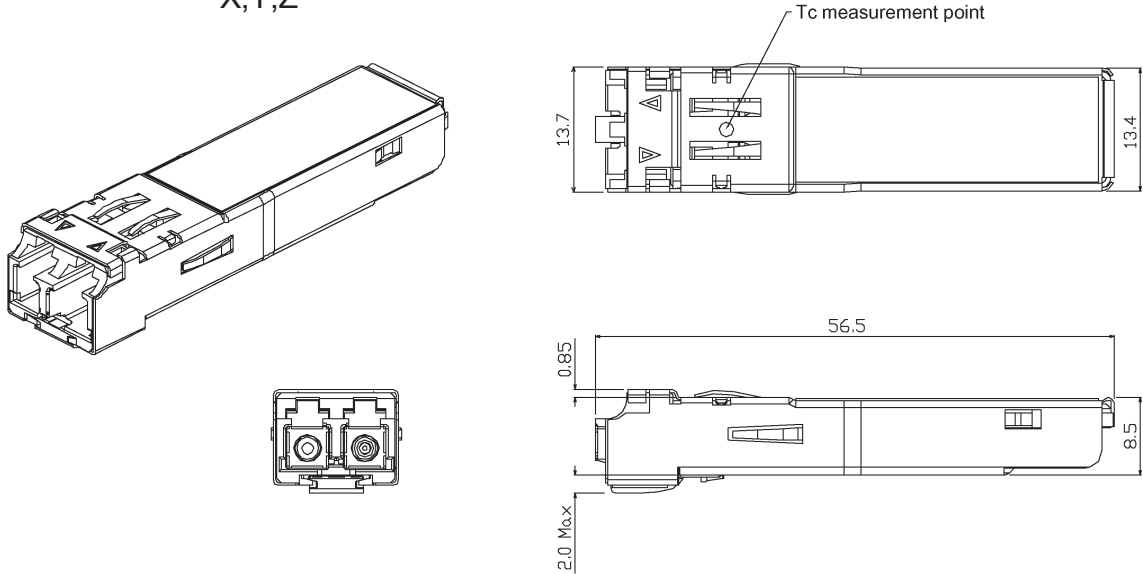

3.2 SCP6#N4-GL-□ N-xx (Bail Actuator Type)

A,B,C

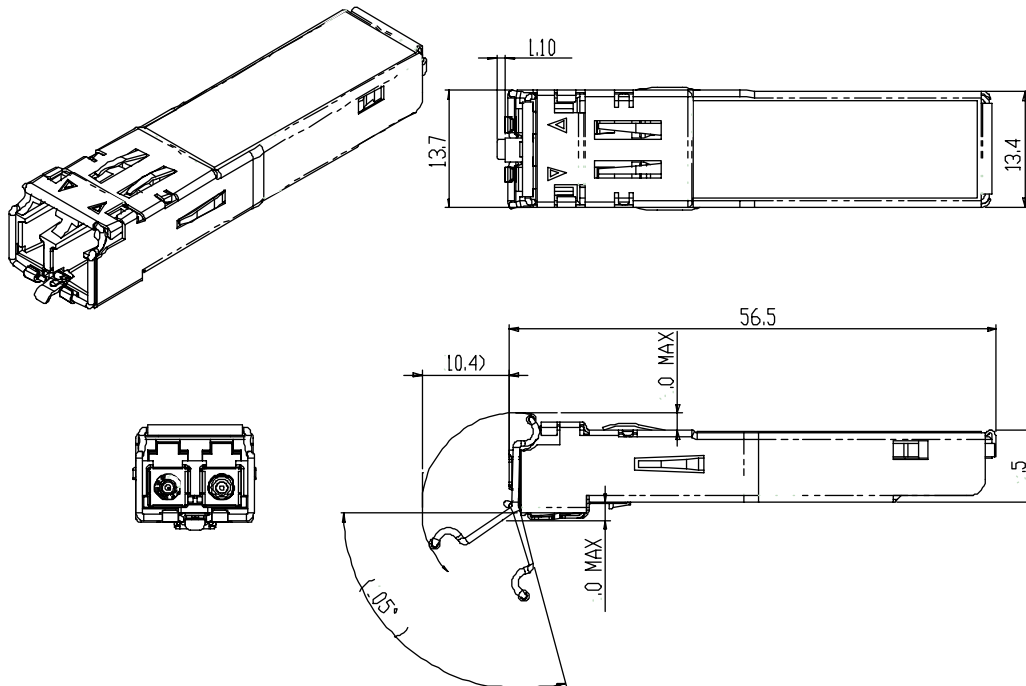

* Recommended Cage and Connector

- Top EMI Cage 1367035-1(Tyco/Electronics:1308292--AMP-04/00)
- Bottom EMI Cage 1367034-1(Tyco/Electronics:1308292--AMP-04/00)
- Host Connector 1367073-1(Tyco/Electronics:1308292--AMP-04/00)

Please refer to their latest specifications.

Figure 2. Outline Dimensions

4. Pin Assignment

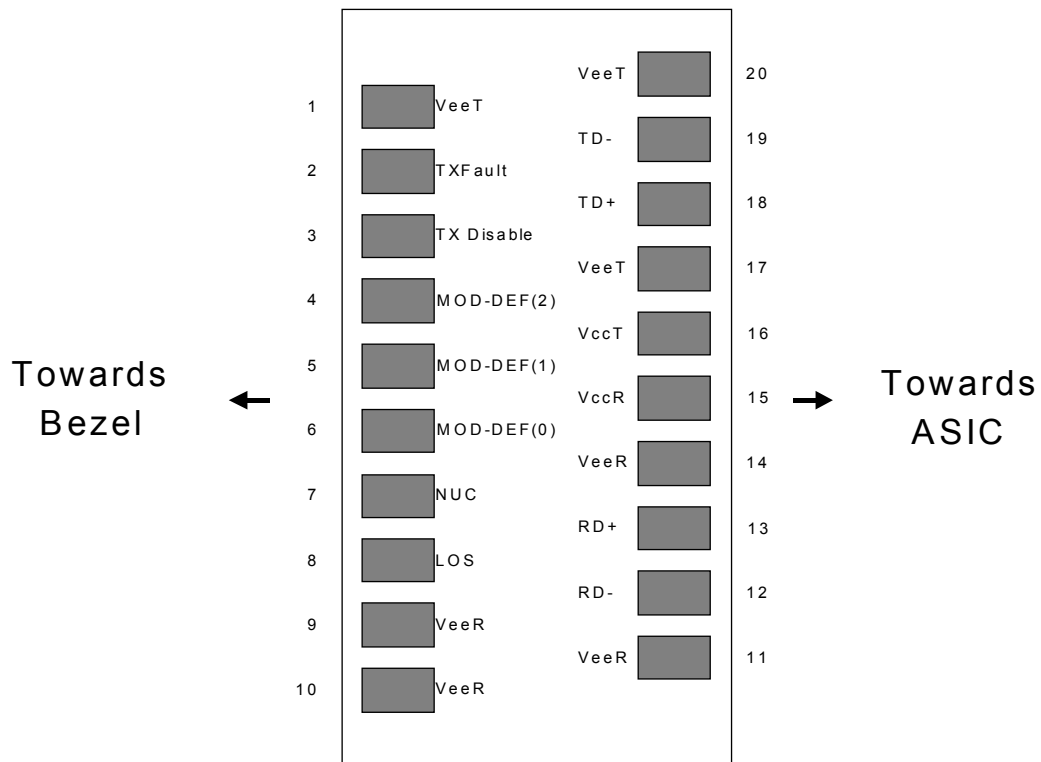

Figure 3. Diagram of Host Board Connector Block Pin Numbers and Names

Pin Num.	Name	Function	Plug Seq.	Notes
1	VeeT	Transmitter Ground	1	
2	TX Fault	Transmitter Fault Indication	3	Note 1
3	TX Disable	Transmitter Disable	3	Note 2 Module disables on high or open
4	MOD-DEF2	Module Definition 2	3	Note 3, 2 wire serial ID and Interface
5	MOD-DEF1	Module Definition 1	3	Note 3, 2 wire serial ID and Interface
6	MOD-DEF0	Module Definition 0	3	Note 3 Grounded internally via 100Ω
7	NUC	NUC	3	No User Connection, reserved for future function.
8	LOS	Loss of Signal	3	Note 4
9	VeeR	Receiver Ground	1	
10	VeeR	Receiver Ground	1	
11	VeeR	Receiver Ground	1	
12	RD-	Inv. Receiver Data Out	3	Note 5
13	RD+	Receiver Data Out	3	Note 5
14	VeeR	Receiver Ground	1	
15	VccR	Receiver Power	2	3.3V± 5%
16	VccT	Transmitter Power	2	3.3V± 5%
17	VeeT	Transmitter Ground	1	
18	TD+	Transmitter Data In	3	Note 6
19	TD-	Inv. Transmitter Data In	3	Note 6
20	VeeT	Transmitter Ground	1	

Plug Seq.: Pin engagement sequence during hot plugging.

5. Absolute Maximum Ratings

Parameter	Symbol	Min.	Typ.	Max.	Unit	Note
Storage Ambient Temperature	Ts	-40	-	85	°C	1
Operating Case Temperature	Tc	-5	-	70	°C	
Optical Input Level	Pin			3.0	dBm	
Supply Voltage	VccT,R	-0.3	-	4.0	V	
Input Voltage	Vi	0	-	VccT,R+0.3	V	2
Differential Input Voltage Swing (TD+,TD-)	Vin			2.5	Vp-p	

Notes

1. No condensation allowed. 2: For MODE-DEF (1:2)

⚠ Warning

❗ Use the product with the rated voltage described in the specification. If the voltage exceeds the maximum rating, overheating or fire may occur.

⚠ Caution

⊘ Do not store the product in the area where temperature exceeds the maximum rating, where there is too much moisture or dampness, where there is acid gas or corrosive gas, or other extreme conditions. Otherwise, failure, overheating or fire may occur.

6. Electrical Interface

(Unless otherwise specified, VccT,R = 3.135 to 3.465 V and all operating temperature shall apply.)

6-1. Operating Characteristics

Parameter	Symbol	Min.	Typ.	Max.	Unit	Note
Supply Voltage	VccT,R	3.135	3.30	3.465	V	
Power Dissipation	Pw			1000	mW	1

Note

1. 1250Mbps, PRBS2⁷-1, NRZ, 50% duty cycle data.

6-2. Transmitter side

Parameter	Symbol	Min.	Typ.	Max.	Unit	Note
Differential Input Voltage Swing (TD+,TD-)	Vin	0.5		2.4	Vp-p	1
Input Differential Impedance	Zin	80	100	120	Ω	
Tx Fault	Fault	VfaultH	2.0	VccT+0.3	V	2, 3
	Normal	VfaultL	0	0.8	V	2, 3, 4
Tx Disable	Disable	Vdi	2.0	VccT+0.3	V	5
	Enable	Vei	0	0.8	V	
Tdis Input Current	High	Ids	-1	50	μA	

Notes

- Refer to Figure 7.
- Tx Fault is pulled up to VccT with a 4.7k-10kΩ resistor on the host board.
When high, output indicates a laser fault of some kind. Low indicates normal operation.
- Refer to Ordering Information (P.20) about Tx Fault and Tx Shutdown behavior.
- Sink Current : 1mA
- Tx Disable input is internally terminated to VccT via 4.7 kΩ resistor. If pin3 is left open, Tx is disable.

6-3. Receiver side

Parameter	Symbol	Min.	Typ.	Max.	Unit	Note
Differential Output Voltage Swing (RD+,RD-)	Vout	0.5		1.2	Vp-p	1
LOS	High	Vloh	2.0	VccR+0.3	V	2
	Low	Vlol	0	0.8	V	2, 3
Data Rise / Fall Time	tr / tf			240	psec	4

Notes

- Vcc=+3.3V +/-5%, Output load resistance Rdif=100Ω. Refer to Figure1-(B).
Refer to Figure7. about definition of differential swing.
- LOS is pulled up to VccR with a 4.7k - 10kΩ resistor on the host board. Low indicates normal operation.
- Sink Current : 1mA 4. 20 to 80%, 1250Mbps, PRBS 2⁷-1, NRZ, 50% duty cycle data.

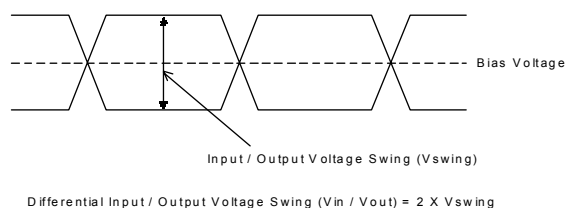

Figure 7. Definition of Differential Input / Output Voltage Swing

6-4. Module Definition

Parameter	Symbol	Min.	Typ.	Max.	Unit	Note
MOD_DEF(1:2) Input Voltage	High	Vih	0.7VccT	VccT+0.3	V	1
	Low	Vil	0	0.3VccT	V	
MOD_DEF(2) Output Voltage	High	Voh	2.0	VccT	V	1
	Low	Vol1	0	0.4	V	1, 2

Notes

- They shall be pulled up to VccT with a 4.7k - 10kΩ resistor on the host board.
- Sink Current : 3mA

7. Optical Interface

Parameter	Symbol	Min.	Typ	Max.	Units	Notes
Bit Rate Range		0.1	-	1.25	Gbps	
Average Output Power (Enable)	Po	0	-	5	dBm	
Average Output Power (Disable)	Pdis	-	-	-45	dBm	
Extinction Ratio	Er	9.0	-	-	dB	
Center Wavelength	λc (27)	1264.5	1270	1277.5	nm	1
	λc (29)	1284.5	1290	1297.5	nm	
	λc (31)	1304.5	1310	1317.5	nm	
	λc (33)	1324.5	1330	1337.5	nm	
	λc (35)	1344.5	1350	1357.5	nm	
	λc (37)	1364.5	1370	1377.5	nm	
	λc (39)	1384.5	1390	1397.5	nm	
	λc (41)	1404.5	1410	1417.5	nm	
	λc (43)	1424.5	1430	1437.5	nm	
	λc (45)	1444.5	1450	1457.5	nm	
	λc (47)	1464.5	1470	1477.5	nm	
	λc (49)	1484.5	1490	1497.5	nm	
	λc (51)	1504.5	1510	1517.5	nm	
	λc (53)	1524.5	1530	1537.5	nm	
λc (55)	1544.5	1550	1557.5	nm		
λc (57)	1564.5	1570	1577.5	nm		
λc (59)	1584.5	1590	1597.5	nm		
λc (61)	1604.5	1610	1617.5	nm		
Spectral width	Δλ	-	-	1	nm	
Side Mode Suppression Ratio		30	-	-	dB	
Eye Mask for Optical Output	Compliant with Eye Mask Defined in IEEE 802.3 standard					
Transmitter Jitter (peak to peak)	TjpkT	-	-	227	ps	1, 2
Optical Rise / Fall Time	tr / tf			260	ps	3
Dispersion Penalty	Dp	-	-	2.0	dB	4

Notes

- Measured at 1250Mbps, PRBS 2⁷-1, 50% duty cycle, NRZ.
- TP2 refers to the compliance point specified in IEEE802.3, section 38.2.1.
- These are unfiltered 20-80% values.
- Maximum dispersion values correspond to the approximate worst-case dispersion (to 1600ps/nm) at 1610nm.

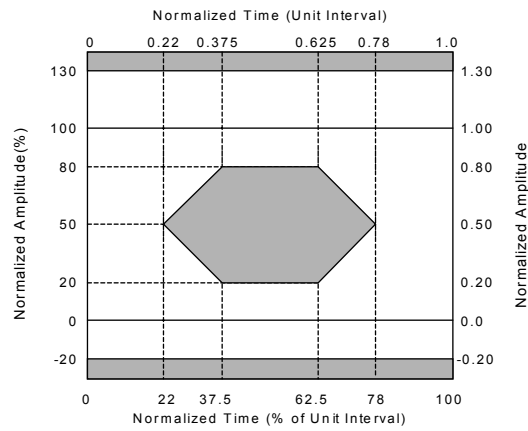

Figure 8. Eye Diagram Mask for Optical Output (IEEE 802.3)

Warning



Do not look at the laser beam projection area (e.g. end of optical connector) with naked eyes or through optical equipment while the power is supplied to this product. Otherwise, your eyes may be injured.

7-2. Receiver side

Parameter	Symbol	Min.	Typ	Max	Units	Notes
Bit Rate Range	-	0.1	-	1.25	Gbps	
Center Wavelength	-	1260	-	1620	nm	
Minimum Sensitivity (EOL)	P _{min}	-	-	-22.0	dBm	1,2
Overload	P _{max}	0	-	-	dBm	1,2
LOS Activation Level	P _{l_a}	-35.0	-	-22.5	dBm	2
LOS Deactivation Level	P _{l_d}	-34.5	-	-22.0	dBm	
LOS Hysteresis	Phys	0.5	-	6.0	dB	
Reflectance	REFr	-	-	-12.0	dB	

Notes

1. BER = 10⁻¹²

2. Worst case extinction ratio. Measured at 1.25Gbps, PRBS 2⁷-1 test pattern, NRZ, EOL

7-3. Transceiver Timing Characteristics

Parameter	Symbol	Min.	Typ.	Max.	Unit	Note
Tx Disable Assert Time	t_{off}			10	us	1
Tx Disable Negate Time	t_{on}			1	ms	2
Time to Initialize	t_{init}			300	ms	3
Tx Fault Assert Time	t_{fault}			100	us	4
Tx Disable to Reset	t_{reset}	10			us	5
LOS Assert Time	t_{loss_on}			100	us	6
LOS Deassert Time	t_{loss_off}			100	us	7
Serial ID Clock Rate	f_{serial_clock}			100	kHz	

Notes

1. Time from rising edge of TX Disable to when the optical output falls below 10% of nominal.
2. Time from falling edge of TX Disable to when the modulated optical output rises above 90% of nominal.
3. From power on. 4. Time from fault to TX fault on. 5. Time Tx Disable must be held high to reset TX_fault.
6. Time from LOS state to RX LOS assert. 7. Time from non-LOS state to RX LOS deassert.

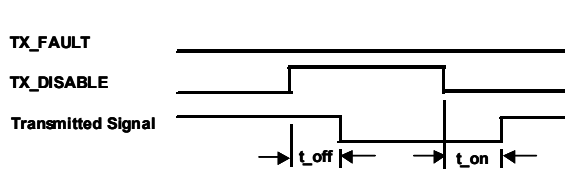

TX_DISABLE timing during normal operation.

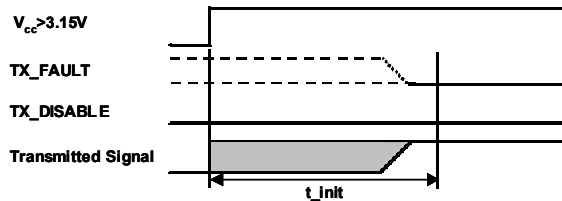

Power on initialization of SFP transceiver, TX_DISABLE negated

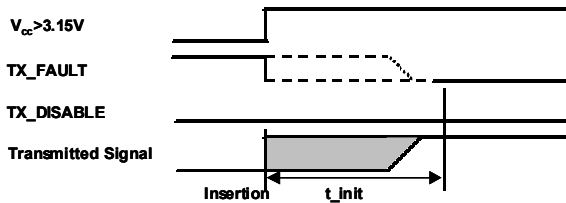

Example of initialization during hot plugging, TX_DISABLE negated

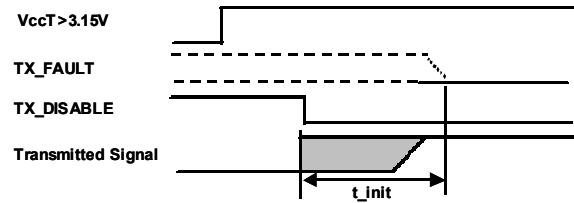

Power on initialization of SFP, TX_DISABLE asserted

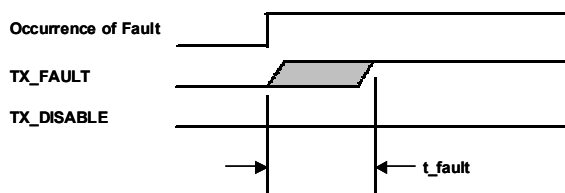

Detection of transmitter safety fault condition

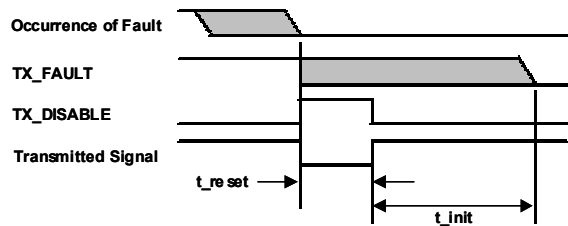

Successful recovery from transient safety fault condition (Except for Type "B" and "Y". Refer to next page.)

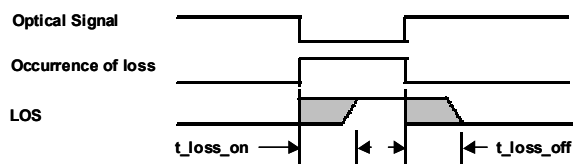

Timing of LOS detection

Figure 9. Transceiver Timing Charts

7-4. Tx_Fault / Tx Shutdown Options

SCP69N4-GL- N-xx

SCP6EN4-GL- N-xx

Actuator and Tx_Fault Type

Type	Actuator	Tx Fault	Tx Shutdown on Tx Fault
A	Bail	Latched	No
B	Bail	Not Latched	No
C	Bail	Latched	Yes
X	MSA	Latched	Yes
Y	MSA	Not Latched	No
Z	MSA	Latched	No

Type:"A" or "Z"

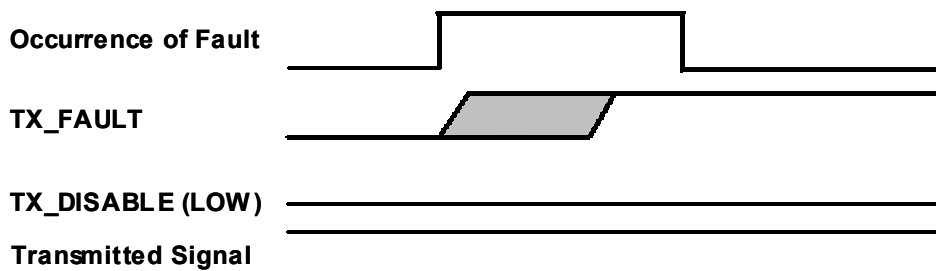

Type:"B" or "Y"

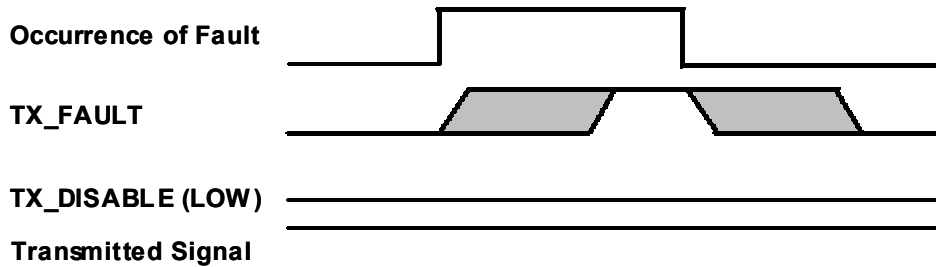

Type:"C" or "X"

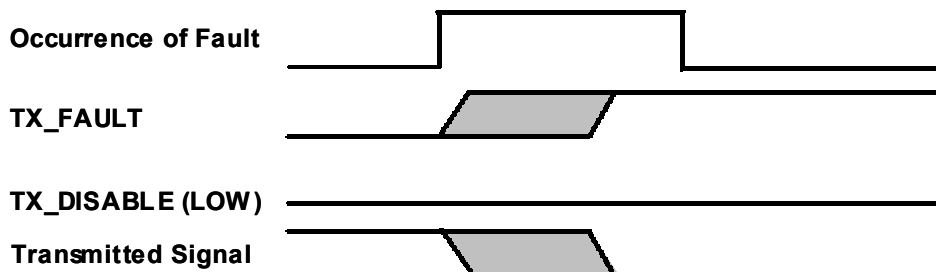

Figure 10. Part Number Identification For Tx_Fault / Tx Shutdown Behavior

8. Digital Diagnostic Memory Map

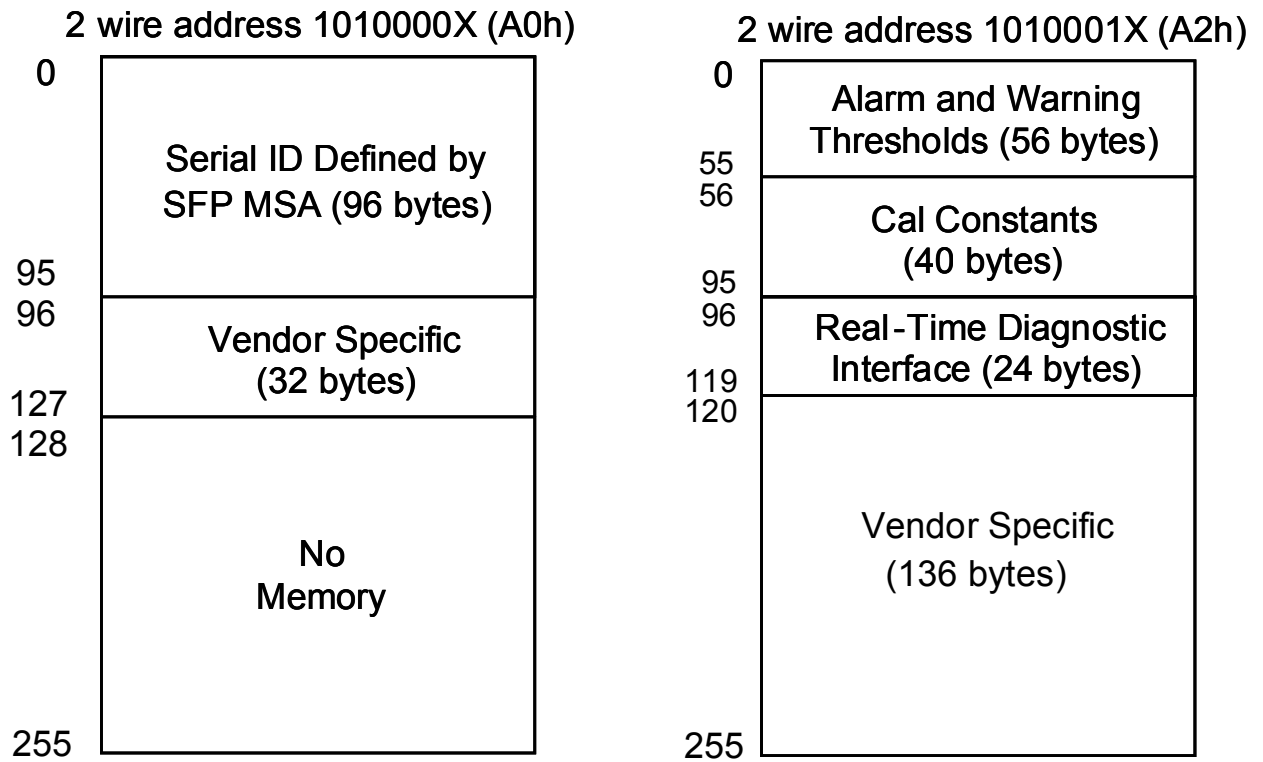

Figure 11. Digital Diagnostic Memory Map (A2h is applicable for SCP6EN4-GL-#N-xx)

9. EEPROM Serial ID Memory Contents

The data can be read using the 2-wire serial CMOS EEPROM protocol of the Atmel AT24C01A or equivalent.

2 wire address 1010000X (A0h)

Address	Name of field	Hex	ASCII	Description	Address	Name of field	Hex	ASCII	Description		
BASE ID FIELDS					EXTENDED ID FIELDS						
0	Identifier	03		SFP Transceiver	64	Options	00				
1	Ext. Identifier	04			65		1A				
2	Connector	07		LC Connector	66	BR_max	00				
3	Transceiver	0			67	BR_min	00				
4		0			68				Year		
5		0			69					Month	
6		02			1000BASE	70	Vendor SN	Note4			
7		0				71					
8		0				72					
9	0				73						
10	0				74						
11	Encoding	1		8B10B	75						
12	BR_Nominal	0D		1.25Gbps	76						
13	Reserved	0			77						
14	Length(9um) - km	50		80Km	78						
15	Length(9um)	FF			79						
16	Length(50um)	37		550m	80						
17	Length(62.5um)	37		550m	81						
18	Length(Copper)	0			82						
19	Reserved	0			83						
20	Vendor name	53	S		84	Date code	Note5				
21		75	u		85						
22		6D	m		86						
23		69	i		87						
24		74	t		88						
25		6F	o		89						
26		6D	m		90						
27		6F	o		91						
28		45	E		92	Diagnostic Monitoring Type	58(Note6)		Diagnostics(Ext.Cal)		
29		6C	l		93	Enhanced Options	B0(Note6)		Diagnostics Non-diagnostics		
30		65	e		94	SFF-8472 Compliance	01		Diagnostics Non-diagnostics		
31		63	c		95	CC_EXT	Note7				
32		74	t		VENDOR SPECIFIC ID FIELDS						
33		72	r		96	Read-only	20				
34		69	i		97		20				
35		63	c		98		20				
36	Reserved	00		99	20						
37	Vendor OUI	00		100	20						
38		00		101	20						
39		5F		102	20						
40	Vendor PN	53	S		103		20				
41		43	C		104		20				
42		50	P		105		20				
43		36	6		106		20				
44		39	9		107		20				
45		45	E		108		20				
46		4E	N		109		20				
47		34	4		110		20				
48		2D	-		111		20				
49		47	G		112		20				
50		4C	L		113		20				
51		2D	-		114		20				
52		41 to 43	A to C		115		20				
53		4E	N		116	20					
54	2D	-		117	20						
55	32,33,34,35,36	2,3,4,5,6		118	20						
56	31,33,35,37,39	1,3,5,7,9		119	20						
57	41 to 5A	A to Z		120	20						
58	Vendor rev	20		121	20						
59		20		122	20						
60		20		123	20						
61	Wavelength	Note2		124	20						
62	Reserved	00		125	20						
63	CC BASE	Note3		126	20						
				127	20						

Note1. Fiber Loss 0.35dB/km. Fiber loss budget plus all other system penalties must not exceed total system budget specification.

Note2. The laser wavelength is equal to the 16 bit integer value in nm.

1270nm: 4F6h, 1290nm: 50Ah, 1310nm: 51Eh, 1330nm: 532h, 1350nm: 546h, 1370nm: 55Ah, 1390nm: 56Eh, 1410nm: 582h, 1430nm: 596h, 1450nm: 5AAh
1470nm: 5BEh, 1490nm: 5D2h, 1510nm: 5E6h, 1530nm: 5FAh, 1550nm: 60Eh, 1570nm: 622h, 1590nm: 636h, 1610nm: 64Ah

Note3. Address 63 is check sum of bytes 0 - 62. Note4. Address 68 - 83 is Vendor serial Number.

Note5. Address 84 - 91 is Date Code. Note6. Refer to Section 10.(Enhanced Monitoring Functions)

Note7. Address 95 is check sum of bytes 64 - 94.

10. Enhanced Monitoring Functions (SCP6EN4-GL-#N-xx)

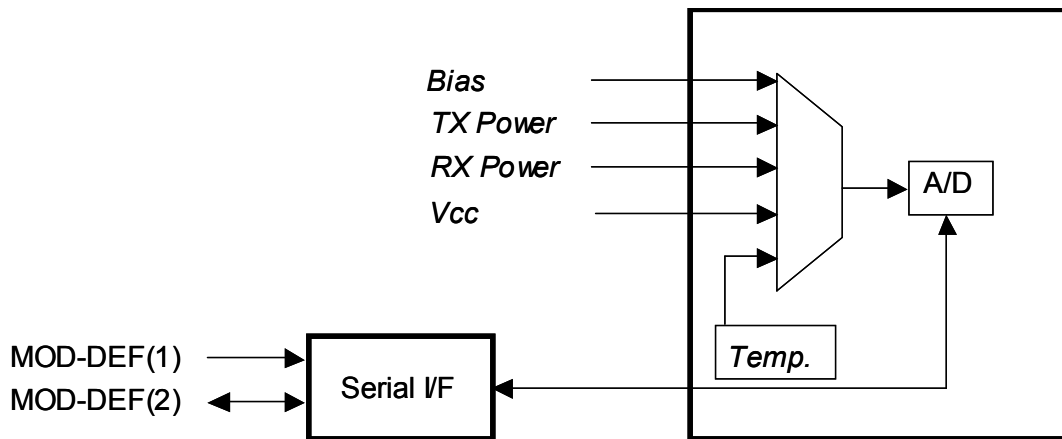

Figure 12. Block Diagram

Diagnostic Monitoring Type, 2 wire address A0h

Data Address	Bits	Description	Status(SEI)
92	7	Reserved for legacy diagnostic implementations. Must be '0' for compliance with SFF-8472.	0
92	6	Digital diagnostic monitoring implemented (described in SFF-8472). Must be '1' for compliance with SFF-8472.	1
92	5	Internally Calibrated	0
92	4	Externally Calibrated	1
92	3	Received power measurement type 0 = OMA, 1 = Average Power	1
92	2	Address change required. (Refer to SFF-8472)	0
92	1-0	Reserved	0

Enhanced Options, 2 wire address A0h

Data Address	Bits	Description	Status(SEI)
93	7	Optional Alarm/warning flags implemented for all monitored quantities	1
93	6	Optional Soft TX_DISABLE control and monitoring implemented	0
93	5	Optional Soft TX_FAULT monitoring implemented	1
93	4	Optional Soft RX_LOS monitoring implemented	1
93	3	Optional Soft RATE_SELECT control and monitoring implemented	0
93	2-0	Reserved	0

11. Calibration Calculation (SCP6EN4-GL-#N-xx)

Calibration constants for External Calibration Option, 2 wire address A2h

Address	#Bytes	Name	Description
56-59	4	RP ₄	Single precision floating-point calibration data for received power. Byte 56 is MSB. Byte 59 is LSB.
60-63	4	RP ₃	Single precision floating-point calibration data for received power. Byte 60 is MSB. Byte 63 is LSB.
64-67	4	RP ₂	Single precision floating-point calibration data for received power. Byte 64 is MSB. Byte 67 is LSB.
68-71	4	RP ₁	Single precision floating-point calibration data for received power. Byte 68 is MSB. Byte 71 is LSB.
72-75	4	RP ₀	Single precision floating-point calibration data for received power. Byte 72 is MSB. Byte 75 is LSB.
76-77	2	I _{SLOPE}	Unsigned fixed-point calibration data for laser bias current. Byte 76 is MSB. Byte 77 is LSB.
78-79	2	I _{OFFSET}	16-bit signed 2's complement calibration data for laser bias current. Byte 78 is MSB. Byte 79 is LSB.
80-81	2	TP _{SLOPE}	Unsigned fixed-point calibration data for laser output power. Byte 80 is MSB. Byte 81 is LSB.
82-83	2	TP _{OFFSET}	16-bit signed 2's complement calibration data for laser output power. Byte 82 is MSB. Byte 83 is LSB.
84-85	2	T _{SLOPE}	Unsigned fixed-point calibration data for transceiver temperature. Byte 84 is MSB. Byte 85 is LSB.
86-87	2	T _{OFFSET}	16-bit signed 2's complement calibration data for transceiver temperature. Byte 86 is MSB. Byte 87 is LSB.
88-89	2	V _{SLOPE}	Unsigned fixed-point calibration data for supply voltage. Byte 88 is MSB. Byte 89 is LSB.
90-91	2	V _{OFFSET}	16-bit signed 2's complement calibration data for supply voltage. Byte 90 is MSB. Byte 91 is LSB.
92-94	3	Reserved	Reserved
95	1	Checksum	Byte 95 contains the low order 8 bits of the sum at data address bytes 0-94.

Transceiver temperature: Temperature, T, is given by

$$T = T_{SLOPE} * T_{AD} + T_{OFFSET}$$

Where T_{AD} is 16-bit signed 2's complement A/D value at bytes 96-97, T_{SLOPE} is unsigned fixed-point value at bytes 84-85 and T_{OFFSET} is signed 2's complement value with LSB equal to 1/256 deg-C at bytes 86-87. The result, T, is 16-bit signed 2's complement value with LSB equal to 1/256 deg-C. The monitored output is the junction temperature of the diode inside the transceiver, hence, there is some discrepancy between the output and transceiver case temperature of the point illustrated in section 3 mechanical dimension.

Supply voltage: Voltage, V, is given by

$$V = V_{SLOPE} * V_{AD} + V_{OFFSET}$$

Where V_{AD} is 16-bit unsigned A/D value at bytes 98-99, V_{SLOPE} is unsigned fixed-point value at bytes 88-89 and V_{OFFSET} is signed 2's complement value with LSB equal to 100 μV at bytes 90-91. The result, V, is 16-bit unsigned value with LSB equal to 100 μV.

Laser bias current: Current, I, is given by

$$I = I_{\text{SLOPE}} * I_{\text{AD}} + I_{\text{OFFSET}}$$

Where I_{AD} is 16-bit unsigned A/D value at bytes 100-101, I_{SLOPE} is unsigned fixed-point value at bytes 76-77 and I_{OFFSET} is signed 2's complement value with LSB equal to 2 μA at bytes 78-79. The result, I, is 16-bit unsigned value with LSB equal to 2 μA .

Laser output power: Power, TP, is given by

$$TP = TP_{\text{SLOPE}} * TP_{\text{AD}} + TP_{\text{OFFSET}}$$

Where TP_{AD} is 16-bit unsigned A/D value at bytes 102-103, TP_{SLOPE} is unsigned fixed-point value at bytes 80-81 and TP_{OFFSET} is signed 2's complement value with LSB equal to 0.1 μW at bytes 82-83. The result, TP, is 16-bit unsigned value with LSB equal to 0.1 μW .

Received power: Power, RP, is given by

$$RP = RP_4 * RP_{\text{AD}}^4 + RP_3 * RP_{\text{AD}}^3 + RP_2 * RP_{\text{AD}}^2 + RP_1 * RP_{\text{AD}} + RP_0$$

Where RP_{AD} is 16-bit unsigned A/D value at bytes 104-105 and RP_4 , RP_3 , RP_2 , RP_1 and RP_0 are single precision floating-point values at bytes 56-75. The result, RP, is 16-bit unsigned value with LSB equal to 0.1 μW .

A/D Accuracy, 2 wire address A2h

Data Address	Parameter	Accuracy	Units Display	Note
96-97	Temperature	+/-3 deg-C.	Signed 2's complement interger deg.	Junction Temperature of Monitoring IC.
98-99	Vcc	+/-3%	x 10 μ Volt	-
100-101	TX Bias	+/-10%	x 2mA	Specified by nominal value
102-103	TX Power	+/-3dB	x 0.1 μ W	0 to 5dBm
104-105	RX Power	+/-3dB (-22 to 0dBm)	x 0.1 μ W	At specifed Transmitter wavelength (Section 7-1)

12. A/D Values and Status (SCP6EN4-GL-#N-xx)

Converted analog values, 2wire address A2h

Byte	Bit	Name	Description
96	All	Temperature MSB	Signed 2's complement integer temperature(-40 to +125C) Based on internal temperature measurement
97	All	Temperature LSB	Fractional part of temperature(count/256)
98	All	Vcc MSB	Internally measured supply voltage in transceiver. Actual voltage is full 16 bit value *100uVolt.(Yields range of 0-6.55V)
99	All	Vcc LSB	
100	All	TX Bias MSB	Measured Laser Bias Current in mA. Bias current is full 16 bit value *2μA.(Full range of 0-131mA)
101	All	TX Bias LSB	
102	All	TX Power MSB	Measured TX output power in mW . TX power is full 16 bit value*0.1μW.(Full range of -40 to+8.2dBm)
103	All	TX Power LSB	
104	All	RX Power MSB	Measured RX input power in mW . RX power is full 16 bit value*0.1μW.(Full range of -40 to+8.2dBm)
105	All	RX Power LSB	
106-109	All	Reserved	

Optional Status Bits, 2wire address A2h

Byte	Bit	Name	Description
110	0	Data_Ready_Bar	Indicates transceiver has achieved power up and data is ready. Bit remains high until data is ready to be read at which time the device sets the bit low.

13. Alarm and Warning Flags (SCP6EN4-GL-#N-xx)

Alarm and Warning Flags, 2wire address A2h

Byte	Bit	Name	Description
112	7	Temp High Alarm	Set when internal temperature exceeds high alarm level.
112	6	Temp Low Alarm	Set when internal temperature is below low alarm level.
112	5	Vcc High Alarm	Set when internal supply voltage exceeds high alarm level.
112	4	Vcc Low Alarm	Set when internal supply voltage is below low alarm level.
112	3	TX Bias High Alarm	Set when TX Bias current exceeds high alarm level.
112	2	TX Bias Low Alarm	Set when TX Bias current is below low alarm level.
112	1	TX Power High Alarm	Set when TX output power exceeds high alarm level.
112	0	TX Power Low Alarm	Set when TX output power is below low alarm level.
113	7	RX Power High Alarm	Set when Received Power exceeds high alarm level.
113	6	RX Power Low Alarm	Set when Received Power is below low alarm level.
113	5-0	Reserved	
114	All	Reserved	
115	All	Reserved	
116	7	Temp High Warning	Set when internal temperature exceeds high warning level.
116	6	Temp Low Warning	Set when internal temperature is below low warning level.
116	5	Vcc High Warning	Set when internal supply voltage exceeds high warning level.
116	4	Vcc Low Warning	Set when internal supply voltage is below low warning level.
116	3	TX Bias High Warning	Set when TX Bias current exceeds high warning level.
116	2	TX Bias Low Warning	Set when TX Bias current is below low warning level.
116	1	TX Power High Warning	Set when TX output power exceeds high warning level.
116	0	TX Power Low Warning	Set when TX output power is below low warning level.
117	7	RX Power High Warning	Set when Received Power exceeds high warning level.
117	6	RX Power Low Warning	Set when Received Power is below low warning level.
117	5-0	Reserved	
118	All	Reserved	
119	All	Reserved	

14. Recommended Interface Circuit

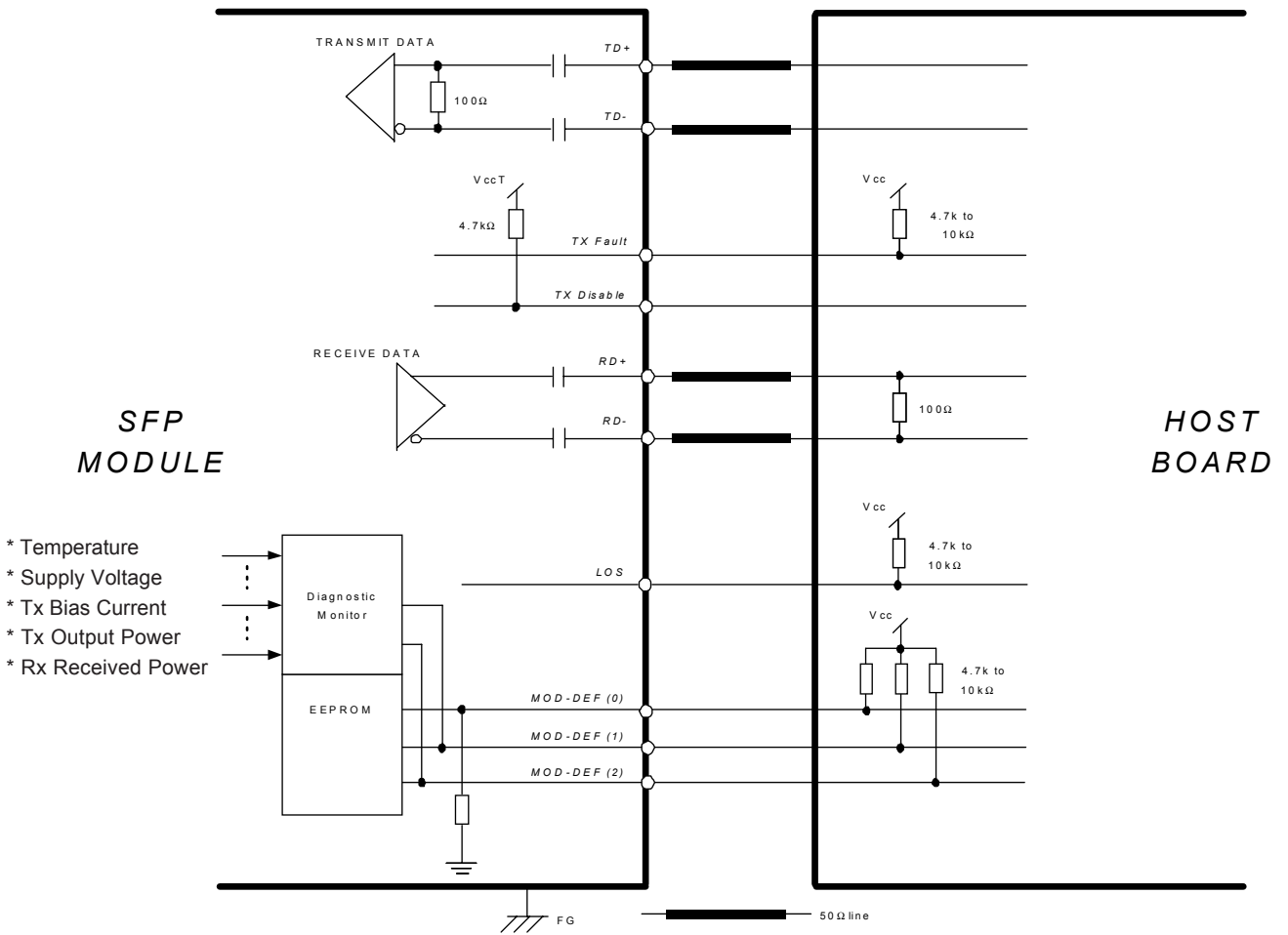

Figure 13. Recommended Interface Circuit (Diagnostic Monitor is incorporated for SCP6EN4-GL-#N-xx only.)

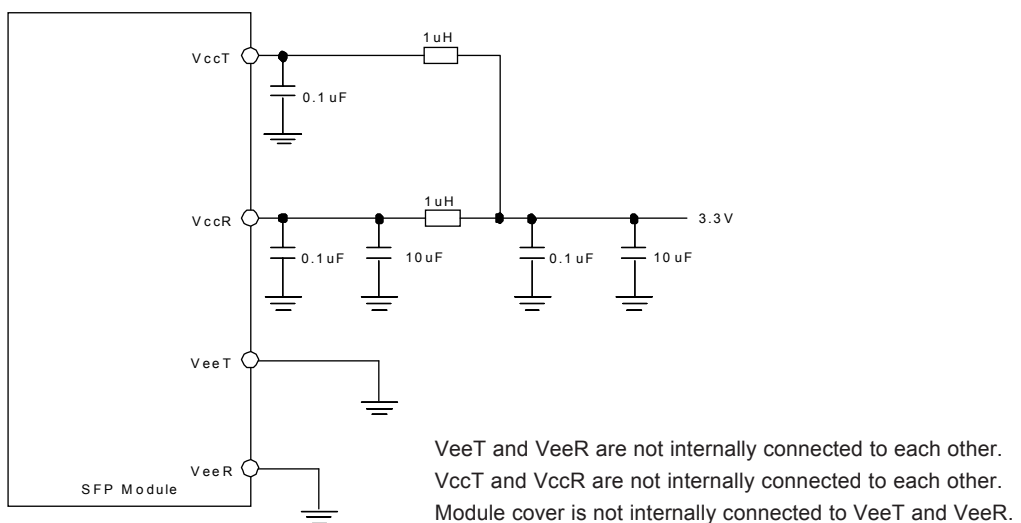
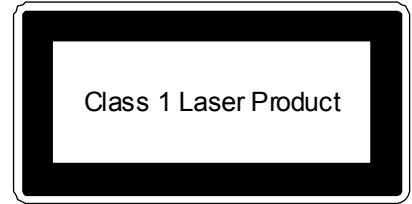

Figure 14. Recommended Supply Filtering Network

15. Laser Safety

This product uses a semiconductor laser system and the product with center wavelength $\lambda_c(41)$ to $\lambda_c(61)$ is a laser class 1 product acceptable FDA, complies with 21CFR 1040. 10 and 1040.11. Also this product is a laser class 1 product acceptable IEC 60825.



⚠ Caution	
⊘	If this product is used under conditions not recommended in the specification or this product is used with unauthorized revision, classification for laser product safety standard is invalid. Classify the product again at your responsibility and take appropriate actions.

16. Other Precaution

Under such a strong vibration environment as in automobile, the performance and reliability are not guaranteed. The governmental approval is required to export this product to other countries. To dispose of these components, the appropriate procedure should be taken to prevent illegal exportation.

This module must be handled, used and disposed of according to your company's safe working practice.

⚠ Warning	
⊘	Do not put this product or components of this product into your mouth. This product contains material harmful to health.

⚠ Caution.	
⊘	Dispose this product or equipment including this product properly as an industrial waste according to the regulations.

17. Ordering Information

SCP6[a]N4 - GL -[b] N-[c] [d]

Wavelength

27: 1270nm	45: 1450nm
29: 1290nm	47: 1470nm
31: 1310nm	49: 1490nm
33: 1330nm	51: 1510nm
35: 1350nm	53: 1530nm
37: 1370nm	55: 1550nm
39: 1390nm	57: 1570nm
41: 1410nm	59: 1590nm
43: 1430nm	61: 1610nm

Actuator and Tx Fault Type

Type	Actuator	Tx Fault	Tx Shutdown on Tx Fault	Part Number on Label
A	Bail	Latched	No	SCP6[a]N4-GL-AN-[c][d]
B	Bail	Not Latched	No	SCP6[a]N4-GL-BN-[c][d]
C	Bail	Latched	Yes	SCP6[a]N4-GL-CN-[c][d]
X	MSA	Latched	Yes	SCP6[a]N4-GL-XN-[c][d]
Y	MSA	Not Latched	No	SCP6[a]N4-GL-YN-[c][d]
Z	MSA	Latched	No	SCP6[a]N4-GL-ZN-[c][d]

Diagnostic Monitor / Calibration type

9: No Diagnostic Monitoring
 E: Diagnostic Monitoring with External Calibration

18. Bail Color

wavelength	c	d	Bail color
1270nm	27		Light purple
1290nm	29		Sky blue
1310nm	31		Yellow Green
1330nm	33		Yellow Ocher
1350nm	35		Pink
1370nm	37		Beige
1390nm	39		white
1410nm	41		Silver
1430nm	43		Black
1450nm	45		Yellow Orange
1470nm	47		Gray
1490nm	49		Violet
1510nm	51		Blue
1530nm	53		Green
1550nm	55		Yellow
1570nm	57		Orange
1590nm	59		Red
1610nm	61		Brown

19. For More Information

U.S.A.

ExceLight Communications

4021 Stirrup Creek Drive, Suite 200 Durham, NC 27703 USA

Tel. +1-919-361-1600 / Fax. +1-919-361-1619

E-mail: info@excelight.com<http://www.excelight.com>

Europe

Sumitomo Electric Europe Ltd.

220 Centennial Park, Elstree, Herts, WD6 3SL UK

Tel. +44-208-953-8681 / Fax. +44-208-207-5950

E-mail: photonics@sumielectric.com<http://www.sumielectric.com>

Japan

Sumitomo Electric Industries, Ltd.

1 Taya-cho, Sakae-ku, Yokohama, 244-8588 Japan

Tel. +81-45-853-7154 / Fax. +81-45-851-1932

E-mail: product-info@ppd.sei.co.jphttp://www.sei.co.jp/Electro-optic/index_e.html

(SCP69N4 / 6EN4-GL)