

Digital transistors (built-in resistors)

DTA114YM / DTA114YH / DTA114YE / DTA114YUA / DTA114YKA / DTA114YSA

●Features

- 1) Built-in bias resistors enable the configuration of an inverter circuit without connecting external input resistors (see equivalent circuit).
- 2) The bias resistors consist of thin-film resistors with complete isolation to allow positive biasing of the input. They also have the advantage of almost completely eliminating parasitic effects.
- 3) Only the on/off conditions need to be set for operation, making device design easy.

●Equivalent circuit

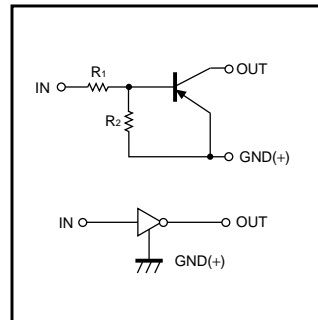

●Structure

PNP digital transistor
(Built-in resistor type)

●External dimensions (Units : mm)

<p>DTA114YM</p> <p>ROHM : VMT3 Abbreviated symbol : 54</p> <p>(1) IN (2) GND (3) OUT</p>	<p>DTA114YH</p> <p>ROHM : EMT3 Flat lead EIAJ : SC-89 Abbreviated symbol : 54</p> <p>Each lead has same dimensions</p> <p>(1) IN (2) GND (3) OUT</p>
<p>DTA114YE</p> <p>ROHM : EMT3 Abbreviated symbol : 54</p> <p>(1) GND (2) IN (3) OUT</p>	<p>DTA114YUA</p> <p>ROHM : UMT3 EIAJ : SC-70 Abbreviated symbol : 54</p> <p>All terminals have same dimensions</p> <p>(1) GND (2) IN (3) OUT</p>
<p>DTA114YKA</p> <p>ROHM : SMT3 EIAJ : SC-59 Abbreviated symbol : 54</p> <p>All terminals have same dimensions</p> <p>(1) GND (2) IN (3) OUT</p>	<p>DTA114YSA</p> <p>ROHM : SPT EIAJ : SC-72 Abbreviated symbol : 54</p> <p>(1) GND (2) OUT (3) IN</p>

DTA114YM / DTA114YH / DTA114YE / DTA114YUA DTA114YKA / DTA114YSA

Transistors

●Absolute maximum ratings (Ta=25°C)

Parameter	Symbol	Limits(DTA114Y□)						Unit
		M	H	E	UA	KA	SA	
Supply voltage	V _{CC}	-50						V
Input voltage	V _i	-40~+6						V
Output current	I _o	-70						mA
	I _{c(Max.)}	-100						
Power dissipation	P _d	150		200		300		mW
Junction temperature	T _j	150						°C
Storage temperature	T _{stg}	-55~+150						°C

●Electrical characteristics (Ta=25°C)

Parameter	Symbol	Min.	Typ.	Max.	Unit	Conditions
Input voltage	V _{i(off)}	-	-	-0.3	V	V _{CC} =-5V, I _o =-100μA
	V _{i(on)}	-1.4	-	-		V _o =-0.3V, I _o =-1mA
Output voltage	V _{o(on)}	-	-0.1	-0.3	V	I _o /I _E =-5mA/-0.25mA
Input current	I _i	-	-	-0.88	mA	V _i =-5V
Output current	I _{o(off)}	-	-	-0.5	μA	V _{CC} =-50V, V _i =0V
DC current gain	G _i	68	-	-	-	V _o =-5V, I _o =-5mA
Input resistance	R ₁	7	10	13	kΩ	-
Resistance ratio	R ₂ /R ₁	3.7	4.7	5.7	-	-
Transition frequency	f _T	-	250	-	MHz	V _{CE} =-10V, I _E =5mA, f=100MHz *

* Transition frequency of the device

●Packaging specifications

Type	Package	VMT3	EMT3 Flat lead	EMT3	UMT3	SMT3	SPT
	Packaging type	Taping	Taping	Taping	Taping	Taping	Taping
	Code	T2L	T2L	TL	T106	T146	TP
	Basic ordering unit (pieces)	8000	8000	3000	3000	3000	5000
DTA114YM	○	-	-	-	-	-	-
DTA114YH	-	○	-	-	-	-	-
DTA114YE	-	-	○	-	-	-	-
DTA114YUA	-	-	-	○	-	-	-
DTA114YKA	-	-	-	-	○	-	-
DTA114YSA	-	-	-	-	-	○	-

DTA114YM / DTA114YH / DTA114YE / DTA114YUA
DTA114YKA / DTA114YSA

Transistors

●Electrical characteristic curves

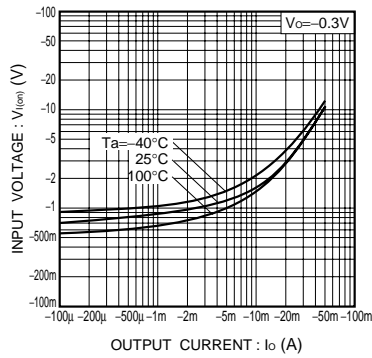

Fig.1 Input voltage vs. output current (ON characteristics)

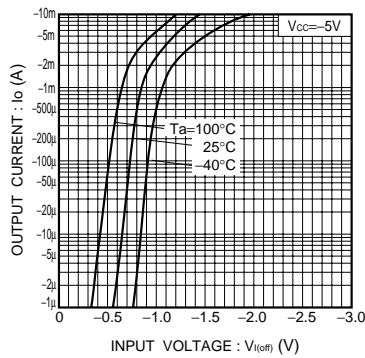

Fig.2 Output current vs. input voltage (OFF characteristics)

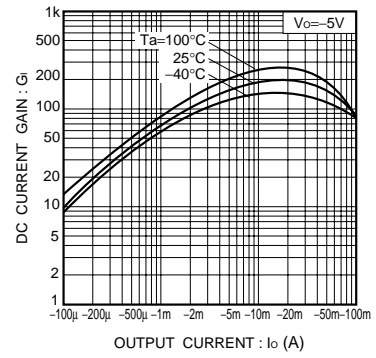

Fig.3 DC current gain vs. output current

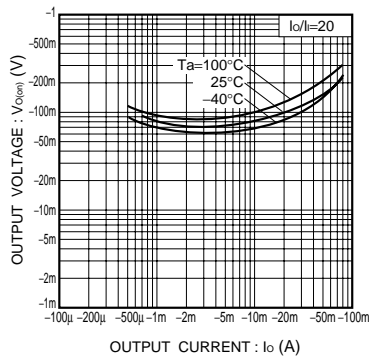

Fig.4 Output voltage vs. output current