

Technical Data Sheet

1.9mm Round Subminiature Lead LEDs

95-21UYOC/S530-XX/TRXX

Features

- Package in 12mm tape on 7" diameter reels.
- Compatible with automatic placement equipment.
- EIA Std. package.
- Mono-color type.
- Pb-free
- The product itself will remain within RoHS compliant version.

Descriptions

- The 95-21 SMD taping is much smaller than leaded components . Thus enable smaller board size. Higher packing density. Reduced storage space and finally smaller equipment to be obtained.
- Besides, light weight makes them ideal for miniature applications.
- Furthermore by automation assembly machines the accuracy is anticipated.

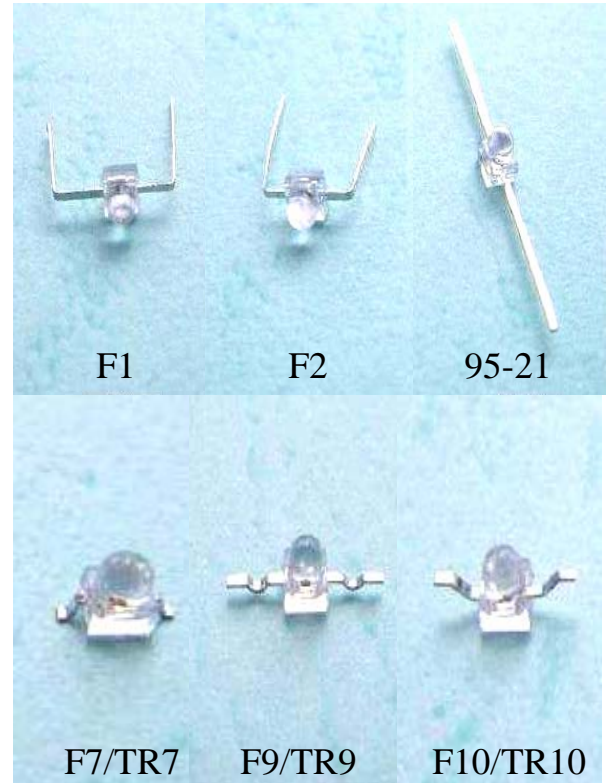

Applications

- Small indicator for indoor applications.
- Flat backlight for LCD, switches and symbols.
- Indicator and backlight in office equipment.
- Indicator and backlight for battery driven equipment.
- Indicator and backlight for audio and video equipment.
- Automotive : backlighting in dashboards and switches.
- Telecommunication : indicator and backlighting in telephone and fax.

Device Selection Guide

Chip		Lens Color
Material	Emitted Color	
AlGaInP	Super Yellow Orange	Water Clear

95-21UYOC/S530-XX/TRXX

Package Outline Dimensions

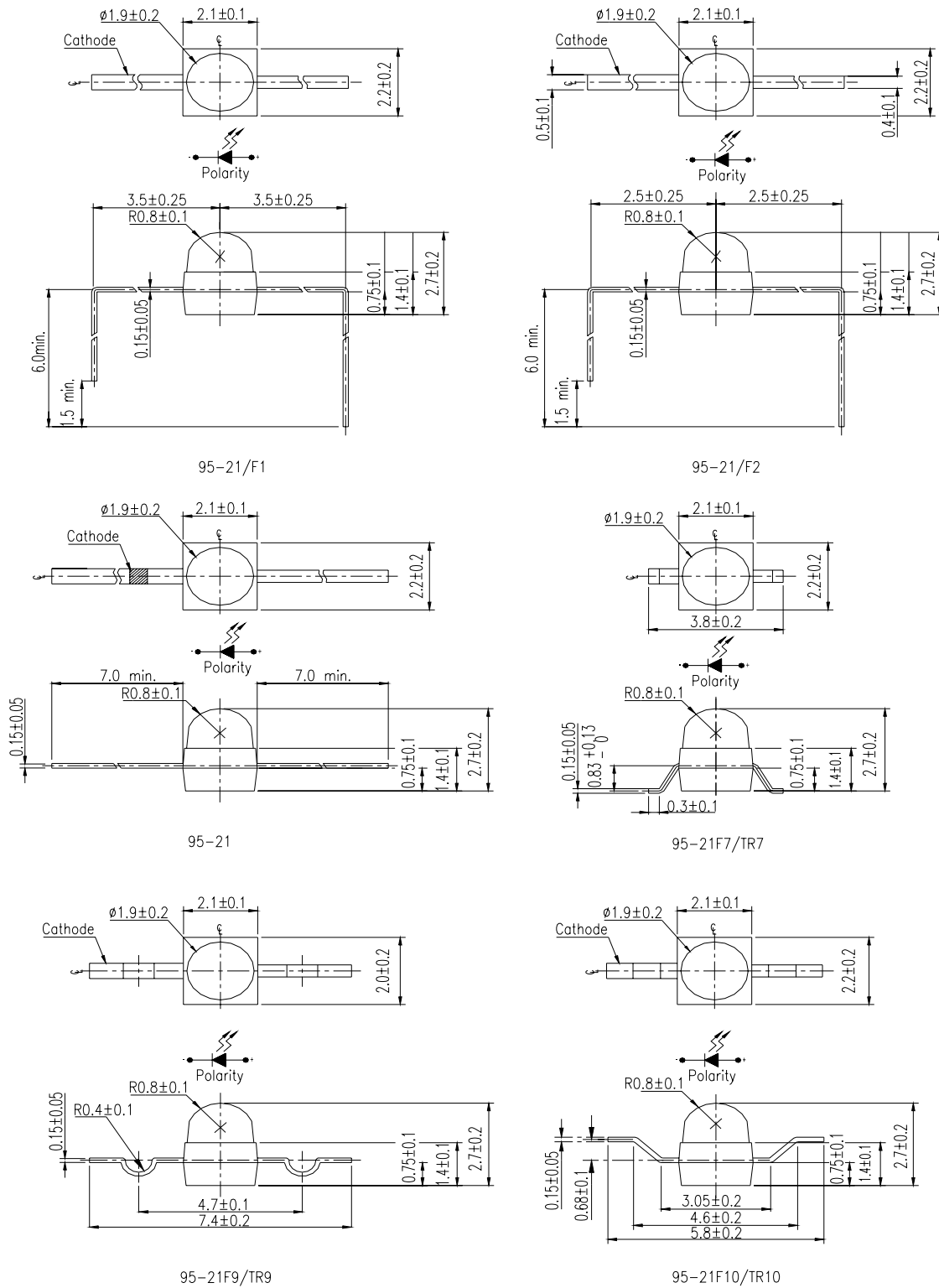

Note: The tolerances unless mentioned is ± 0.1 mm ,Unit = mm

Absolute Maximum Ratings (Ta=25°C)

Parameter	Symbol	Rating	Unit
Reverse Voltage	V _R	5	V
Forward Current	I _F	25	mA
Operating Temperature	T _{opr}	-40 ~ +85	°C
Storage Temperature	T _{stg}	-40 ~ +100	°C
Soldering Temperature	T _{sol}	260(for 5 second)	°C
Electrostatic Discharge	ESD	2000	V
Power Dissipation	P _d	60	mW
Peak Forward Current (Duty 1/10 @ 1KHz)	I _{FP}	60	mA

95-21UYOC/S530-XX/TRXX

Electro-Optical Characteristics (Ta=25°C)

Parameter	Symbol	Chip Rank	MIN.	TYP.	MAX.	Unit	Condition			
Luminous Intensity	IV	A2	----	32	----	mcd	IF=2mA			
			198	496	----		IF=20mA			
		A3	----	43	----		IF=2mA			
			463	714	----		IF=20mA			
		A4	----	54	----		IF=2mA			
			661	892	----		IF=20mA			
		A5	----	69	----		IF=2mA			
			793	1156	----		IF=20mA			
		A6	----	87	----		IF=2mA			
			991	1454	----		IF=20mA			
		Viewing Angle	$2\theta 1/2$	----	----		25	----	deg	IF=20mA
		Peak Wavelength	λp	----	----		611	----	nm	
Dominant Wavelength	λd	----	----	605	----	nm				
Spectrum Radiation Bandwidth	$\Delta\lambda$	----	----	17	----	nm				
Forward Voltage	VF	----	----	2.0	2.4	V				
Reverse Current	IR	----	----	----	10	μE	VR=5V			

*95-21UYOC/S530-XX / XXX

1 2

1:Chip Rank

2:Packing Method:

(1) None,F1,F2, F7,F9,F10 : Bulk

(2) TR7,TR9,TR10 : Taping

Typical Electro-Optical Characteristics Curves

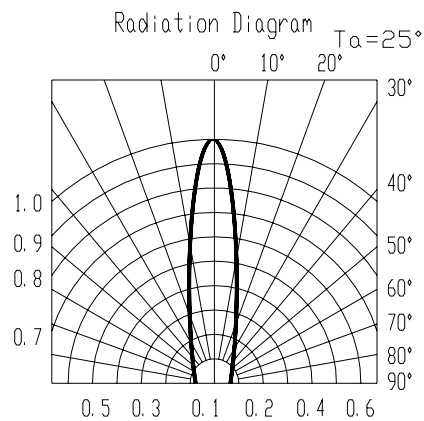
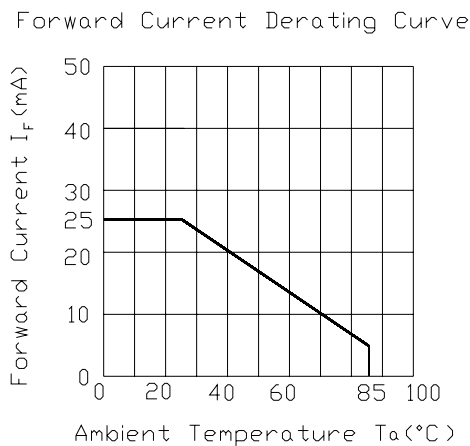
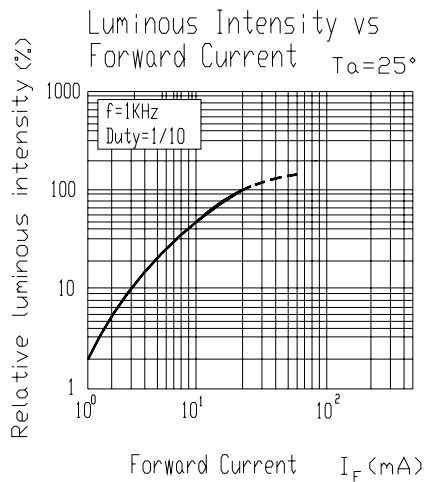
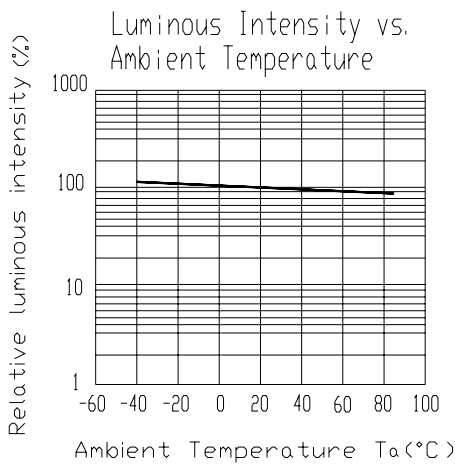
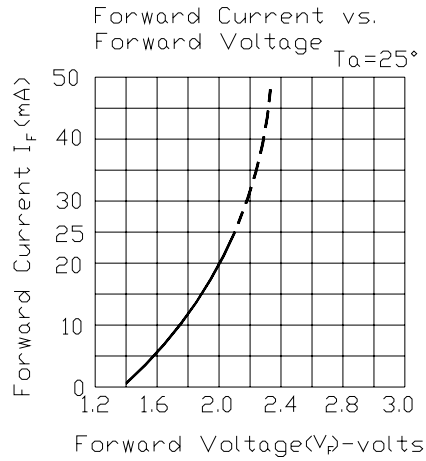
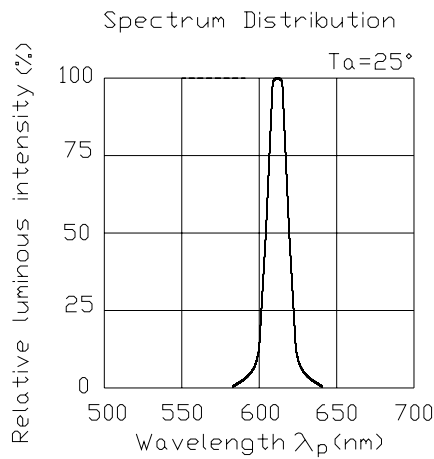

Label explanation

CAT: Luminous Intensity Rank

HUE: Dom. Wavelength Rank

REF: Forward Voltage Rank

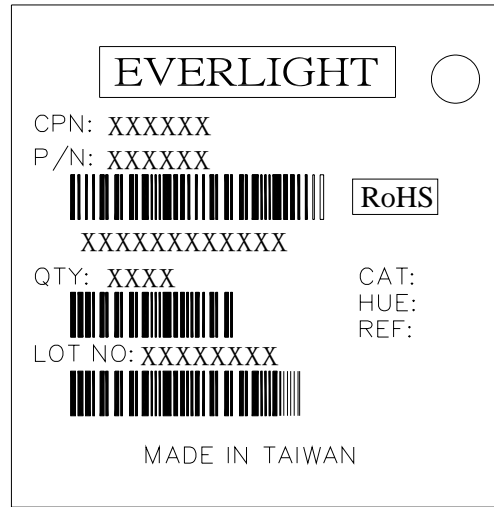

Reel & Carrier Tape Dimensions

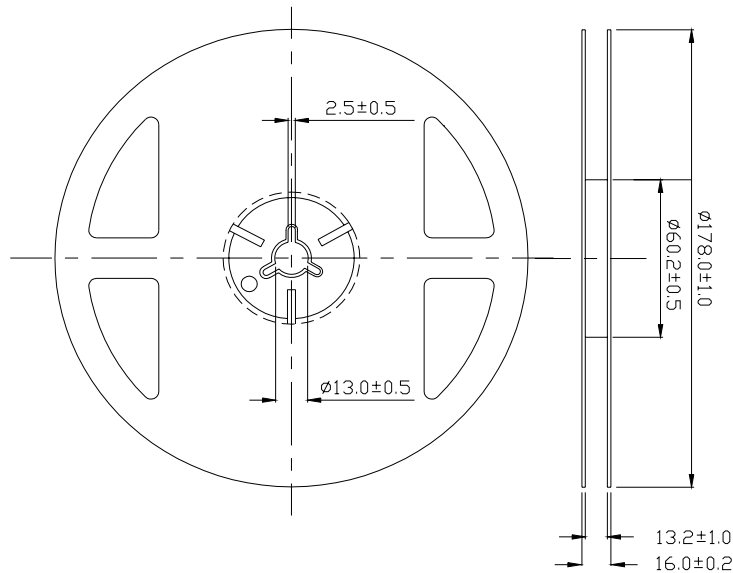

Loaded quantity per reel 1000 PCS/reel

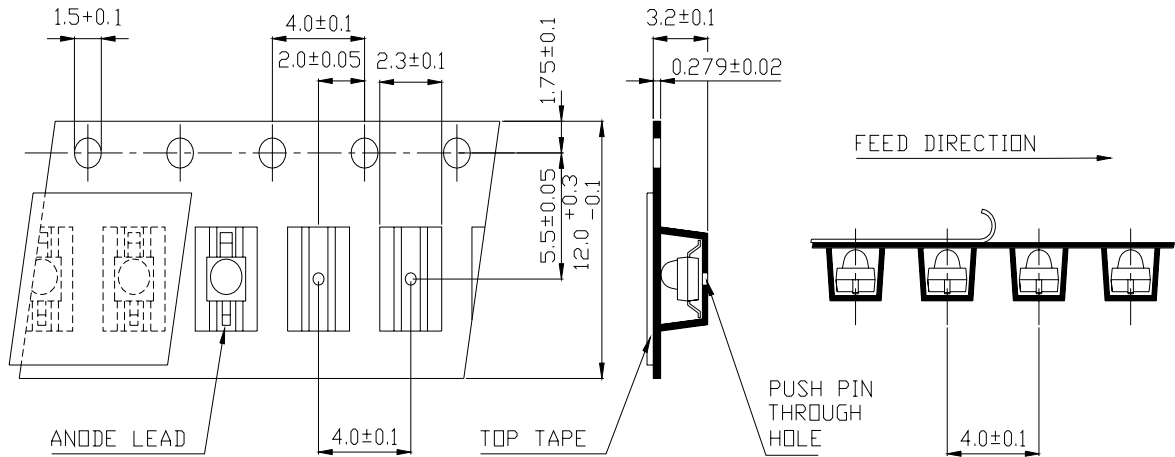

Unit = mm

Moisture Resistant Packaging

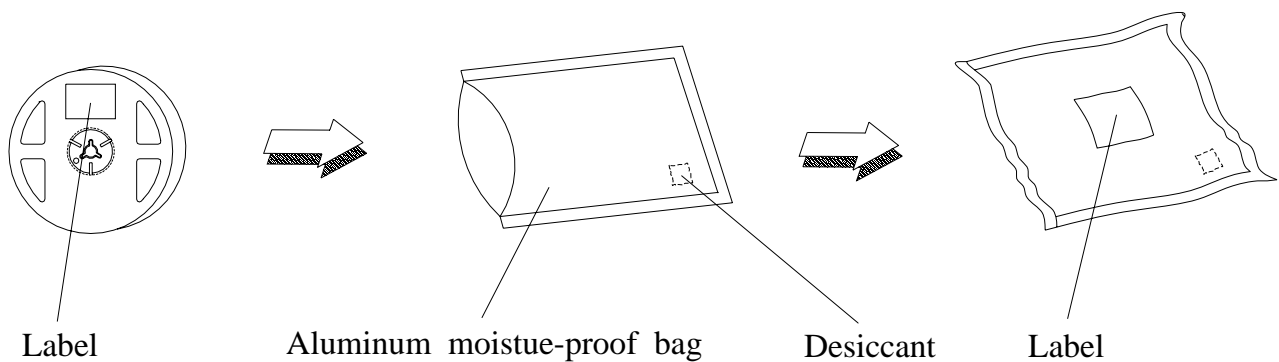

Reliability Test Items And Conditions

The reliability of products shall be satisfied with items listed below.

Confidence level : 90 %

LTPD : 10 %

No.	Items	Test Condition	Test Hours/Cycles	Sample Size	Ac/Re
1	Reflow Soldering	Temp. : 260°C ±5°C Min. 5 sec.	6 Min.	22 Pcs.	0/1
2	Temperature Cycle	H : +100°C 15 min. § 5 min. L : -40°C 15 min.	300 Cycles	22 Pcs.	0/1
3	Thermal Shock	H : +100°C 5 min. § 10 sec. L : -10°C 5 min.	300 Cycles	22 Pcs.	0/1
4	High Temperature Storage	Temp. : 100°C	1000 Hrs.	22 Pcs.	0/1
5	Low Temperature Storage	Temp. : -40°C	1000 Hrs.	22 Pcs.	0/1
6	DC Operating Life	IF = 20 mA	1000 Hrs.	22 Pcs.	0/1
7	High Temperature / High Humidity	85°C / 85% RH	1000 Hrs.	22 Pcs.	0/1

Precautions For Use

1. Over-current-proof

Customer must apply resistors for protection , otherwise slight voltage shift will cause big current change (Burn out will happen).

2. Storage

2.1 Do not open moisture proof bag before the products are ready to use.

2.2 Before opening the package, the LEDs should be kept at 30°C or less and 90%RH or less.

2.3 The LEDs should be used within a year.

2.4 After opening the package, the LEDs should be kept at 30°C or less and 70%RH or less.

2.5 The LEDs should be used within 168 hours (7 days) after opening the package.

2.6 If the moisture absorbent material (silica gel) has faded away or the LEDs have exceeded the storage time, baking treatment should be performed using the following conditions.

Baking treatment : 60±5°C for 24 hours.

3. Soldering Condition

3.1 Pb-free solder temperature profile

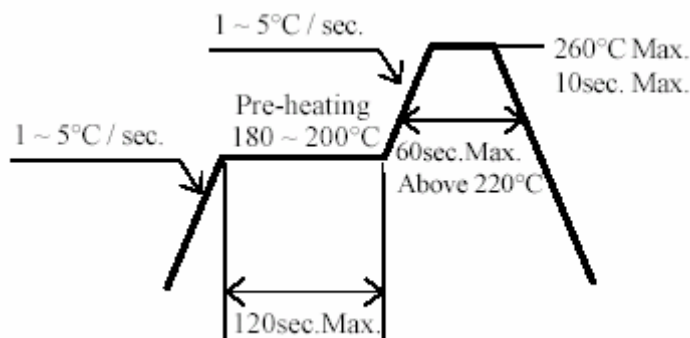

3.2 Reflow soldering should not be done more than two times.

3.3 When soldering, do not put stress on the LEDs during heating.

3.4 After soldering, do not warp the circuit board.

4. Soldering Iron

Each terminal is to go to the tip of soldering iron temperature less than 280°C for 3 seconds within once in less than the soldering iron capacity 25W. Leave two seconds and more intervals, and do soldering of each terminal. Be careful because the damage of the product is often started at the time of the hand solder.

95-21UYOC/S530-XX/TRXX**5.Repairing**

Repair should not be done after the LEDs have been soldered. When repairing is unavoidable, a double-head soldering iron should be used (as below figure). It should be confirmed beforehand whether the characteristics of the LEDs will or will not be damaged by repairing.

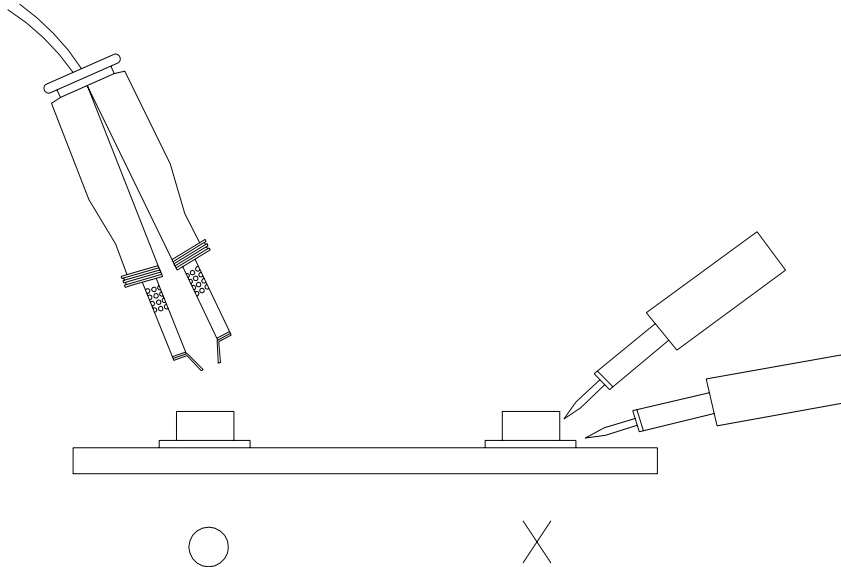

EVERLIGHT ELECTRONICS CO., LTD.
Office: No 25, Lane 76, Sec 3, Chung Yang Rd,
Tucheng, Taipei 236, Taiwan, R.O.C

Tel: 886-2-2267-2000, 2267-9936
Fax: 886-2267-6244, 2267-6189, 2267-6306
<http://www.everlight.com>