

Features

- Very High Speed: 45 ns
- Temperature Ranges
 - Industrial: -40°C to +85°C
 - Automotive-A: -40°C to +85°C
- Wide Voltage Range: 2.20V–3.60V
- Pin Compatible with CY62146DV30
- Ultra Low Standby Power
 - Typical standby current: 1 μ A
 - Maximum standby current: 7 μ A
- Ultra Low Active Power
 - Typical active current: 2 mA at f = 1 MHz
- Easy Memory Expansion with \overline{CE} and \overline{OE} Features
- Automatic Power Down when Deselected
- CMOS for Optimum Speed and Power
- Available in a Pb-free 48-ball VFBGA and 44-pin TSOP II Packages

Functional Description

The CY62146EV30 is a high performance CMOS static RAM organized as 256K words by 16 bits. This device features an advanced circuit design designed to provide an ultra low active

current. Ultra low active current is ideal for providing More Battery Life™ (MoBL[®]) in portable applications such as cellular telephones. The device also has an automatic power down feature that significantly reduces power consumption by 80 percent when addresses are not toggling. The device can also be put into standby mode reducing power consumption by more than 99 percent when deselected (\overline{CE} HIGH). The input and output pins (I/O₀ through I/O₁₅) are placed in a high impedance state when the device is deselected (\overline{CE} HIGH), outputs are disabled (\overline{OE} HIGH), both Byte High Enable and Byte Low Enable are disabled (\overline{BHE} , \overline{BLE} HIGH), or a write operation is in progress (\overline{CE} LOW and \overline{WE} LOW).

To write to the device, take Chip Enable (\overline{CE}) and Write Enable (\overline{WE}) input LOW. If Byte Low Enable (\overline{BLE}) is LOW, then data from I/O pins (I/O₀ through I/O₇) is written into the location specified on the address pins (A₀ through A₁₇). If Byte High Enable (\overline{BHE}) is LOW, then data from the I/O pins (I/O₈ through I/O₁₅) is written into the location specified on the address pins (A₀ through A₁₇).

To read from the device, take Chip Enable (\overline{CE}) and Output Enable (\overline{OE}) LOW while forcing the Write Enable (\overline{WE}) HIGH. If Byte Low Enable (\overline{BLE}) is LOW, then data from the memory location specified by the address pins appears on I/O₀ to I/O₇. If Byte High Enable (\overline{BHE}) is LOW, then data from memory appears on I/O₈ to I/O₁₅. See the "Truth Table" on page 9 for a complete description of read and write modes.

For best practice recommendations, refer to the Cypress application note [AN1064, SRAM System Guidelines](#).

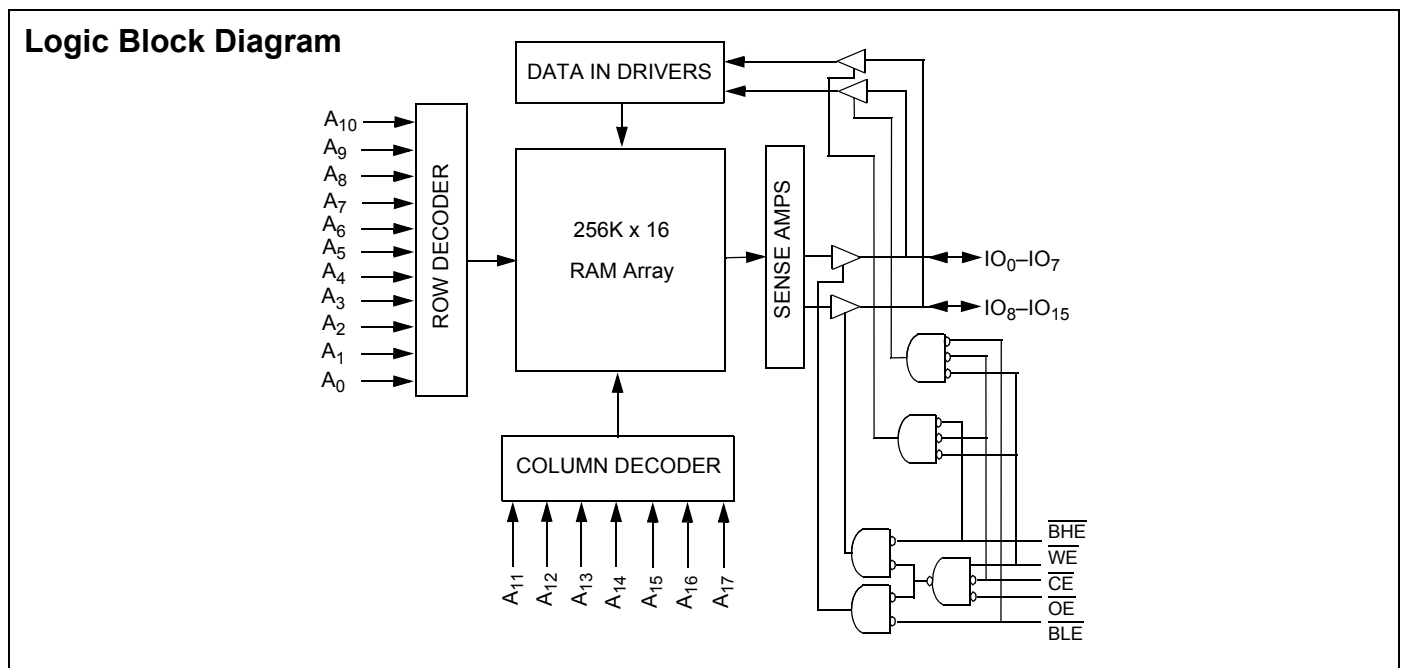

Pin Configuration

Figure 1. 48-Ball VFBGA Pinout [1, 2]

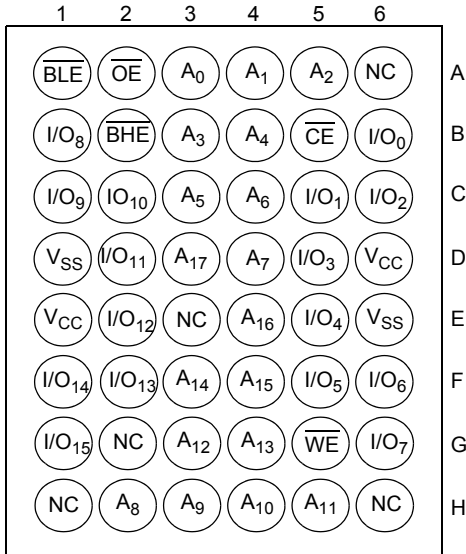
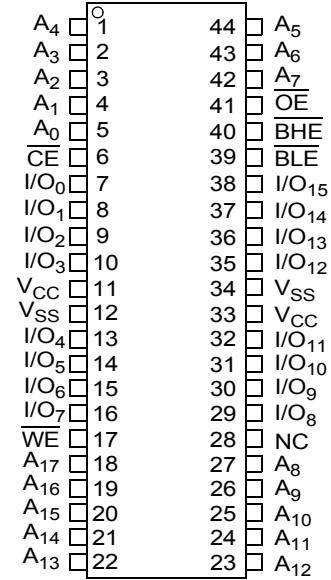

Figure 2. 44-Pin TSOP II [1]



Product Portfolio

Product	Range	V _{CC} Range (V)			Speed (ns)	Power Dissipation					
						Operating I _{CC} (mA)				Standby I _{SB2} (μA)	
						f = 1 MHz		f = f _{max}			
		Min	Typ ^[3]	Max		Typ ^[3]	Max	Typ ^[3]	Max	Typ ^[3]	Max
CY62146EV30LL	Ind/I/Auto-A	2.2	3.0	3.6	45 ns	2	2.5	15	20	1	7

Notes

1. NC pins are not connected on the die.
2. Pins H1, G2, and H6 in the BGA package are address expansion pins for 8 Mb, 16 Mb and 32 Mb, respectively.
3. Typical values are included for reference only and are not guaranteed or tested. Typical values are measured at V_{CC} = V_{CC(typ)}, T_A = 25°C.

Maximum Ratings

Exceeding the maximum ratings may impair the useful life of the device. These user guidelines are not tested.

Storage Temperature -65°C to + 150°C
 Ambient Temperature with
 Power Applied -55°C to + 125°C
 Supply Voltage to Ground
 Potential -0.3V to + 3.9V ($V_{CCmax} + 0.3V$)
 DC Voltage Applied to Outputs
 in High-Z State ^[4, 5] -0.3V to 3.9V ($V_{CCmax} + 0.3V$)

DC Input Voltage ^[4, 5] -0.3V to 3.9V ($V_{CCmax} + 0.3V$)
 Output Current into Outputs (LOW) 20 mA
 Static Discharge Voltage >2001V
 (per MIL-STD-883, Method 3015)
 Latch-up Current.....>200 mA

Operating Range

Device	Range	Ambient Temperature	V_{CC} ^[6]
CY62146EV30	Industrial/ Auto-A	-40°C to +85°C	2.2V to 3.6V

Electrical Characteristics

Over the Operating Range

Parameter	Description	Test Conditions	45 ns (Ind'I/Auto-A)			Unit
			Min	Typ ^[3]	Max	
V_{OH}	Output HIGH Voltage	$I_{OH} = -0.1$ mA	2.0			V
		$I_{OH} = -1.0$ mA, $V_{CC} \geq 2.70V$	2.4			V
V_{OL}	Output LOW Voltage	$I_{OL} = 0.1$ mA			0.4	V
		$I_{OL} = 2.1$ mA, $V_{CC} \geq 2.70V$			0.4	V
V_{IH}	Input HIGH Voltage	$V_{CC} = 2.2V$ to 2.7V	1.8		$V_{CC} + 0.3$	V
		$V_{CC} = 2.7V$ to 3.6V	2.2		$V_{CC} + 0.3$	V
V_{IL}	Input LOW Voltage	$V_{CC} = 2.2V$ to 2.7V	-0.3		0.6	V
		$V_{CC} = 2.7V$ to 3.6V	-0.3		0.8	V
I_{IX}	Input Leakage Current	$GND \leq V_I \leq V_{CC}$	-1		+1	μA
I_{OZ}	Output Leakage Current	$GND \leq V_O \leq V_{CC}$, Output Disabled	-1		+1	μA
I_{CC}	V_{CC} Operating Supply Current	$f = f_{max} = 1/t_{RC}$		15	20	mA
		$f = 1$ MHz	$V_{CC} = V_{CC(max)}$, $I_{OUT} = 0$ mA CMOS levels	2	2.5	
I_{SB1}	Automatic CE Power down Current — CMOS Inputs	$\overline{CE} \geq V_{CC} - 0.2V$, $V_{IN} \geq V_{CC} - 0.2V$ or $V_{IN} \leq 0.2V$ $f = f_{max}$ (Address and Data Only), $f = 0$ (OE, BHE, BLE and WE), $V_{CC} = 3.60V$		1	7	μA
I_{SB2} ^[7]	Automatic CE Power down Current — CMOS Inputs	$\overline{CE} \geq V_{CC} - 0.2V$, $V_{IN} \geq V_{CC} - 0.2V$ or $V_{IN} \leq 0.2V$, $f = 0$, $V_{CC} = 3.60V$		1	7	μA

Capacitance

Tested initially and after any design or process changes that may affect these parameters.

Parameter	Description	Test Conditions	Max	Unit
C_{IN}	Input Capacitance	$T_A = 25^\circ C$, $f = 1$ MHz, $V_{CC} = V_{CC(typ)}$	10	pF
C_{OUT}	Output Capacitance		10	pF

Notes

- $V_{IL(min)}$ = -2.0V for pulse durations less than 20 ns.
- $V_{IH(max)}$ = $V_{CC} + 0.75V$ for pulse durations less than 20 ns.
- Full device AC operation assumes a minimum of 100 μs ramp time from 0 to $V_{CC(min)}$ and 200 μs wait time after V_{CC} stabilization.
- Only chip enable (CE) and byte enables (BHE and BLE) need to be tied to CMOS levels to meet the I_{SB2} / I_{CCDR} spec. Other inputs can be left floating.

Thermal Resistance

Tested initially and after any design or process changes that may affect these parameters.

Parameter	Description	Test Conditions	VFBGA	TSOP II	Unit
Θ_{JA}	Thermal Resistance (Junction to Ambient)	Still Air, soldered on a 3 × 4.5 inch, two-layer printed circuit board	75	77	°C/W
Θ_{JC}	Thermal Resistance (Junction to Case)		10	13	°C/W

Figure 3. AC Test Loads and Waveforms

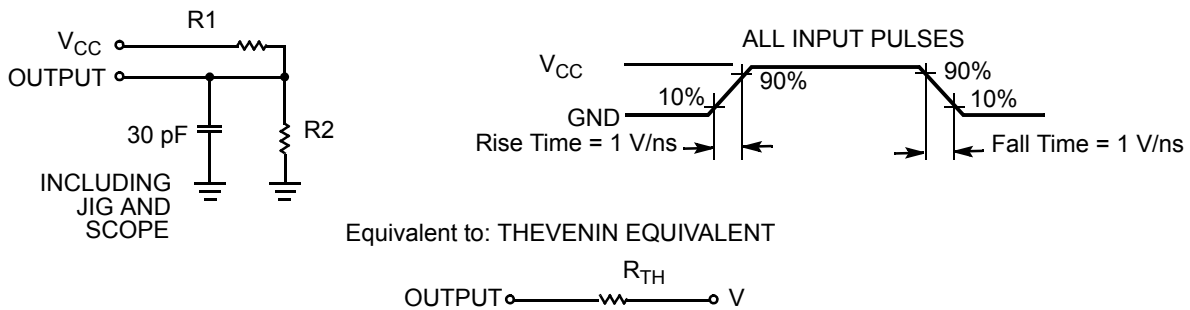

Parameters	2.50V	3.0V	Unit
R1	16667	1103	Ω
R2	15385	1554	Ω
R _{TH}	8000	645	Ω
V _{TH}	1.20	1.75	V

Data Retention Characteristics

Over the Operating Range

Parameter	Description	Conditions	Min	Typ ^[3]	Max	Unit
V _{DR}	V _{CC} for Data Retention		1.5			V
I _{CCDR} ^[7]	Data Retention Current	V _{CC} = 1.5V, $\overline{CE} \geq V_{CC} - 0.2V$, V _{IN} ≥ V _{CC} - 0.2V or V _{IN} ≤ 0.2V		0.8	7	μA
t _{CDR} ^[8]	Chip Deselect to Data Retention Time		0			ns
t _R ^[9]	Operation Recovery Time		t _{RC}			ns

Figure 4. Data Retention Waveform

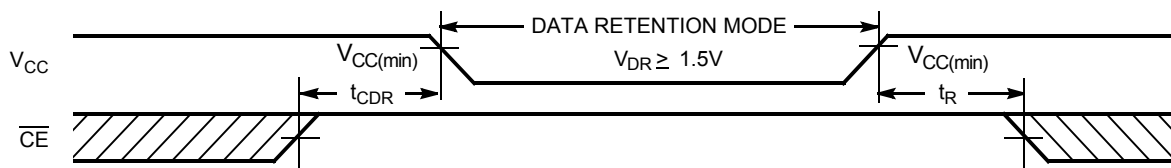

Notes

- Tested initially and after any design or process changes that may affect these parameters.
- Full device operation requires linear V_{CC} ramp from V_{DR} to V_{CC(min)} ≥ 100 μs or stable at V_{CC(min)} ≥ 100 μs .

Switching Characteristics

Over the Operating Range ^[10, 11]

Parameter	Description	45 ns (Industrial/Auto-A)		Unit
		Min	Max	
Read Cycle				
t_{RC}	Read Cycle Time	45		ns
t_{AA}	Address to Data Valid		45	ns
t_{OHA}	Data Hold from Address Change	10		ns
t_{ACE}	\overline{CE} LOW to Data Valid		45	ns
t_{DOE}	\overline{OE} LOW to Data Valid		22	ns
t_{LZOE}	\overline{OE} LOW to Low-Z ^[12]	5		ns
t_{HZOE}	\overline{OE} HIGH to High-Z ^[12, 13]		18	ns
t_{LZCE}	\overline{CE} LOW to Low-Z ^[12]	10		ns
t_{HZCE}	\overline{CE} HIGH to High-Z ^[12, 13]		18	ns
t_{PU}	\overline{CE} LOW to Power Up	0		ns
t_{PD}	\overline{CE} HIGH to Power Down		45	ns
t_{DBE}	\overline{BLE} / \overline{BHE} LOW to Data Valid		22	ns
t_{LZBE}	\overline{BLE} / \overline{BHE} LOW to Low-Z ^[12]	5		ns
t_{HZBE}	\overline{BLE} / \overline{BHE} HIGH to High-Z ^[12, 13]		18	ns
Write Cycle ^[14]				
t_{WC}	Write Cycle Time	45		ns
t_{SCE}	\overline{CE} LOW to Write End	35		ns
t_{AW}	Address Setup to Write End	35		ns
t_{HA}	Address Hold from Write End	0		ns
t_{SA}	Address Setup to Write Start	0		ns
t_{PWE}	\overline{WE} Pulse Width	35		ns
t_{BW}	\overline{BLE} / \overline{BHE} LOW to Write End	35		ns
t_{SD}	Data Setup to Write End	25		ns
t_{HD}	Data Hold from Write End	0		ns
t_{HZWE}	\overline{WE} LOW to High-Z ^[12, 13]		18	ns
t_{LZWE}	\overline{WE} HIGH to Low-Z ^[12]	10		ns

Notes

10. Test conditions for all parameters other than tri-state parameters assume signal transition time of 3 ns (1V/ns) or less, timing reference levels of $V_{CC(typ)}/2$, input pulse levels of 0 to $V_{CC(typ)}$, and output loading of the specified I_{OL}/I_{OH} as shown in the "AC Test Loads and Waveforms" on page 4.
11. AC timing parameters are subject to byte enable signals (BHE or BLE) not switching when chip is disabled. Please see application note AN13842 for further clarification.
12. At any given temperature and voltage condition, t_{HZCE} is less than t_{LZCE} , t_{HZBE} is less than t_{LZBE} , t_{HZOE} is less than t_{LZOE} , and t_{HZWE} is less than t_{LZWE} for any given device.
13. t_{HZOE} , t_{HZCE} , t_{HZBE} , and t_{HZWE} transitions are measured when the outputs enter a high impedance state.
14. The internal write time of the memory is defined by the overlap of \overline{WE} , $CE = V_{IL}$, \overline{BHE} and/or $\overline{BLE} = V_{IL}$. All signals must be ACTIVE to initiate a write and any of these signals can terminate a write by going INACTIVE. The data input setup and hold timing must be referenced to the edge of the signal that terminates the write.

Switching Waveforms

Figure 5. Read Cycle 1 (Address Transition Controlled) [15, 16]

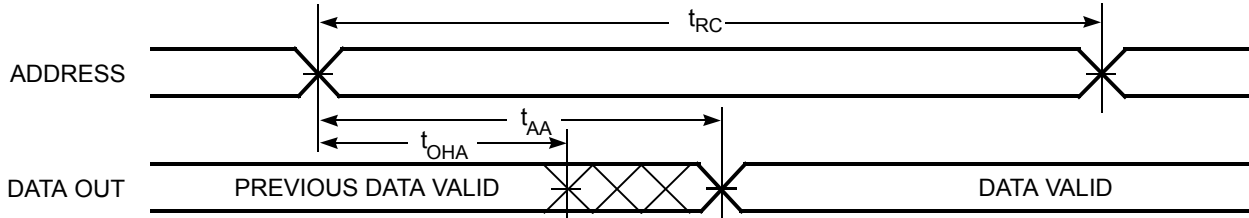
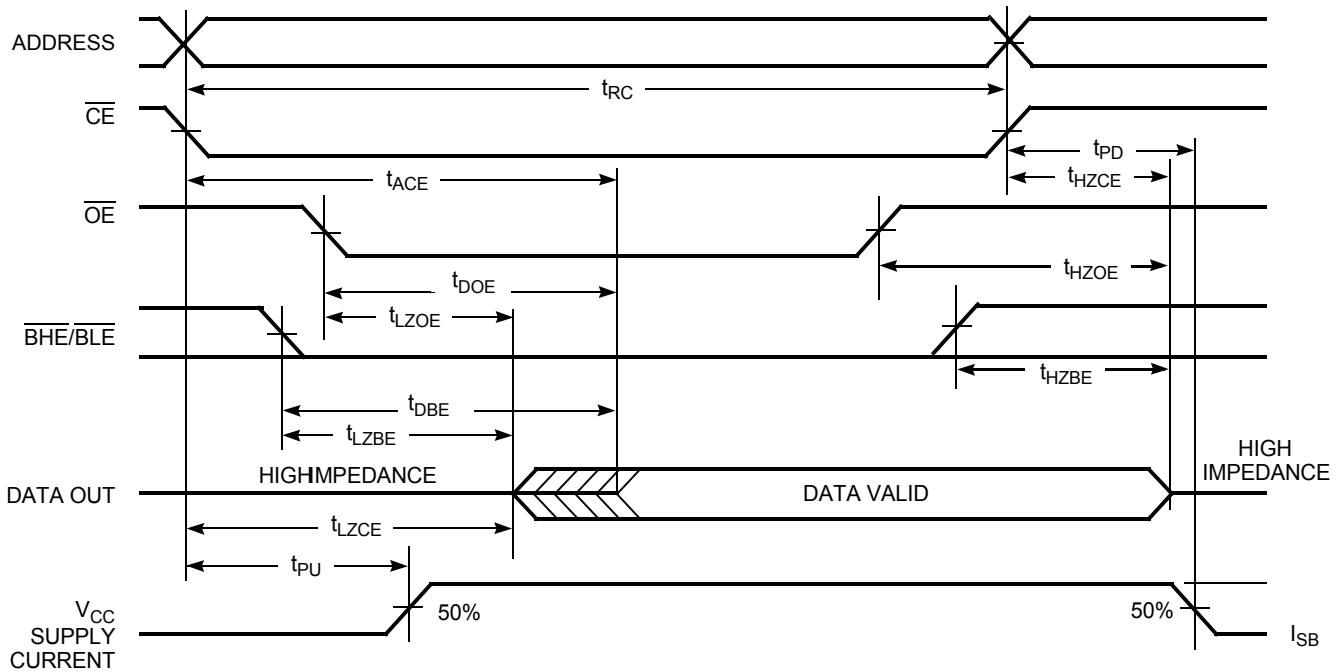

Figure 6. Read Cycle No. 2 (\overline{OE} Controlled) [16, 17]



Notes

- 15. The device is continuously selected. \overline{OE} , \overline{CE} = V_{IL} , \overline{BHE} and/or \overline{BLE} = V_{IL} .
- 16. \overline{WE} is HIGH for read cycle.
- 17. Address valid before or similar to \overline{CE} and \overline{BHE} , \overline{BLE} transition LOW.

Switching Waveforms (continued)

Figure 7. Write Cycle No. 1 (\overline{WE} Controlled) [14, 18, 19]

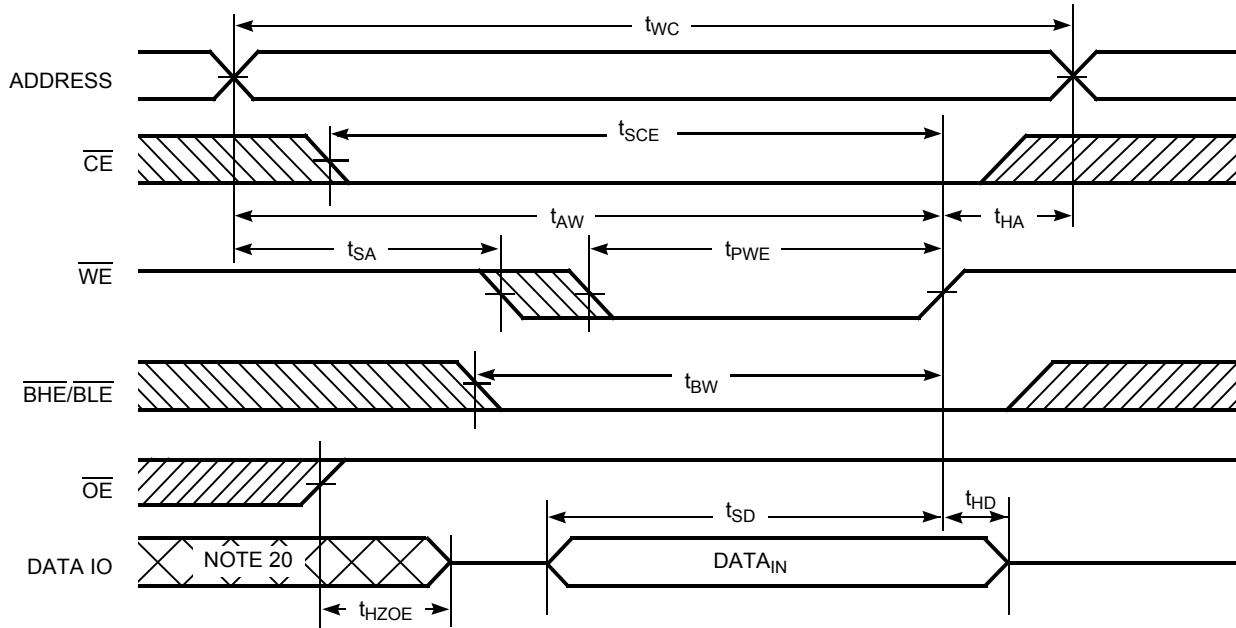
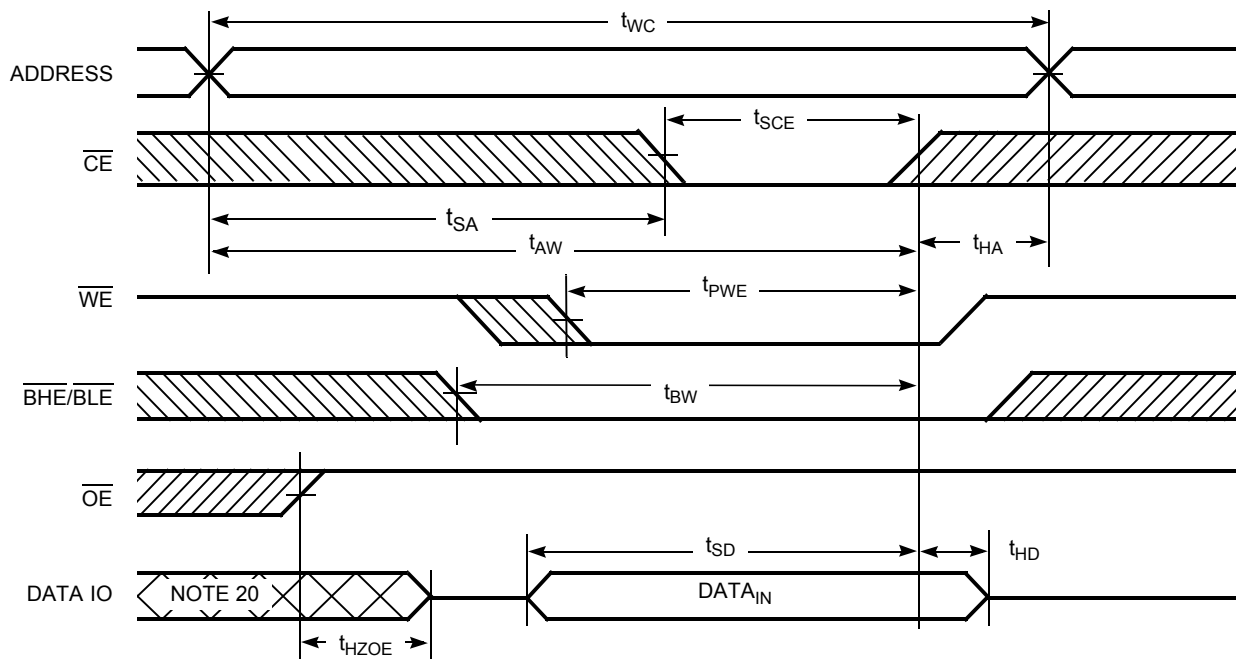

Figure 8. Write Cycle No. 2 (\overline{CE} Controlled) [14, 18, 19]



Notes:

- 18. Data IO is high impedance if $\overline{OE} = V_{IH}$.
- 19. If \overline{CE} goes HIGH simultaneously with $\overline{WE} = V_{IH}$, the output remains in a high impedance state.
- 20. During this period, the IOs are in output state and input signals must not be applied.

Switching Waveforms (continued)

Figure 9. Write Cycle No. 3 (\overline{WE} Controlled, \overline{OE} LOW) [19]

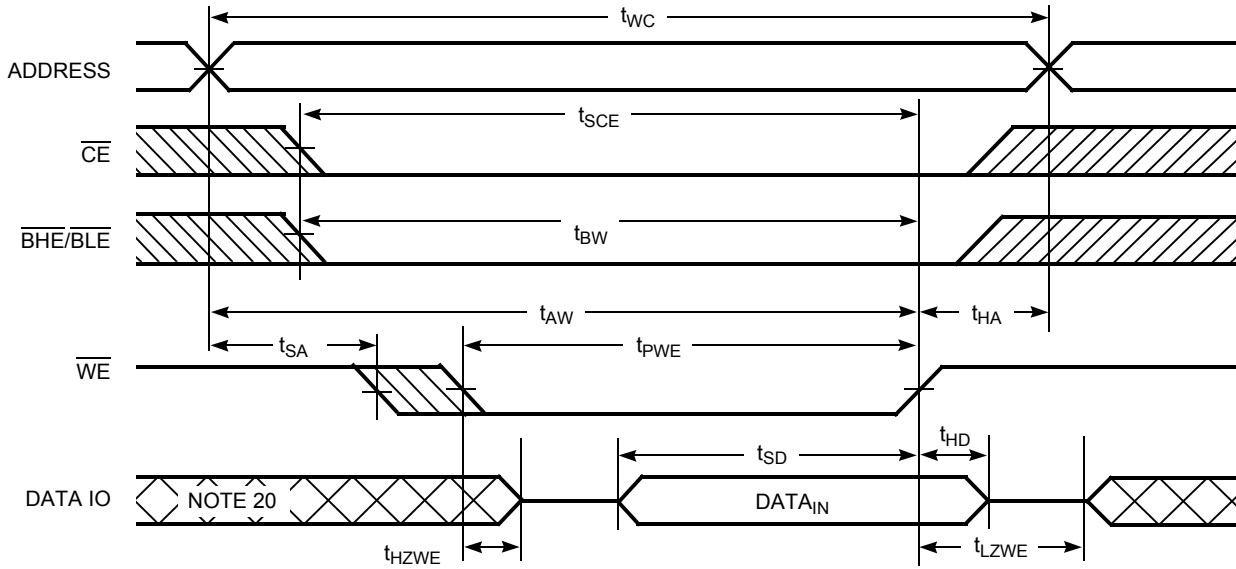
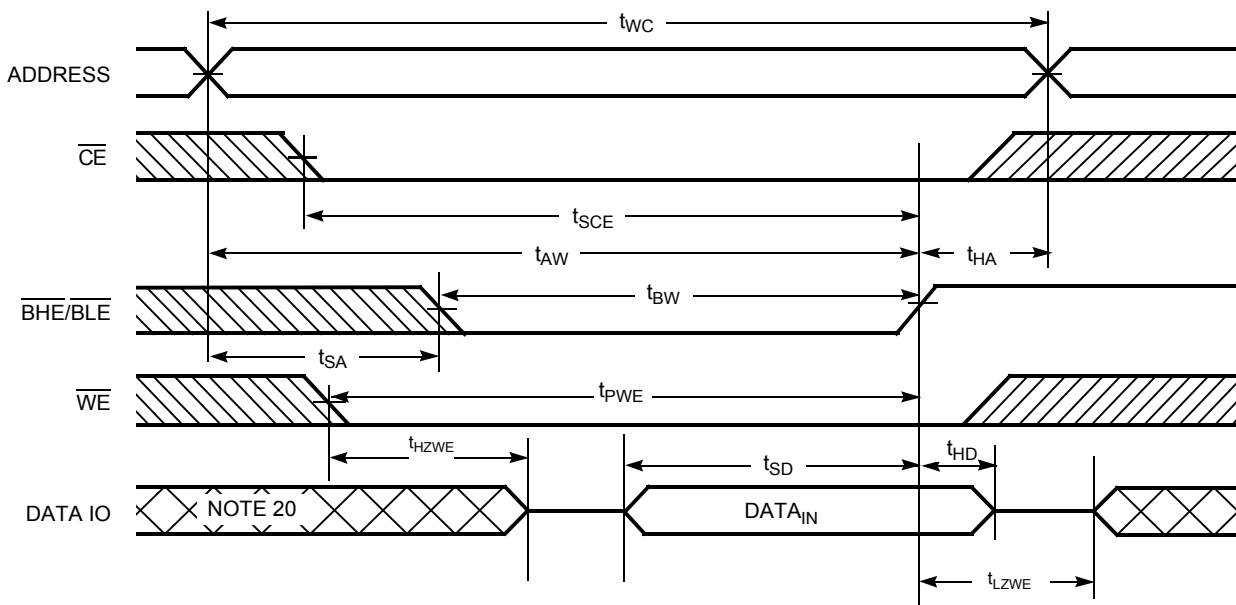

Figure 10. Write Cycle No. 4 ($\overline{BHE/BLE}$ Controlled, \overline{OE} LOW) [19]



Truth Table

\overline{CE}	\overline{WE}	\overline{OE}	\overline{BHE}	\overline{BLE}	Inputs/Outputs	Mode	Power
H	X	X	X	X	High-Z	Deselect/Power down	Standby (I_{SB})
L	X	X	H	H	High-Z	Output Disabled	Active (I_{CC})
L	H	L	L	L	Data Out (I/O_0 – I/O_{15})	Read	Active (I_{CC})
L	H	L	H	L	Data Out (I/O_0 – I/O_7); I/O_8 – I/O_{15} in High-Z	Read	Active (I_{CC})
L	H	L	L	H	Data Out (I/O_8 – I/O_{15}); I/O_0 – I/O_7 in High-Z	Read	Active (I_{CC})
L	H	H	L	L	High-Z	Output Disabled	Active (I_{CC})
L	H	H	H	L	High-Z	Output Disabled	Active (I_{CC})
L	H	H	L	H	High-Z	Output Disabled	Active (I_{CC})
L	L	X	L	L	Data In (I/O_0 – I/O_{15})	Write	Active (I_{CC})
L	L	X	H	L	Data In (I/O_0 – I/O_7); I/O_8 – I/O_{15} in High-Z	Write	Active (I_{CC})
L	L	X	L	H	Data In (I/O_8 – I/O_{15}); I/O_0 – I/O_7 in High-Z	Write	Active (I_{CC})

Ordering Information

Speed (ns)	Ordering Code	Package Diagram	Package Type	Operating Range
45	CY62146EV30LL-45BVXI	51-85150	48-Ball VFBGA (Pb-free)	Industrial
	CY62146EV30LL-45ZSXI	51-85087	44-Pin TSOP II (Pb-free)	
	CY62146EV30LL-45ZSXA	51-85087	44-Pin TSOP II (Pb-free)	Automotive-A

Please contact your local Cypress sales representative for availability of other parts

Package Diagrams

Figure 11. 48-ball VFBGA (6 x 8 x 1 mm), 51-85150

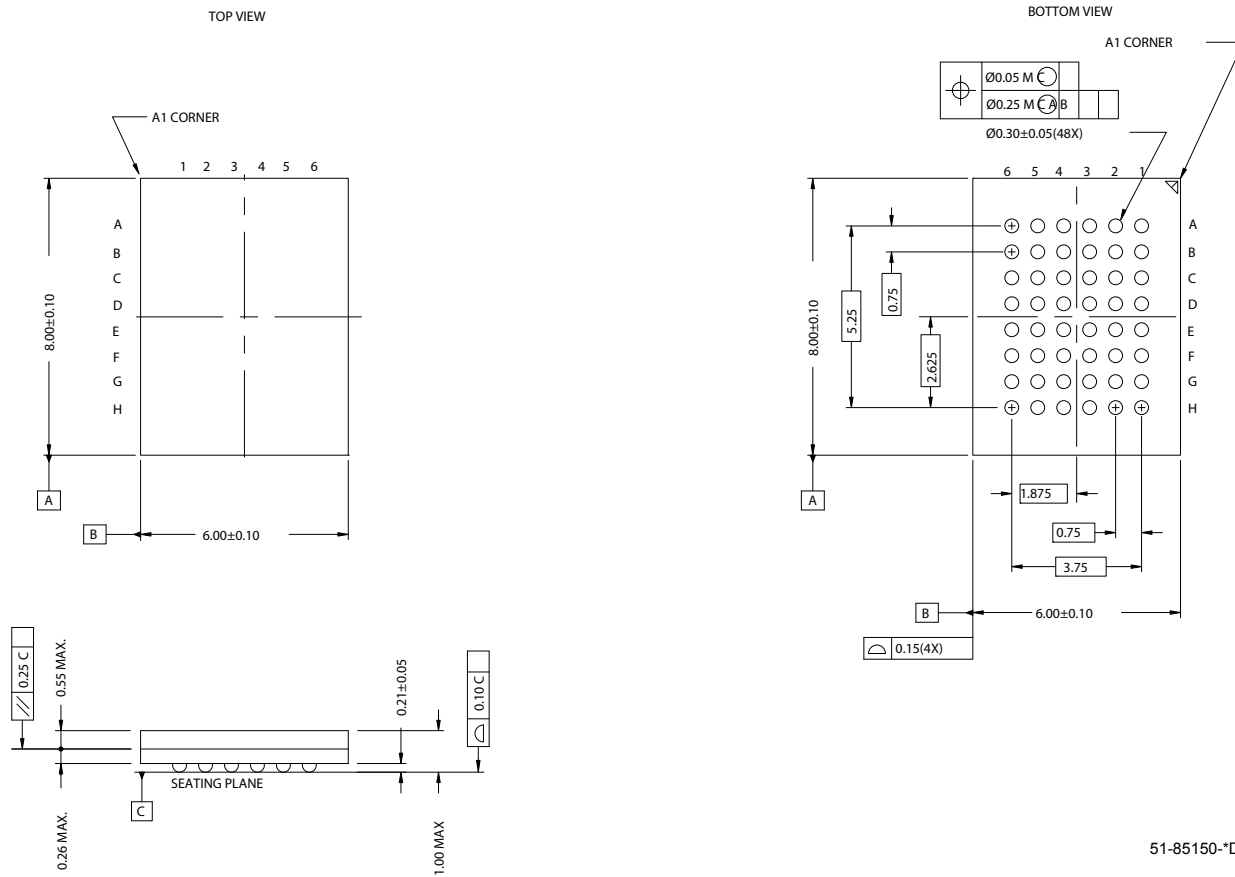

51-85150-*D

Package Diagrams (continued)

Figure 12. 44-pin TSOP II, 51-85087

DIMENSION IN MM (INCH)
MAX
MIN

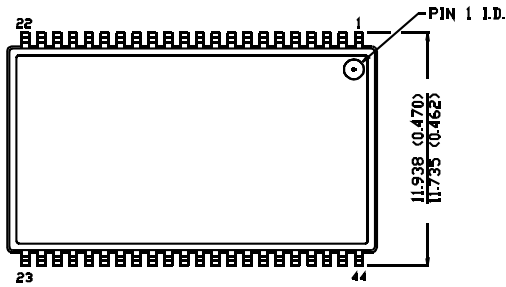

TOP VIEW

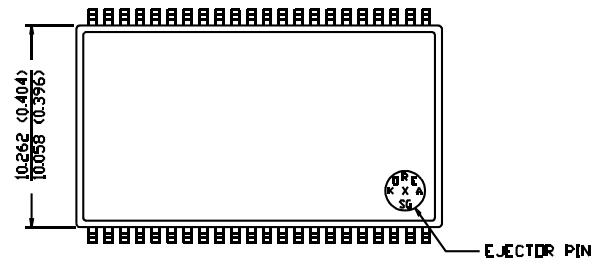

BOTTOM VIEW

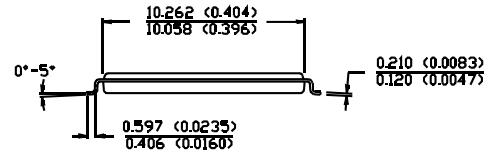
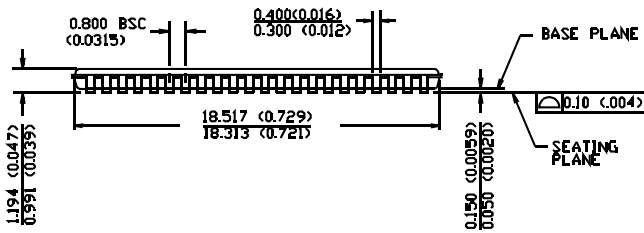

51-85087-*A

Document History Page

Document Title: CY62146EV30 MoBL®, 4-Mbit (256K x 16) Static RAM				
Document Number: 38-05567				
REV.	ECN NO.	Orig. of Change	Submission Date	Description of Change
**	223225	AJU	See ECN	New Data Sheet
*A	247373	SYT	See ECN	<p>Changed Advance Information to Preliminary</p> <p>Moved Product Portfolio to Page 2</p> <p>Changed V_{CC} stabilization time in footnote #8 from 100 μs to 200 μs</p> <p>Removed Footnote #14(t_{LZBE}) from Previous revision</p> <p>Changed I_{CCDR} from 2.0 μA to 2.5 μA</p> <p>Changed typ_o in Data Retention Characteristics(t_R) from 100 μs to t_{RC} ns</p> <p>Changed t_{OHA} from 6 ns to 10 ns for both 35 ns and 45 ns Speed Bin</p> <p>Changed t_{HZOE}, t_{HZBE}, t_{HZWE} from 12 to 15 ns for 35 ns Speed Bin and 15 to 18 ns for 45 ns Speed Bin</p> <p>Changed t_{SCE} and t_{BW} from 25 to 30 ns for 35 ns Speed Bin and 40 to 35 ns for 45 ns Speed Bin</p> <p>Changed t_{HZCE} from 12 to 18 ns for 35 ns Speed Bin and 15 to 22 ns for 45 ns Speed Bin</p> <p>Changed t_{SD} from 15 to 18 ns for 35 ns Speed Bin and 20 to 22 ns for 45 ns Speed Bin</p> <p>Changed t_{DOE} from 15 to 18 ns for 35 ns Speed Bin</p> <p>Changed t_{DBE} from 15 to 18 ns for 35 ns Speed Bin</p> <p>Changed Ordering Information to include Pb-Free Packages</p>
*B	414807	ZSD	See ECN	<p>Changed from Preliminary information to Final</p> <p>Changed the address of Cypress Semiconductor Corporation on Page #1 from "3901 North First Street" to "198 Champion Court"</p> <p>Removed 35ns Speed Bin</p> <p>Removed "L" version of CY62146EV30</p> <p>Changed ball E3 from DNU to NC</p> <p>Removed the redundant foot note on DNU.</p> <p>Changed I_{CC} (Max) value from 2 mA to 2.5 mA and I_{CC} (Typ) value from 1.5 mA to 2 mA at f=1 MHz</p> <p>Changed I_{CC} (Typ) value from 12 mA to 15 mA at f = f_{max}</p> <p>Changed I_{SB1} and I_{SB2} Typ values from 0.7 μA to 1 μA and Max values from 2.5 μA to 7 μA.</p> <p>Changed the AC test load capacitance from 50pF to 30pF on Page# 4</p> <p>Changed I_{CCDR} from 2.5 μA to 7 μA.</p> <p>Added I_{CCDR} typical value.</p> <p>Changed t_{LZOE} from 3 ns to 5 ns</p> <p>Changed t_{LZCE} and t_{LZWE} from 6 ns to 10 ns</p> <p>Changed t_{LZBE} from 6 ns to 5 ns</p> <p>Changed t_{HZCE} from 22 ns to 18 ns</p> <p>Changed t_{PWE} from 30 ns to 35 ns.</p> <p>Changed t_{SD} from 22 ns to 25 ns.</p> <p>Updated the package diagram 48-ball VFBGA from *B to *D</p> <p>Updated the ordering information table and replaced the Package Name column with Package Diagram.</p>
*C	925501	VKN	See ECN	<p>Added footnote #8 related to I_{SB2} and I_{CCDR}</p> <p>Added footnote #12 related AC timing parameters</p>
*D	2678796	VKN/PYRS	03/25/2009	Added Automotive-A information

Sales, Solutions, and Legal Information

Worldwide Sales and Design Support

Cypress maintains a worldwide network of offices, solution centers, manufacturer's representatives, and distributors. To find the office closest to you, visit us at cypress.com/sales.

Products

PSoC	psoc.cypress.com
Clocks & Buffers	clocks.cypress.com
Wireless	wireless.cypress.com
Memories	memory.cypress.com
Image Sensors	image.cypress.com

PSoC Solutions

General	psoc.cypress.com/solutions
Low Power/Low Voltage	psoc.cypress.com/low-power
Precision Analog	psoc.cypress.com/precision-analog
LCD Drive	psoc.cypress.com/lcd-drive
CAN 2.0b	psoc.cypress.com/can
USB	psoc.cypress.com/usb

© Cypress Semiconductor Corporation, 2004-2009. The information contained herein is subject to change without notice. Cypress Semiconductor Corporation assumes no responsibility for the use of any circuitry other than circuitry embodied in a Cypress product. Nor does it convey or imply any license under patent or other rights. Cypress products are not warranted nor intended to be used for medical, life support, life saving, critical control or safety applications, unless pursuant to an express written agreement with Cypress. Furthermore, Cypress does not authorize its products for use as critical components in life-support systems where a malfunction or failure may reasonably be expected to result in significant injury to the user. The inclusion of Cypress products in life-support systems application implies that the manufacturer assumes all risk of such use and in doing so indemnifies Cypress against all charges.

Any Source Code (software and/or firmware) is owned by Cypress Semiconductor Corporation (Cypress) and is protected by and subject to worldwide patent protection (United States and foreign), United States copyright laws and international treaty provisions. Cypress hereby grants to licensee a personal, non-exclusive, non-transferable license to copy, use, modify, create derivative works of, and compile the Cypress Source Code and derivative works for the sole purpose of creating custom software and or firmware in support of licensee product to be used only in conjunction with a Cypress integrated circuit as specified in the applicable agreement. Any reproduction, modification, translation, compilation, or representation of this Source Code except as specified above is prohibited without the express written permission of Cypress.

Disclaimer: CYPRESS MAKES NO WARRANTY OF ANY KIND, EXPRESS OR IMPLIED, WITH REGARD TO THIS MATERIAL, INCLUDING, BUT NOT LIMITED TO, THE IMPLIED WARRANTIES OF MERCHANTABILITY AND FITNESS FOR A PARTICULAR PURPOSE. Cypress reserves the right to make changes without further notice to the materials described herein. Cypress does not assume any liability arising out of the application or use of any product or circuit described herein. Cypress does not authorize its products for use as critical components in life-support systems where a malfunction or failure may reasonably be expected to result in significant injury to the user. The inclusion of Cypress' product in a life-support systems application implies that the manufacturer assumes all risk of such use and in doing so indemnifies Cypress against all charges.

Use may be limited by and subject to the applicable Cypress software license agreement.