

SiC714CD10 MOSFET Plus Driver Evaluation Board

FEATURES

- MOSFET Plus Driver PowerPAK® MLF 10 x 10 Product Demonstration
- 10 V to 14 V Input Voltage
- Switching Frequency: 100 kHz to > 1 MHz
- Up to 27 A Output Current

DESCRIPTION

The SiDB766707 evaluation board provides a reference design for evaluating the performance of the SiC714CD10. The module contains all of the circuitry necessary to control a synchronous buck converter in voltage mode configuration. This document explains how to construct basic power conversion circuits using the SiC714CD10 and includes test results.

The evaluation board includes a voltage mode controller (TL5001), power up/down sequence circuitry, and a linear regulator (7805) which generates a 5 V output from a 12 V input for control voltage supply. The board is fully assembled and tested and ready for immediate use.

Included in this document are the Bill-Of-Material, Schematics, PCB Layout, and test results.

OPERATING SPECIFICATIONS

Table 1 summarizes the performance specifications of the SiDB766707.

TABLE 1				
Operating Specifications (as shipped)				
Specification	Min	Typ	Max	Units
Input Voltage Range (V_{IN})	10	12	14	V
Output Voltage (V_{OUT})				
SiDB766707-B		3.3		V
SiDB766707-C		2.5		V
SiDB766707-D		1.3		V
Output Current (I_{OUT}) (12 V_{IN} /2.5 V_{OUT} , F_{SW} = 300 kHz)		27		A
Efficiency (12 V_{IN} /2.5 V_{OUT} , I_{OUT} = 7 A)		94.5		%
Operating Frequency		300		kHz

ORDERING INFORMATION

EVB Order Number	V_{IN}	V_{OUT}
SiDB766707-B	12 V	3.3 V
SiDB766707-C	12 V	2.5 V
SiDB766707-D	12 V	1.3 V

The evaluation board layout is available in Gerber file format. Please contact your Vishay sales representative or distributor for a copy.

TEST SET UP

Figure 1 shows the input-output connections to the SiDB766707.

Note: Before making any EVB set up changes it is strongly advised to power down and disconnect power supplies.

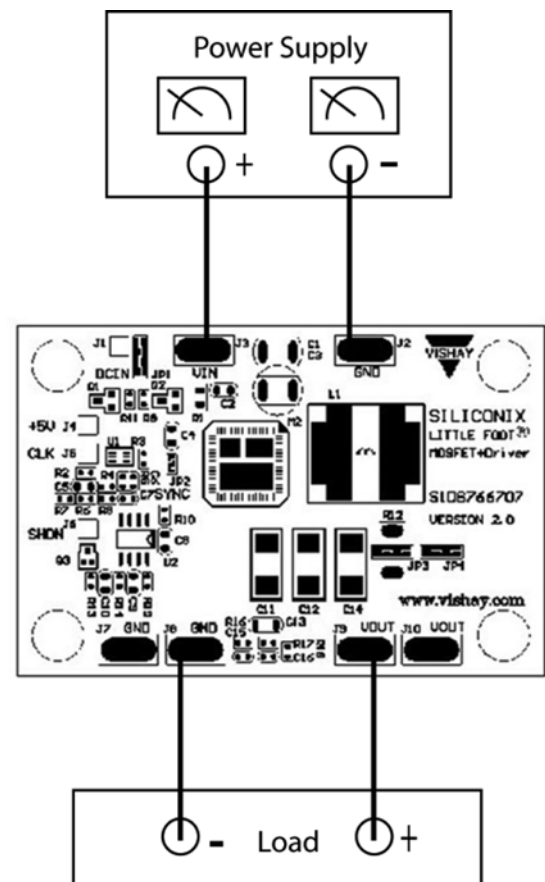

Figure 1. Test Set Up

SWITCHING FREQUENCY ADJUSTMENT

The switching frequency can be selected by changing the resistance of R15. Table 2 shows typical switching frequency relative to the R15 value. The SiDB766707 EVB comes preset with an R15 of 22.6 kΩ for 300 kHz operation.

TABLE 2	
Frequency vs. R15	
Frequency	R15
300 kHz	22.6 kΩ
400 kHz	15 kΩ

OUTPUT VOLTAGE PROGRAMMING

The output voltage can be programmed by selecting four components as shown in Table 3.

TABLE 3				
V _{OUT}	R17	R5	C6	C7
3.3 V	7.68 kΩ	10 kΩ	5.6 nF	220 pF
2.5 V	4.99 kΩ	7.68 kΩ	6.8 nF	220 pF
1.3 V	1 kΩ	3.4 kΩ	15 nF	1800 pF

ELECTRICAL PERFORMANCE

The SiDB766707 evaluation board provides optimum efficiency. Typical performance is shown in Figure 2 to Figure 4. Note that the efficiency was obtained after U1, U2 and U3 (see schematic) were disabled. For the

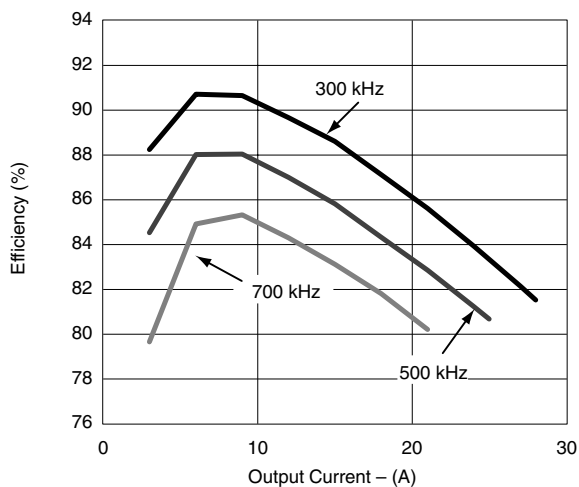

Figure 2. Total Efficiency 12 V_{IN}/1.3 V_{OUT}

JUMPER PIN DESCRIPTION

TABLE 4		
	Description	Default
JP1	Selection of LDO (7805) input voltage: (1) short; LDO input voltage = V _{IN} (2) open; The LDO input voltage must be supplied from DCIN (J1) externally.	Short
JP2	SYNC Selection: (1) short to V _{DD} = normal PWM (2) short to GND = SYNC enabled, i.e. the low-side MOSFET is disabled and is held in the of state	Short to V _{DD}
JP3 JP4	Selection of a shunt resistor (R12)	Short

efficiency measurements, an external function generator was used to generate PWM signals for open-loop operation.

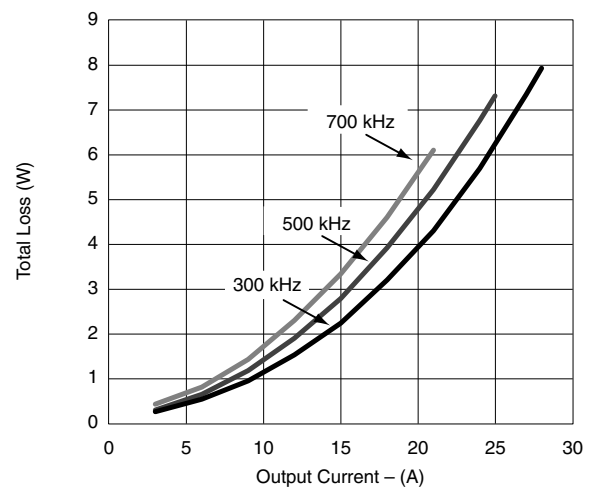

Figure 3. Total Loss 12 V_{IN}/2.5 V_{OUT}

ELECTRICAL PERFORMANCE

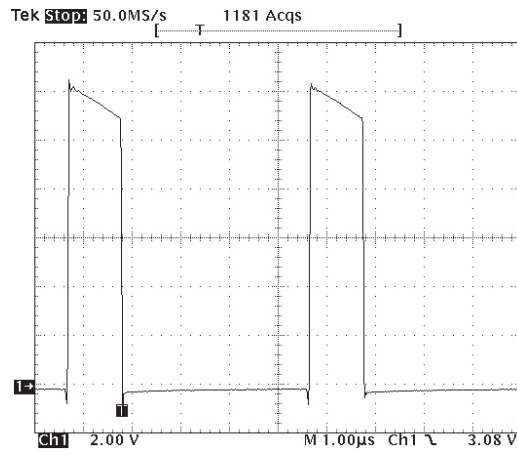

Figure 4. Measured Switch Voltage V_{SW} ($V_{IN} = 12\text{ V}$, $V_{OUT} = 2.5\text{ V}$, $I_{OUT} = 20\text{ A}$)

LAYOUT

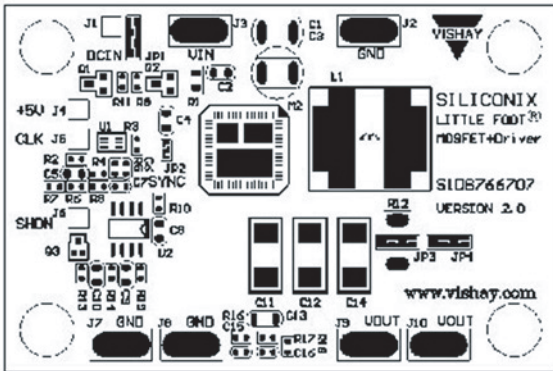

Figure 5. Top Silk Screen

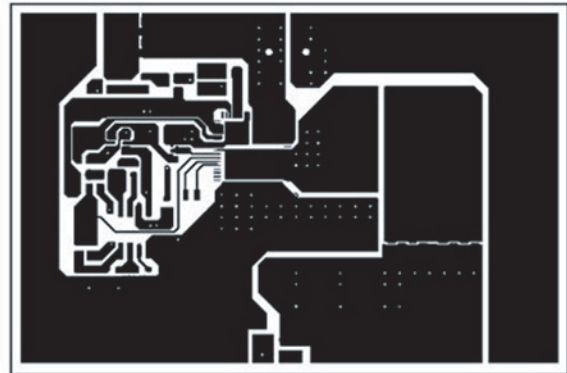

Figure 6. Top Layer

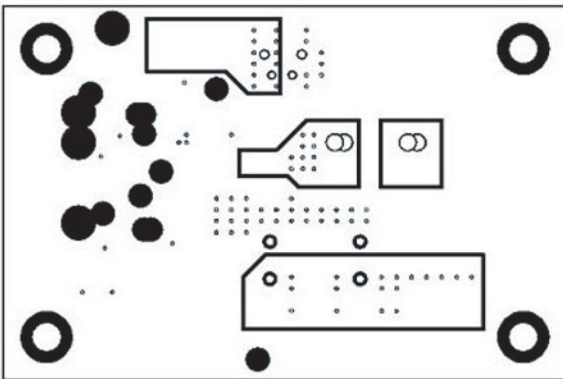

Figure 7. Internal Power Layer; 2nd Layer

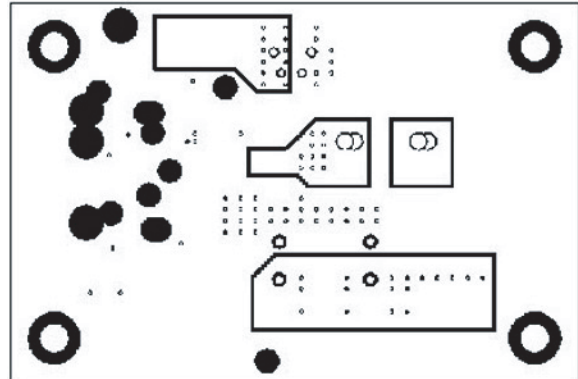

Figure 8. Internal Power Layer; 3rd Layer

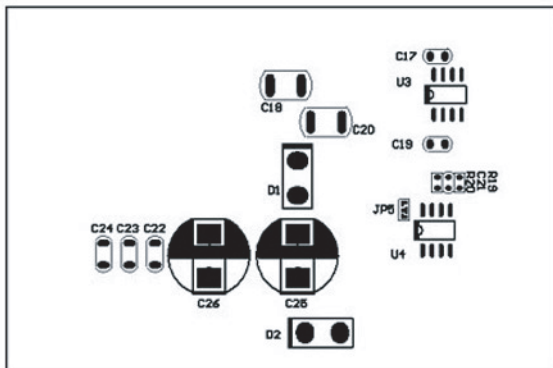

Figure 9. Bottom Silk Screen

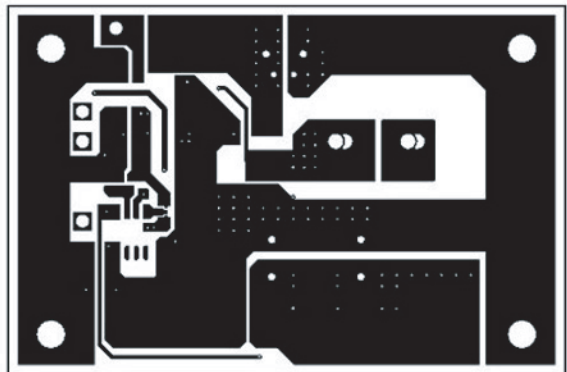
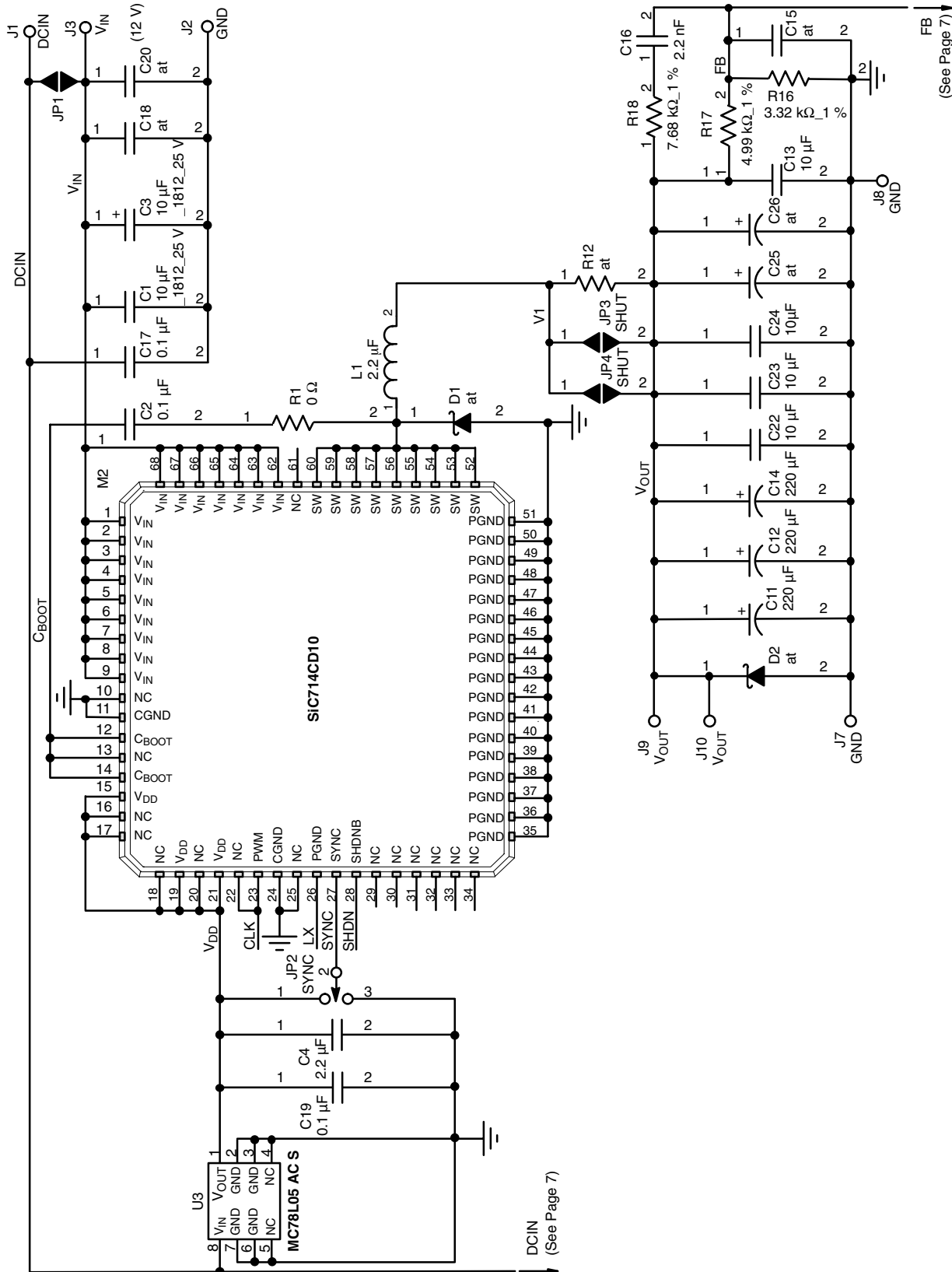

Figure 10. Bottom Layer



TABLE 5					
Bill-of-Materials of Sic714CD10 MOSFET plus driver EVB - SiDB766707					
Designator	Qty	Part Number	Description	Size	Manufacturer
M2	1	Sic714CD10	MLF 10 x 10, VDS 20 V	MLF10 x 10	Vishay
R1	1	CRCW0603000ZRT1	RES, 0 Ω 5 % 1/16 W 0603	603	Vishay
R2, R6, R7, R8, R9	5	CRCW0603103JRT1	RES, 10 kΩ 5 % 1/16 W 0603	603	
R3, R4	2	CRCW0603202JRT1	RES, 2 kΩ 5 % 1/16 W 0603	603	
R5	1	CRCW0603103JRT1	SiDB766707-B - RES, 10 kΩ 5 % 1/16 W 0603	603	
	1	CRCW06037681FRT1	SiDB766707-C -RES, 7.68 kΩ 1 % 1/16 W 0603	603	
	1	CRCW06033401FRT1	SiDB766707-D - RES, 3.4 kΩ, 1 % 1/16 W	603	
R10	1	CRCW0603100JRT1	RES, 10 Ω 5 % 1/16 W 0603	603	
R11	1	CRCW0603473JRT1	RES, 47 kΩ 5 % 1/16 W 0603	603	
R13	1	CRCW0603754JRT1	RES, 750 kΩ 5 % 1/16 W 0603	603	
R14, R15	2	CRCW06022632FRT1	RES, 22.6 kΩ 1 % 1/16 W 0603	603	
R16	1	CRCW06033321FRT1	RES, 3.32 kΩ 1 % 1/16 W 0603	603	
R17	1	CRCW06037681FRT1	SiDB766707-B - RES, 7.68 kΩ 1 % 1/16 W	603	
	1	CRCW06034991FRT1	SiDB766707-C -RES, 4.99 kΩ 1 % 1/16 W	603	
	1	CRCW06031001FRT1	SiDB766707-D - RES, 1 kΩ 1 % 1/16 W	603	
R18	1	CRCW06037681FRT1	SiDB766707-B - RES, 7.68 kΩ 1 % 1/16 W 0603	603	
	1	CRCW06037681FRT1	SiDB766707-C -RES, 7.68 kΩ 1 % 1/16 W 0603	603	
	1	CRCW06031240FRT1	SiDB766707-D - RES, 124 Ω , 1 % 1/16 W	603	
C1, C3	2	18123D106KAT2A	Ceramic CAP, 10 μF_1812_25 V, X5R	1812	Vishay
C2, C5, C8, C17, C19	5	VJ0805Y104KXAC W1BC	Ceramic CAP, 0.1 μF 50 V X7R 0805	805	
C4	1	VJ0805G225KXQC W1BC	Ceramic CAP, 2.2 μF 10 V X5R 0805	805	
C6	1	VJ0603Y562KXAAC	SiDB766707-B - CAP, 5.6 nF 50 V X7R 0603	603	
	1	VJ0603Y682KXAAC	SiDB766707-C -CAP, 6.8 nF 50 V X7R 0603	603	
	1	VJ0603Y153KXAAC	SiDB766707-D - CAP, 0.015 μF 50 V X7R	603	
C7	1	VJ0603Y221KXAAC	SiDB766707-B - CAP, 220 pF 50 V X7R 0603	603	
	1	VJ0603Y221KXAAC	SiDB766707-C -CAP, 220 pF 50 V X7R 0603	603	
	1	VJ0603Y182KXAAC	SiDB766707-D - CAP, 1800 pF 50 V X7R	603	
C9	1	VJ0603Y472KXAAC	Ceramic CAP, 4700 pF 50 V X7R 0603	603	
C10	1	VJ0603Y222KXAAC	Ceramic CAP, 2200 pF 50 V X7R 0603	603	
C11, C12, C14	3	594D227X0010D	CAP 220 μF	D	
C13, C22, C23, C24	4	VJ1206G106KXYC W1BC	Ceramic CAP, 10 μF 6.3 V X5R 1206	1206	
C16	1	VJ0603Y222KXAAC	SiDB766707-B - CAP, 2200 pF 50 V X7R	603	
	1	VJ0603Y222KXAAC	SiDB766707-C - CAP, 2200 pF 50 V X7R	603	
	1	VJ0603Y393KXAAC	SiDB766707-D - CAP, 0.039 μF 50 V X7R	603	
C25, C26	0	NOT POPULATED	CAP 220 μF	C	OSCON
Q1	1	TP0610T	P MOSFET TP0610T	SOT-23	Vishay
Q2	1	2N7002E	N MOSFET 2N7002E	SOT-23	
Q3	1	Si1032X	N MOSFET Si1032X	SC89-3	
U1	1	DG2012DL	Analog Switch	SC70-10	Vishay
U2	1	TL5001	PWM Controller	SO-8	Texas Instruments
U3	1	MC78L05 AC S	Linear Regulator	SO-8	Motorola
L1	1	IHLP-5050FD-ER3R3 or SSC-12808-3R1	SiDB766707 Ver 2 0 B Inductor 3 3 μH	13 x 13 mm 12.8 x 14.2 mm	Vishay
		IHLP-5050FD-ER2R2 or SSC-12808-2R2	SiDB766707 Ver 2 0 C Inductor 2 2 μH	13 x 13 mm 12.8 x 14.2 mm	Vishay
	1	IHLP-5050FD-ER1R5 or SSC-12808-1R5	SiDB766707 Ver 2 0 D Inductor 1 5 μH	13 x 13 mm 12.8 x 14.2 mm	Vishay

FIGURE 11. EVALUATION BOARD SCHEMATIC - PART 1 OF 2



© Reserved location

FIGURE 11. EVALUATION BOARD SCHEMATIC - PART 2 OF 2

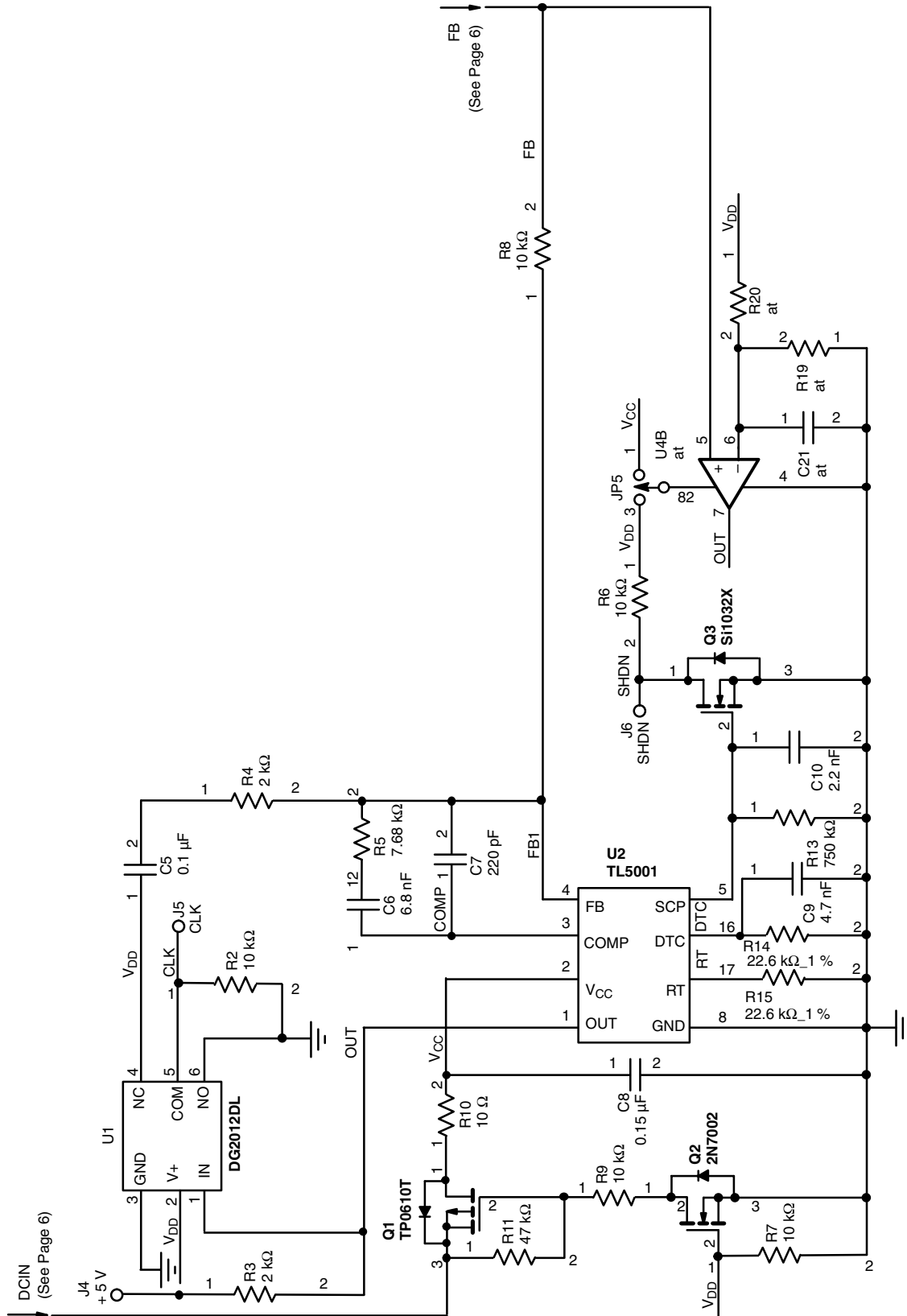

at Reserved location



EVALUATION BOARD DISCLAIMER

Vishay Siliconix (Vishay) provides this evaluation board (EVB) under the following conditions:

The EVB is intended for DEMONSTRATION OR ENGINEERING DEVELOPMENT OR EVALUATION PURPOSES ONLY and is not considered to be fit for commercial use. Vishay assumes no liability for application assistance, customer product design, infringement of patents, or software performance.

Please read the EVB datasheet carefully; it contains important information for its use. The user assumes all responsibility and liability for safe and proper handling of the EVB and to take any and all appropriate precautions concerning electrostatic discharge. Further, the user indemnifies Vishay from all claims arising from handling or use. The EVB is not regulatory-compliant or agency-certified. Any user handling the product must have electronics training and observe good laboratory practice standards.

THE EVB IS PROVIDED AS IS, WHERE IS, WITH NO WARRANTIES WHATSOEVER, EITHER EXPRESSED, IMPLIED, OR STATUTORY, AND SPECIFICALLY EXCLUDING THE WARRANTIES OF MERCHANTABILITY AND FITNESS FOR ANY PARTICULAR PURPOSE.

EXCEPT TO THE EXTENT OF THE INDEMNITY SET FORTH ABOVE, NEITHER PARTY SHALL BE LIABLE TO THE OTHER FOR ANY INDIRECT, SPECIAL, INCIDENTAL, OR CONSEQUENTIAL DAMAGES.

The EVB is not provided exclusively to the user and Vishay may supply the EVB to other users. No license is granted under any patent right or any other intellectual property right of Vishay.