

SOJ, TSOP, FP-BGA
Commercial Temp
Industrial Temp

512K x 8
4Mb Asynchronous SRAM

8, 10, 12 ns
3.3 V V_{DD}
Center V_{DD} and V_{SS}

Features

- Fast access time: 8, 10, 12 ns
- CMOS low power operation: 120/95/85 mA at minimum cycle time
- Single 3.3 V power supply
- All inputs and outputs are TTL-compatible
- Fully static operation
- Industrial Temperature Option: -40° to 85°C
- Package line up
 - J: 400 mil, 36-pin SOJ package
 - GJ: RoHS-compliant 400 mil, 36-pin SOJ package
 - TP: 400 mil, 44-pin TSOP-II package
 - GP: RoHS-compliant 400 mil, 44-pin TSOP-II package
 - X: 6 mm x 10 mm FPBGA package
 - GX: RoHS-compliant 6 mm x 10 mm FPBGA package
- RoHS-compliant packages available

Description

The GS74108A is a high speed CMOS Static RAM organized as 524,288 words by 8 bits. Static design eliminates the need for external clocks or timing strobes. The GS74108A operates on a single 3.3 V power supply and all inputs and outputs are TTL-compatible. The GS74108A is available in 400 mil SOJ, 400 mil TSOP-II, and 6 mm x 10 mm FPBGA packages.

Pin Descriptions

Symbol	Description
A ₀ –A ₁₈	Address input
DQ ₁ –DQ ₈	Data input/output
$\overline{\text{CE}}$	Chip enable input
$\overline{\text{WE}}$	Write enable input
$\overline{\text{OE}}$	Output enable input
V_{DD}	+3.3 V power supply
V_{SS}	Ground
NC	No connect

SOJ 512K x 8-Pin Configuration

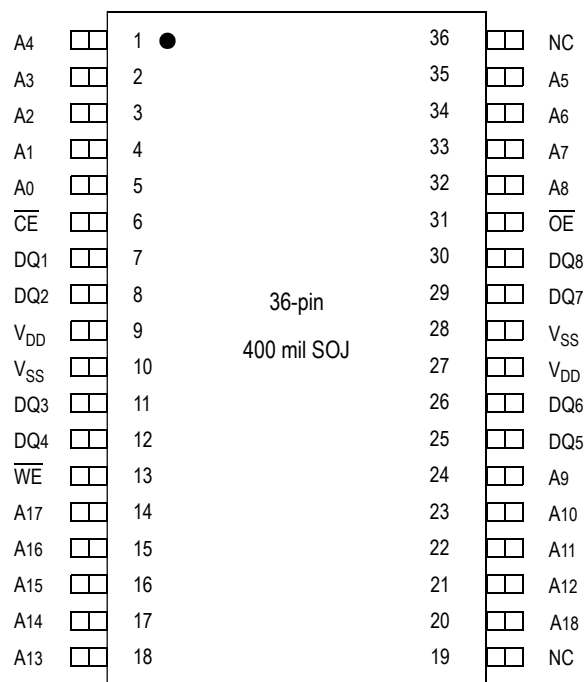

FP-BGA 512K x 8 Bump Configuration (Package X)

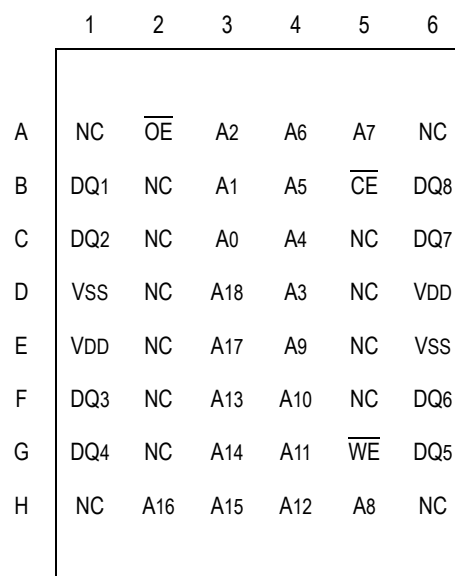

6 mm x 10 mm

***All GSI Technology packages are at least 5/6 RoHS compliant. Packages listed with the additional "G" designator are 6/6 RoHS compliant.**

TSOP-II 512K x 8-Pin Configuration

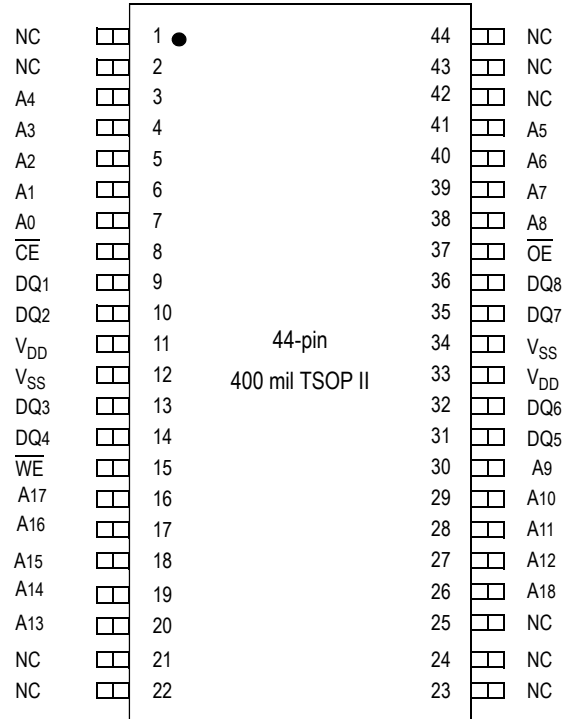

Block Diagram

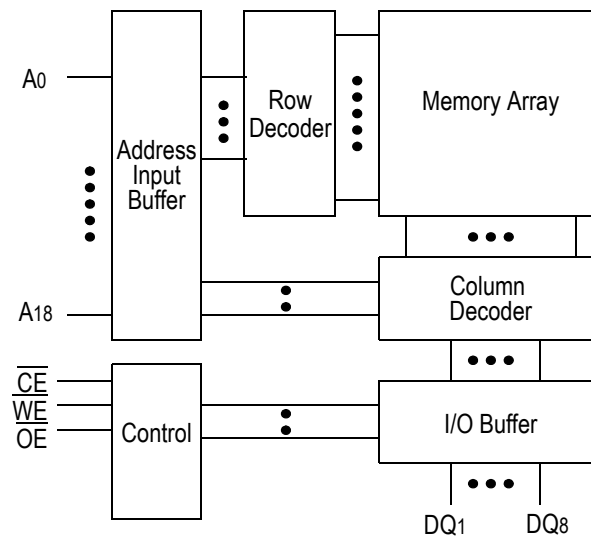

Truth Table

$\overline{\text{CE}}$	$\overline{\text{OE}}$	$\overline{\text{WE}}$	DQ1 to DQ8	V_{DD} Current
H	X	X	Not Selected	ISB1, ISB2
L	L	H	Read	IDD
L	X	L	Write	
L	H	H	High Z	

Note:

X: "H" or "L"

Absolute Maximum Ratings

Parameter	Symbol	Rating	Unit
Supply Voltage	V_{DD}	-0.5 to +4.6	V
Input Voltage	V_{IN}	-0.5 to $V_{\text{DD}} + 0.5$ (≤ 4.6 V max.)	V
Output Voltage	V_{OUT}	-0.5 to $V_{\text{DD}} + 0.5$ (≤ 4.6 V max.)	V
Allowable power dissipation	PD	0.7	W
Storage temperature	T_{STG}	-55 to 150	$^{\circ}\text{C}$

Note:

Permanent device damage may occur if Absolute Maximum Ratings are exceeded. Functional operation shall be restricted to Recommended Operating Conditions. Exposure to higher than recommended voltages for extended periods of time could affect device reliability.

Recommended Operating Conditions

Parameter	Symbol	Min	Typ	Max	Unit
Supply Voltage for -8/-10/-12	V_{DD}	3.0	3.3	3.6	V
Input High Voltage	V_{IH}	2.0	—	$V_{\text{DD}} + 0.3$	V
Input Low Voltage	V_{IL}	-0.3	—	0.8	V
Ambient Temperature, Commercial Range	T_{Ac}	0	—	70	$^{\circ}\text{C}$
Ambient Temperature, Industrial Range	T_{AI}	-40	—	85	$^{\circ}\text{C}$

Notes:

1. Input overshoot voltage should be less than $V_{\text{DD}} + 2$ V and not exceed 20 ns.
2. Input undershoot voltage should be greater than -2 V and not exceed 20 ns.

Capacitance

Parameter	Symbol	Test Condition	Max	Unit
Input Capacitance	C _{IN}	V _{IN} = 0 V	5	pF
Output Capacitance	C _{OUT}	V _{OUT} = 0 V	7	pF

Notes:

1. Tested at T_A = 25°C, f = 1 MHz
2. These parameters are sampled and are not 100% tested.

DC I/O Pin Characteristics

Parameter	Symbol	Test Conditions	Min	Max
Input Leakage Current	I _{IL}	V _{IN} = 0 to V _{DD}	-1 uA	1 uA
Output Leakage Current	I _{LO}	Output High Z V _{OUT} = 0 to V _{DD}	-1 uA	1 uA
Output High Voltage	V _{OH}	I _{OH} = -4 mA	2.4	—
Output Low Voltage	V _{OL}	I _{LO} = +4 mA	—	0.4 V

Power Supply Currents

Parameter	Symbol	Test Conditions	0 to 70°C			-40 to 85°C		
			8 ns	10 ns	12 ns	8 ns	10 ns	12 ns
Operating Supply Current	I _{DD}	$\overline{CE} \leq V_{IL}$ All other inputs $\geq V_{IH}$ or $\leq V_{IL}$ Min. cycle time I _{OUT} = 0 mA	120 mA	95 mA	85 mA	130 mA	105 mA	95 mA
Standby Current	I _{SB1}	$\overline{CE} \geq V_{IH}$ All other inputs $\geq V_{IH}$ or $\leq V_{IL}$ Min. cycle time	30 mA	25 mA	22 mA	40 mA	35 mA	32 mA
Standby Current	I _{SB2}	$\overline{CE} \geq V_{DD} - 0.2V$ All other inputs $\geq V_{DD} - 0.2V$ or $\leq 0.2V$	10 mA			20 mA		

AC Test Conditions

Parameter	Conditions
Input high level	$V_{IH} = 2.4\text{ V}$
Input low level	$V_{IL} = 0.4\text{ V}$
Input rise time	$t_r = 1\text{ V/ns}$
Input fall time	$t_f = 1\text{ V/ns}$
Input reference level	1.4 V
Output reference level	1.4 V
Output load	Fig. 1& 2

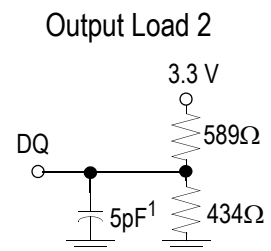
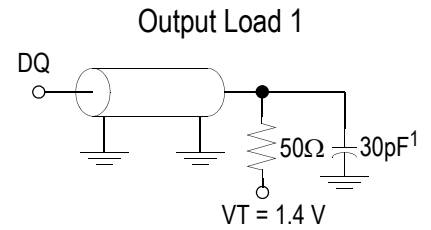
Notes:

1. Include scope and jig capacitance.
2. Test conditions as specified with output loading as shown in **Fig. 1** unless otherwise noted.
3. Output load 2 for tLZ, tHZ, toLZ and toHZ

AC Characteristics
Read Cycle

Parameter	Symbol	-8		-10		-12		Unit
		Min	Max	Min	Max	Min	Max	
Read cycle time	t _{RC}	8	—	10	—	12	—	ns
Address access time	t _{AA}	—	8	—	10	—	12	ns
Chip enable access time (\overline{CE})	t _{AC}	—	8	—	10	—	12	ns
Output enable to output valid (\overline{OE})	t _{OE}	—	3.5	—	4	—	5	ns
Output hold from address change	t _{OH}	3	—	3	—	3	—	ns
Chip enable to output in low Z (\overline{CE})	t _{LZ} *	3	—	3	—	3	—	ns
Output enable to output in low Z (\overline{OE})	t _{OLZ} *	0	—	0	—	0	—	ns
Chip disable to output in High Z (\overline{CE})	t _{HZ} *	—	4	—	5	—	6	ns
Output disable to output in High Z (\overline{OE})	t _{OHZ} *	—	3.5	—	4	—	5	ns

* These parameters are sampled and are not 100% tested.

Read Cycle 1: $\overline{CE} = \overline{OE} = V_{IL}, \overline{WE} = V_{IH}$

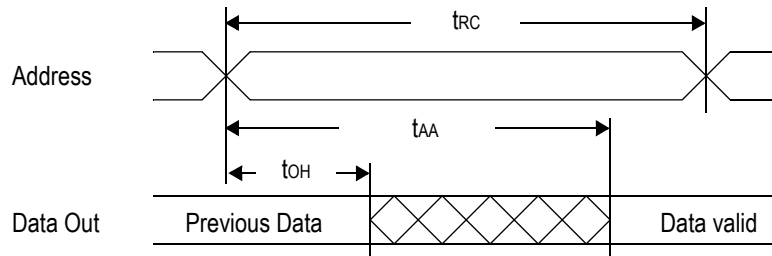

Read Cycle 2: $\overline{WE} = V_{IH}$

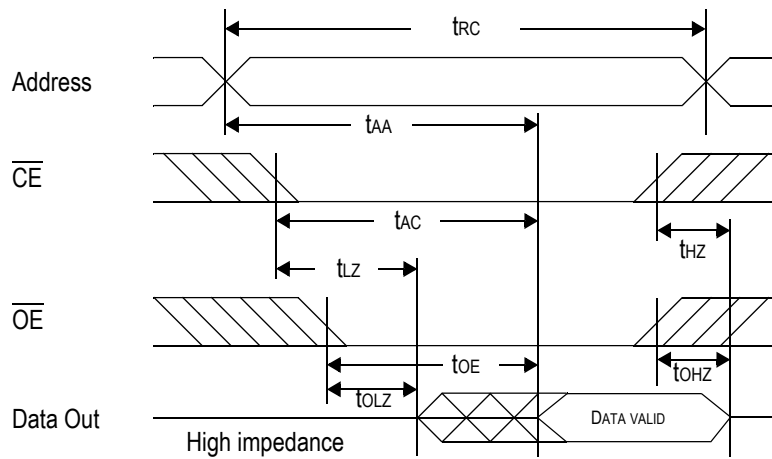

Write Cycle

Parameter	Symbol	-8		-10		-12		Unit
		Min	Max	Min	Max	Min	Max	
Write cycle time	tWC	8	—	10	—	12	—	ns
Address valid to end of write	tAW	5.5	—	7	—	8	—	ns
Chip enable to end of write	tCW	5.5	—	7	—	8	—	ns
Data set up time	tDW	4	—	5	—	6	—	ns
Data hold time	tDH	0	—	0	—	0	—	ns
Write pulse width	tWP	5.5	—	7	—	8	—	ns
Address set up time	tAS	0	—	0	—	0	—	ns
Write recovery time (\overline{WE})	tWR	0	—	0	—	0	—	ns
Write recovery time (\overline{CE})	tWR1	0	—	0	—	0	—	ns
Output Low Z from end of write	tWLZ*	3	—	3	—	3	—	ns
Write to output in High Z	tWHZ*	—	3.5	—	4	—	5	ns

* These parameters are sampled and are not 100% tested.

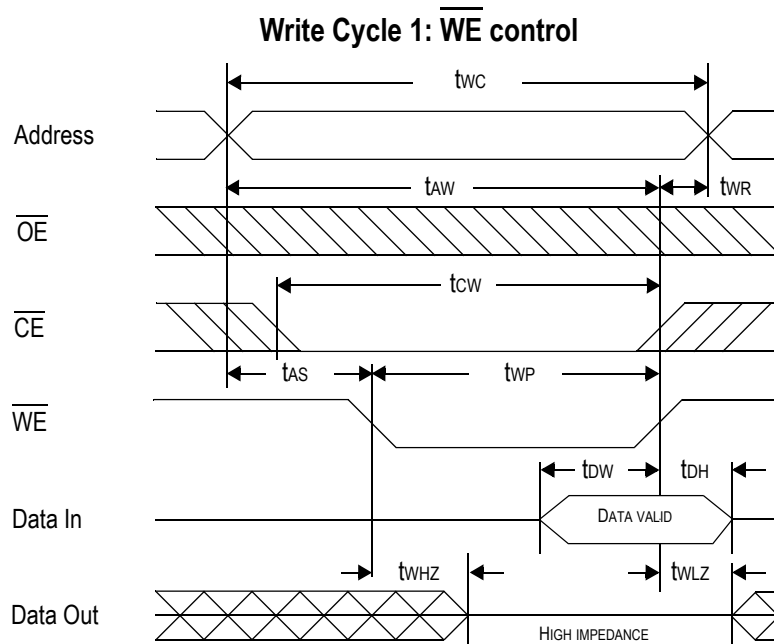

Write Cycle 2: \overline{CE} control

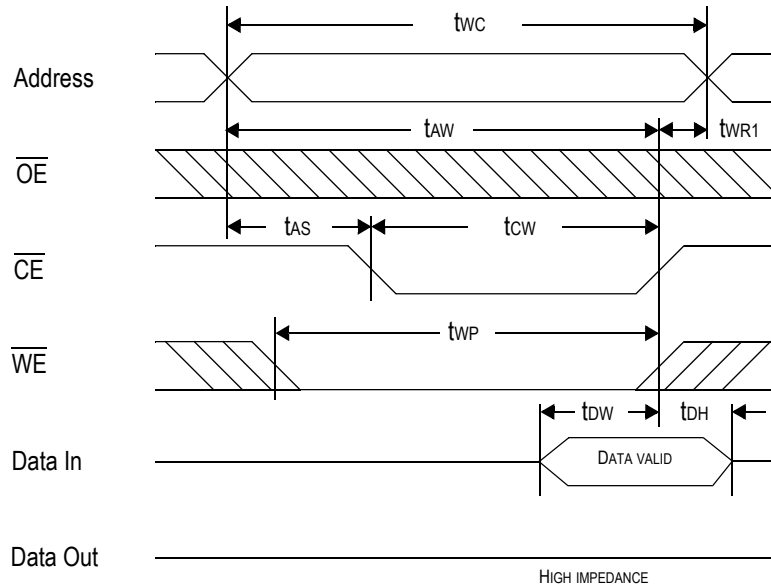

36-Pin SOJ, 400 mil

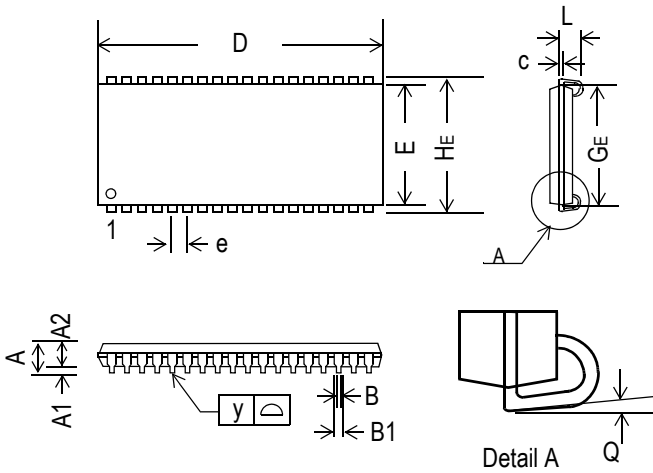

Symbol	Dimension in inch			Dimension in mm		
	min	nom	max	min	nom	max
A	—	—	0.146	—	—	3.70
A1	0.026	—	—	0.66	—	—
A2	0.105	0.110	0.115	2.67	2.80	2.92
B	0.013	0.017	0.021	0.33	0.43	0.53
B1	0.024	0.028	0.032	0.61	0.71	0.81
c	0.006	0.008	0.012	0.15	0.20	0.30
D	0.920	0.924	0.929	23.37	23.47	23.60
E	0.395	0.400	0.405	10.04	10.16	10.28
e	—	0.05	—	—	1.27	—
HE	0.430	0.435	0.440	10.93	11.05	11.17
GE	0.354	0.366	0.378	9.00	9.30	9.60
L	0.082	—	—	2.08	—	—
y	—	—	0.004	—	—	0.10
Q	0°	—	10°	0°	—	10°

Notes:

1. Dimension D & E do not include interlead flash.
2. Dimension B1 does not include dambar protrusion/intrusion.

44-Pin, 400 mil TSOP-II

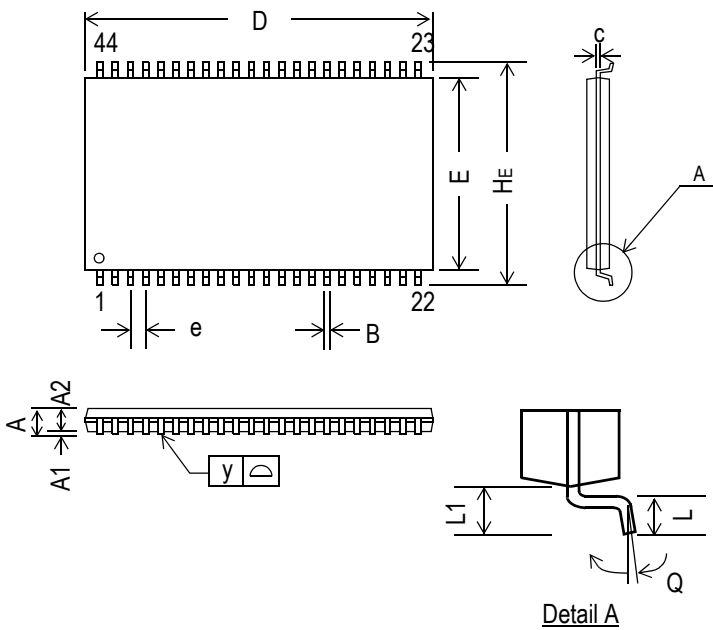

Symbol	Dimension in inch			Dimension in mm		
	min	nom	max	min	nom	max
A	—	—	0.047	—	—	1.20
A1	0.002	—	—	0.05	—	—
A2	0.037	0.039	0.041	0.95	1.00	1.05
B	0.01	0.014	0.018	0.25	0.35	0.45
c	—	0.006	—	—	0.15	—
D	0.721	0.725	0.729	18.31	18.41	18.51
E	0.396	0.400	0.404	10.06	10.16	10.26
e	—	0.031	—	—	0.80	—
HE	0.455	0.463	0.471	11.56	11.76	11.96
L	0.016	0.020	0.024	0.40	0.50	0.60
L1	—	0.031	—	—	0.80	—
y	—	—	0.004	—	—	0.10
Q	0°	—	5°	0°	—	5°

Notes:

1. Dimension D & E do not include interlead flash.
2. Dimension B does not include dambar protrusion/intrusion.
3. Controlling dimension: mm

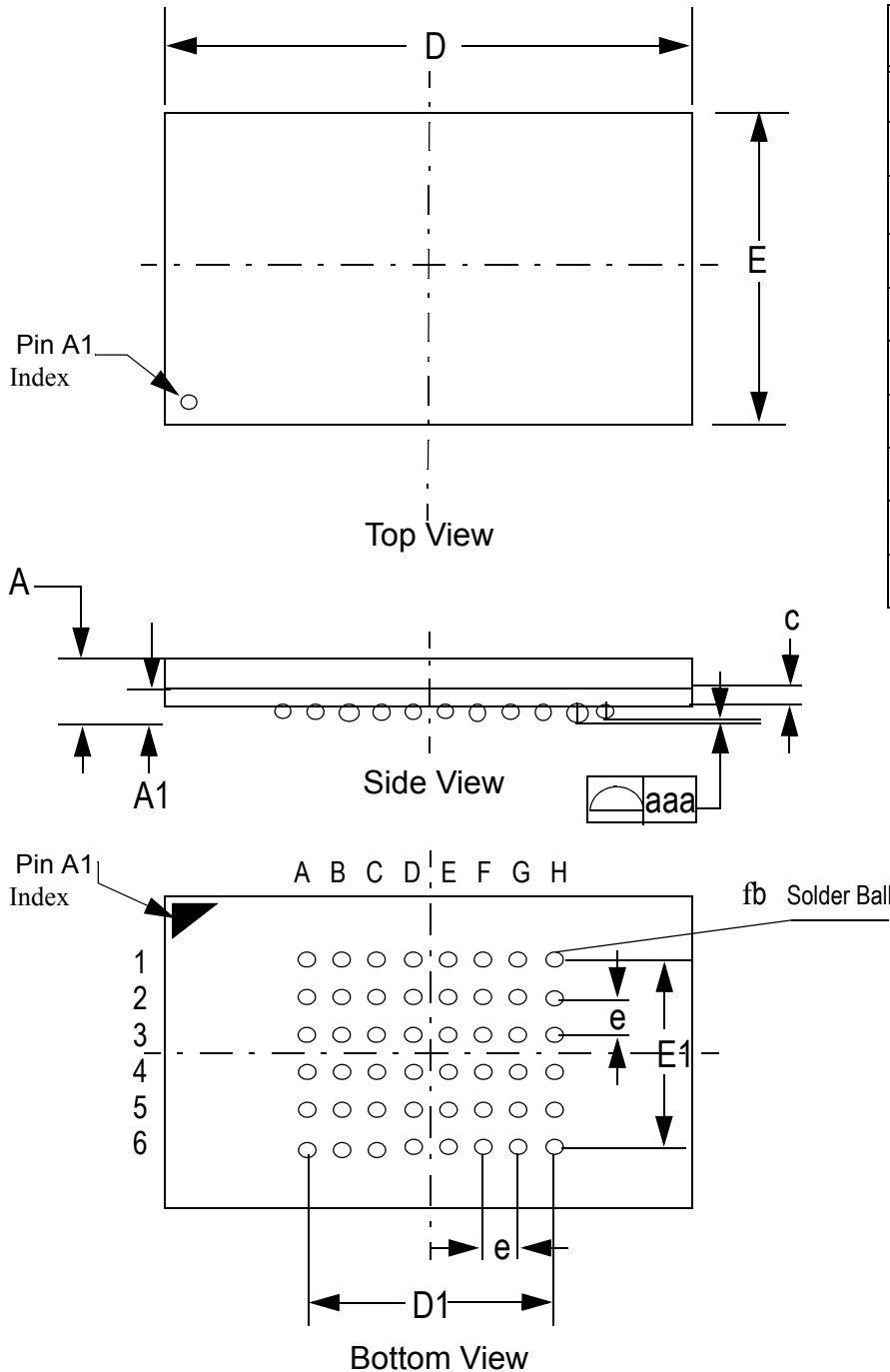
6 mm x 10 mm FPBGA

Symbol	Unit: mm
A	1.10±0.10
A1	0.20~0.30
fb	φ0.30~0.40
c	0.36(TYP)
D	10.0±0.05
D1	5.25
E	6.0±0.05
E1	3.75
e	0.75(TYP)
aaa	0.10

Ordering Information

Part Number¹	Package²	Access Time	Temp. Range	Status³
GS74108ATP-8	400 mil TSOP-II	8 ns	Commercial	MP
GS74108ATP-10	400 mil TSOP-II	10 ns	Commercial	MP
GS74108ATP-12	400 mil TSOP-II	12 ns	Commercial	MP
GS74108ATP-8I	400 mil TSOP-II	8 ns	Industrial	MP
GS74108ATP-10I	400 mil TSOP-II	10 ns	Industrial	MP
GS74108ATP-12I	400 mil TSOP-II	12 ns	Industrial	MP
GS74108AGP-8	RoHS-compliant 400 mil TSOP-II	8 ns	Commercial	PQ
GS74108AGP-10	RoHS-compliant 400 mil TSOP-II	10 ns	Commercial	PQ
GS74108AGP-12	RoHS-compliant 400 mil TSOP-II	12 ns	Commercial	PQ
GS74108AGP-8I	RoHS-compliant 400 mil TSOP-II	8 ns	Industrial	PQ
GS74108AGP-10I	RoHS-compliant 400 mil TSOP-II	10 ns	Industrial	PQ
GS74108AGP-12I	RoHS-compliant 400 mil TSOP-II	12 ns	Industrial	PQ
GS74108AJ-8	400 mil SOJ	8 ns	Commercial	MP
GS74108AJ-10	400 mil SOJ	10 ns	Commercial	MP
GS74108AJ-12	400 mil SOJ	12 ns	Commercial	MP
GS74108AJ-8I	400 mil SOJ	8 ns	Industrial	MP
GS74108AJ-10I	400 mil SOJ	10 ns	Industrial	MP
GS74108AJ-12I	400 mil SOJ	12 ns	Industrial	MP
GS74108AGJ-8	RoHS-compliant 400 mil SOJ	8 ns	Commercial	PQ
GS74108AGJ-10	RoHS-compliant 400 mil SOJ	10 ns	Commercial	PQ
GS74108AGJ-12	RoHS-compliant 400 mil SOJ	12 ns	Commercial	PQ
GS74108AGJ-8I	RoHS-compliant 400 mil SOJ	8 ns	Industrial	PQ
GS74108AGJ-10I	RoHS-compliant 400 mil SOJ	10 ns	Industrial	PQ
GS74108AGJ-12I	RoHS-compliant 400 mil SOJ	12 ns	Industrial	PQ
GS74108AX-8	6 mm x 10 mm FPBGA	8 ns	Commercial	MP
GS74108AX-10	6 mm x 10 mm FPBGA	10 ns	Commercial	MP
GS74108AX-12	6 mm x 10 mm FPBGA	12 ns	Commercial	MP
GS74108AX-8I	6 mm x 10 mm FPBGA	8 ns	Industrial	MP
GS74108AX-10I	6 mm x 10 mm FPBGA	10 ns	Industrial	MP

Ordering Information

Part Number¹	Package²	Access Time	Temp. Range	Status³
GS74108AX-12I	6 mm x 10 mm FPBGA	12 ns	Industrial	MP
GS74108AGX-8	RoHS-compliant 6 mm x 10 mm FPBGA	8 ns	Commercial	PQ
GS74108AGX-10	RoHS-compliant 6 mm x 10 mm FPBGA	10 ns	Commercial	PQ
GS74108AGX-12	RoHS-compliant 6 mm x 10 mm FPBGA	12 ns	Commercial	PQ
GS74108AGX-8I	RoHS-compliant 6 mm x 10 mm FPBGA	8 ns	Industrial	PQ
GS74108AGX-10I	RoHS-compliant 6 mm x 10 mm FPBGA	10 ns	Industrial	PQ
GS74108AGX-12I	RoHS-compliant 6 mm x 10 mm FPBGA	12 ns	Industrial	PQ

Notes:

1. Customers requiring delivery in Tape and Reel should add the character "T" to the end of the part number. For example: GS74108ATP-8T.
2. All GSI Technology packages are at least 5/6 RoHS compliant. Packages listed with the additional "G" designator are 6/6 RoHS compliant.
3. MP = Mass Production. PQ = Pre-Qualification.

4M Asynchronous Datasheet Revision History

Rev. Code: Old; New	Types of Changes Format or Content	Page #/Revisions/Reason
74108A_r1	Format/Content	• Creation of new datasheet
74108A_r1; 74108A_r1_01	Content	• Added 6 ns speed bin • Updated all power numbers
74108A_r1_01; 74108A_r1_02	Content	• Updated Recommended Operating Conditions table on page 4 • Added 7 ns bin to entire document • Added X package
74108A_r1_02; 74108A_r1_03	Content	• Removed 6 ns speed bin from entire document • Corrected "X" package pinout
74108A_r1_03; 74108A_r1_04	Content	• Removed 7 ns speed bin from entire document
74108A_r1_04; 74108A_r1_05	Content	• Updated format • Added Pb-free information for TSOP-II package
74108A_r1_05; 74108A_r1_06	Content	• Added Pb-free information for FP-BGA package
74108A_r1_06; 74108A_r1_07	Content	• Added RoHS-compliant information for SOJ • Changed Pb-free references to RoHS-compliant • Added status to ordering information table