

Atmel LED Drivers

MSL2160/MSL2161

16-string, White and RGB LED Drivers with Adaptive Configuration, EEPROM, and SPI/I²C/SMBus Serial Interface

Datasheet Brief



Atmel LED Drivers-MSL2160/MSL2161

16-string, White and RGB LED Drivers with Adaptive Configuration, EEPROM, and SPI/I²C/SMBus Serial Interface

General Description

The Atmel® LED Drivers-MSL2160 and MSL2161 compact, high-power LED string drivers use external current control MOSFETs to sink up to 350mA per string, with current accuracy and matching better than 1.5%. The MSL2160/1 drive 16 parallel strings of LEDs, and offer fault detection and management of open and short circuit LEDs.

The MSL2160 features a 20MHz SPI bus, and the MSL2161 offers a 1MHz I²C serial interface. Both interfaces support video frame-by-frame LED string intensity control for up to eight interconnected devices, allowing active area dimming and phase shifted PWM dimming for improved performance. Both devices include an advanced PWM engine that synchronizes PWM dimming to the video signal for reduced motion blur and waterfall noise.

The MSL2160/1 adaptively controls the DC-DC converters that power the LED strings using Atmel's Adaptive SourcePower™ technology. This scheme optimizes power consumption without sacrificing LED current accuracy. Peak LED string currents are set using current sense resistors, and global string current is adjustable with 8-bit control. Global string drive pulse width is adjusted with an 8-bit global intensity register, and individual string pulse width is modulated with 12-bit control.

The MSL2160/1 monitors the LED strings for open circuit, short circuit, loss-of-sync, and over-temperature faults, and provide a hardware fault output to notify the MCU. Detailed fault status and control are available through the serial interface. Additionally, the MSL2160/1 includes an on-chip EEPROM that allows the power-up defaults to be customized via the serial interface.

The MSL2160/1 are offered in 9 x 9 x 0.85mm, 64-pin TQFN packages and operate over a -40°C to +105°C temperature range.

Applications

Long Life, Efficient LED Backlighting for:

- Televisions and Desktop Monitors
- Medical and Industrial Instrumentation
- Automotive Audio-visual Displays

Channel Signs

Architectural Lighting

Ordering Information

16-CHANNEL LED STRING DRIVERS		
PART	INTERFACE	PACKAGE
MSL2160DQ	SPI	64-pin, 9 x 9 x 0.85mm TQFN
MSL2161DQ	I ² C	64-pin, 9 x 9 x 0.85mm TQFN

Atmel LED Drivers-MSL2160/MSL2161

16-string, White and RGB LED Drivers with Adaptive Configuration, EEPROM, and SPI/I²C/SMBus Serial Interface

Key Features

- 12-bit PWM String Dimming
- Fast Serial Interfaces Support up to 8 Devices per Bus:
 - MSL2161 - 1MHz I²C
 - MSL2160 - 20MHz SPI
- 8-bit Adaptive Power Correction Maximizes Efficiency of up to Three String Power Supplies
- External MOSFETs for High Voltage and/or Current
- Drives up to 16 Parallel LED Strings per Device
- Supports Adaptive, Real-time Area Dimming for Highest Dynamic Range in LCD TVs and Monitors
- Programmable String Phase Reduces Motion Blur and Improves Efficiency
- Global Intensity Control via Serial Interface
- ±1.5% Current Accuracy and Current Balance
- Flexible Video Frame (VSYNC) and Line (HSYNC) Sync Include Frequency Multipliers and Dividers
- Second Set of PWM Registers Select Alternate Brightness and Timing with Single Control
- EEPROM Saves Power-on Default Settings
- LED Open Circuit and Short Circuit Fault Detection
- Individual Fault Detection Enable for Each String
- Over-temperature Shut-off Protection
- Broadcast Write Simplifies Configuration
- -40°C To +105°C Operating Temperature Range

Application Circuit

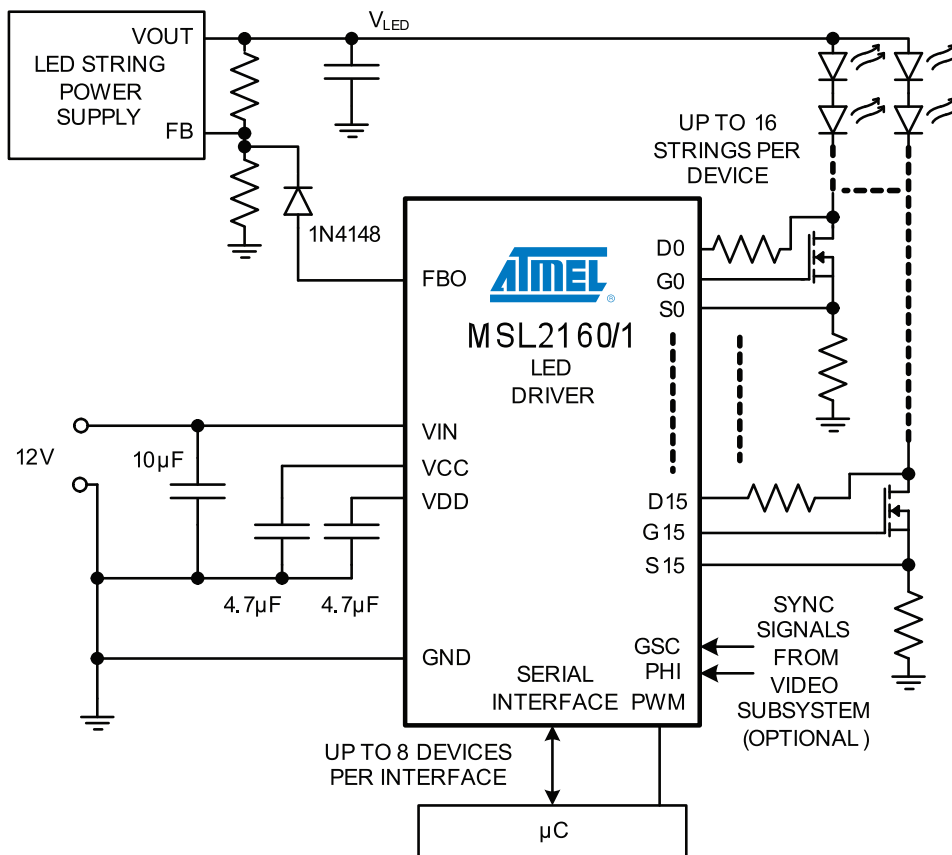



Atmel LED Drivers-MSL2160/61 Overview

The MSL2160/1 LED string controllers drive, monitor, and dim multiple LEDs at high efficiency for LCD backlighting and signage applications. This section summarizes the capabilities of the MSL2160/1 for quick evaluation.

How Many LEDs and Drivers?

The MSL2160/1 controls 16 strings of series-connected LEDs at up to 350mA per string. Up to eight MSL2160/1s share a serial interface. The maximum number of LEDs per string is determined by the maximum power supply voltage, the LED forward voltage drop (V_f), and the gate drive outputs of the MSL2160/1. The MSL2160/1 FET gate drive outputs are optimized for FETs requiring up to 10nC of charge.

LEDs, String Power Supplies and Efficiency Optimizers (EOs)

The MSL2160/1 Efficiency Optimizer (EO) circuits dynamically adjust up to three LED string power supplies to the minimum voltage necessary to accurately drive the LED strings while assuring accurate current flow. The power supplies can use any topology, and are typically DC-DC boost or buck, or AC-DC off-line switcher supplies.

The MSL2160/1 allows RGB LEDs to be driven by three separate string supplies, and feature three independent EO outputs to maximize the efficiency for each supply. Although not required, it is wise to use this capability even for single-color systems, such as white backlighting LEDs in an LCD monitor or TV application.

Timing, PWM, Intensity Controls and Synchronization

For video applications, the PWM LED drive signals synchronize to the LCD's video frame timing via the PHI input, and to the LCD's pixel timing via the GSC input. This synchronization eliminates beating artifacts. Suitability for LED backlight architectures is shown in Table 1. Area LED dimming for direct backlighting is supported for contrast and color gamut improvement. Motion blur is reduced by setting each LED string's PWM phasing individually to synchronize PWM off times with the LCD timing.

The MSL2160/1 also includes easily controlled internal PWM timing generation for stand alone (non-video) LED lighting applications that do not provide external timing sources. One MSL2160/1 simply generates PWM timing for itself and for the other devices in a multiple-device application. Optionally, a single external PWM signal applied to the PWM input controls all of the strings' on times, with automatic progressive phase delay available through a single control bit.

Table 1. LED Common Backlight Drive Architectures and Features

BACKLIGHT TYPE	MOTION BLUR REMOVAL	AREA DIMMING MANAGEMENT	STRING SUPPLY OPTIONS
White LED - bottom edge-lit	No	No	Up to three efficiency optimized power supplies
White LED - top/bottom edge-lit	No	No	
White LED - four sides edge-lit	No	No	
White LED - direct back-lit	Yes, LED string phasing	Higher contrast ratio (area dimming)	Three efficiency optimized power supplies
RGB LED - direct back-lit	Yes, LED string phasing	Higher contrast ratio and color gamut	

Atmel LED Drivers-MSL2160/MSL2161

16-string, White and RGB LED Drivers with Adaptive Configuration, EEPROM, and SPI/I²C/SMBus Serial Interface

Table 2. Timing and LED Intensity Control Capability

LED INTENSITY CONTROL	RESOLUTION
Global LED string current adjust	8-bits DAC reduces string current globally from maximum set by global resistor
Global LED string PWM	8-bit global PWM control
Individual LED string PWM	12-bit PWM individual string control
Total LED string PWM control	12-bit LED string PWMs, computed from global and individual PWM settings

Package Pin-out

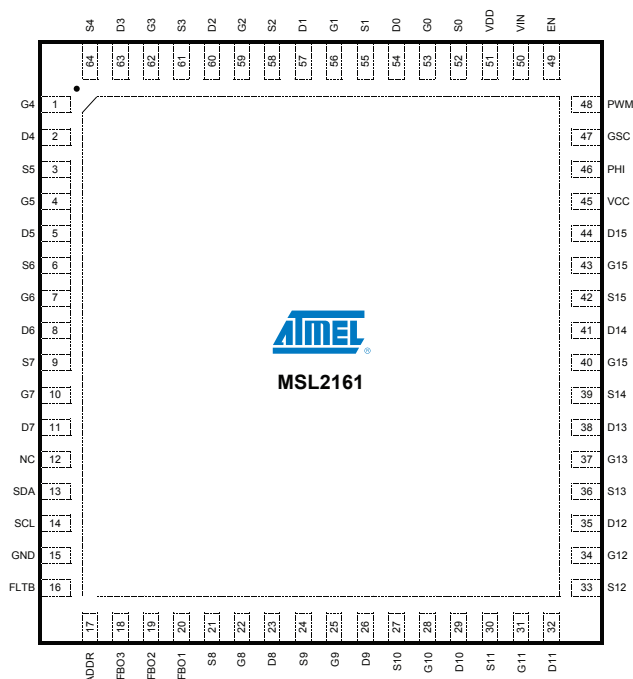

Figure 1. Atmel LED Driver-MSL2161 Pin-out, 64-pin TQFN.

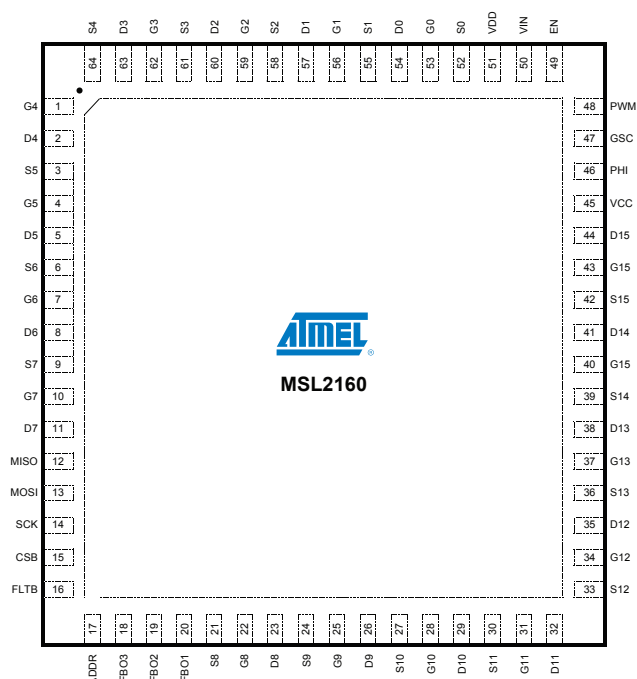
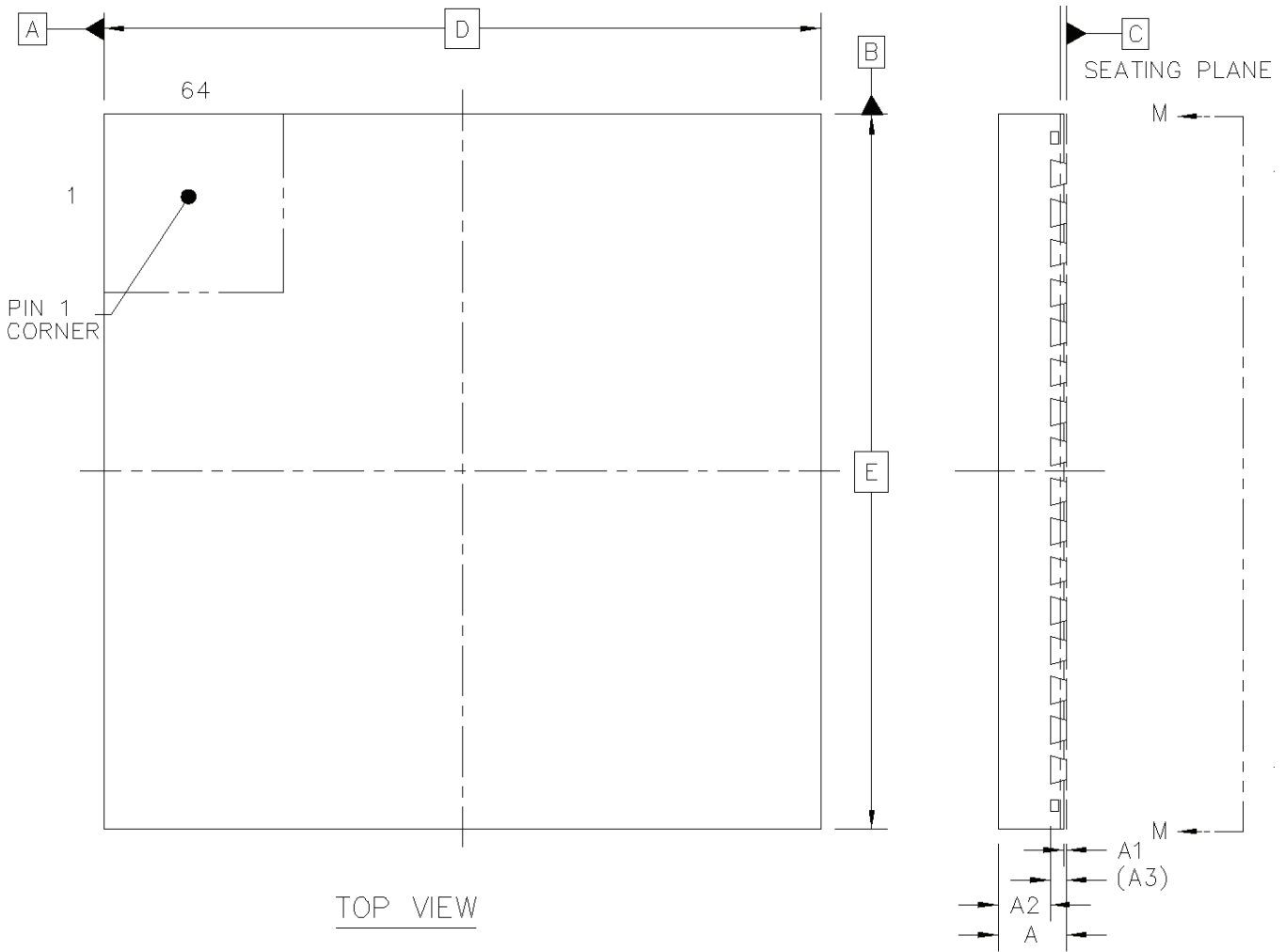

Figure 2. Atmel LED Driver-MSL2160 Pin-out, 64-pin TQFN.

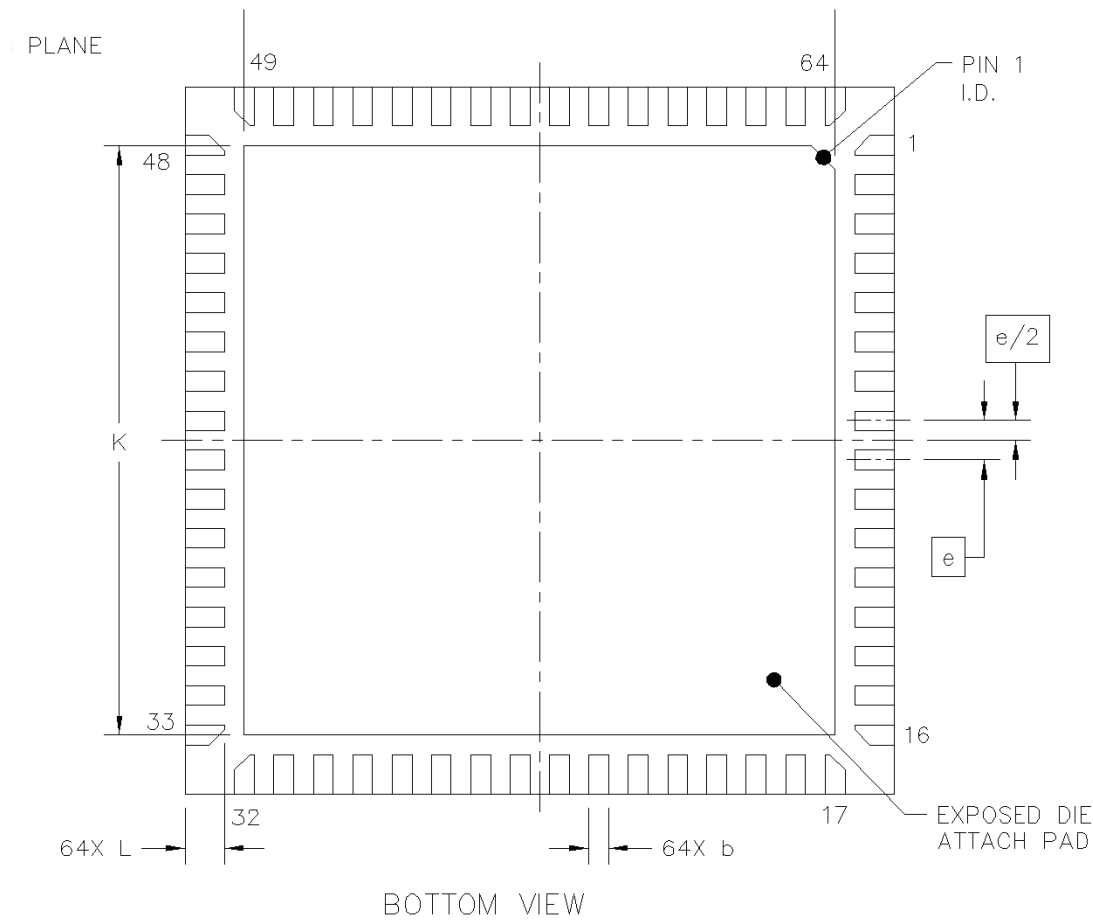

Figure 3. Package Dimensions: 64-pin, 9mm x 9mm x 0.85mm TQFN (0.5mm pin pitch) with Exposed Pad.



Atmel LED Drivers-MSL2160/MSL2161

16-string, White and RGB LED Drivers with Adaptive Configuration, EEPROM, and SPI/I²C/SMBus Serial Interface



		SYMBOL	MIN	NOM	MAX
TOTAL THICKNESS		A	0.8	0.85	0.9
STAND OFF		A1	0	0.035	0.05
MOLD THICKNESS		A2	---	0.65	0.67
L/F THICKNESS		A3	0.203 REF		
LEAD WIDTH		b	0.2	0.25	0.3
BODY SIZE	X	D	9 BSC		
	Y	E	9 BSC		
LEAD PITCH		e	0.5 BSC		
EP SIZE	X	J	7.4	7.5	7.6
	Y	K	7.4	7.5	7.6
LEAD LENGTH		L	0.45	0.5	0.55



Package Pin Descriptions

Table 3. Pin Assignments

PIN	PIN NAME		PIN DESCRIPTION
	MSL2161	MSL2160	
1	G4	G4	Gate output 4 Gate drive output for external MOSFET 4. Connect G4 to the gate of the external MOSFET driving LED string 4. If unused, leave G4 unconnected.
2	D4	D4	Drain sense input 4 Drain sense input for external MOSFET 4. Connect D4 through a 10M Ω resistor to the drain of the external MOSFET driving LED string 4. If unused, connect D4 to ground.
3	S5	S5	Source sense input 5 Source sense input for external MOSFET 5. Connect S5 to the source of the external MOSFET and to the current sense resistor for LED string 5. The full-scale LED current threshold is reached when 500mV is across the current sense resistor. If unused, connect S5 to ground.
4	G5	G5	Gate output 5 Gate drive output for external MOSFET 5. Connect G5 to the gate of the external MOSFET driving LED string 5. If unused, leave G5 unconnected.
5	D5	D5	Drain sense input 5 Drain sense input for external MOSFET 5. Connect D5 through a 10M Ω resistor to the drain of the external MOSFET driving LED string 5. If unused, connect D5 to ground.
6	S6	S6	Source sense input 6 Source sense input for external MOSFET 6. Connect S6 to the source of the external MOSFET and to the current sense resistor for LED string 6. The full-scale LED current threshold is reached when 500mV is across the current sense resistor. If unused, connect S6 to ground.
7	G6	G6	Gate output 6 Gate drive output for external MOSFET 6. Connect G6 to the gate of the external MOSFET driving LED string 6. If unused, leave G6 unconnected.
8	D6	D6	Drain sense input 6 Drain sense input for external MOSFET 6. Connect D6 through a 10M Ω resistor to the drain of the external MOSFET driving LED string 6. If unused, connect D6 to ground.
9	S7	S7	Source sense input 7 Source sense input for external MOSFET 7. Connect S7 to the source of the external MOSFET and to the current sense resistor for LED string 7. The full-scale LED current threshold is reached when 500mV is across the current sense resistor. If unused, connect S7 to ground.
10	G7	G7	Gate output 7 Gate drive output for external MOSFET 7. Connect G7 to the gate of the external MOSFET driving LED string 7. If unused, leave G7 unconnected.

Atmel LED Drivers-MSL2160/MSL2161

16-string, White and RGB LED Drivers with Adaptive Configuration, EEPROM, and SPI/I²C/SMBus Serial Interface

PIN	PIN NAME		PIN DESCRIPTION
	MSL2161	MSL2160	
11	D7	D7	Drain sense input 7 Drain sense input for external MOSFET 7. Connect D7 through a 10MΩ resistor to the drain of the external MOSFET driving LED string 7. If unused, connect D7 to ground.
12	NC	MISO	MSL2161: No connect Make no connection to NC.
			MSL2160: Master input slave output MISO is the SPI serial data output.
13	SDA	MOSI	MSL2161: I²C serial data I/O SDA is the data I/O for the I ² C serial interface.
			MSL2160: Master output slave input MOSI is the SPI serial data input.
14	SCL	SCK	MSL2161: I²C serial clock input SCL is the clock input for the I ² C serial interface.
			MSL2160: SPI serial shift clock SCK is the clock input for the SPI bus.
15	GND	CSB	MSL2161: Ground Connect GND to system ground and to EP with short, wide traces.
			MSL2160: Chip select bar CSB is the chip select input for SPI transactions. CSB is active low.
16	FLT B	FLT B	Fault indication output (active low) Open drain output FLT B sinks current to GND whenever a fault is detected and verified. FLT B remains low until the fault registers are read, and reasserts if the fault persists.
17	ADDR	ADDR	Slave ID selection inputs Connect ADDR to GND through a resistor to set the device address for the serial interface.
18	FBO3	FBO3	Efficiency Optimizer output 3 Connect FBO3 to the third power supply's feedback node. Connect FBO3 to GND if unused.
19	FBO2	FBO2	Efficiency Optimizer output 2 Connect FBO2 to the second power supply's feedback node. Connect FBO2 to GND if unused.
20	FBO1	FBO1	Efficiency Optimizer output 1 Connect FBO1 to the first power supply's feedback node. Connect FBO1 to GND if unused.
21	S8	S8	Source sense input 8 Source sense input for external MOSFET 8. Connect S8 to the source of the external MOSFET and to the current sense resistor for LED string 8. The full-scale LED current threshold is reached when 500mV is across the current sense resistor. If unused, connect S8 to ground.
22	G8	G8	Gate output 8 Gate drive output for external MOSFET 8. Connect G8 to the gate of the external MOSFET driving LED string 8. If unused, leave G8 unconnected.
23	D8	D8	Drain sense input 8 Drain sense input for external MOSFET 8. Connect D8 through a 10MΩ resistor to the drain of the external MOSFET driving LED string 8. If unused, connect D8 to ground.



Table 3. Pin Assignments

PIN	PIN NAME		PIN DESCRIPTION
	MSL2161	MSL2160	
24	S9	S9	Source sense input 9 Source sense input for external MOSFET 9. Connect S9 to the source of the external MOSFET and to the current sense resistor for LED string 9. The full-scale LED current threshold is reached when 500mV is across the current sense resistor. If unused, connect S9 to ground.
25	G9	G9	Gate output 9 Gate drive output for external MOSFET 9. Connect G9 to the gate of the external MOSFET driving LED string 9. If unused, leave G9 unconnected.
26	D9	D9	Drain sense input 9 Drain sense input for external MOSFET 9. Connect D9 through a 10MΩ resistor to the drain of the external MOSFET driving LED string 9. If unused, connect D9 to ground.
27	S10	S10	Source sense input 10 Source sense input for external MOSFET 10. Connect S10 to the source of the external MOSFET and to the current sense resistor for LED string 10. The full-scale LED current threshold is reached when 500mV is across the current sense resistor. If unused, connect S10 to ground.
28	G10	G10	Gate output 10 Gate drive output for external MOSFET 10. Connect G10 to the gate of the external MOSFET driving LED string 10. If unused, leave G10 unconnected.
29	D10	D10	Drain sense input 10 Drain sense input for external MOSFET 10. Connect D10 through a 10MΩ resistor to the drain of the external MOSFET driving LED string 10. If unused, connect D10 to ground.
30	S11	S11	Source sense input 11 Source sense input for external MOSFET 11. Connect S11 to the source of the external MOSFET and to the current sense resistor for LED string 11. The full-scale LED current threshold is reached when 500mV is across the current sense resistor. If unused, connect S11 to ground.
31	G11	G11	Gate output 11 Gate drive output for external MOSFET 11. Connect G11 to the gate of the external MOSFET driving LED string 11. If unused, leave G11 unconnected.
32	D11	D11	Drain sense input 11 Drain sense input for external MOSFET 11. Connect D11 through a 10MΩ resistor to the drain of the external MOSFET driving LED string 11. If unused, connect D11 to ground.
33	S12	S12	Source sense input 12 Source sense input for external MOSFET 12. Connect S12 to the source of the external MOSFET and to the current sense resistor for LED string 12. The full-scale LED current threshold is reached when 500mV is across the current sense resistor. If unused, connect S12 to ground.
34	G12	G12	Gate output 12 Gate drive output for external MOSFET 12. Connect G12 to the gate of the external MOSFET driving LED string 12. If unused, leave G12 unconnected.

Atmel LED Drivers-MSL2160/MSL2161

16-string, White and RGB LED Drivers with Adaptive Configuration, EEPROM, and SPI/I²C/SMBus Serial Interface

PIN	PIN NAME		PIN DESCRIPTION
	MSL2161	MSL2160	
35	D12	D12	Drain sense input 12 Drain sense input for external MOSFET 12. Connect D12 through a 10MΩ resistor to the drain of the external MOSFET driving LED string 12. If unused, connect D12 to ground.
36	S13	S13	Source sense input 13 Source sense input for external MOSFET 13. Connect S13 to the source of the external MOSFET and to the current sense resistor for LED string 13. The full-scale LED current threshold is reached when 500mV is across the current sense resistor. If unused, connect S13 to ground.
37	G13	G13	Gate output 13 Gate drive output for external MOSFET 13. Connect G13 to the gate of the external MOSFET driving LED string 13. If unused, leave G13 unconnected.
38	D13	D13	Drain sense input 13 Drain sense input for external MOSFET 13. Connect D13 through a 10MΩ resistor to the drain of the external MOSFET driving LED string 13. If unused, connect D13 to ground.
39	S14	S14	Source sense input 14 Source sense input for external MOSFET 14. Connect S14 to the source of the external MOSFET and to the current sense resistor for LED string 14. The full-scale LED current threshold is reached when 500mV is across the current sense resistor. If unused, connect S14 to ground.
40	G14	G14	Gate output 14 Gate drive output for external MOSFET 14. Connect G14 to the gate of the external MOSFET driving LED string 14. If unused, leave G14 unconnected.
41	D14	D14	Drain sense input 14 Drain sense input for external MOSFET 14. Connect D14 through a 10MΩ resistor to the drain of the external MOSFET driving LED string 14. If unused, connect D14 to ground.
42	S15	S15	Source sense input 15 Source sense input for external MOSFET 15. Connect S15 to the source of the external MOSFET and to the current sense resistor for LED string 15. The full-scale LED current threshold is reached when 500mV is across the current sense resistor. If unused, connect S15 to ground.
43	G15	G15	Gate output 15 Gate drive output for external MOSFET 15. Connect G15 to the gate of the external MOSFET driving LED string 15. If unused, leave G15 unconnected.
44	D15	D15	Drain sense input 15 Drain sense input for external MOSFET 15. Connect D15 through a 10MΩ resistor to the drain of the external MOSFET driving LED string 15. If unused, connect D15 to ground.
45	VCC	VCC	5V internal LDO regulator output VCC powers the FBO outputs. Bypass VCC to GND with a 4.7μF ceramic capacitor placed close to VCC.



Table 3. Pin Assignments

PIN	PIN NAME		PIN DESCRIPTION
	MSL2161	MSL2160	
46	PHI	PHI	Phase synchronization input Drive PHI with an external signal from 40Hz to 10kHz to synchronize the MSL2160/1 clock. PHI is typically driven with the VSYNC signal.
47	GSC	GSC	Gate shift clock input Drive GSC with the gate shift clock of the video signal, from to MHz. GSC is typically driven with the HSYNC signal.
48	PWM	PWM	PWM input PWM allows external control of the brightness of all LED strings. Drive PWM with a pulse-width modulated signal with duty cycle ranging from 0% to 100% and frequency up to 5kHz. When not configured as an input, PWM is high impedance.
49	EN	EN	Enable input (active high) Drive EN high to turn on the MSL2160/1, drive EN low to turn off the MSL2160/1. For automatic start up, connect EN to VIN. When EN is low the entire device, including the serial interface, is turned off. Driving EN high initiates a boot load of the EEPROM data into the control registers, simulating a cold start up.
50	VIN	VIN	Supply voltage input Connect a 12V \pm 10% supply to VIN. Bypass VIN to GND with a 10 μ F ceramic capacitor placed close to VIN.
51	VDD	VDD	2.5V internal LDO regulator output VDD powers internal logic. Bypass VDD to GND with a 4.7 μ F ceramic capacitor placed close to VDD.
52	S0	S0	Source sense input 0 Source sense input for external MOSFET 0. Connect S0 to the source of the external MOSFET and to the current sense resistor for LED string 0. The full-scale LED current threshold is reached when 500mV is across the current sense resistor. If unused, connect S0 to ground.
53	G0	G0	Gate output 0 Gate drive output for external MOSFET 0. Connect G0 to the gate of the external MOSFET driving LED string 0. If unused, leave G0 unconnected.
54	D0	D0	Drain sense input 0 Drain sense input for external MOSFET 0. Connect D0 through a 10M Ω resistor to the drain of the external MOSFET driving LED string 0. If unused, connect D0 to ground.
55	S1	S1	Source sense input 1 Source sense input for external MOSFET 1. Connect S1 to the source of the external MOSFET and to the current sense resistor for LED string 1. The full-scale LED current threshold is reached when 500mV is across the current sense resistor. If unused, connect S1 to ground.
56	G1	G1	Gate output 1 Gate drive output for external MOSFET 1. Connect G1 to the gate of the external MOSFET driving LED string 1. If unused, leave G1 unconnected.

Atmel LED Drivers-MSL2160/MSL2161

16-string, White and RGB LED Drivers with Adaptive Configuration, EEPROM, and SPI/I²C/SMBus Serial Interface

PIN	PIN NAME		PIN DESCRIPTION
	MSL2161	MSL2160	
57	D1	D1	Drain sense input 1 Drain sense input for external MOSFET 1. Connect D1 through a 10MΩ resistor to the drain of the external MOSFET driving LED string 1. If unused, connect D1 to ground.
58	S2	S2	Source sense input 2 Source sense input for external MOSFET 2. Connect S2 to the source of the external MOSFET and to the current sense resistor for LED string 2. The full-scale LED current threshold is reached when 500mV is across the current sense resistor. If unused, connect S2 to ground.
59	G2	G2	Gate output 2 Gate drive output for external MOSFET 2. Connect G2 to the gate of the external MOSFET driving LED string 2. If unused, leave G2 unconnected.
60	D2	D2	Drain sense input 2 Drain sense input for external MOSFET 2. Connect D2 through a 10MΩ resistor to the drain of the external MOSFET driving LED string 2. If unused, connect D2 to ground.
61	S3	S3	Source sense input 3 Source sense input for external MOSFET 3. Connect S3 to the source of the external MOSFET and to the current sense resistor for LED string 3. The full-scale LED current threshold is reached when 500mV is across the current sense resistor. If unused, connect S3 to ground.
62	G3	G3	Gate output 3 Gate drive output for external MOSFET 3. Connect G3 to the gate of the external MOSFET driving LED string 3. If unused, leave G3 unconnected.
63	D3	D3	Drain sense input 3 Drain sense input for external MOSFET 3. Connect D3 through a 10MΩ resistor to the drain of the external MOSFET driving LED string 3. If unused, connect D3 to ground.
64	S4	S4	Source sense input 4 Source sense input for external MOSFET 4. Connect S4 to the source of the external MOSFET and to the current sense resistor for LED string 4. The full-scale LED current threshold is reached when 500mV is across the current sense resistor. If unused, connect S4 to ground.
EP	EP	EP	Exposed pad, power ground EP is the thermal relief pad for the device. Connect EP to system ground and GND using short, wide traces.



Absolute Maximum Ratings

Voltage (With Respect to GND)

VIN, EN, D0 - D15	-0.3V to +16V
G0 - G15	-0.3V to (VIN + 0.3V)
VDD	-0.3V to +2.75V
ADDR, S0 - S15	-0.3V to (VDD + 0.3V)
FLTb, SDA, SCL, SCK	-0.3V to +5.5V
FBO1, FBO2, FBO3, PHI, GSC, PWM, MOSI, MISO, CSB	-0.3V to (VCC + 0.3V)
VCC	-0.3V to +6V
EP	-0.3V to +0.3V

Current (Into Pin)

VIN	500mA
FBO1, FBO2, FBO3	+0 μ A to -800 μ A
G0 - G15	\pm 100mA
All other pins	\pm 20mA

Continuous Power Dissipation

64-Pin 9mm x 9mm QFN (derate 38mW/°C above T _A = +70°C)	2100mW
--	--------

Ambient Operating Temperature Range T_A = T_{MIN} to T_{MAX}

-40°C to +105°C

Junction Temperature

+125°C

Storage Temperature Range

-65°C to +125°C

Lead Soldering Temperature, 10s

+300°C

Atmel LED Drivers-MSL2160/MSL2161

16-string, White and RGB LED Drivers with Adaptive Configuration, EEPROM, and SPI/I²C/SMBus Serial Interface

Electrical Characteristics

Typical Application Circuit, $V_{VIN} = 12V$, $T_A = T_{MIN}$ to T_{MAX} , unless otherwise noted. Typical values are $T_A = +25^{\circ}C$

PARAMETER	SYMBOL	CONDITIONS AND NOTES	MIN	TYP	MAX	UNIT
DC ELECTRICAL CHARACTERISTICS						
VIN Operating Supply Voltage			10.8	12	13.2	V
VIN Operating Supply Current		All LED strings on 50% duty cycle		15	30	mA
		All LED strings on 100% duty cycle		30	70	
VIN Shutdown Supply Current		EN = GND		500		μA
VIN Sleep Supply Current		SLEEP = 1, SDA, SCL, ADDR, PWM, PHI and GSC at GND or VDD		2.75		mA
VCC Regulation Voltage			4.5	5.0	5.5	V
VDD Regulation Voltage			2.4	2.5	2.6	V
EN Input High Voltage			1.8			V
EN Input Low Voltage					0.9	V
PWM, PHI, GSC, Input High Voltage			$0.7 \times V_{VDD}$			V
PWM, PHI, GSC, Input Low Voltage					$0.3 \times V_{VDD}$	V
PHI, GSC Output High Voltage		$I_{SOURCE} = 5mA$	$V_{VDD} - 0.4$			
PHI, GSC, FLTB Output Low Voltage		$I_{SINK} = 6mA$			0.4	V
FBO1 - FBO3 Feedback Output Current		FBO _n DAC = 0xFF, $V_{FBO_n} = 0$	208	306	360	μA
FBO1 - FBO3 Feedback Output Current Step		INCRSTEP[0:1] = 00, DECRSTEP[0:1] = 00		1.2		μA
D0 - D15 Short Circuit Fault Detection Threshold				8		V
G0 - G15 Open Circuit Fault Detection Threshold				8		V
G0 - G15 Maximum Gate Drive Current			0.7			mA
G0 - G15 Maximum Gate Drive Voltage			$V_{VIN} - 2.5$			V
S0 - S15 Regulation Voltage		ISTR = 0xFF	475	500	525	mV
S0 - S15 Voltage Accuracy		ISTR = 0x7F, $T_A = +25^{\circ}C$	-1.5		+1.5	%
		ISTR = 0x7F	-4		+4	
S0 - S15 Regulation Voltage Matching		ISTR = 0x7F, $T_A = +25^{\circ}C$, 1 st string to all others	-0.5		+0.5	%
		ISTR = 0x7F, string to average of all strings	-1.5		+1.5	
Thermal Shutdown Temperature		Temperature rising, hysteresis = 15°C (Note 1)		135		$^{\circ}C$



PARAMETER	SYMBOL	CONDITIONS AND NOTES	MIN	TYP	MAX	UNIT
SPI LOGIC LEVELS, MSL2160						
MOSI, SCK, CSB Input High Voltage			$0.7 \times V_{VDD}$			V
MOSI, SCK, CSB Input Low Voltage					$0.3 \times V_{VDD}$	V
MISO Output High Voltage		$I_{SOURCE} = 5mA$	$V_{VCC} - 0.4$			V
MISO Output Low Voltage		$I_{SINK} = 6mA$			0.4	V

PARAMETER	SYMBOL	CONDITIONS AND NOTES	MIN	TYP	MAX	UNIT
I²C LOGIC LEVELS, MSL2161						
SDA, SCL Input High Voltage			$0.7 \times V_{VDD}$			V
SDA, SCL Input Low Voltage					$0.3 \times V_{VDD}$	V
SDA Output Low Voltage		$I_{SINK} = 6mA$			0.4	V

PARAMETER	SYMBOL	CONDITIONS AND NOTES	MIN	TYP	MAX	UNIT
AC ELECTRICAL CHARACTERISTICS						
Internal Oscillator Frequency	f_{OSC}	OSCFREQ = 0x04, $T_A = 25^\circ C$	19.4	20	20.6	MHz
PHI Frequency	f_{PHI}		0.04		10	kHz
GSC Frequency		GSCMUL = 0, GSCDIV = 0 (Note 9)	f_{PHI}		2.5	MHz
PWM Frequency		EXTALTEN = 0 (Note 1)			5	kHz
		EXTALTEN = 1 (Note 1)			1	
PWM Duty Cycle		(Note 1, Note 9)	0		100	%

PARAMETER	SYMBOL	CONDITIONS AND NOTES	MIN	TYP	MAX	UNIT
SPI TIMING CHARACTERISTICS, MSL2160						
SCK Frequency					20	MHz
CSB to Rising Edge of SCK Setup Time	$t_{CSB:SCK(SU)}$		20			ns
Rising Edge of SCK to CSB Hold Time	$t_{CSB:SCK(HD)}$		20			ns
MOSI to Rising Edge of SCK Setup Time	$t_{MOSI(SU)}$		20			ns
Rising Edge of SCK to MOSI Hold Time	$t_{MOSI(HD)}$		20			ns
CSB Falling Edge to MISO Data Valid	$t_{CSB:MISO(DV)}$				50	ns
CSB Rising Edge to MISO High Impedance	$t_{CSB:MISO(HIZ)}$	(Note 1)			50	ns

Atmel LED Drivers-MSL2160/MSL2161

16-string, White and RGB LED Drivers with Adaptive Configuration, EEPROM, and SPI/I²C/SMBus Serial Interface

PARAMETER	SYMBOL	CONDITIONS AND NOTES	MIN	TYP	MAX	UNIT
SCK Falling Edge to MISO Data Valid	t_{VALID}	(Note 1)			20	ns
SCK High Time			20			ns
SCK Low Time			20			ns
MOSI, CSB, SCK Signal Rise Time	$t_{\text{R(SPI)}}$	Receiving (Note 6)		5.0		ns
MOSI, CSB, SCK Signal Fall Time	$t_{\text{F(SPI)}}$	Receiving (Note 6)		5.0		ns
MISO Signal Rise Time		$C_{\text{load}} = 10\text{pF}$ (Note 6)		20		ns
MISO Signal Fall Time		$C_{\text{load}} = 10\text{pF}$ (Note 6)		20		ns

PARAMETER	SYMBOL	CONDITIONS AND NOTES	MIN	TYP	MAX	UNIT
I²C TIMING CHARACTERISTICS, MSL2161						
SCL Clock Frequency	$1/t_{\text{SCL}}$	I2CTOEN = 0 (Note 2)	0		1	MHz
Bus Timeout Period	t_{timeout}	$f_{\text{OSC}} = 20\text{MHz}$, $T_{\text{A}} = 25^{\circ}\text{C}$	29	30	31	ms
		$f_{\text{OSC}} = 16\text{MHz to } 23\text{MHz}$	$600,000 / f_{\text{OSC}}$			s
STOP to START Condition Bus Free Time	t_{BUF}		0.5			μs
Repeated START condition Hold Time	$t_{\text{HD:STA}}$		0.26			μs
Repeated START condition Setup Time	$t_{\text{SU:STA}}$		0.26			μs
STOP Condition Setup Time	$t_{\text{SU:STOP}}$		0.26			μs
SDA Data Hold Time	$t_{\text{HD:DAT}}$		0			ns
SDA Data Valid Acknowledge Time	$t_{\text{VD:ACK}}$	(Note 3)	0.05		0.45	μs
SDA Data Valid Time	$t_{\text{VD:DAT}}$	(Note 4)	0.05		0.45	μs
SDA Data Set-Up Time	$t_{\text{SU:DAT}}$		100			ns
SCL Clock Low Period	t_{LOW}		0.5			μs
SCL Clock High Period	t_{HIGH}		0.26			μs
SDA, SCL Fall Time	t_{f}	(Note 1, Note 5, Note 6)			120	ns
SDA, SCL Rise Time	t_{r}				120	ns
SDA, SCL Input Suppression Filter Period	t_{SP}	(Note 2, Note 7)		50		ns

Note 1. Guaranteed by design, not production tested.

Note 2. Minimum SCL clock frequency is limited by the bus timeout feature, which resets the serial bus interface if either SDA or SCL is held low for time-out. Disable bus timeout via the Fault Enable register 0x03[D6].

Note 3. $t_{\text{VD:ACK}} = \text{SCL LOW to SDA (out) LOW acknowledge time}$.

Note 4. $t_{\text{VD:DAT}} = \text{minimum SDA output data-valid time following SCL LOW transition}$.

Note 5. A master device must internally provide an SDA hold time of at least 300ns to ensure an SCL low state.

Note 6. The maximum SDA, SCL and MOSI rise times are 300ns. This allows series protection resistors to be connected between these inputs and the bus lines without exceeding the maximum allowable rise time. The maximum SDA and MISO fall time is 250ns.

Note 7. The MSL2161 includes input filters on SDA, SCL and ADDR inputs that suppress noise less than 50ns.

Note 8. The GSC input frequency multiplied by (GSCMUL + 1) should not exceed 2.5MHz.

Note 9. When PWMDIRECT = 1 and PHDLYEN = 1 (external PWM with auto phase shift enabled), PWM duty cycles at 0% and 100% are guaranteed, other duty cycles require minimum on or off time of one full internal oscillator clock cycle and frequency greater than $(f_{\text{osc}}/10^6)\text{Hz}$.

Typical Application Circuit

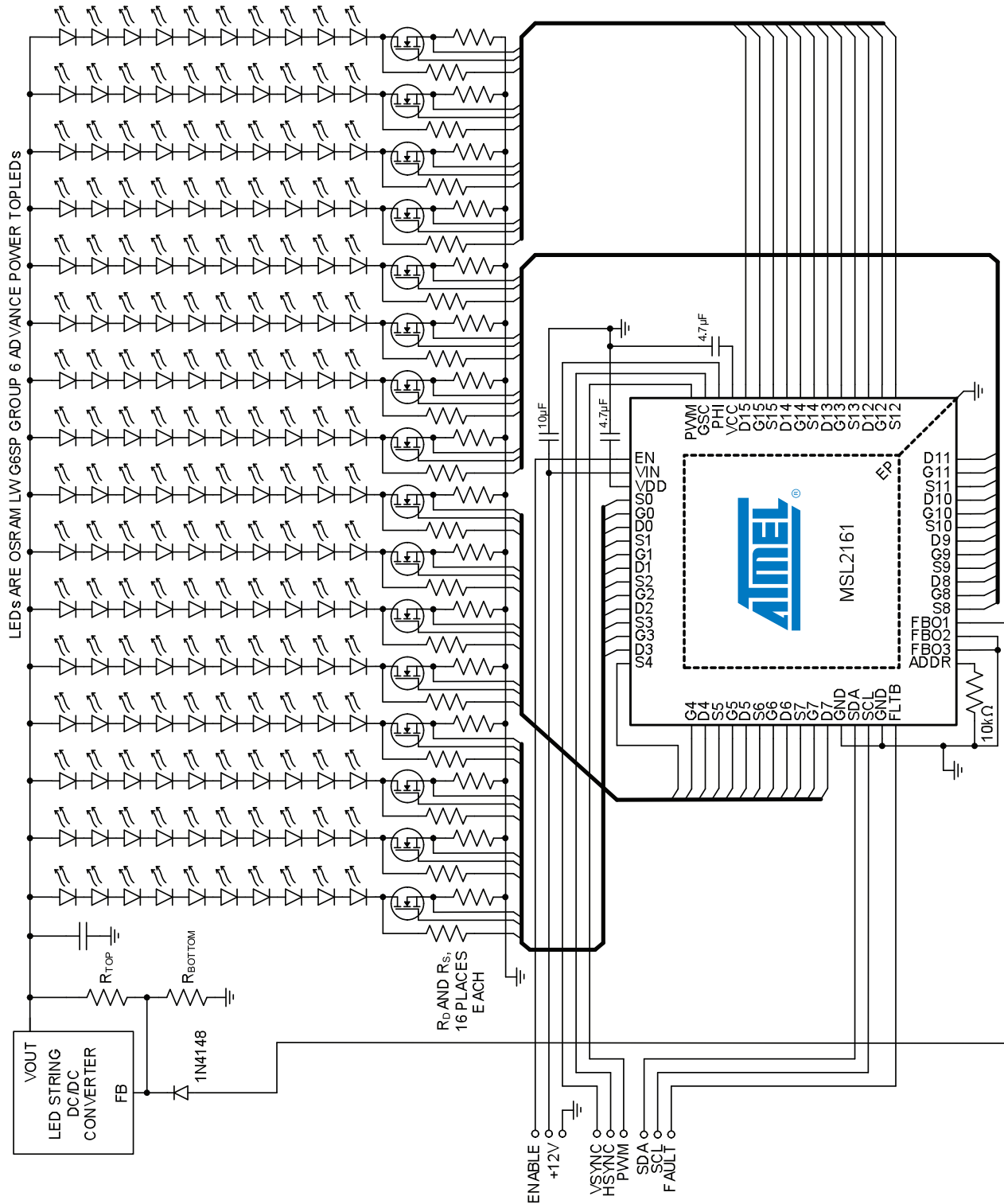

Figure 4. Atmel LED Driver-MSL2161 Driving 160 White LEDs in 16 Strings

Atmel LED Drivers-MSL2160/MSL2161

16-string, White and RGB LED Drivers with Adaptive Configuration, EEPROM, and SPI/I²C/SMBus Serial Interface

Detailed Description

The MSL2160 and MSL2161 are highly integrated, flexible, multi-string LED drivers that use external MOSFETs to allow high LED string currents, and include power supply control to maximize efficiency. The drivers optionally connect to a video subsystem to offer a simple architecture for use in LCD TV backlight applications. Up to eight devices can be cascaded together to drive large numbers of LED strings in a system. The drivers provide multiple methods of controlling LED brightness through both peak current control and pulse width control of the string drive signals. Peak current control offers excellent color consistency, while pulse width control allows brightness management. An on-chip EEPROM holds all the default control register values. At power-up, the data in the EEPROM are automatically copied directly to the control registers, setting up the device for operation. The factory programmed EEPROM values can be changed through the serial interface if a different power-up condition is desired.

The devices interface to an MCU via I²C (MSL2161) or SPI (MSL2160). The robust 1MHz I²C interface supports up to eight devices on the bus. The 20MHz, bus-addressable SPI bus supports up to eight devices per chip select line. While typically the LED drive PWM signal is internally generated, both drivers also accept an external direct PWM drive signal applied to the PWM input that sets the PWM duty and the frequency of the LEDs drive signal. Both devices also feature phase spreading when external PWM direct drive is used. With phase spreading enabled, a progressive 1/16 phase delay per string helps reduce both the transient load on the LED power supplies and the power supply input capacitor size requirements.

The PWM frequency of the drivers is either synchronized to an external signal applied to PHI, generated from the internal oscillator for standalone applications, or set directly by a signal at the PWM input. Typically the VSYNC signal from the video system is used for the PHI input. A frequency multiplier (1x to 32x) processes this signal for use by the PWM engine. The on time of each string is individually programmed via the device registers, providing a peak resolution of 12 bits when using the on-chip PWM generator. The actual resolution of the PWM frequency depends on the ratio of the GSC frequency (typically provided by a systems HSYNC signal, but can be internally generated) to the PHI frequency because the on time of a string is programmed as a 12-bit count of the number of GSC clock cycles. This count can be further scaled by an 8-bit global intensity value, when enabled. The GSC clock is also used to precisely set each string's phase delay so that it is synchronized to its physical position relative to the video frame.

The Efficiency Optimizers control a wide range of different external DC-DC and AC-DC converter architectures. Multiple drivers in a system communicate in real time among themselves to select an optimized operating voltage for the LEDs. This allows design of the power supply for the worst case forward voltage (V_f) of the LEDs without concern about excessive power dissipation issues. During the start-up sequence, the MSL2160/1 automatically reduces the power supply voltage to the minimum voltage required to keep the LEDs in current regulation. The devices can be configured to periodically perform this optimization to compensate for changes in LED forward voltage, and to assure continued optimum power savings.



Internal Regulators and Enable Input

The MSL2160/1 includes two internal linear regulators that provide VCC (5V) and VDD (2.5V) for internal circuitry. VIN (12V nominal) supplies the VCC and VDD regulators. Bypass VIN to GND with a 10µF capacitor close to the device. Bypass VCC to GND with a 4.7µF capacitor close to the device. Bypass VDD to GND with a 4.7µF capacitor close to the device.

The MSL2160/1 enables input, EN, enables the device. Drive EN low to enter low power operation, which lowers quiescent current draw to less than 20µA. With EN low, the serial interface is ignored, the Efficiency Optimizer is disabled, and all strings are turned off. Drive EN high to turn on the device. When EN is driven high, the contents of the EEPROM are boot loaded into the control registers, simulating a cold start up, and all bits in the fault registers are cleared to 0.

Setting the Maximum LED String Current with a Source Resistor

The maximum string current, I_{LEDn} , for each string is set by a shunt resistor connected to ground from the source terminal of the string drive MOSFET. The feedback threshold is 500mV. Determine the resistor value using:

$$R_s = \frac{0.5}{I_{LED}}$$

where I_{LED} is in amperes and R_s is in ohms.

For example, a full-scale LED current of 100mA returns $R_s = 5\Omega$. The current for all LED strings is reduced from the full-scale value with 8-bit resolution using ISTR, the string current control register 0x31.

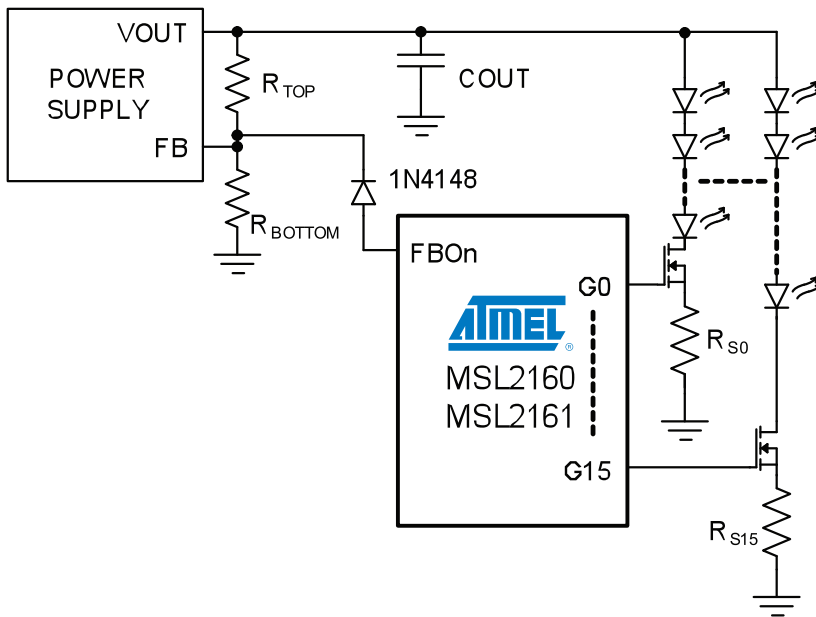

Figure 5. FBO connects to the Power Supply Voltage Divider Through a Diode.

Atmel LED Drivers-MSL2160/MSL2161

16-string, White and RGB LED Drivers with Adaptive Configuration, EEPROM, and SPI/I²C/SMBus Serial Interface

Connecting the Efficiency Optimizer to an LED String Power Supply and Selecting Resistors

The MSL2160/1 are designed to control external LED string power supplies that use voltage dividers (R_{TOP} and R_{BOTTOM} in Figure 5) to set the output voltage, and whose regulation feedback voltage is not more than 3.5V. The Efficiency Optimizer improves power efficiency by injecting a current of between 0 and 255 μ A into the voltage dividers of the external power supplies, dynamically adjusting their outputs to the minimum voltage required by the LED strings. To select the resistors, first determine $V_{OUT(MIN)}$ and $V_{OUT(MAX)}$, the minimum and maximum string supply voltage limits, using:

$$V_{OUT(MIN)} = (V_{f(MIN)} * [\#ofLEDs]) + 0.5 \quad \text{and}$$

$$V_{OUT(MAX)} = (V_{f(MAX)} * [\#ofLEDs]) + 0.5,$$

where $V_{f(MIN)}$ and $V_{f(MAX)}$ are the LED minimum and maximum forward voltage drops at the peak current set by R_S (page 12). For example, if the LED data are $V_{f(MIN)} = 3.5V$ and $V_{f(MAX)} = 3.8V$, and ten LEDs are used in a string, then the total minimum and maximum voltage drops across a string are 35V and 38V, respectively. Adding an allowance of 0.5V for the string drive MOSFET headroom brings $V_{OUT(MIN)}$ to 35.5V and $V_{OUT(MAX)}$ to 38.5V. Then, determine R_{TOP} using:

$$R_{TOP} = \frac{V_{OUT(MAX)} - V_{OUT(MIN)}}{I_{FBOn(MAX)}}$$

where $I_{FBOn(MAX)}$ is the 255 μ A maximum output current of the efficiency optimizer outputs FBO_n. Finally, determine R_{BOTTOM} using:

$$R_{BOTTOM} = R_{TOP} * \frac{V_{FB}}{V_{OUT(MAX)} - V_{FB}}$$

where V_{FB} is the regulation feedback voltage of the power supply. Place a diode (1N4148 or similar) between FBO_n and the supply's feedback node to protect the MSL2160/1 against current flow into FBO_n. Assign all strings powered by a common supply to the proper FBO output using string set registers 0x40 - 0x5F.

Once configured, determine the change in power supply output voltage in response to a change in FBO output current using:

$$\Delta V_{OUT} = \Delta I_{FBO} * R_{TOP}$$

Direct PWM Control of the LED Strings

An external PWM signal applied to the PWM input allows direct PWM control over the strings when bits PWMEN and PWMDIRECT (bits D0 and D1 in PWM control register 0x2D) are set to 1. This configuration bypasses PHI and GSC, but allows LED string phase delay via the phase delay enable bit, PHADLYEN (bit D0 of register 0x2E). With phase delay enabled, a progressive delay of 1/16 the PWM frame is calculated and applied successively to each string drive signal.

The PWM input can also be configured as a gate for the output of the PWM engine using PWM global enable (bit D2 of the PWM control register 0x2D).



Register Map and the EEPROM

Register Map Summary

Control the MSL2160/1 using the registers in the range 0x00 - 0xBF (Table 4). Two additional registers, 0xC0 and 0xC1, allow access to, and programming of, the EEPROM. The power-up default values for all control registers are stored within the on-chip EEPROM, and any of these EEPROM values may be changed through the serial interface.

Table 4. Atmel LED Drivers-MSL2160/1 Register Map

ADDRESS AND REGISTER NAME		FUNCTION	REGISTER DATA							
			D7	D6	D5	D4	D3	D2	D1	D0
0x00	STRINGEN0	LED string enables	STR7EN	STR6EN	STR5EN	STR4EN	STR3EN	STR2EN	STR1EN	STR0EN
0x01	STRINGEN1		STR15EN	STR14EN	STR13EN	STR12EN	STR11EN	STR10EN	STR9EN	STR8EN
0x02	CONFIG	Configuration	SLEEP	-	-	-	FLDBKEN	STRSCDLY[2:0]		
0x03	FLTEN	Fault enable	-	-	I ² CTOEN	PHIMAXFEN	GSCMAXFEN	STRSCFEN	STROCFEN	FBOOCFEN
0x04	FLTMASK0	String fault mask	FEN7	FEN6	FEN5	FEN4	FEN3	FEN2	FEN1	FEN0
0x05	FLTMASK1		FEN15	FEN14	FEN13	FEN12	FEN11	FEN10	FEN9	FEN8
0x06	FLTSTATUS*	Fault status	FLTBDRV	-	-	PHIMAXFLT	GSCMAXFLT	STRSCFLT	STROCFLT	FBOOCFLT
0x07	OCSTAT0*	String open circuit fault status	OC7	OC6	OC5	OC4	OC3	OC2	OC1	OC0
0x08	OCSTAT1*		OC15	OC14	OC13	OC12	OC11	OC10	OC9	OC8
0x09	SCSTAT0*	String short circuit fault status	SC7	SC6	SC5	SC4	SC3	SC2	SC1	SC0
0x0A	SCSTAT1*		SC15	SC14	SC13	SC12	SC11	SC10	SC9	SC8
0x0B - 0x0E			UNUSED							
0x0F	OSCFREQ	Oscillator frequency	-	-	-	-	-	OSCFREQ[2:0]		
0x10	FBOCTRL0	Efficiency optimizer control	HDRMSTEP[1:0]		RECALDLY[1:0]		SETTLE[1:0]		IERRCONF[1:0]	
0x11	FBOCTRL1		INCRSTEP[1:0]		DECRSTEP[1:0]		INITPWM	ACAL100	ACALEN	ICHKDIS
0x12	FBOCTRL2		-	-	-	-	FBO3OCEN	FBO2OCEN	FBO1OCEN	FBOEN
0x13	FBODAC1*	Efficiency optimizer DAC readback	FBODAC1[7:0]							
0x14	FBODAC2*		FBODAC2[7:0]							
0x15	FBODAC3*		FBODAC3[7:0]							
0x16	FBOSTATUS*	Efficiency optimizer status	FBO3OC	FBO2OC	FBO1OC	FBO3ACT	FBO2ACT	FBO1ACT	FBOCAL	FBOINITCAL
0x17- 0x1F			UNUSED							
0x20	GSCCTRL	GSC processing control	GSCCHK-SEL	-	-	-	GSCMAXEN	GSCPOL	GSCPHI-SYNCEN	GSCINTEN
0x21	GSCCNTR	Internal clock counter for GSC	GSCCNTR[7:0]							
0x22			GSCCNTR[15:8]							
0x23	GSCMUL	GSC multiplier	-	-	-	GSCMUL[4:0]				
0x24	GSCDIV	GSC divider	GSCDIV[7:0]							

Atmel LED Drivers-MSL2160/MSL2161

16-string, White and RGB LED Drivers with Adaptive Configuration, EEPROM, and SPI/I²C/SMBus Serial Interface

ADDRESS AND REGISTER NAME		FUNCTION	REGISTER DATA							
			D7	D6	D5	D4	D3	D2	D1	D0
0x25	GSCMAX	Max oscillator cycles between GSC pulses	GSCMAX[7:0]							
0x26			GSCMAX[15:8]							
0x27	PHICTRL	PHI processing control	PHICHECKSEL	-	-	-	-	PHIMAXEN	PHIPOL	PHIINTEN
0x28	PHICNTR	Internal clock counter for PHI	PHICNTR[7:0]							
0x29			PHICNTR[15:8]							
0x2A	PHIMUL	PHI multiplier	-	-	-	PHIMUL[4:0]				
0x2B	PHIMAX	Max GSC cycles between PHI pulses	PHIMAX[7:0]							
0x2C			PHIMAX[15:8]							
0x2D	PWMCTRL0	PWM control	GINT+1EN	GINTEN	ALTEN	OVRFLOZEN	OVRFLOEN	PWM-GLBLEN	PWMDIRECT	PWMEN
0x2E	PWMCTRL1		-	-	-	-	EXTALTEN	PHOVR-FLOZEN	PHOVR-FLOEN	PHADLYEN
0x2F	GINT	Global PWM scaling	GINT[7:0]							
0x30	ALTGINT	Alternate global PWM scaling	ALTGINT[7:0]							
0x31	ISTR	8-bit global string current scaling	ISTR[7:0]							
0x32	PWMSTATUS*	PWM and counter status	PHIMAXERRCNT[2:0]			PHIMAX1FLT	PHISIGFLT	GSCSIGFLT	PHICNTRFLT	GINT-MULERR
0x33	PHIPCNT*	PHI pulse counter and status	PHICNTR-MAX	-	-	PHIPCNT[4:0]				
0x34	GSCPCNT*	GSC pulse counter	GSCPULSECNTR[7:0]							
0x35			GSCPULSECNTR[12:8]							
0x36 - 0x3F			UNUSED							
0x40	STR0SET	Phase delay and EO assignment for string 0	PHDLY0[7:0]							
0x41			FBOSET0[1:0]	-	-	PHDLY[11:8]				
↓	↓	↓	↓							
0x5E	STR15SET	Phase delay and EO assignment for string 15	PHDLY15[7:0]							
0x5F			FBOSET15[1:0]	-	-	PHDLY[11:8]				
0x60	PWM0	PWM setting for string 0	PWM0[7:0]							
0x61			-	-	-	-	PWM0[11:8]			



ADDRESS AND REGISTER NAME		FUNCTION	REGISTER DATA						
			D7	D6	D5	D4	D3	D2	D1
↓	↓	↓	↓						
0x7E	PWM15	PWM setting for string 14	PWM15[7:0]						
0x7F			-	-	-	-	PWM15[11:8]		
0x80	ALTSTR0SET	Alternate phase delay for string 0	ALTPHDLY0[7:0]						
0x81			-	-	-	-	ALTPHDLY[11:8]		
↓	↓	↓	↓						
0x9E	ALTSTR15SET	Alternate phase delay for string 15	ALTPHDLY15[7:0]						
0x9F			-	-	-	-	ALTPHDLY[11:8]		
0xA0	ALTPWM0	Alternate PWM setting for string 0	ALTPWM0[7:0]						
0xA1			-	-	-	-	ALTPWM0[11:8]		
↓	↓	↓	↓						
0xBE	ALTPWM15	Alternate PWM setting for string 15	ALTPWM15[7:0]						
0xBF			-	-	-	-	ALTPWM15[11:8]		
0xC0	E2ADDR	EEPROM read/write access	E2ADDR[6:0]						
0xC1	E2CTRLSTA		E2BUSY	BLDACT	E2ERR	-	-	RWCTRL[2:0]	

* Read-only registers

Atmel LED Drivers-MSL2160/MSL2161

16-string, White and RGB LED Drivers with Adaptive Configuration, EEPROM, and SPI/I²C/SMBus Serial Interface

Register Power-up Defaults

Register power-up default values are shown in Table 5.

Table 5. Atmel LED Drivers-MSL2160/1 Register Power-up Defaults

REGISTER NAME AND ADDRESS		POWER-UP CONDITION REGISTERS INITIALIZED FROM EEPROM	REGISTER DATA								
			D7	D6	D5	D4	D3	D2	D1	D0	HEX
0x00	STRINGEN0	All LED string drive outputs enabled	1	1	1	1	1	1	1	1	FF
0x01	STRINGEN1		1	1	1	1	1	1	1	1	FF
0x02	CONFIG	String short circuit confirmation delay = 256μs String current fold-back enabled Device is not asleep	0	0	0	0	1	1	0	1	0D
0x03	FLTEN	FBO open circuit fault detect globally enabled String open circuit fault detect globally enabled LED short circuit fault detect globally enabled GSC max fault detect globally disabled PHI max fault detect globally disabled I ² C timeout enabled	0	0	1	0	0	1	1	1	27
0x04	FLTMASK0	Fault detection individually enabled for all strings	1	1	1	1	1	1	1	1	FF
0x05	FLTMASK1		1	1	1	1	1	1	1	1	FF
0x0F	OSCFREQ	f _{osc} = 20MHz	0	0	0	0	0	1	0	0	04
0x10	FBOCTRL0	Current sink error confirmation delay = 2μs FBO power supply settling time allowance = 4ms	0	1	0	0	1	0	0	1	49
0x11	FBOCTRL1	Efficiency Optimizer auto-recalibration delay = 1s Efficiency Optimizer headroom steps = 3 MOSFET current sink error detection enabled	0	0	0	1	1	0	1	0	1A
0x12	FBOCTRL2	Efficiency Optimizer auto-recalibration enabled PWM settings used during auto-recalibration PWM settings used during initial calibration Efficiency Optimizer correction step size = 1 LSB (1μA) Efficiency Optimizer initial calibration step size = 1 LSB (1μA) FBO outputs globally enabled Open circuit detection enabled for all three FBO outputs	0	0	0	0	1	1	1	1	0F
0x20	GSCCTRL	External signal at GSC is selected for input to the PWM engine GSC not internally synchronized to PHI PWM drive synchronized to falling edge of external GSC GSC maximum count fault detect is disabled Although disabled, GSC max fault monitors f _{pGSC}	0	0	0	0	0	0	0	0	00
0x21	GSCCNTR	Although disabled, internal GSC frequency	0	1	0	1	0	0	0	0	50
0x22		f _{GGEN} = 20MHz / (80 + 1) = 246kHz	0	0	0	0	0	0	0	0	00
0x23	GSCMUL	GSC multiplexer output is multiplied by 4 (register setting + 1)	0	0	0	0	0	0	1	1	03
0x24	GSCDIV	GSC multiplier output is divided by 1 (register setting + 1)	0	0	0	0	0	0	0	0	00
0x25	GSCMAX	Although disabled, GSC max count is set to 174 clock cycles	1	0	1	0	1	1	1	0	AE
0x26			0	0	0	0	0	0	0	0	00



Table 5. Atmel LED Drivers-MSL2160/1 Register Power-up Defaults

REGISTER NAME AND ADDRESS		POWER-UP CONDITION REGISTERS INITIALIZED FROM EEPROM	REGISTER DATA							HEX	
			D7	D6	D5	D4	D3	D2	D1		D0
0x27	PHICTRL	External signal at PHI selected for input to PWM engine PWM engine is synchronized to the falling edge of PHI PHI maximum count fault detect is disabled Although disabled, PHI max count monitors f_{pPHI}	0	0	0	0	0	0	0	0	00
0x28	PHICNTR	Although disabled, internal PHI frequency $f_{PGEN} = 20\text{MHz} / (8 * (10416 + 1)) = 240\text{Hz}$	1	0	1	1	0	0	0	0	B0
0x29			0	0	1	0	1	0	0	0	28
0x2A	PHIMUL	PHI multiplier = 1 (register setting + 1)	0	0	0	0	0	0	0	0	00
0x2B	PHIMAX	Although disabled, PHI maximum count = 4148	0	0	1	1	0	1	0	0	34
0x2C			0	0	0	1	0	0	0	0	10
0x2D	PWMCTRL0	PWM operation enabled Individual LED string drive pulse widths internally determined PWM input does not gate the output of the PWM engine String on times allowed to extend beyond end of PWM frame String on times allowed to extend into frame zero	1	0	0	1	1	0	0	1	99
0x2E	PWMCTRL1	Alternate timing not used Global intensity (GINT) disabled Although disabled, (GINT + 1) is provided to the PWM engine String drive phasing enabled Delayed string turn on beginning after PWM frame allowed Delayed turn on occurring in frame zero allowed Alternate timing not selected by PWM input state	0	0	0	0	0	1	1	1	07
0x2F	GINT	Although disabled, global intensity set to $(127 + 1) / 256 = 50\%$ (1 added in numerator because bit D7 of 0x2D = 1)	0	1	1	1	1	1	1	1	7F
0x30	ALTGINT	Although disabled, alternate global intensity set to $(95 + 1) / 256 = 37.5\%$ (1 added in numerator because bit D7 of 0x2D = 1)	0	1	0	1	1	1	1	1	5F
0x31	ISTR	Strings current scaled to 50% of R_{Sn} setting	0	1	1	1	1	1	1	1	7F
0x40	STR0SET	All strings set to zero phase delay Strings assigned as follows: FBO1: All strings FBO2: None FBO3: None	0	0	0	0	0	0	0	0	00
0x41			0	1	0	0	0	0	0	0	40
↓	↓		↓								
0x5E	STR15SET		0	0	0	0	0	0	0	0	00
0x5F			0	1	0	0	0	0	0	0	40
0x60	PWM0		0	0	0	0	0	0	0	0	00
0x61			0	0	0	0	0	0	1	0	02
↓	↓		↓								
0x7E	PWM15	All strings have PWM $t_{ON} = 512$ GSC cycles	0	0	0	0	0	0	0	0	00
0x7F			0	0	0	0	0	0	1	0	02

Atmel LED Drivers-MSL2160/MSL2161

16-string, White and RGB LED Drivers with Adaptive Configuration, EEPROM, and SPI/I²C/SMBus Serial Interface

REGISTER NAME AND ADDRESS		POWER-UP CONDITION REGISTERS INITIALIZED FROM EEPROM	REGISTER DATA								
			D7	D6	D5	D4	D3	D2	D1	D0	HEX
0x80	ALTSTR0SET	All strings set to zero phase delay	0	0	0	0	0	0	0	0	00
0x81			0	0	0	0	0	0	0	0	40
↓	↓		↓								
0x9E	ALTSTR15SET		0	0	0	0	0	0	0	0	00
0x9F			0	0	0	0	0	0	0	0	00
0xA0	ALTPWM0		All strings set with alternate PWM $t_{ON} = 512$ GSC cycles	0	0	0	0	0	0	0	0
0xA1		0		0	0	0	0	0	1	0	02
↓	↓	↓									
0xBE	ALTPWM15	0		0	0	0	0	0	0	0	00
0xBF		0		0	0	0	0	0	1	0	02
REGISTERS WITH FIXED INITIAL VALUES											
0xC0	E2ADDR	EEPROM 7 bit address = 0x00	0	0	0	0	0	0	0	0	00
0xC1	E2CTRLSTA	EEPROM read/write disabled	0	0	0	0	0	0	0	0	00

* Read-only registers

**Atmel Corporation**

2325 Orchard Parkway
San Jose, CA 95131
USA

Tel: (+1)(408) 441-0311

Fax: (+1)(408) 487-2600

www.atmel.com

Atmel Asia Limited

Unit 01-5 & 16, 19F
BEA Tower, Millennium City 5
418 Kwun Tong Road
Kwun Tong, Kowloon
HONG KONG

Tel: (+852) 2245-6100

Fax: (+852) 2722-1369

Atmel Munich GmbH

Business Campus
Parking 4
D-85748 Garching b. Munich
GERMANY

Tel: (+49) 89-31970-0

Fax: (+49) 89-3194621

Atmel Japan

9F, Tonetsu Shinkawa Bldg.
1-24-8 Shinkawa
Chuo-ku, Tokyo 104-0033
JAPAN

Tel: (+81)(3) 3523-3551

Fax: (+81)(3) 3523-7581

© 2011 Atmel Corporation. All rights reserved. / Rev.: MEM-MSL2160/61DB1-E-US_06-11

Atmel®, logo and combinations thereof, and others are registered trademarks or trademarks of Atmel Corporation or its subsidiaries. Other terms and product names may be trademarks of others.

Disclaimer: The information in this document is provided in connection with Atmel products. No license, express or implied, by estoppel or otherwise, to any intellectual property right is granted by this document or in connection with the sale of Atmel products. EXCEPT AS SET FORTH IN THE ATMEL TERMS AND CONDITIONS OF SALES LOCATED ON THE ATMEL WEBSITE, ATMEL ASSUMES NO LIABILITY WHATSOEVER AND DISCLAIMS ANY EXPRESS, IMPLIED OR STATUTORY WARRANTY RELATING TO ITS PRODUCTS INCLUDING, BUT NOT LIMITED TO, THE IMPLIED WARRANTY OF MERCHANTABILITY, FITNESS FOR A PARTICULAR PURPOSE, OR NON-INFRINGEMENT. IN NO EVENT SHALL ATMEL BE LIABLE FOR ANY DIRECT, INDIRECT, CONSEQUENTIAL, PUNITIVE, SPECIAL OR INCIDENTAL DAMAGES (INCLUDING, WITHOUT LIMITATION, DAMAGES FOR LOSS AND PROFITS, BUSINESS INTERRUPTION, OR LOSS OF INFORMATION) ARISING OUT OF THE USE OR INABILITY TO USE THIS DOCUMENT, EVEN IF ATMEL HAS BEEN ADVISED OF THE POSSIBILITY OF SUCH DAMAGES. Atmel makes no representations or warranties with respect to the accuracy or completeness of the contents of this document and reserves the right to make changes to specifications and products descriptions at any time without notice. Atmel does not make any commitment to update the information contained herein. Unless specifically provided otherwise, Atmel products are not suitable for, and shall not be used in, automotive applications. Atmel products are not intended, authorized, or warranted for use as components in applications intended to support or sustain life.