

**REVISIONS**

LTR	DESCRIPTION	DATE (YR-MO-DA)	APPROVED

REV																				
SHEET																				
REV																				
SHEET																				

REV STATUS OF SHEETS	REV																			
	SHEET	1	2	3	4	5	6	7	8	9	10	11	12	13						

PMIC N/A	PREPARED BY Dan Wonnell	DEFENSE ELECTRONICS SUPPLY CENTER DAYTON, OHIO 45444			
<p align="center"><b>STANDARD MICROCIRCUIT DRAWING</b></p> <p>THIS DRAWING IS AVAILABLE FOR USE BY ALL DEPARTMENTS AND AGENCIES OF THE DEPARTMENT OF DEFENSE</p> <p>AMSC N/A</p>	CHECKED BY Sandra Rooney	MICROCIRCUIT, LINEAR, WIDEBAND/VIDEO MULTIPLEXER, MONOLITHIC SILICON			
	APPROVED BY Michael A. Frye				
	DRAWING APPROVAL DATE 94-12-06				
	REVISION LEVEL	SIZE <b>A</b>	CAGE CODE <b>67268</b>	<b>5962-90602</b>	
		SHEET	1	OF	13

DESC FORM 193  
JUL 94

DISTRIBUTION STATEMENT A. Approved for public release; distribution is unlimited.

5962-E437-93

■ 9004708 0004127 2T4 ■

1. SCOPE

1.1 Scope. This drawing forms a part of a one part - one part number documentation system (see 6.6 herein). Two product assurance classes consisting of military high reliability (device classes Q and M) and space application (device class V), and a choice of case outlines and lead finishes are available and are reflected in the Part or Identifying Number (PIN). Device class M microcircuits represent non-JAN class B microcircuits in accordance with 1.2.1 of MIL-STD-883, "Provisions for the use of MIL-STD-883 in conjunction with compliant non-JAN devices". When available, a choice of Radiation Hardness Assurance (RHA) levels are reflected in the PIN.

1.2 PIN. The PIN shall be as shown in the following example:

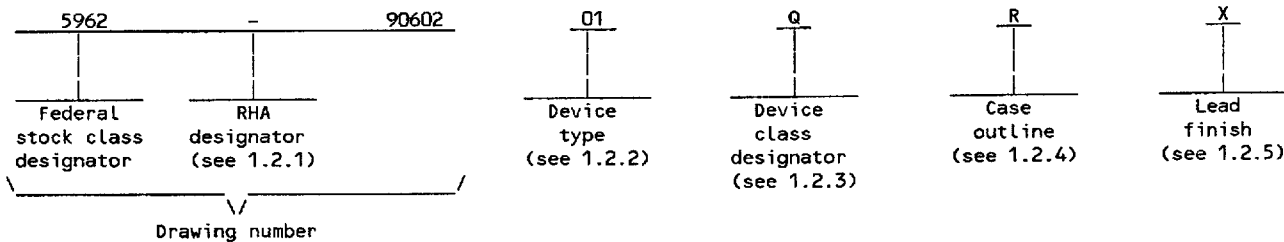

1.2.1 RHA designator. Device class M RHA marked devices shall meet the MIL-I-38535 appendix A specified RHA levels and shall be marked with the appropriate RHA designator. Device classes Q and V RHA marked devices shall meet the MIL-I-38535 specified RHA levels and shall be marked with the appropriate RHA designator. A dash (-) indicates a non-RHA device.

1.2.2 Device type(s). The device type(s) shall identify the circuit function as follows:

<u>Device type</u>	<u>Generic number</u>	<u>Circuit function</u>
01	DG534AA	4-channel wideband/video multiplexer

1.2.3 Device class designator. The device class designator shall be a single letter identifying the product assurance level as follows:

<u>Device class</u>	<u>Device requirements documentation</u>
M	Vendor self-certification to the requirements for non-JAN class B microcircuits in accordance with 1.2.1 of MIL-STD-883
Q or V	Certification and qualification to MIL-I-38535

1.2.4 Case outline(s). The case outline(s) shall be as designated in MIL-STD-1835 and as follows:

<u>Outline letter</u>	<u>Descriptive designator</u>	<u>Terminals</u>	<u>Package style</u>
R	GDIP1-T20 or CDIP2-T20	20	dual-in-line

1.2.5 Lead finish. The lead finish shall be as specified in MIL-STD-883 (see 3.1 herein) for class M or MIL-I-38535 for classes Q and V. Finish letter "X" shall not be marked on the microcircuit or its packaging. The "X" designation is for use in specifications when lead finishes A, B, and C are considered acceptable and interchangeable without preference.

STANDARD MICROCIRCUIT DRAWING DEFENSE ELECTRONICS SUPPLY CENTER DAYTON, OHIO 45444	SIZE A		5962-90602
		REVISION LEVEL	SHEET 2

DESC FORM 193A  
 JUL 94

9004708 0004128 130

1.3 Absolute maximum ratings. 1/

V+ to V-	.....	-0.3 V dc to 21 V dc
V+ to GND	.....	-0.3 V dc to 21 V dc
V- to GND	.....	-10 V dc to 0.3 V dc
Digital inputs	.....	(V-) - 0.32 V dc to (V <sub>L</sub> -) + 0.3 V dc or 20 mA, whichever occurs first.
Digital inputs (V <sub>S</sub> , V <sub>D</sub> )	.....	(V-) - 0.32 V dc to (V-) + 21 V dc or 20 mA, whichever occurs first.
Current (continuous, any terminal)	.....	20 mA
Peak current, S or D (pulsed at 1 ms, 10% duty cycle max.)	.....	40 mA
Power dissipation (P <sub>D</sub> ) 2/	.....	1200 mw
Storage temperature range	.....	-65°C to +150°C
Junction temperature (T <sub>J</sub> )	.....	+150°C
Lead temperature (soldering, 10 seconds)	.....	+300°C

1.4 Recommended operating conditions.

Positive supply voltage (V+)	.....	+15 V dc
Negative supply voltage (V-)	.....	-3 V dc
Logic supply voltage (V <sub>L</sub> )	.....	+5 V dc
Ambient operating temperature range	.....	-55°C to +125°C

2. APPLICABLE DOCUMENTS

2.1 Government specification, standards, bulletin, and handbook. Unless otherwise specified, the following specification, standards, bulletin, and handbook of the issue listed in that issue of the Department of Defense Index of Specifications and Standards specified in the solicitation, form a part of this drawing to the extent specified herein.

SPECIFICATION

MILITARY

MIL-I-38535 - Integrated Circuits, Manufacturing, General Specification for.

STANDARDS

MILITARY

MIL-STD-883 - Test Methods and Procedures for Microelectronics.  
 MIL-STD-973 - Configuration Management.  
 MIL-STD-1835 - Microcircuit Case Outlines.

BULLETIN

MILITARY

MIL-BUL-103 - List of Standardized Military Drawings (SMD's).

HANDBOOK

MILITARY

MIL-HDBK-780 - Standardized Military Drawings.

(Copies of the specification, standards, bulletin, and handbook required by manufacturers in connection with specific acquisition functions should be obtained from the contracting activity or as directed by the contracting activity.)

1/ Stresses above the absolute maximum rating may cause permanent damage to the device. Extended operation at the maximum levels may degrade performance and affect reliability.  
 2/ Derate linearly at 16 mW/°C above T<sub>A</sub> = +75°C.

STANDARD MICROCIRCUIT DRAWING DEFENSE ELECTRONICS SUPPLY CENTER DAYTON, OHIO 45444	SIZE A		5962-90602
		REVISION LEVEL	SHEET 3

DESC FORM 193A  
 JUL 94

9004708 0004129 077

2.2 Order of precedence. In the event of a conflict between the text of this drawing and the references cited herein, the text of this drawing shall take precedence.

### 3. REQUIREMENTS

3.1 Item requirements. The individual item requirements for device class M shall be in accordance with 1.2.1 of MIL-STD-883, "Provisions for the use of MIL-STD-883 in conjunction with compliant non-JAN devices" and as specified herein. The individual item requirements for device classes Q and V shall be in accordance with MIL-I-38535 and as specified herein or as modified in the device manufacturer's Quality Management (QM) plan. The modification in the QM plan shall not effect the form, fit, or function as described herein.

3.2 Design, construction, and physical dimensions. The design, construction, and physical dimensions shall be as specified in MIL-STD-883 (see 3.1 herein) for device class M and MIL-I-38535 for device classes Q and V and herein.

3.2.1 Case outline(s). The case outline(s) shall be in accordance with 1.2.4 herein.

3.2.2 Terminal connections. The terminal connections shall be as specified on figure 1.

3.2.3 Truth table(s). The truth table(s) shall be as specified on figure 2.

3.3 Electrical performance characteristics and postirradiation parameter limits. Unless otherwise specified herein, the electrical performance characteristics and postirradiation parameter limits are as specified in table I and shall apply over the full ambient operating temperature range.

3.4 Electrical test requirements. The electrical test requirements shall be the subgroups specified in table II. The electrical tests for each subgroup are defined in table I.

3.5 Marking. The part shall be marked with the PIN listed in 1.2 herein. Marking for device class M shall be in accordance with MIL-STD-883 (see 3.1 herein). In addition, the manufacturer's PIN may also be marked as listed in MIL-BUL-103. Marking for device classes Q and V shall be in accordance with MIL-I-38535.

3.5.1 Certification/compliance mark. The compliance mark for device class M shall be a "C" as required in MIL-STD-883 (see 3.1 herein). The certification mark for device classes Q and V shall be a "QML" or "Q" as required in MIL-I-38535.

3.6 Certificate of compliance. For device class M, a certificate of compliance shall be required from a manufacturer in order to be listed as an approved source of supply in MIL-BUL-103 (see 6.7.2 herein). For device classes Q and V, a certificate of compliance shall be required from a QML-38535 listed manufacturer in order to supply to the requirements of this drawing (see 6.7.1 herein). The certificate of compliance submitted to DESC-EC prior to listing as an approved source of supply for this drawing shall affirm that the manufacturer's product meets, for device class M, the requirements of MIL-STD-883 (see 3.1 herein), or for device classes Q and V, the requirements of MIL-I-38535 and the requirements herein.

3.7 Certificate of conformance. A certificate of conformance as required for device class M in MIL-STD-883 (see 3.1 herein) or for device classes Q and V in MIL-I-38535 shall be provided with each lot of microcircuits delivered to this drawing.

3.8 Notification of change for device class M. For device class M, notification to DESC-EC of change of product (see 6.2 herein) involving devices acquired to this drawing is required for any change as defined in MIL-STD-973.

3.9 Verification and review for device class M. For device class M, DESC, DESC's agent, and the acquiring activity retain the option to review the manufacturer's facility and applicable required documentation. Offshore documentation shall be made available onshore at the option of the reviewer.

3.10 Microcircuit group assignment for device class M. Device class M devices covered by this drawing shall be in microcircuit group number 82 (see MIL-I-38535, appendix A).

### 4. QUALITY ASSURANCE PROVISIONS

4.1 Sampling and inspection. For device class M, sampling and inspection procedures shall be in accordance with MIL-STD-883 (see 3.1 herein). For device classes Q and V, sampling and inspection procedures shall be in accordance with MIL-I-38535 or as modified in the device manufacturer's Quality Management (QM) plan. The modification in the QM plan shall not effect the form, fit, or function as described herein.

STANDARD MICROCIRCUIT DRAWING DEFENSE ELECTRONICS SUPPLY CENTER DAYTON, OHIO 45444	SIZE A		5962-90602
		REVISION LEVEL	SHEET 4

DESC FORM 193A  
JUL 94

9004708 0004130 899

TABLE I. Electrical performance characteristics.

Test	Symbol	Conditions -55°C ≤ T <sub>A</sub> ≤ +125°C V <sub>t</sub> = 15V, V <sub>-</sub> = -3 V, V <sub>L</sub> = 5 V WR = 0.8 V, RS, EN = 2 V unless otherwise specified	Group A subgroups	Device type	Limits		Unit
					Min	Max	
Drain-source ON resistance	Γ <sub>DS(ON)</sub>	I <sub>S</sub> = -10 mA, V <sub>S</sub> = 0 V V <sub>AIL</sub> = 0.8 V, V <sub>AIH</sub> = 2 V Sequence each switch on	1, 3	01		90	Ω
			2			120	
Resistance match between channels	Δ Γ <sub>DS(ON)</sub>	I <sub>S</sub> = -10 mA, V <sub>S</sub> = 0 V V <sub>AIL</sub> = 0.8 V, V <sub>AIH</sub> = 2 V Sequence each switch on	1	01		9	Ω
Source OFF leakage current	I <sub>S(OFF)</sub>	V <sub>S</sub> = 8 V, V <sub>D</sub> = 0 V EN = 0.8 V	1	01		5	nA
			2, 3			50	
Drain OFF leakage current	I <sub>D(OFF)</sub>	V <sub>S</sub> = 0 V, V <sub>D</sub> = 8 V EN = 0.8 V	1	01		20	nA
			2, 3			500	
Drain ON leakage current	I <sub>D(ON)</sub> <sup>+</sup> I <sub>S(ON)</sub>	V <sub>S</sub> = V <sub>D</sub> = 8 V	1	01		20	nA
			2, 3			1000	
Address input current	I <sub>AI</sub>	V <sub>AI</sub> = 0 V, 2 V, 5 V	1, 3	01		1	μA
			2			10	
Multiplexer switching time	t <sub>TRANS</sub>	R <sub>L</sub> = 1 kΩ, C <sub>L</sub> = 45 pF, see figure 3	9, 11	01		300	ns
			10			500	
Break-before-make interval	t <sub>OPEN</sub>	R <sub>L</sub> = 1 kΩ, C <sub>L</sub> = 45 pF	9, 10, 11	01	25		ns
EN, $\overline{\text{WR}}$ , turn ON time	t <sub>ON</sub>	R <sub>L</sub> = 1 kΩ, C <sub>L</sub> = 45 pF, see figure 3	9, 11	01		300	ns
			10			500	
EN, turn OFF time	t <sub>OFF</sub>	R <sub>L</sub> = 1 kΩ, C <sub>L</sub> = 45 pF, see figure 3	9, 11	01		175	ns
			10			300	
Positive supply current	I <sub>t</sub>	Any one channel selected with address inputs at GND or +5 V.	1, 2	01		2	mA
			3			5	
Negative supply current	I <sub>-</sub>	Any one channel selected with address inputs at GND or +5 V.	1, 2	01	-1.8		mA
			3			-2.0	
Logic supply current	I <sub>L</sub>		1, 2, 3	01		500	μA

STANDARD  
MICROCIRCUIT DRAWING  
DEFENSE ELECTRONICS SUPPLY CENTER  
DAYTON, OHIO 45444

SIZE  
A

5962-90602

REVISION LEVEL

SHEET

5

DESC FORM 193A

JUL 94

■ 9004708 0004131 725 ■

TABLE I. Electrical performance characteristics - continued.

Test	Symbol	Conditions -55°C ≤ T <sub>A</sub> ≤ +125°C V <sub>+</sub> = 15V, V <sub>-</sub> = -3 V, V <sub>I</sub> = 5 V WR = 0.8 V, RS, EN = 2 V unless otherwise specified	Group A subgroups	Device type	Limits		Unit
					Min	Max	
Reset to write	t <sub>RW</sub>	t <sub>RW</sub> = 50 ns, see figure 3, see 4.4.1d	7, 8	01			
WR, RS minimum pulse width	t <sub>MPW</sub>	t <sub>MPW</sub> = 200 ns, see figure 3, see 4.4.1d	7, 8	01			
A <sub>0</sub> , A <sub>1</sub> , A <sub>2</sub> , EN data valid to strobe	t <sub>DW</sub>	t <sub>DW</sub> = 100 ns, see figure 3, see 4.4.1d	7, 8	01			
A <sub>0</sub> , A <sub>1</sub> , A <sub>2</sub> , EN data valid after strobe	t <sub>WD</sub>	t <sub>WD</sub> = 50 ns, see figure 3, see 4.4.1d	7, 8	01			
Address and enable output current	I <sub>AO</sub>	V <sub>AO</sub> = 2.7 V	1, 3	01		-2.5	mA
			2			-1.6	
		V <sub>AO</sub> = 0.4 V	1, 3	01	2.5		
			2		1.6		
ON state input capacitance	C <sub>S(ON)</sub>	T <sub>A</sub> = +25°C, see 4.4.1c	4	01		45	pF
OFF state input capacitance	C <sub>S(OFF)</sub>	T <sub>A</sub> = +25°C, see 4.4.1c	4	01		5	
OFF state output capacitance	C <sub>D(OFF)</sub>	T <sub>A</sub> = +25°C, see 4.4.1c	4	01		10	
Logic input capacitance	C <sub>A</sub>	T <sub>A</sub> = +25°C, see 4.4.1c	4	01		15	
OFF isolation	V <sub>ISO</sub>	T <sub>A</sub> = +25°C, see 4.4.1e	12	01	50		dB
Crosstalk	V <sub>CT</sub>	T <sub>A</sub> = +25°C, see 4.4.1e	12	01	50		
Charge transfer error	V <sub>CTE</sub>	T <sub>A</sub> = +25°C, see 4.4.1e	12	01	-15	+15	mV

STANDARD  
MICROCIRCUIT DRAWING  
DEFENSE ELECTRONICS SUPPLY CENTER  
DAYTON, OHIO 45444

SIZE  
A

5962-90602

REVISION LEVEL

SHEET

6

DESC FORM 193A  
JUL 94

9004708 0004132 661

Device type	01
Case outline	R
Terminal number	Terminal symbol
1	GND
2	D <sub>A</sub>
3	V+
4	S <sub>A1</sub>
5	GND
6	S <sub>A2</sub>
7	$\bar{4}/2$
8	$\overline{RS}$
9	$\overline{WR}$
10	A <sub>1</sub>
11	A <sub>0</sub>
12	EN
13	$\bar{I}/O$
14	V <sub>L</sub>
15	S <sub>B2</sub>
16	GND
17	S <sub>B1</sub>
18	V-
19	D <sub>B</sub>
20	NC

FIGURE 1. Terminal connections.

<b>STANDARD MICROCIRCUIT DRAWING DEFENSE ELECTRONICS SUPPLY CENTER DAYTON, OHIO 45444</b>	<b>SIZE A</b>		<b>5962-90602</b>
		<b>REVISION LEVEL</b>	<b>SHEET 7</b>

DESC FORM 193A  
JUL 94

■ 9004708 0004133 5T8 ■

$\overline{I/O}$	A <sub>1</sub>	A <sub>0</sub>	EN	$\overline{WR}$	$\overline{RS}$	$\overline{4/2}$ <sup>1/</sup>	ON Switch
X	X	X	X	—	1	1	Maintains previous state
X	X	X	X	X	0	X	None (latches cleared)
X	X	X	0	0	1	X	None
0	0	0	1	0	1	0	S <sub>A1</sub>
0	0	1	1	0	1	0	S <sub>A2</sub>
0	1	0	1	0	1	0	S <sub>B1</sub>
0	1	1	1	0	1	0	S <sub>B2</sub>
0	X	0	1	0	1	1	S <sub>A1</sub> & S <sub>B1</sub>
0	X	1	1	0	1	1	S <sub>A2</sub> & S <sub>B2</sub>
1	<u>2/</u>			1	1	<u>3/</u>	

D<sub>A</sub> and D<sub>B</sub> may be connected externally

Latches Transparent

Logic "1": V<sub>AH</sub> ≥ 2.0 V

Logic "0": V<sub>AL</sub> ≤ 0.8 V

- 1/ D<sub>A</sub> and D<sub>B</sub> must be connected externally if single-ended operation is desired.  
 2/ With I/O high, A<sub>n</sub> and EN pins become outputs and reflect the contents of the latches.  
 3/ 4/2 can be either H or L but should not change during these operations.

FIGURE 2. Truth table.

STANDARD MICROCIRCUIT DRAWING DEFENSE ELECTRONICS SUPPLY CENTER DAYTON, OHIO 45444	SIZE A	5962-90602
	REVISION LEVEL	SHEET 8

DESC FORM 193A  
 JUL 94

9004708 0004134 434



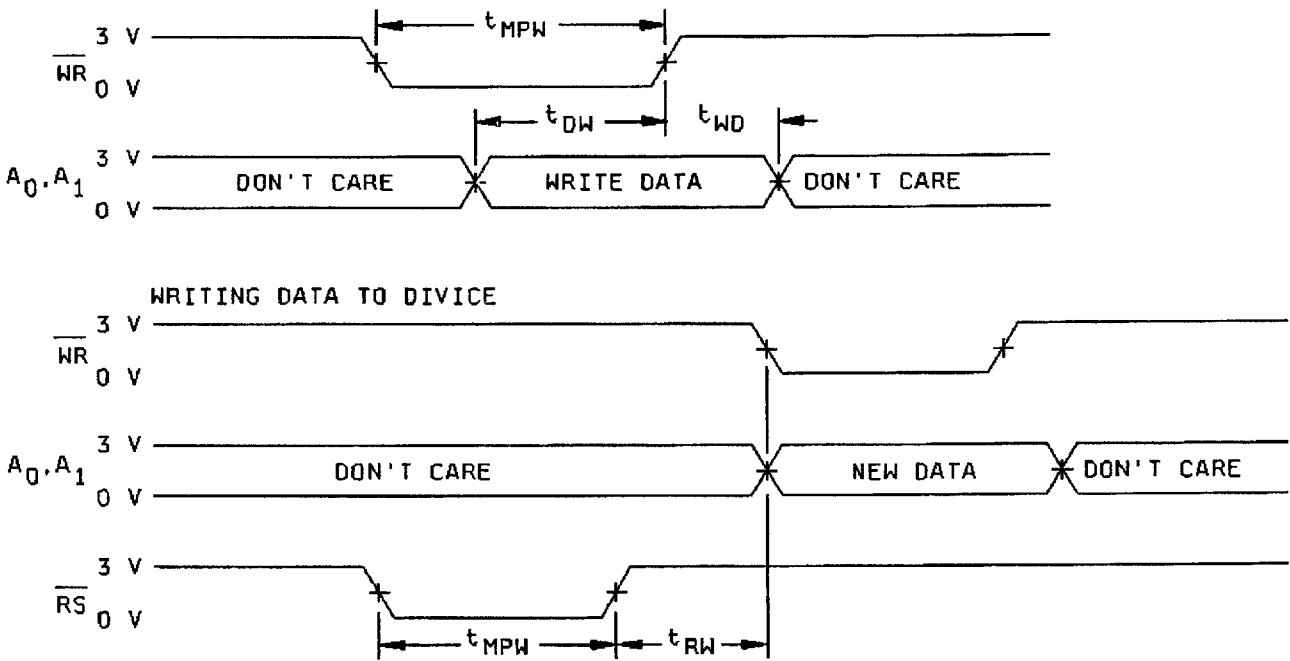
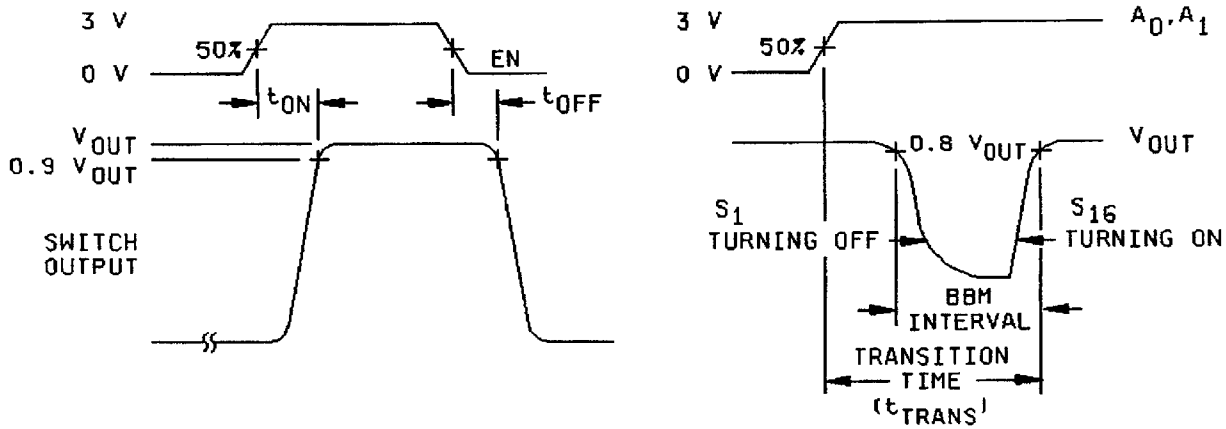

FIGURE 3. Timing waveforms.

STANDARD MICROCIRCUIT DRAWING DEFENSE ELECTRONICS SUPPLY CENTER DAYTON, OHIO 45444	SIZE A	5962-90602
	REVISION LEVEL	SHEET 9

DESC FORM 193A  
JUL 94

9004708 0004135 370

4.2 Screening. For device class M, screening shall be in accordance with method 5004 of MIL-STD-883, and shall be conducted on all devices prior to quality conformance inspection. For device classes Q and V, screening shall be in accordance with MIL-I-38535, and shall be conducted on all devices prior to qualification and technology conformance inspection.

4.2.1 Additional criteria for device class M.

a. Burn-in test, method 1015 of MIL-STD-883.

(1) Test condition A, B, C or D. The test circuit shall be maintained by the manufacturer under document revision level control and shall be made available to the preparing or acquiring activity upon request. The test circuit shall specify the inputs, outputs, biases, and power dissipation, as applicable, in accordance with the intent specified in test method 1015.

(2)  $T_A = +125^\circ\text{C}$ , minimum.

b. Interim and final electrical test parameters shall be as specified in table II herein.

4.2.2 Additional criteria for device classes Q and V.

a. The burn-in test duration, test condition and test temperature, or approved alternatives shall be as specified in the device manufacturer's QM plan in accordance with MIL-I-38535. The burn-in test circuit shall be maintained under document revision level control of the device manufacturer's Technology Review Board (TRB) in accordance with MIL-I-38535 and shall be made available to the acquiring or preparing activity upon request. The test circuit shall specify the inputs, outputs, biases, and power dissipation, as applicable, in accordance with the intent specified in test method 1015.

b. Interim and final electrical test parameters shall be as specified in table II herein.

c. Additional screening for device class V beyond the requirements of device class Q shall be as specified in appendix B of MIL-I-38535.

4.3 Qualification inspection for device classes Q and V. Qualification inspection for device classes Q and V shall be in accordance with MIL-I-38535. Inspections to be performed shall be those specified in MIL-I-38535 and herein for groups A, B, C, D, and E inspections (see 4.4.1 through 4.4.4).

4.4 Conformance inspection. Quality conformance inspection for device class M shall be in accordance with MIL-STD-883 (see 3.1 herein) and as specified herein. Inspections to be performed for device class M shall be those specified in method 5005 of MIL-STD-883 and herein for groups A, B, C, D, and E inspections (see 4.4.1 through 4.4.4). Technology conformance inspection for classes Q and V shall be in accordance with MIL-I-38535 including groups A, B, C, D, and E inspections and as specified herein except where option 2 of MIL-I-38535 permits alternate in-line control testing.

4.4.1 Group A inspection.

a. Tests shall be as specified in table II herein.

b. Subgroups 5 and 6 in table I, method 5005 of MIL-STD-883 shall be omitted.

c. Subgroup 4 (capacitance measurements) shall be measured only for the initial test and after process or design changes which may affect capacitance. Capacitance shall be measured between the designated terminal and GND at a frequency of 1 MHz. Subgroup 4 shall be performed using a sample of 5 devices with no failures allowed.

d. For device classes M, Q, and V subgroups 7 and 8 tests shall be sufficient to verify the truth table.

e. Subgroup 12 shall be measured only for the initial test and after process or design changes which may affect this parameter. Subgroup 12 shall be performed using a sample of 5 devices with no failures allowed. If not more than 1 failure is found in the first sample of 5, a second sample of 5 is permitted with no further failures allowed.

<b>STANDARD MICROCIRCUIT DRAWING DEFENSE ELECTRONICS SUPPLY CENTER DAYTON, OHIO 45444</b>	<b>SIZE A</b>		<b>5962-90602</b>
		<b>REVISION LEVEL</b>	<b>SHEET 10</b>

DESC FORM 193A  
JUL 94

■ 9004708 0004136 207 ■

TABLE II. Electrical test requirements.

Test requirements	Subgroups (in accordance with MIL-STD-883, TM 5005, table I)	Subgroups (in accordance with MIL-I-38535, table III)	
	Device class M	Device class Q	Device class V
Interim electrical parameters (see 4.2)	1	1	1
Final electrical parameters (see 4.2)	1/ 1, 2, 3, 7, 8, 9, 10, 11	1/ 1, 2, 3, 7, 8, 9, 10, 11	1/ 1, 2, 3, 7, 8, 9, 10, 11
Group A test requirements (see 4.4)	1, 2, 3, 4, 7, 8, 9, 10, 11, 12	1, 2, 3, 4, 7, 8, 9, 10, 11, 12	1, 2, 3, 4, 7, 8, 9, 10, 11, 12
Group C end-point electrical parameters (see 4.4)	1	1	1, 2, 3, 4, 7, 8, 9, 10, 11, 12
Group D end-point electrical parameters (see 4.4)	1	1	1
Group E end-point electrical parameters (see 4.4)	---	---	---

1/ PDA applies to subgroup 1.

4.4.2 Group C inspection. The group C inspection end-point electrical parameters shall be as specified in table II herein.

4.4.2.1 Additional criteria for device class M. Steady-state life test conditions, method 1005 of MIL-STD-883:

- a. Test condition A, B, C, or D. The test circuit shall be maintained by the manufacturer under document revision level control and shall be made available to the preparing or acquiring activity upon request. The test circuit shall specify the inputs, outputs, biases, and power dissipation, as applicable, in accordance with the intent specified in test method 1005.
- b.  $T_A = +125^\circ\text{C}$ , minimum.
- c. Test duration: 1,000 hours, except as permitted by method 1005 of MIL-STD-883.

4.4.2.2 Additional criteria for device classes Q and V. The steady-state life test duration, test condition and test temperature, or approved alternatives shall be as specified in the device manufacturer's QM plan in accordance with MIL-I-38535. The test circuit shall be maintained under document revision level control by the device manufacturer's TRB, in accordance with MIL-I-38535, and shall be made available to the acquiring or preparing activity upon request. The test circuit shall specify the inputs, outputs, biases, and power dissipation, as applicable, in accordance with the intent specified in test method 1005.

4.4.3 Group D inspection. The group D inspection end-point electrical parameters shall be as specified in table II herein.

<b>STANDARD MICROCIRCUIT DRAWING DEFENSE ELECTRONICS SUPPLY CENTER DAYTON, OHIO 45444</b>	<b>SIZE A</b>		5962-90602
		REVISION LEVEL	SHEET 11

DESC FORM 193A  
JUL 94

9004708 0004137 143

4.4.4 Group E inspection. Group E inspection is required only for parts intended to be marked as radiation hardness assured (see 3.5 herein). RHA levels for device classes Q and V shall be M, D, R, and H and for device class M shall be M and D.

- a. End-point electrical parameters shall be as specified in table II herein.
- b. For device class M, the devices shall be subjected to radiation hardness assured tests as specified in MIL-I-38535, appendix A, for the RHA level being tested. For device classes Q and V, the devices or test vehicle shall be subjected to radiation hardness assured tests as specified in MIL-I-38535 for the RHA level being tested. All device classes must meet the postirradiation end-point electrical parameter limits as defined in table I at  $T_A = +25^\circ\text{C} \pm 5^\circ\text{C}$ , after exposure, to the subgroups specified in table II herein.
- c. When specified in the purchase order or contract, a copy of the RHA delta limits shall be supplied.

5. PACKAGING

5.1 Packaging requirements. The requirements for packaging shall be in accordance with MIL-STD-883 (see 3.1 herein) for device class M and MIL-I-38535 for device classes Q and V.

6. NOTES

6.1 Intended use. Microcircuits conforming to this drawing are intended for use for Government microcircuit applications (original equipment), design applications, and logistics purposes.

6.1.1 Replaceability. Microcircuits covered by this drawing will replace the same generic device covered by a contractor-prepared specification or drawing.

6.1.2 Substitutability. Device class Q devices will replace device class M devices.

6.2 Configuration control of SMD's. All proposed changes to existing SMD's will be coordinated with the users of record for the individual documents. This coordination will be accomplished in accordance with MIL-STD-973 using DD Form 1692, Engineering Change Proposal.

6.3 Record of users. Military and industrial users shall inform Defense Electronics Supply Center when a system application requires configuration control and which SMD's are applicable to that system. DESC will maintain a record of users and this list will be used for coordination and distribution of changes to the drawings. Users of drawings covering microelectronic devices (FSC 5962) should contact DESC-EC, telephone (513) 296-6047.

6.4 Comments. Comments on this drawing should be directed to DESC-EC, Dayton, Ohio 45444-5270, or telephone (513) 296-5377.

6.5 Abbreviations, symbols, and definitions. The abbreviations, symbols, and definitions used herein are defined in MIL-I-38535 and MIL-STD-1331.

<b>STANDARD MICROCIRCUIT DRAWING DEFENSE ELECTRONICS SUPPLY CENTER DAYTON, OHIO 45444</b>	<b>SIZE A</b>		<b>5962-90602</b>
		<b>REVISION LEVEL</b>	<b>SHEET 12</b>

DESC FORM 193A  
JUL 94

■ 9004708 0004138 08T ■

6.6 One part - one part number system. The one part - one part number system described below has been developed to allow for transitions between identical generic devices covered by the three major microcircuit requirements documents (MIL-H-38534, MIL-I-38535, and 1.2.1 of MIL-STD-883) without the necessity for the generation of unique PIN's. The three military requirements documents represent different class levels, and previously when a device manufacturer upgraded military product from one class level to another, the benefits of the upgraded product were unavailable to the Original Equipment Manufacturer (OEM), that was contractually locked into the original unique PIN. By establishing a one part number system covering all three documents, the OEM can acquire to the highest class level available for a given generic device to meet system needs without modifying the original contract parts selection criteria.

<u>Military documentation format</u>	<u>Example PIN under new system</u>	<u>Manufacturing source listing</u>	<u>Document listing</u>
New MIL-H-38534 Standard Microcircuit Drawings	5962-XXXXXZZ(H or K)YY	QML-38534	MIL-BUL-103
New MIL-I-38535 Standard Microcircuit Drawings	5962-XXXXXZZ(Q or V)YY	QML-38535	MIL-BUL-103
New 1.2.1 of MIL-STD-883 Standard Microcircuit Drawings	5962-XXXXXZZ(M)YY	MIL-BUL-103	MIL-BUL-103

6.7 Sources of supply.

6.7.1 Sources of supply for device classes Q and V. Sources of supply for device classes Q and V are listed in QML-38535. The vendors listed in QML-38535 have submitted a certificate of compliance (see 3.6 herein) to DESC-EC and have agreed to this drawing.

6.7.2 Approved sources of supply for device class M. Approved sources of supply for class M are listed in MIL-BUL-103. The vendors listed in MIL-BUL-103 have agreed to this drawing and a certificate of compliance (see 3.6 herein) has been submitted to and accepted by DESC-EC.

<b>STANDARD MICROCIRCUIT DRAWING DEFENSE ELECTRONICS SUPPLY CENTER DAYTON, OHIO 45444</b>	<b>SIZE A</b>		<b>5962-90602</b>
		<b>REVISION LEVEL</b>	<b>SHEET 13</b>

DESC FORM 193A  
JUL 94

9004708 0004139 T16