

mass integrated

global part distribution • product lifecycle partner
excess inventory management • value-ad service provider



Data sheet provided by Mass Integrated

massintegrated.com • displayalliance.com

Please call +1.978.465.6190
Email: sales@massintegrated.com



ISO 9001: 2008

Mass Integrated complies with all DMCA takedown notices. Please send a formal DMCA Takedown Notice to Mass Integrated Systems, Inc. • 18 Henry Graf Jr. Road, Unit 1 • Newburyport, MA 01950.



EQ
Chunghwa Picture Tubes, Ltd.
Product Specification

To :
Date : 110317

LCM
CLAA070LF11CE

ACCEPTED BY : (V0.4)

APPROVED BY	CHECKED BY	PREPARED BY
張聖暉	李家銘	劉紀平

Prepared by :
Product Planning Management Division
Small & Medium TFT Product Business Unit
CHUNGHWA PICTURE TUBES, LTD.

1127 Hopin Rd., Padeh, Taoyuan, Taiwan 334, R.O.C.
TEL: +886-3-3675151 FAX: +886-3-377-3858

Doc.No:	SPEC_CLAA070LF11CE_V0.4_OD_110317	Issue Date:	2010/09/30
---------	-----------------------------------	-------------	------------

REVISION STATUS

Revision Notice	Description	Page	Rev. Date
0.0	First revision (Tentative)	17	2010/09/24
0.1	Luminance Min70->60,TYP 80->70	15	2010/11/24
0.2	Add 3D Display Application	14	2010/12/14
0.3	General specification :Power Consumption (W) :1.29(typ)	4	2011/01/13
0.3	General specification :164.9(W) x100(H) x 5.95(D)	4	2011/01/13
0.3	3.1 Typical operation conditions	6	2011/01/13
0.3	3.2 TFT-LCD current consumption: MAX	6	2011/01/13
0.3	4.1 CN1:47 DVDD 3.3V input	9	2011/01/13
0.3	6.1 Front Side	15	2011/01/13
0.3	6.2 Rear Side	16	2011/01/13
0.4	1.Overview Brightness (cd/m^2) 250nit(typ) =>300nit(typ)	4	2011/03/003
0.4	2. ABSOLUTE MAXIMUM RATINGS Delete condition item	5	2011/03/003
0.4	3.2 TFT-LCD current consumption: Min=>condition,Type=>Min	6	2011/03/003
0.4	7. optical characteristics: Luminance(CEN) Response Time:40=>35 Color Coordinate: revise all the numbers ofMin/TYP/MAX	17	2011/03/003

CONTENTS

1. OVERVIEW	4
2. ABSOLUTE MAXIMUM RATINGS	5
3. ELECTRICAL CHARACTERISTICS	6
3.1 Typical operation conditions	6
3.2 TFT-LCD current consumption.....	6
3.3 Power 、Signal sequence	7
3.4 Backlight unit	8
4. INTERFACE CONNECTION	9
4.1 CN1.....	9
5. INPUT SIGNAL	11
5.1 Timing Specification	11
5.2 DE mode	12
5.3 SYNC mode.....	13
5.4 3D Display Application.....	14
6. MECHANICAL DIMENSION	15
6.1 Front Side	15
6.2 Rear Side.....	16
7. OPTICAL CHARACTERISTICS	1
8. RELIABILITY TEST	3

1. OVERVIEW

070LF11CE is 7.0" color TFT-LCD (Thin Film Transistor Liquid Crystal Display) module composed of LCD panel, driver IC, and LED backlight.

General specification are summarized in the following table:

ITEM	SPECIFICATION
Display Area (mm)	154.08(H) × 85.92(V)
Number of Pixels	(800(H) × 3(RGB)) /2 ×480(V)
Pixel Pitch (mm)	0.1926(H) × 0.1790(V)
Color Pixel Arrangement	RGB vertical stripe
Display Mode	Normally white
Number of Colors	262,144
Brightness (cd/m ²)	300nit((typ)
Response Time (ms)	25ms (typ.)
Contrast Ratio	400(typ)
Viewing Angle (CR ≥ 10)	140degree (Horizontal.)
	120degree (Vertical)
Power Consumption (W)	1.29(typ)
Interface connection	TTL
Module Size (mm)	164.9(W) x100(H) x 5.95(D)
Module Weight (g)	165
Backlight Unit	LED
Surface Treatment	TBD
2D/3D Swithable	No
3D Optimun Viewing Distance(cm)	60(typ)

2. ABSOLUTE MAXIMUM RATINGS

The following are maximum values which, if exceeded, may cause faulty operation or damage to the unit.

ITEM	SYMBOL	MIN	MAX	UNIT	NOTE
Digital Power Supply Voltage	DVDD	-0.3	+5.0	V	
Analog Power Supply Voltage	AVDD	-0.5	+13.5	V	
Gate On Voltage	VGH	-0.3	40	V	
Gate Off Voltage	VGL	-20	0.3	V	
Gate on-Gate off Voltage	VGH-VGL	-0.3	40	V	
Signal Input Voltage	NIN0 ~ NIN2 PIN0 ~ PIN2 NINC,PINC	-0.5	5	V	
Forward Current (per LED)	I _f		30	mA	
Reverse Voltage (per LED)	VR		5	V	
Pulse forward current (per LED)	I _{fp}		100	mA	Note1
Operating temperature	Topa	-20	70	°C	Note3
Storage temperature	Tstg	-30	80	°C	Note3

Note1: I_{fp} Conditions : Duty \leq 1/10 @ Pulse Width \leq 10msec °

Note2: Each LED operating must under the condition as below drawing.
(Ambient Temperature /Allowable Forward Current)

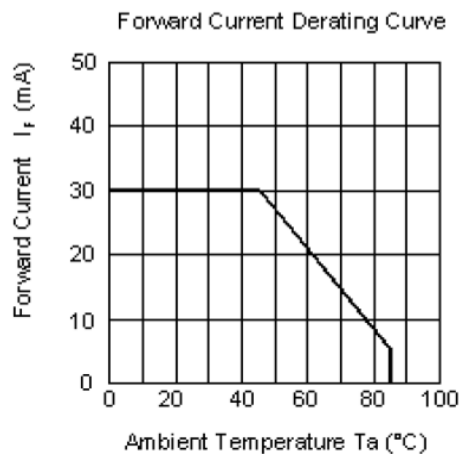

Note3: If users use the product out off the environmental operation range (temperature and humidity) , it will have visual quality concerns.

3. ELECTRICAL CHARACTERISTICS

3.1 Typical operation conditions

Ta=25°C

ITEM	SYMBOL	MIN	TYP	MAX	UNIT	NOTE
Digital Power Supply Voltage For LCD	VDD VDD_LVDS	3	3.3	3.6	V	
Logic Input Voltage	VIL	0	-	0.3xVDD	V	
	VIH	0.7xVDD	-	VDD	V	
Analog Power Supply Voltage	AVDD	9.4	9.6	9.8	V	
Gate On Power Supply Voltage	VGH	17	18	19	V	
Gate Off Power Supply Voltage	VGL	-6.6	-6	-5.4	V	
Common Power Supply Voltage	VCOM		4		V	Note1

Note1: Please adjust VCOM to make the flicker level be minimum.

3.2 TFT-LCD current consumption

ITEM	SYMBOL	CONDITIONS	MIN	MAX	UNIT	NOTE
Gate on power current	IVGH	VGH =18V	-	1	mA	Note1
Gate off power current	IVGL	VGL= -6V	-	1	mA	Note1
Digital power current	IVDD	VDD = 3.3V	-	15	mA	Note1
Analog power current	IAVDD	AVDD = 9.6V	-	40	mA	Note1
Total Power Consumption	PC		-	460	mW	Note1

Note1: Typical: Under 256 gray pattern
Maximum: Under black pattern



256 gray pattern

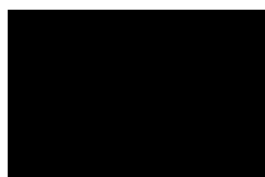

Black Pattern

3.3 Power 、 Signal sequence

Power On : VDD→AVDD/VGL →VGH →Video &Logic Signal
 Power Off : Video &Logic Signal→ VGH→AVDD/VGL→VDD

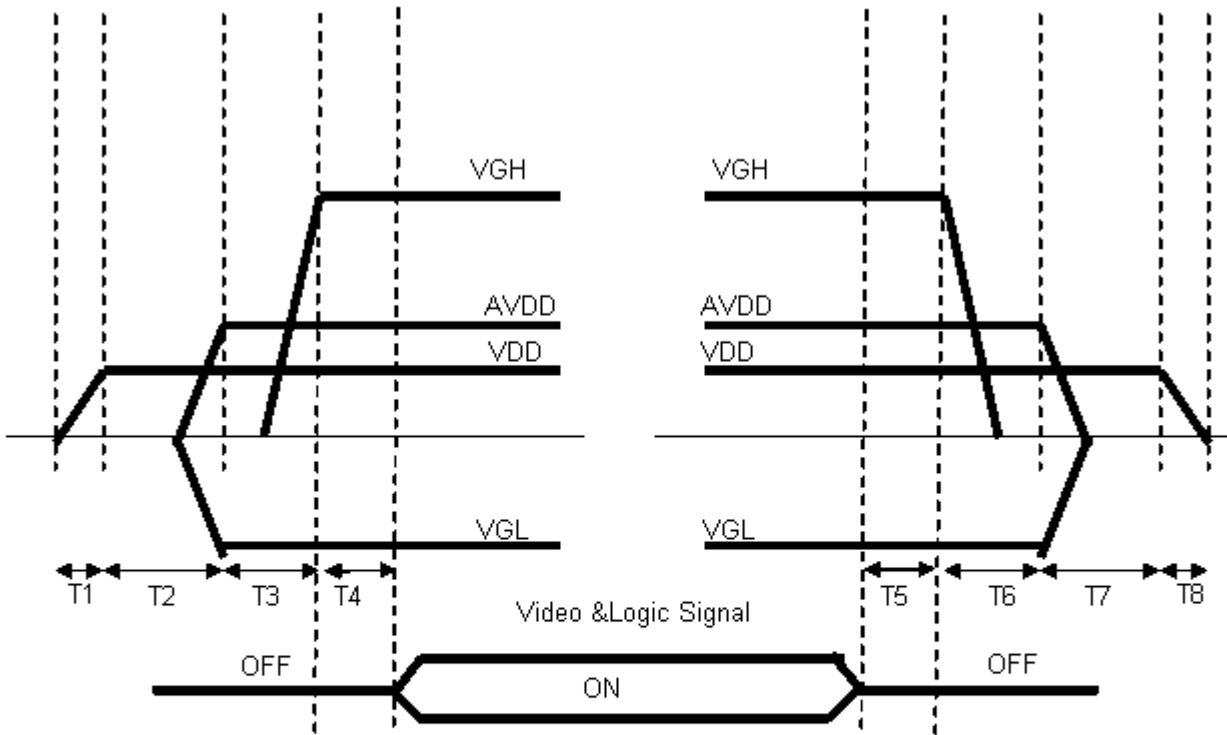

$0 < T1 \leq 10ms$
 $20ms < T2$
 $10ms < T3$
 $0 < T4 \leq 10ms$

$0 < T5 \leq 10ms$
 $0 < T6$
 $0 < T7$
 $0 < T8$

3.4 Backlight unit

ITEM	SYMBOL	CONDITIONS	MIN	TYP	MAX	UNIT	NOTE
LED current	IL	Ta=25°C (14 mA/serise)	-	84	-	mA	
LED voltage	VL	Ta=25°C (14 mA/serise)	8.2	9.0	9.8	V	
Power consumption	WL	Ta=25°C (14 mA/serise)	0.689	0.756	0.823	W	
LED Lifetime	-	Ta=25°C IF=20mA	30000			Hr	
		Ta=60°C IF=20mA	15000			Hr	

Note

1. LED Circuit Diagram :

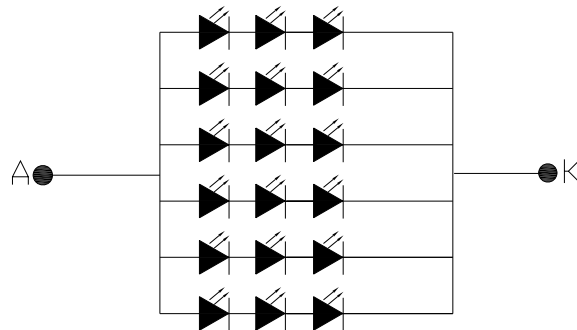

2. A : Anode(+) , K : Cathode(-)

3. LED control suggested fixed current, or it may cause the abnormal phenomenon of lighting-up.

4. Definition of the LED lifetime : Luminance(L) under 50% of initial value.

4. INTERFACE CONNECTION

4.1 CN1

Pin NO.	SYMBOL	DESCRIPTION
1	V _{LED+}	Power for LED backlight (Anode)
2	V _{LED+}	Power for LED backlight (Anode)
3	V _{LED-}	Power for LED backlight (Cathode)
4	V _{LED-}	Power for LED backlight (Cathode)
5	GND	Power ground
6	VCOM	Common Voltage
7	DVDD	Digital Power
8	MODE	DE/SYNC mode select. Normally pull high H: DE mode. L: HSD/VSD mode
9	DE	Data Enable signal
10	VSD	Vertical sync input. Negative polarity
11	HSD	Horizontal sync input. Negative polarity
12	B5	Blue Data Input
13	B4	Blue Data Input
14	B3	Blue Data Input
15	B2	Blue Data Input
16	B1	Blue Data Input
17	B0	Blue Data Input
18	GND	GND
19	GND	GND
20	G5	Green Data Input
21	G4	Green Data Input
22	G3	Green Data Input
23	G2	Green Data Input
24	G1	Green Data Input
25	G0	Green Data Input
26	GND	GND
27	GND	GND
28	R5	Red Data Input
29	R4	Red Data Input
30	R3	Red Data Input
31	R2	Red Data Input
32	R1	Red Data Input
33	R0	Red Data Input
34	GND	GND
35	GND	GND
36	GND	Power ground
37	DCLK	Clock input
38	GND	Power ground
39	SHLR	Left or Right Display Control
40	UPDN	Up / Down Display Control
41	VDDG	Positive Power for TFT
42	VEEG	Negative Power for TFT
43	AVDD	Analog Power
44	RSTB	Global reset pin. Active low to enter reset state. Suggest to connecting with an RC reset circuit for stability. Normally pull high. (R=10KΩ · C=1μF)
45	NC	Not connect
46	VCOM	Common Voltage
47	DVDD	3.3V input
48	GND	Power ground
49	NC	Not connect
50	NC	Not connect

【Note1】 SHLR : left or right setting
UPDN : up or down setting

SHLR	UPDN	Data shifting
DVDD	GND	Left→Right , Up→ Down(default)
GND	GND	Right→Left , Up→Down
DVDD	DVDD	Left→Right , Down→Up
GND	DVDD	Right→Left , Down→Up

Definition of scanning direction.

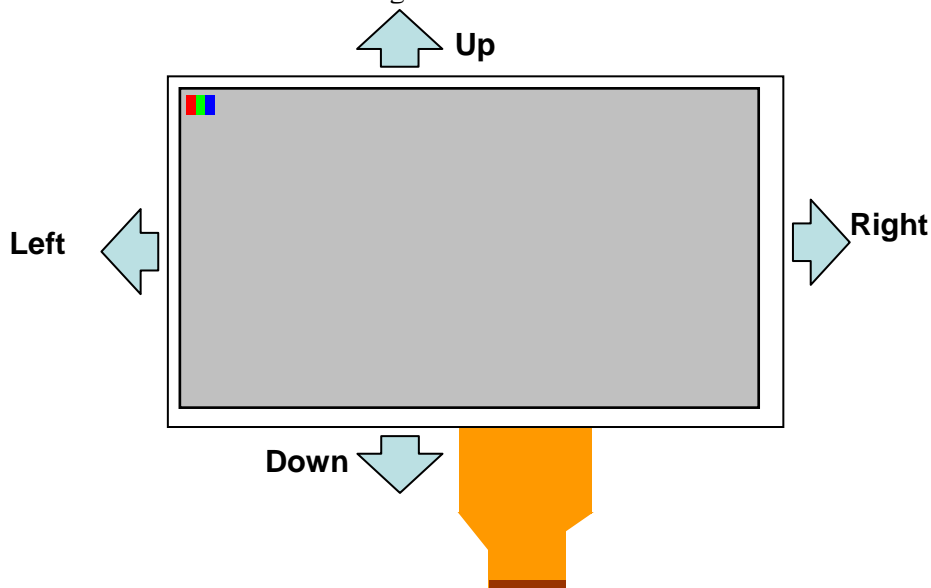

5. INPUT SIGNAL

5.1 Timing Specification

ITEM		SYMBOL	MIN.	TYP.	MAX.	UNIT	Note
DCLK	Dot Clock	$1/t_{CLK}$	29	33	38	MHz	
	DCLK pulse duty	T_{cwh}	40	50	60	%	
DE	Setup Time	T_{esu}	8	-	-	ns	
	Hold time	T_{ehd}	8	-	-	ns	
	Horizontal Period	t_H	1026	1056	1086	t_{CLK}	
	Horizontal Valid	t_{HA}	800			t_{CLK}	
	Horizontal Blank	t_{HB}	226	256	286	t_{CLK}	
	Vertical Period	t_V	515	525	535	t_H	
	Vertical Valid	t_{VA}	480			t_H	
SYNC	Vertical Blank	t_{VB}	35	45	55	t_H	
	HSYNC Setup Time	T_{hst}	8	-	-	ns	
	HSYNC Hold Time	T_{hhd}	8	-	-	ns	
	VSYNC Setup Time	T_{vst}	8	-	-	ns	
	VSYNC Hold Time	T_{vhd}	8	-	-	ns	
	Horizontal Period	t_h	1026	1056	1086	t_{CLK}	
	Horizontal Pulse Width	t_{hpw}	-	30	-	t_{CLK}	$t_{hb} + t_{hpw} = 46DCLK$ is fixed
	Horizontal Back Porch	t_{hb}	-	16	-	t_{CLK}	
	Horizontal Front Porch	t_{hfp}	180	210	240	t_{CLK}	
	Horizontal Valid	t_{hd}	800			t_{CLK}	
	Vertical Period	t_v	515	525	535	t_h	
	Vertical Pulse Width	t_{vpw}	-	13	-	t_h	$t_{vpw} + t_{vb} = 23t_h$ is fixed
	Vertical Back Porch	t_{vb}	-	10	-	t_h	
Vertical Front Porch	t_{vfp}	12	22	32	t_h		
Vertical Valid	t_{vd}	480			t_h		
DATA	Setup Time	T_{dsu}	8	-	-	ns	
	Hold Time	T_{dhd}	8	-	-	ns	

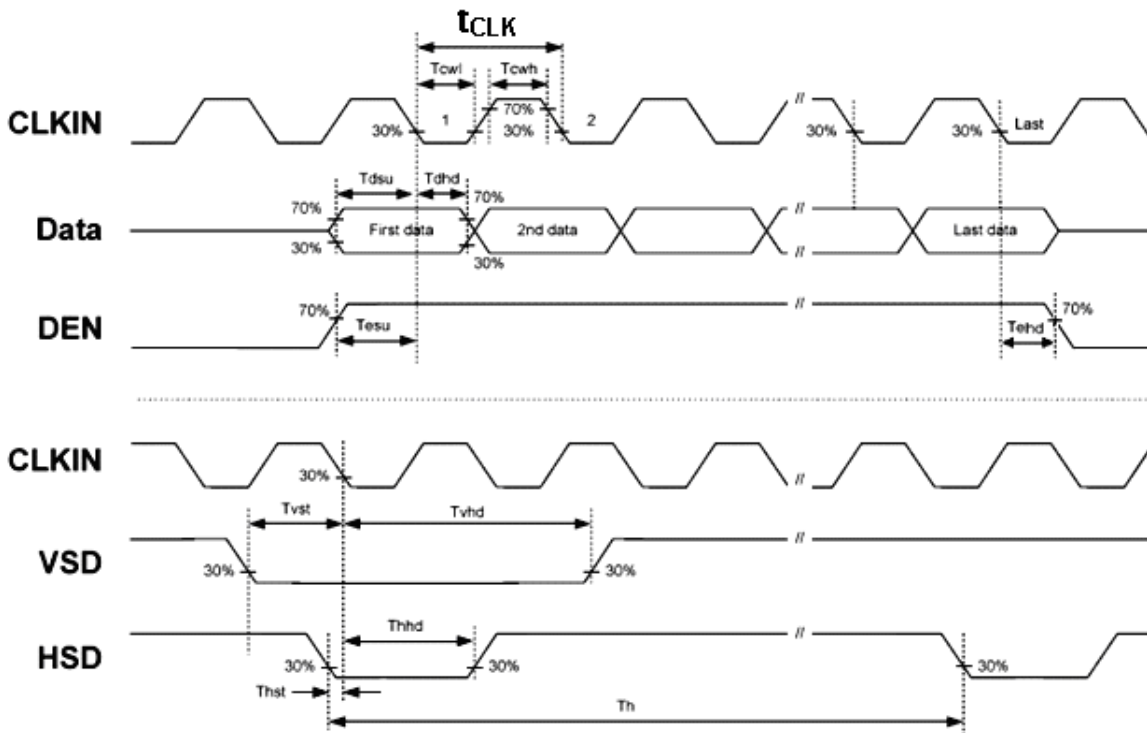

5.2 DE mode

5.2.1 Horizontal Timing Sequence

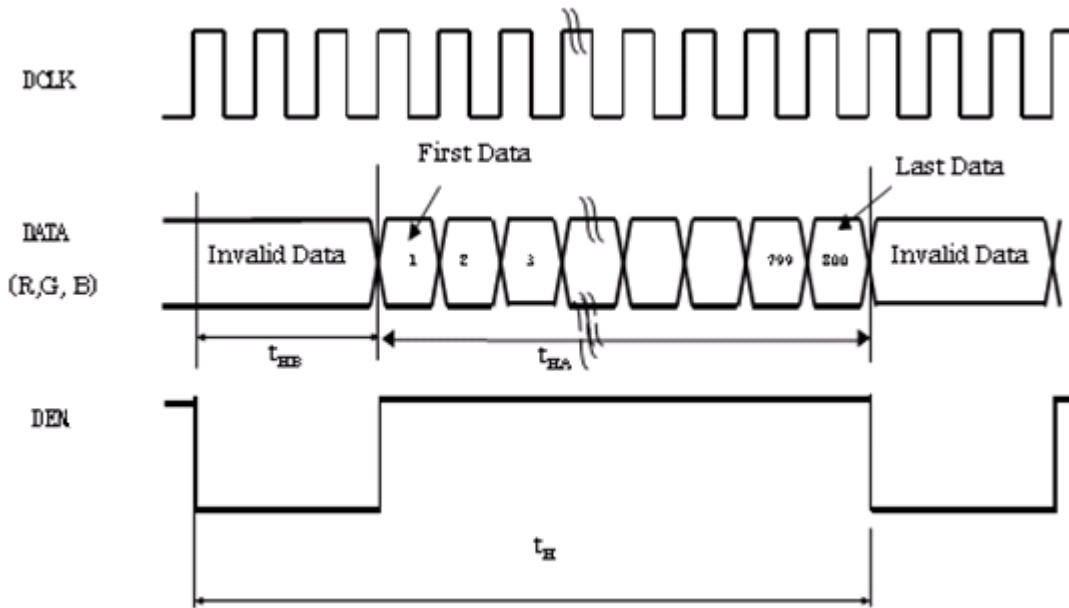

5.2.2 Vertical Timing Sequence

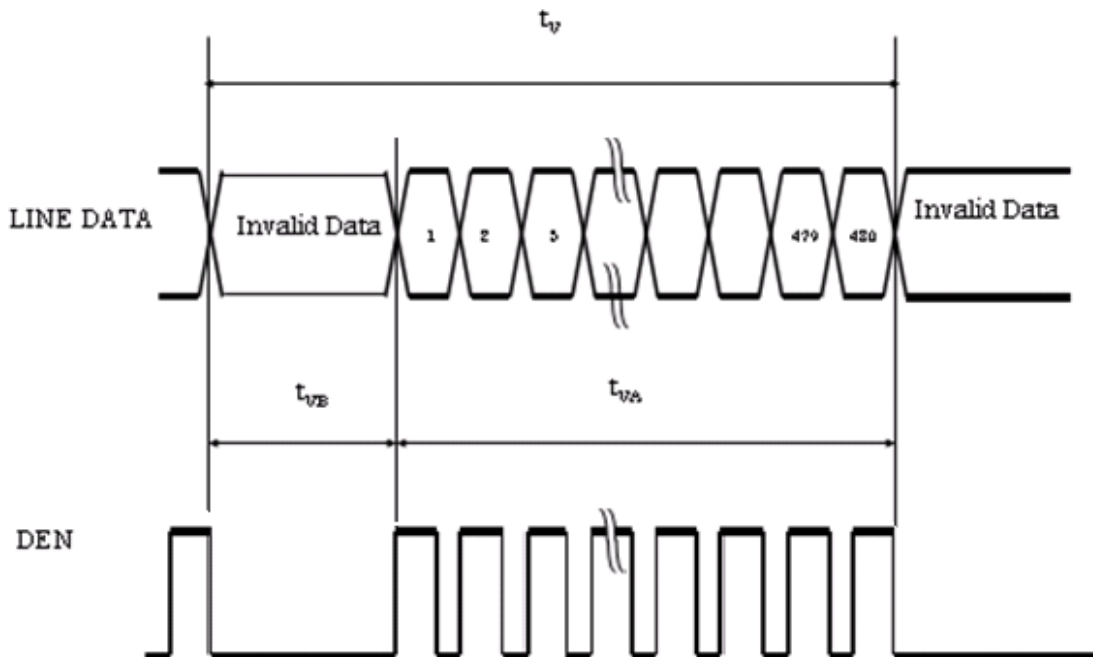

5.3 SYNC mode

5.3.1 Horizontal timing :

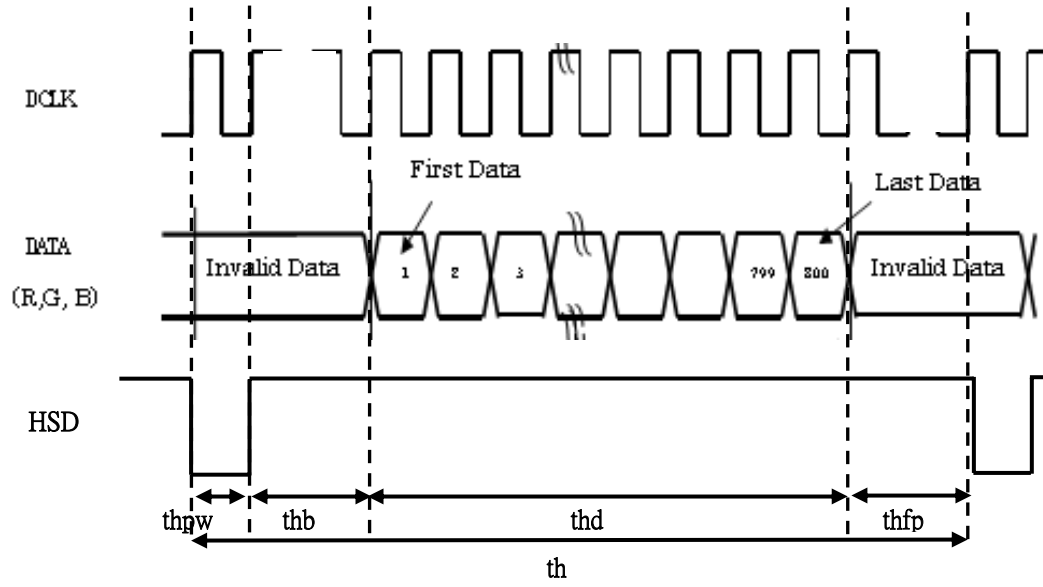

5.3.2 Vertical timing :

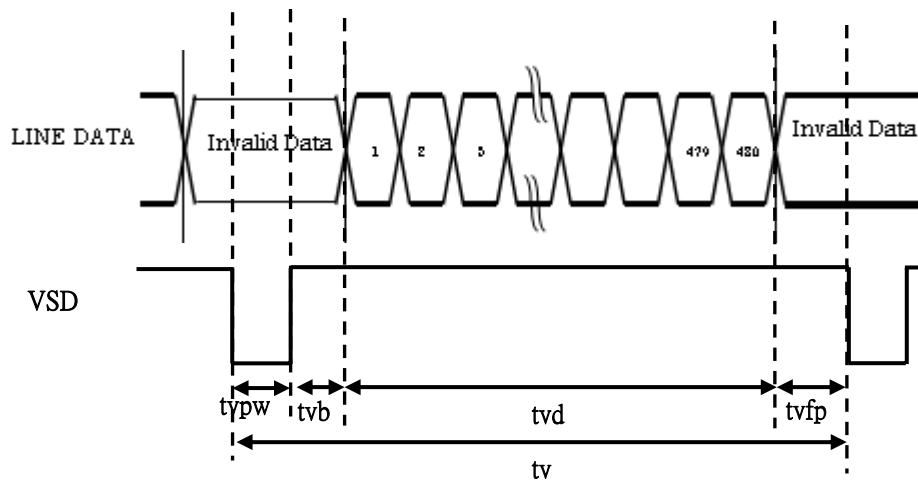

5.4 3D Display Application

5.4.1 Different viewing angle images will be rearranged like this way showed below:

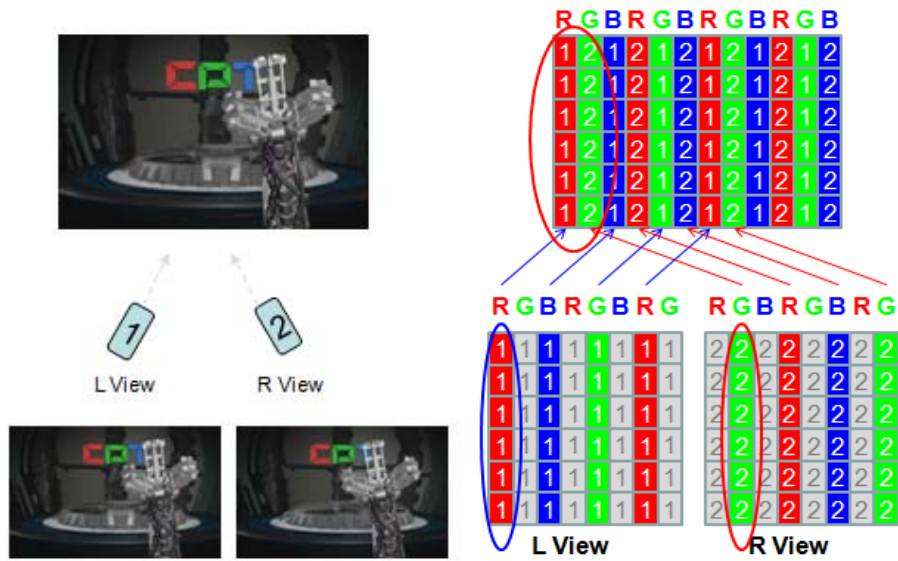

5.4.2 2D resolution is 800x480 and 3D resolution will be degraded to $(800 \times 480) \div 2$.

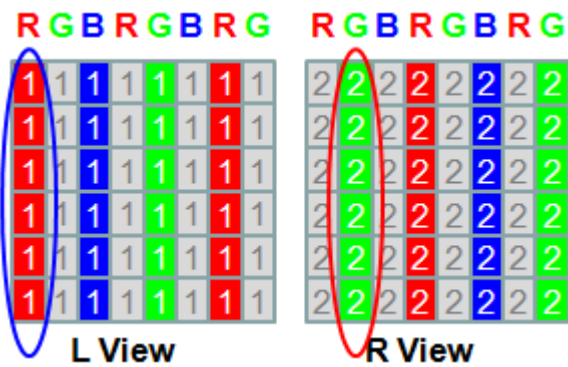

■ Gray :Don't care areas.

6. MECHANICAL DIMENSION

6.1 Front Side

[Unit : mm]

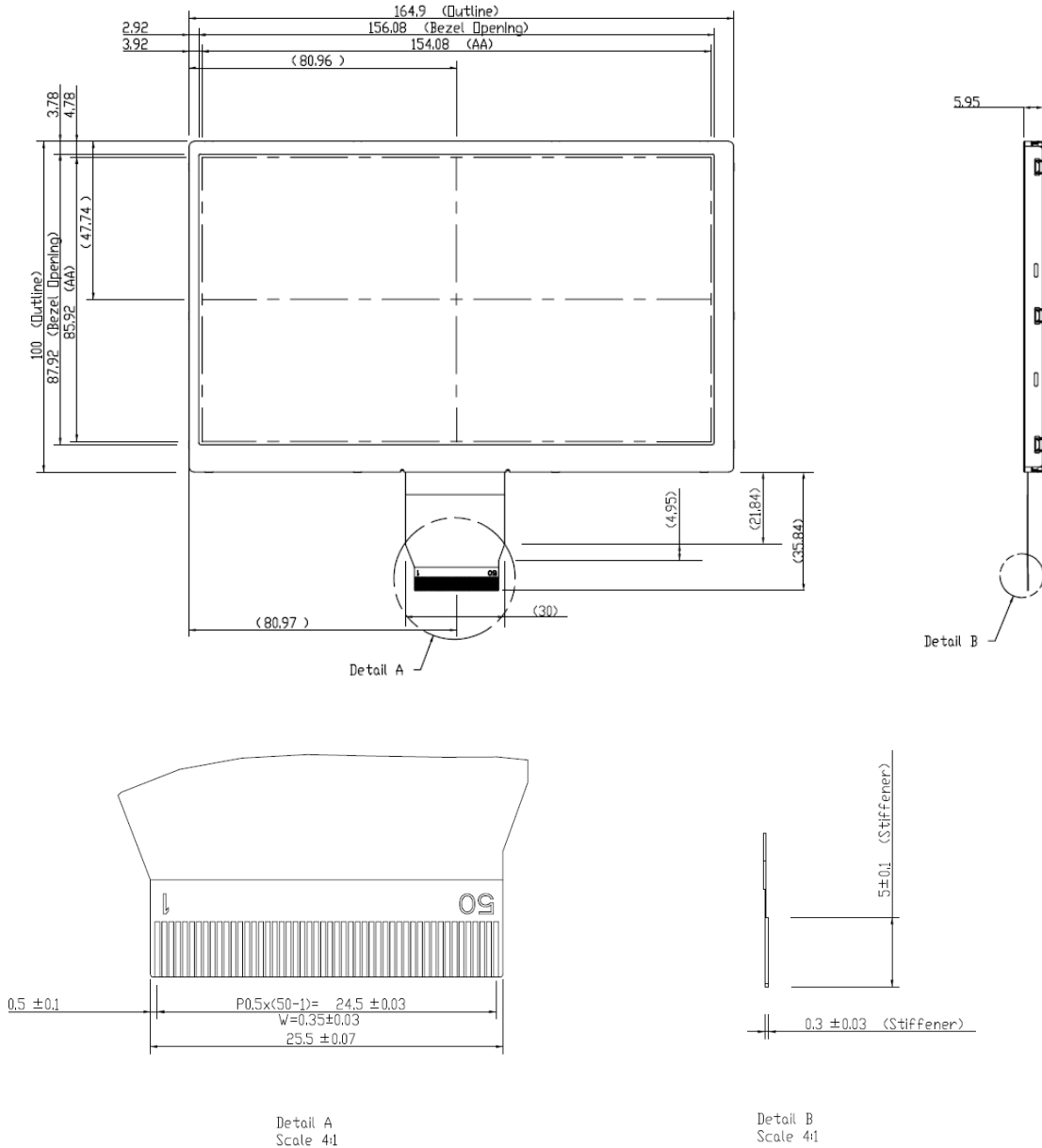

[Note]: General Tolerance = ± 0.3 mm

6.2 Rear Side

[Unit : mm]

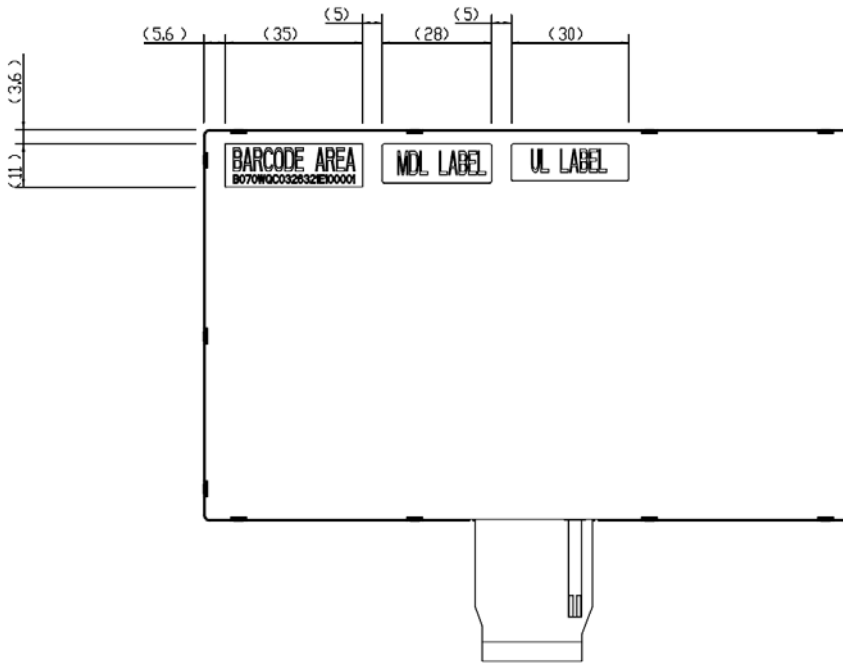

[Note]: General Tolerance = $\pm 0.3\text{mm}$

7. OPTICAL CHARACTERISTICS

Ta=25°C, VCC=3.3V

ITEM	SYMBOL	CONDITIONS	MIN	TYP	MAX	UNIT	NOTE
Constrast Ratio	CR	Point-5	-	400	-	--	1, 2, 3
Luminance(CEN)	Lw	Point-5	240	300	-	cd/m ²	1, 3
Luminance Uniformity	ΔL		60	70	-	%	1, 3
Response Time (White - Black)	Tr +Tf	Point-5	-	25	35	ms	1, 3, 5
NTSC		-	45	50		%	1, 3
Viewing Angle	Horizontal	CR ≥ 10 Point-5	120	140	-	°	1, 3
	Vertical		100	120	-	°	1, 2, 4
Color Coordinate	White	Wx Wy	0.557 0.295	0.597 0.335	0.637 0.375	--	1, 3
	Red	Rx Ry	0.308 0.557	0.348 0.597	0.388 0.637		
	Green	Gx Gy	0.123 0.076	0.163 0.116	0.203 0.156		
	Blue	Bx By	0.557 0.295	0.597 0.335	0.637 0.375		

Note1: Measure condition : 25°C±2°C , 60±10%RH , under10 Lux in the dark room.BM-5A (TOPCON) , viewing angle2° , IL=84mA (Backlight current) , measurement after lighting on 10 mins.

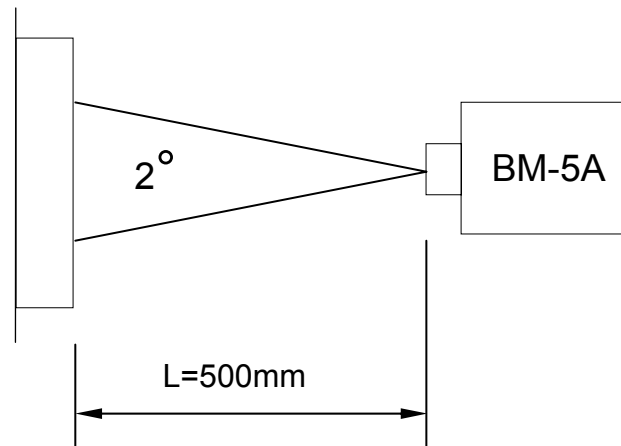

Note2: Definition of contrast ratio :

Contrast Ratio (CR)= (White) Luminance of ON ÷ (Black) Luminance of OFF

Note3: Definition of luminance : Measure white luminance on the point 5 as figure.7-1

Definition of Luminance Uniformity: Measure white luminance on the point1~9 as figure.7-1

$$\Delta L = [L(\text{MIN})/L(\text{MAX})] \times 100$$

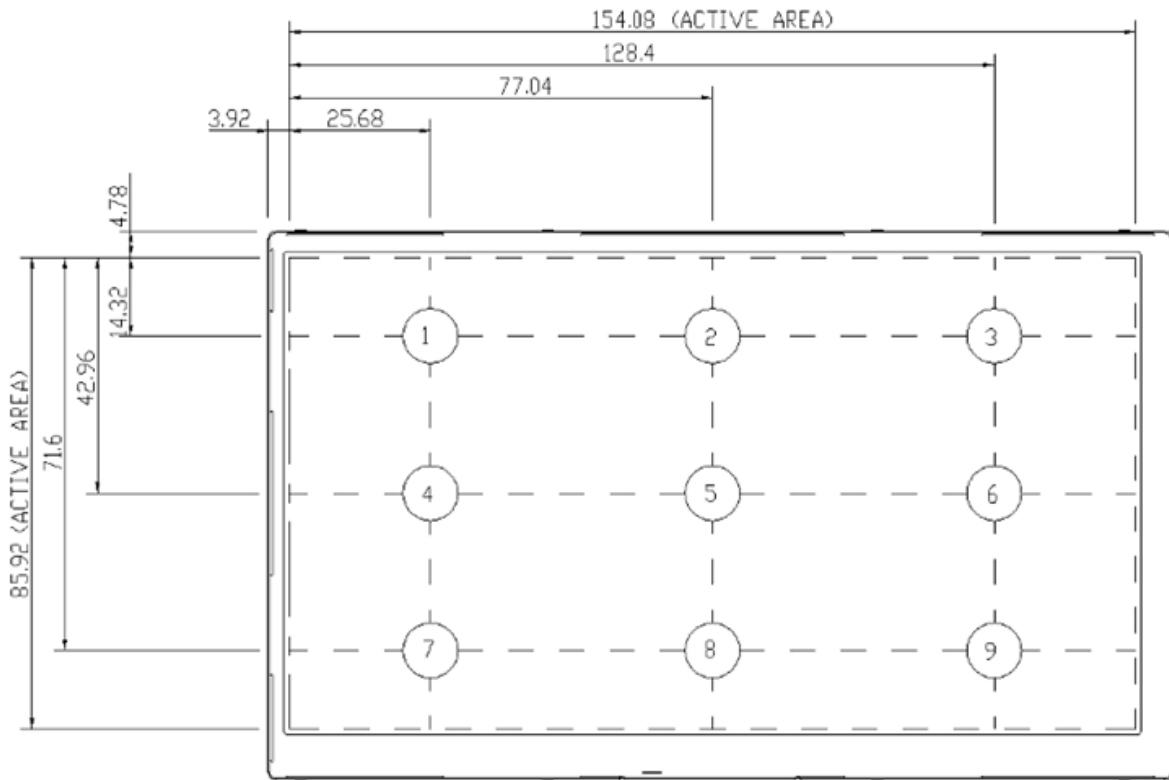

Fig.7-1 Measuring point

Note 4: Definition of Viewing Angle(θ, ψ), refer to Fig.7-2 as below :

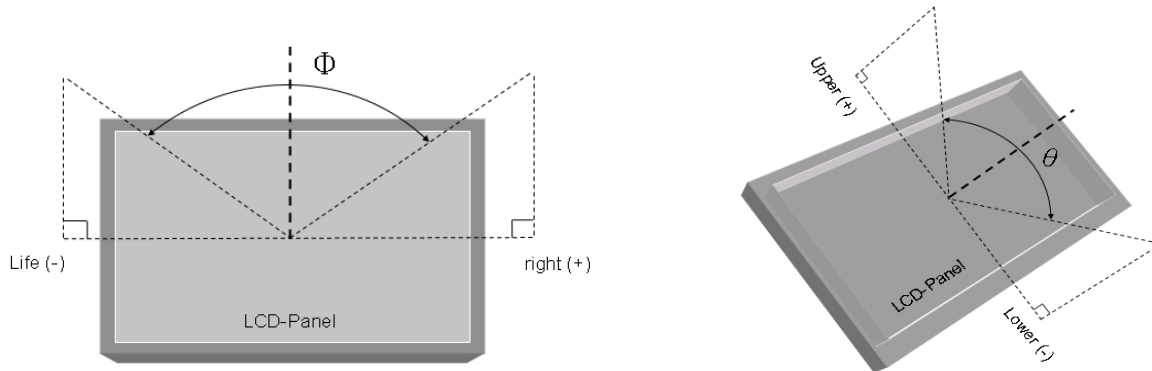

Fig.7-2 Definition of Viewing Angle

Note5: Definition of Response Time.(White-Black)

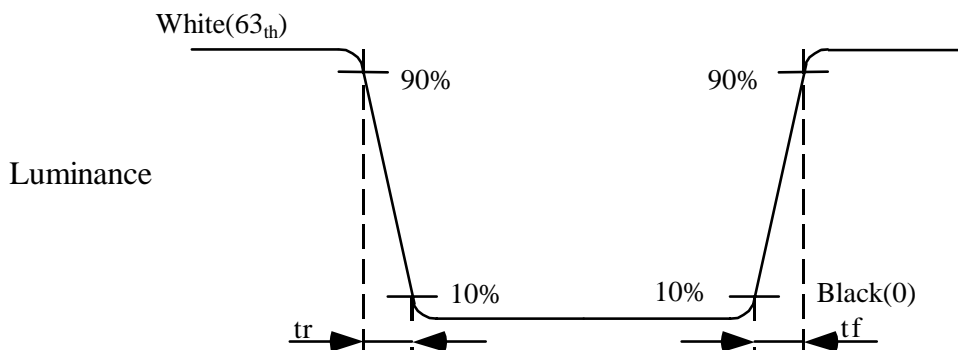

Fig.7-3 Definition of Response Time(White-Black)

8. RELIABILITY TEST

8.1. Temperature and humidity

TEST ITEMS	CONDITIONS	NOTE
High Temperature Operation	70° C , 240 Hrs	
High Temperature Storage	80° C ,240Hrs	
High Temperature High Humidity Operation	60° C , 90% RH, 240Hrs	No condensation
Low Temperature Operation	-20° C , 240 Hrs	
Low Temperature Storage	-30° C ,240Hrs	
Thermal Shock	-30° C (0.5 hr)~80° C (0.5 hr), 200 CYCLE	
Image Sticking	25° C ; 4hrs	

Note :

Condition of Image Sticking test : 25 °C ± 2 °C

Operation with test pattern sustained for 4 hrs, then change to gray pattern immediately.

After 5 mins, the mura must be disappeared completely .

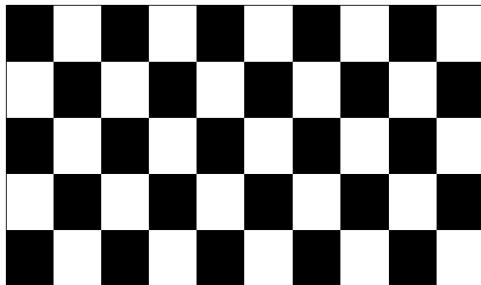

8.2. Shock and Vibration

TEST ITEMS	CONDITIONS
Shock (Non-operation)	<ul style="list-style-type: none"> ● Shock level: 980m/s²(equal to 100G). ● Waveform: half sinusoidal wave,6ms. ● Number of shocks: one shock input in each direction of three mutually perpendicular axes for a total of three shock inputs.
Vibration (Non-operation)	<ul style="list-style-type: none"> ● Frequency range:8~33.3Hz ● Stoke : 1.3 mm ● Vibration: sinusoidal wave, perpendicular axis(both x, y,z axis: 2Hrs). ● Sweep: 2.9G,33.3 Hz -400 Hz ● Cycle: 15 min

8.3 ESD

TEST ITEM	CONDITIONS	Note
ESD	150pF , 330Ω , ±8kV&±15kV air& contact test	1
	200pF , 0Ω , ±200V contact test	2

Note: Measure

1: LCD glass and metal bezel

2: IF connector pins

8.4. Judgment standard

The Judgment of the above test should be made as follow:

Pass:Normal display image with no obvious non-uniformity and no line defect.Partial transformation of the module parts should be ignored.

Fail:No display image,obvious non-uniformity,or line defect.