

**Silicon PIN Diode**

- PIN diode for high speed switching of RF signals
- Low forward resistance, small capacitance  
small inductance
- Very low capacitance
- For frequencies up to 3 GHz

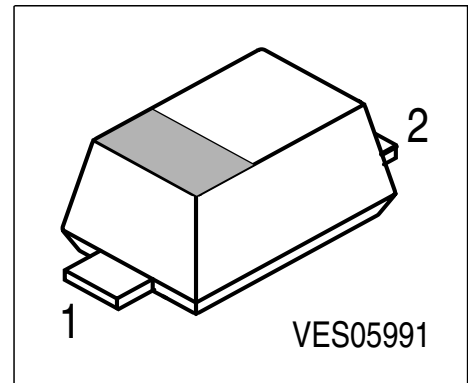

Type	Marking	Pin Configuration		Package
BAR 63-02V	GG	1 = C	2 = A	SC-79

**Maximum Ratings**

Parameter	Symbol	Value	Unit
Diode reverse voltage	$V_R$	50	V
Forward current	$I_F$	100	mA
Total power dissipation, $T_S = 115\text{ °C}$	$P_{tot}$	250	mW
Junction temperature	$T_j$	150	°C
Operating temperature range	$T_{op}$	-55 ... 150	°C
Storage temperature	$T_{stg}$	-55 ... 150	

**Thermal Resistance**

Junction - ambient <sup>1)</sup>	$R_{thJA}$	≤ 220	K/W
Junction - soldering point	$R_{thJS}$	≤ 140	K/W

1) Package mounted on alumina 15mm x 16.7mm x 0.7mm

**Electrical Characteristics** at  $T_A = 25\text{ }^\circ\text{C}$ , unless otherwise specified.

Parameter	Symbol	Values			Unit
		min.	typ.	max.	
<b>DC characteristics</b>					
Breakdown voltage $I_{(BR)} = 5\text{ }\mu\text{A}$	$V_{(BR)}$	50	-	-	V
Reverse current $V_R = 35\text{ V}$	$I_R$	-	-	10	nA
Forward voltage $I_F = 100\text{ mA}$	$V_F$	-	0.95	1.2	V
<b>AC characteristics</b>					
Diode capacitance $V_R = 0\text{ V}, f = 100\text{ MHz}$ $V_R = 5\text{ V}, f = 1\text{ MHz}$	$C_T$	-	0.3	-	pF
		-	0.21	0.3	
Case capacitance $f = 1\text{ MHz}$	$C_C$	-	0.09	-	
Forward resistance $I_F = 5\text{ mA}, f = 100\text{ MHz}$ $I_F = 10\text{ mA}, f = 100\text{ MHz}$	$r_f$	-	1.2	2	$\Omega$
		-	1	-	
Charge carrier life time $I_F = 10\text{ mA}, I_R = 6\text{ mA}, I_R = 3\text{ mA}$	$\tau_{rr}$	-	75	-	ns
Series inductance	$L_S$	-	0.6	-	nH

**Forward current  $I_F = f(T_A^*; T_S)$**

\*) : mounted on alumina 15mm x 16.7mm x 0.7m

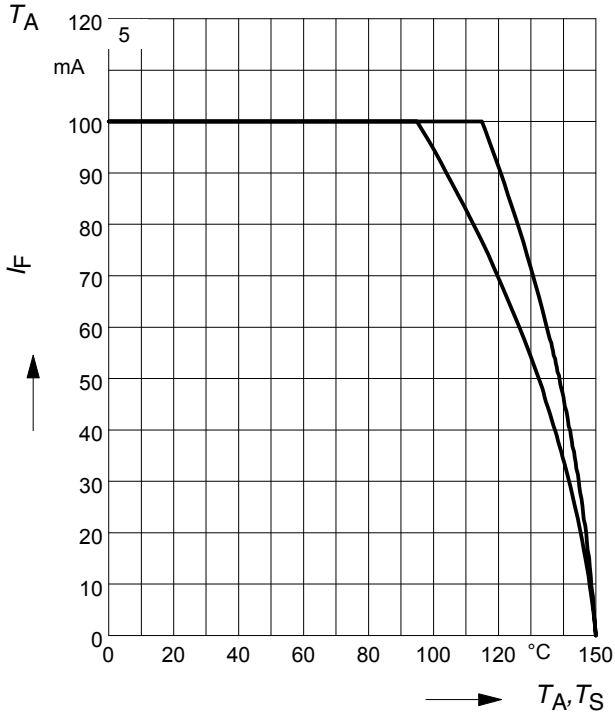

**Permissible Pulse Load  $R_{thJS} = f(t_p)$**

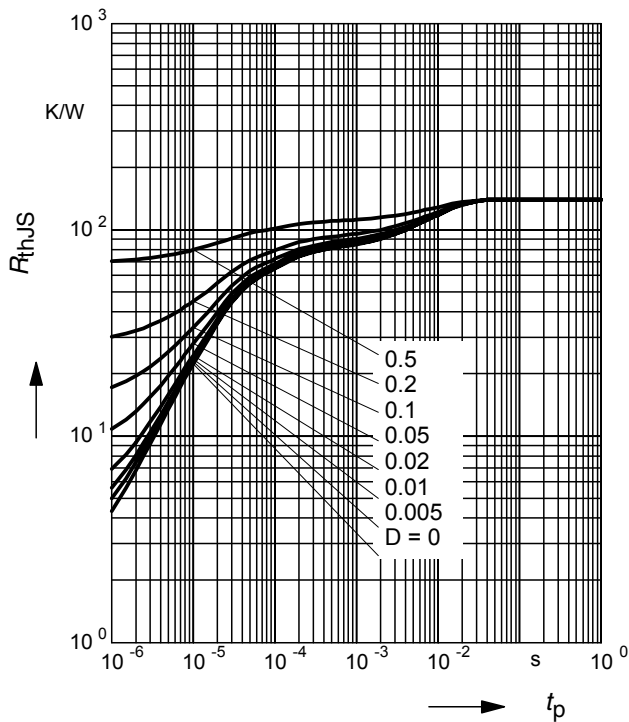

**Permissible Pulse Load**

$I_{Fmax} / I_{FDC} = f(t_p)$

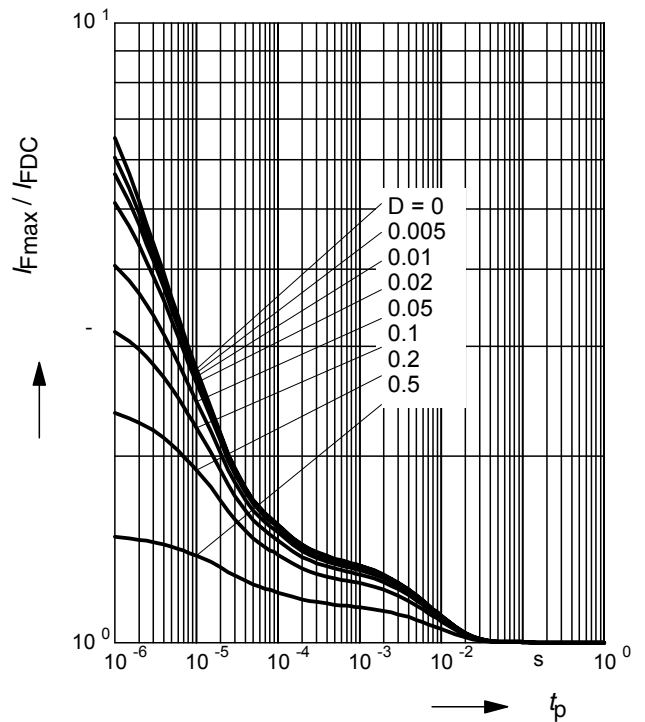

**Diode capacitance  $C_T = f(V_R)$**

$f = 1\text{MHz}$

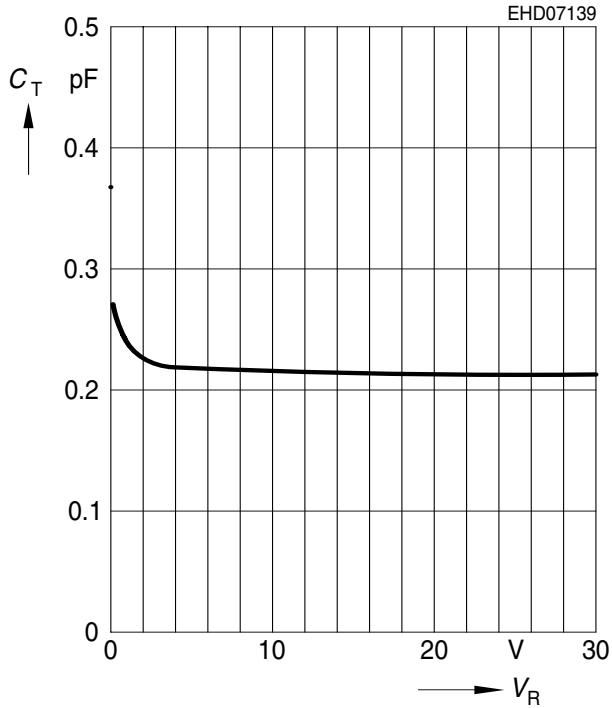

**Forward resistance  $r_f = f(I_F)$**

$f = 100\text{MHz}$

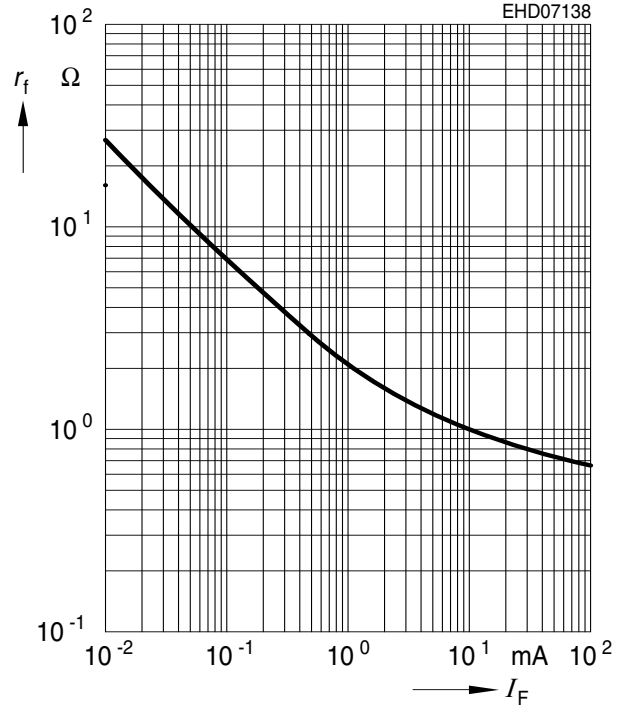

**Forward current  $I_F = f(V_F)$**

$T_A = 25^\circ\text{C}$

