



Am486[®] DX4 3-Volt Processor

High-Performance, Clock-Selectable, 3.3 V, 32-Bit Microprocessor

DISTINCTIVE CHARACTERISTICS

■ Operating voltage range 3.3 V \pm 0.3 V

- 120-MHz operating frequency uses a 40-MHz external bus
- 100-MHz operating frequency uses a 33-MHz external bus
- Wide range of chipsets and support available through the AMD FusionPCSM Program

■ High Integration On-Chip

- 8-Kbyte code and data cache
- Floating-point unit
- Paged, virtual memory management

■ High-Performance Design

- Frequent instructions execute in one clock
- 105.6-Million bytes/second burst bus at 33 MHz
- 128-Million bytes/second burst bus at 40 MHz
- 0.5-micron CMOS process technology
- Dynamic bus sizing for 8, 16, and 32-bit buses

■ Complete 32-Bit Architecture

- Address and data buses
- All registers
- 8, 16, and 32-bit data types

■ Multiprocessor Support

- Multiprocessor instructions
- Cache consistency protocols
- Support for second-level cache

■ Standard 168-Pin PGA Package

■ Supports Environmental Protection Agency's (EPA) "Energy Star" program

- Energy management capability provides excellent base for energy-efficient design
- Works with a variety of energy efficient, power managed devices

GENERAL DESCRIPTION

The Am486DX4 microprocessor is a high-performance 486 desktop solution that provides optimal price/performance for high-end 486 power-managed systems. The Am486DX4 CPU offers superior local bus graphics performance for Microsoft[®] Windows[®].

Using AMD's speed-multiplying technology, the Am486DX4 CPU and cache operate two to three times faster than the external memory bus. It is manufactured using AMD's new 3.3-V CMOS process technology to consume about 2.6 watts of power at 100 MHz or 3.2 watts at 120 MHz. This 3.3-V technology provides superior solutions for low-power EPA's Energy Star Green PCs and portables.

The Am486DX4 processor operates with a 1X clock input. This 1X clock simplifies system design by reducing the clock frequency required by external devices. The 1X clock also reduces RF emission and simplifies clock generation. The input signal is doubled or tripled internally to achieve the maximum 2X or 3X operating frequency. The phases of the core clock are controlled by an internal Phase Lock Loop (PLL) circuit.

BLOCK DIAGRAM

Am486 CPU Pipelined 32-Bit Microarchitecture

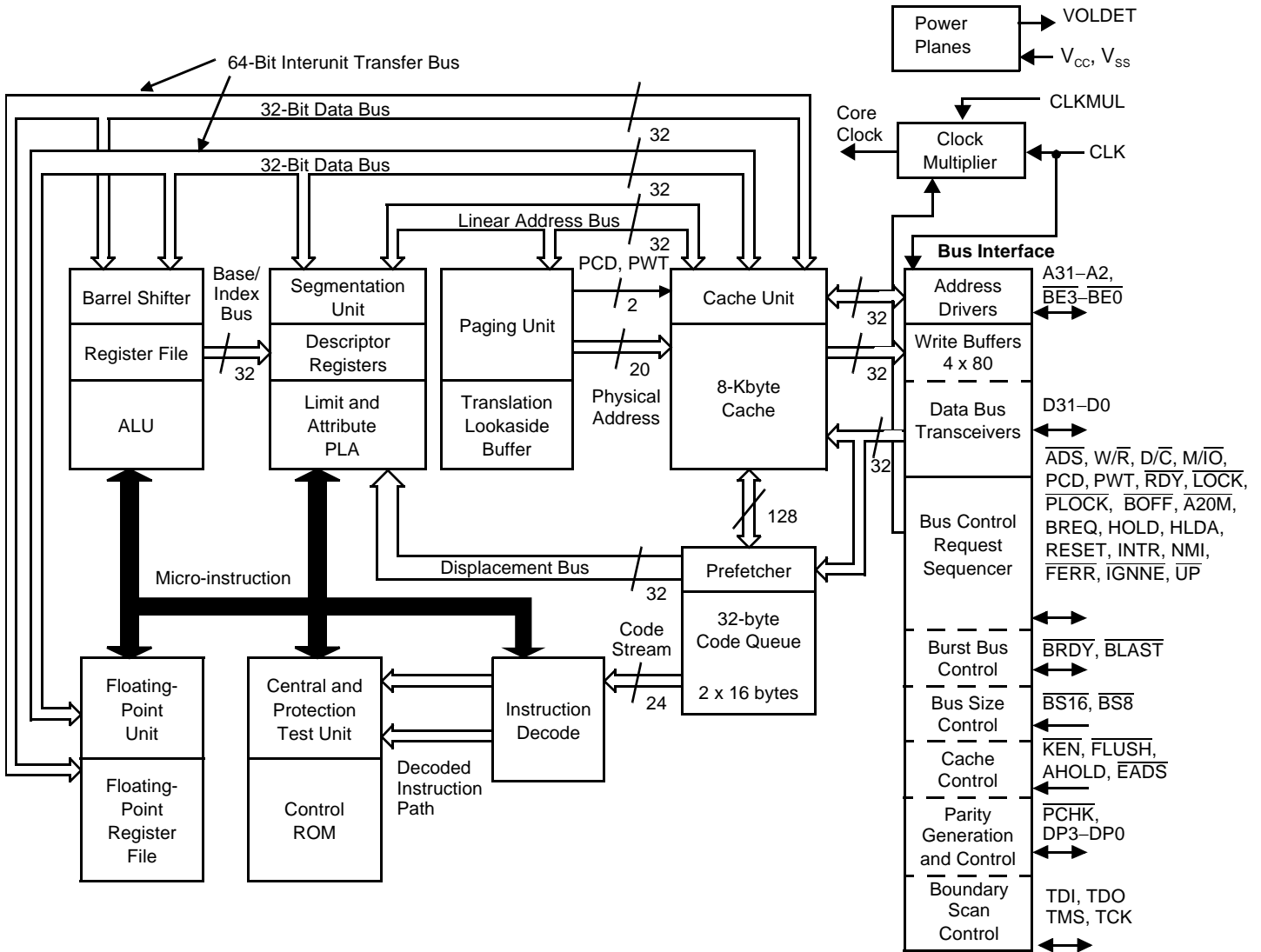

19160C-001

ORDERING INFORMATION

Standard Products

AMD standard products are available in several packages and operating ranges. The order number (Valid Combination) is formed by a combination of the elements below.

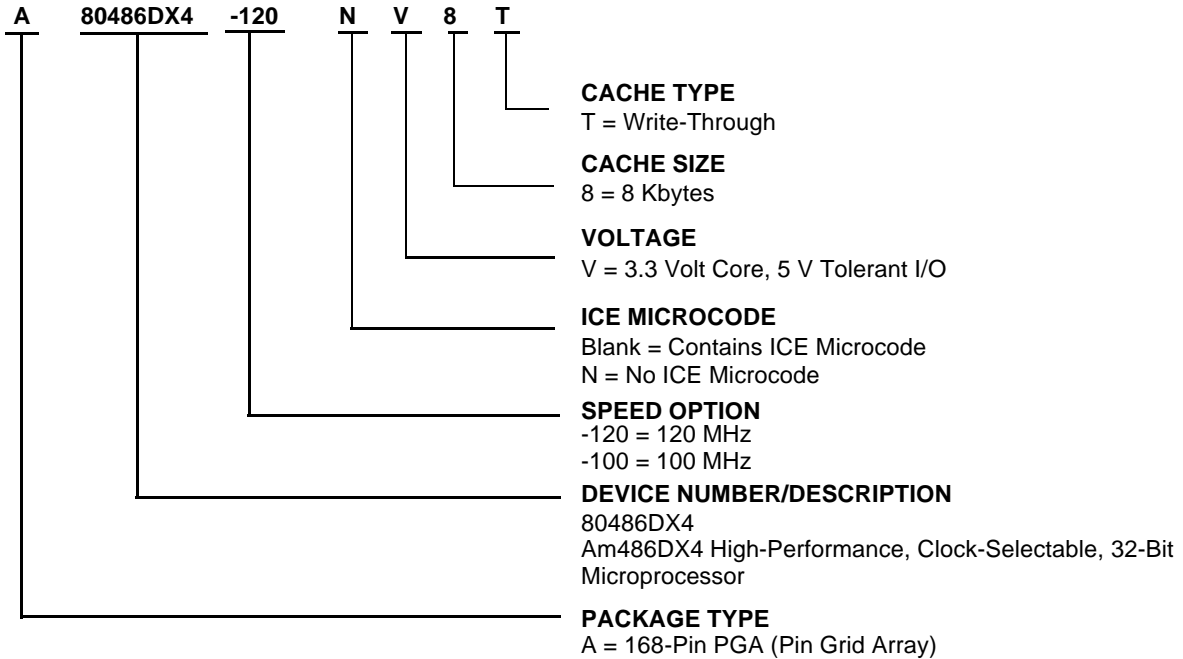

Valid Combinations		
A	80486DX4	-120NV8T -100NV8T

Valid Combinations

Valid Combinations list configurations planned to be supported in volume for this device. Consult the local AMD sales office to confirm availability of specific valid combinations and to check on newly released combinations.

CONNECTION DIAGRAMS

Am486DX4 CPU
Pin Side View

168-Pin PGA (Pin Grid Array) Package

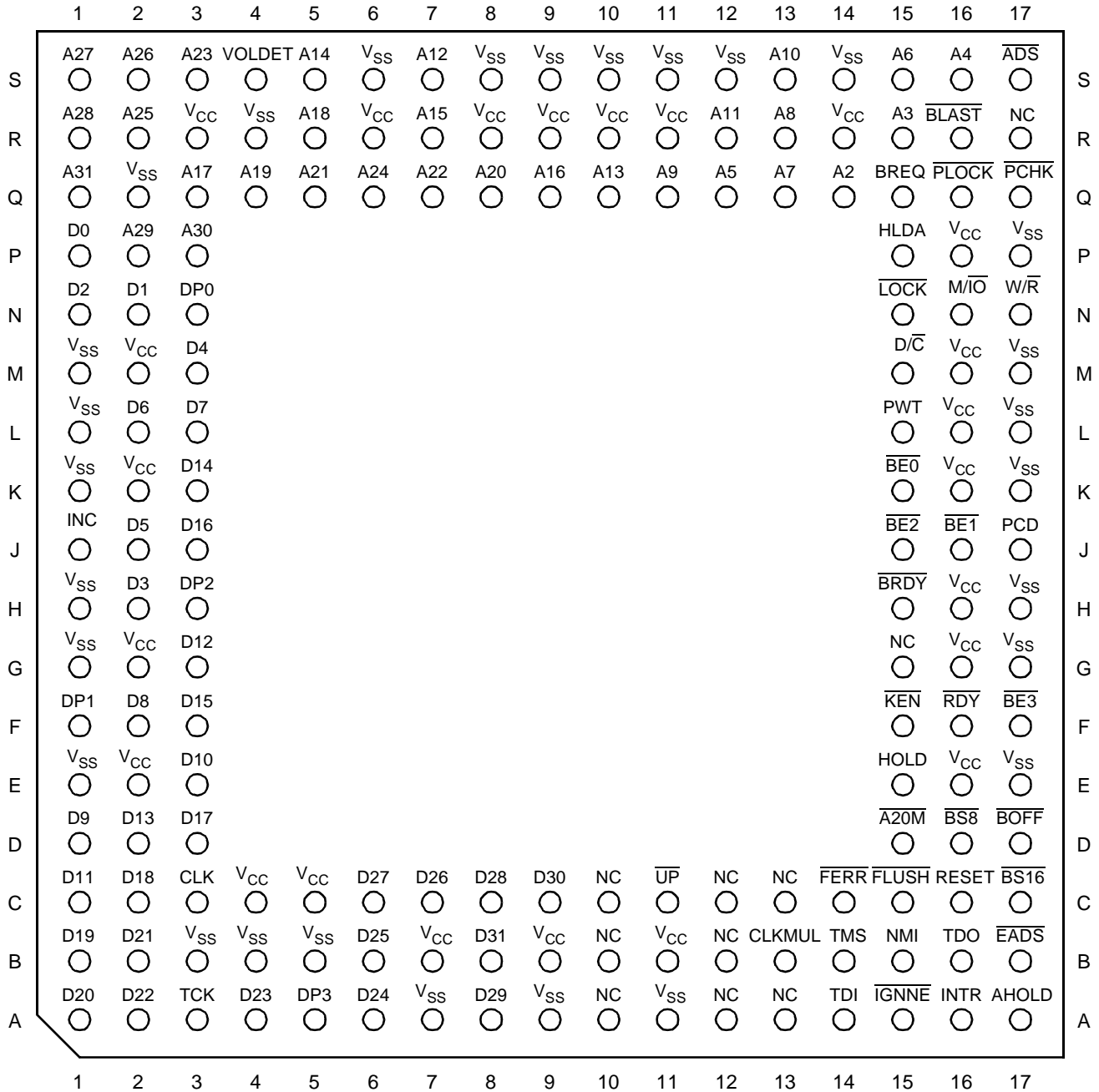

Note:

NC = No connect. To guarantee functionality with future revisions, these pins must not be connected.

19160c-002

CONNECTION DIAGRAMS

Am486DX4 CPU
Top Side View

168-Pin PGA (Pin Grid Array) Package

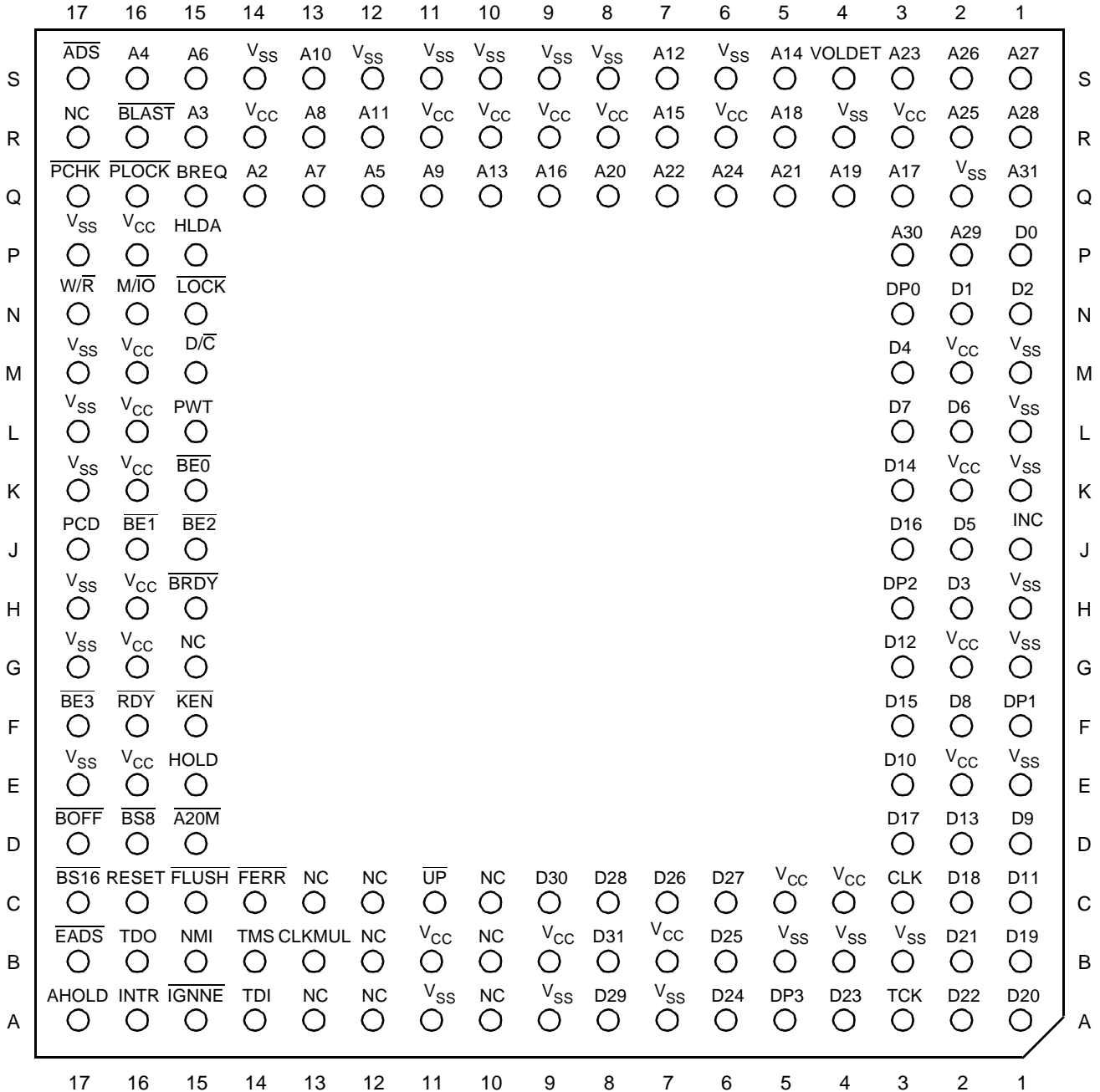

19160c-003

Note:
NC = No connect. To guarantee functionality with future revisions, these pins must not be connected.

PIN DESIGNATIONS (Functional Grouping)

Address		Data		Control		Test		INC/NC	V _{cc}	V _{ss}
Pin Name	Pin No.	Pin Name	Pin No.	Pin Name	Pin No.	Pin Name	Pin No.	Pin No.	Pin No.	Pin No.
A2	Q-14	D0	P-1	$\overline{A20M}$	D-15	TCK	A-3	A-10	B-7	A-7
A3	R-15	D1	N-2	ADS	S-17	TDI	A-14	A-12	B-9	A-9
A4	S-16	D2	N-1	AHOLD	A-17	TDO	B-16	A-13	B-11	A-11
A5	Q-12	D3	H-2	$\overline{BE0}$	K-15	TMS	B-14	B-10	C-4	B-3
A6	S-15	D4	M-3	$\overline{BE1}$	J-16			B-12	C-5	B-4
A7	Q-13	D5	J-2	$\overline{BE2}$	J-15			C-10	E-2	B-5
A8	R-13	D6	L-2	$\overline{BE3}$	F-17			C-12	E-16	E-1
A9	Q-11	D7	L-3	\overline{BLAST}	R-16			C-13	G-2	E-17
A10	S-13	D8	F-2	\overline{BOFF}	D-17			G-15	G-16	G-1
A11	R-12	D9	D-1	\overline{BRDY}	H-15			J-1	H-16	G-17
A12	S-7	D10	E-3	BREQ	Q-15			R-17	K-2	H-1
A13	Q-10	D11	C-1	$\overline{BS8}$	D-16				K-16	H-17
A14	S-5	D12	G-3	$\overline{BS16}$	C-17				L-16	K-1
A15	R-7	D13	D-2	CLK	C-3				M-2	K-17
A16	Q-9	D14	K-3	CLKMUL	B-13				M-16	L-1
A17	Q-3	D15	F-3	$\overline{D/C}$	M-15				P-16	L-17
A18	R-5	D16	J-3	DP0	N-3				R-3	M-1
A19	Q-4	D17	D-3	DP1	F-1				R-6	M-17
A20	Q-8	D18	C-2	DP2	H-3				R-8	P-17
A21	Q-5	D19	B-1	DP3	A-5				R-9	Q-2
A22	Q-7	D20	A-1	\overline{EADS}	B-17				R-10	R-4
A23	S-3	D21	B-2	\overline{FERR}	C-14				R-11	S-6
A24	Q-6	D22	A-2	\overline{FLUSH}	C-15				R-14	S-8
A25	R-2	D23	A-4	HLDA	P-15					S-9
A26	S-2	D24	A-6	HOLD	E-15					S-10
A27	S-1	D25	B-6	\overline{IGNNE}	A-15					S-11
A28	R-1	D26	C-7	INTR	A-16					S-12
A29	P-2	D27	C-6	\overline{KEN}	F-15					S-14
A30	P-3	D28	C-8	\overline{LOCK}	N-15					
A31	Q-1	D29	A-8	$\overline{M/IO}$	N-16					
		D30	C-9	NMI	B-15					
		D31	B-8	PCD	J-17					
				\overline{PCHK}	Q-17					
				\overline{PLOCK}	Q-16					
				PWT	L-15					
				\overline{RDY}	F-16					
				RESET	C-16					
				UP	C-11					
				VOLDET	S-4					
				$\overline{W/R}$	N-17					

Notes:

INC = Internal No Connect (J-1).

NC = No Connect (A-10, A-12, A-13, B-10, B-12, C-10, C-12, C-13, G-15, R-17).

VOLDET is connected internally to V_{ss}.

LOGIC SYMBOL

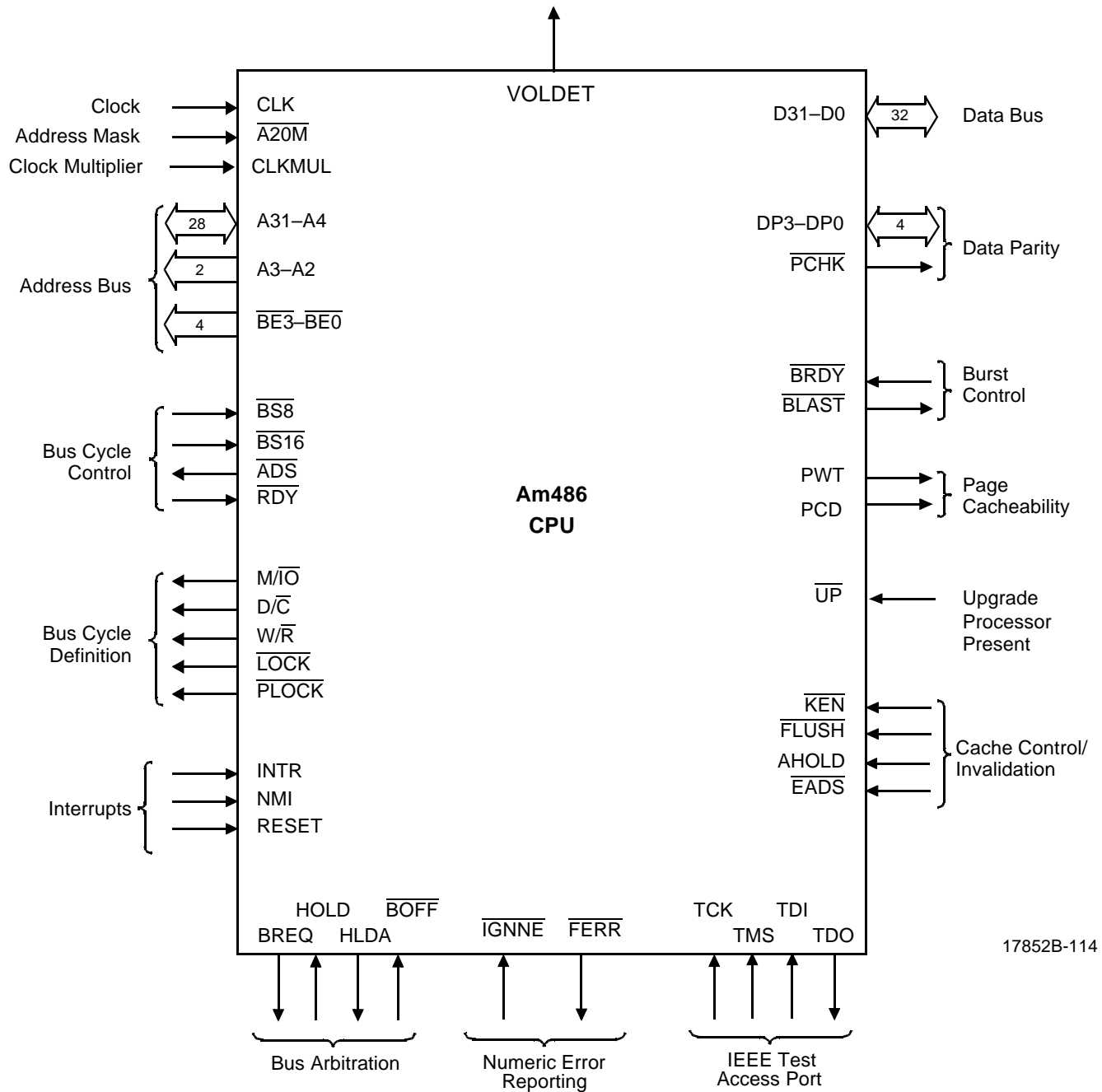

PIN DESCRIPTIONS

The following paragraphs define the Am486DX4 CPU pins (signals).

A31–A4/A3–A2

Address Lines (Inputs/Outputs)/(Outputs)

A31–A2, together with the byte enables $\overline{\text{BE}}_3$ – $\overline{\text{BE}}_0$, define the physical area of memory or input/output space accessed. Address lines A31–A4 are used to drive addresses into the microprocessor to perform cache line invalidations. Input signals must meet setup and hold times, t_{22} and t_{23} . A31–A2 are not driven during bus or address hold.

A20M

Address Bit 20 Mask (Active Low; Input)

When asserted, the Am486DX4 microprocessor masks physical address bit 20 (A20) before performing a look-up to the internal cache or driving a memory cycle on the bus. $\overline{\text{A20M}}$ emulates the address wraparound at 1 Mbyte, which occurs on the 8086. $\overline{\text{A20M}}$ is active Low and should be asserted only when the processor is in Real Mode. This pin is asynchronous but should meet setup and hold times, t_{20} and t_{21} , for recognition in any specific clock. For proper operation, $\overline{\text{A20M}}$ should be sampled High at the falling edge of RESET.

ADS

Address Status (Active Low; Output)

ADS indicates that a valid bus cycle definition and address are available on the cycle definition lines and address bus. ADS is driven active in the same clock as the addresses are driven. ADS is active Low and is not driven during bus hold.

AHOLD

Address Hold (Active High; Input)

This request allows another bus master access to the Am486DX4 microprocessor's address bus for a cache invalidation cycle. The Am486DX4 microprocessor stops driving its address bus in the clock following AHOLD going active. Only the address bus is floated during address hold; the remainder of the bus remains active. AHOLD is active High and is provided with a small internal pull-down resistor. For proper operation, AHOLD must meet setup and hold times, t_{18} and t_{19} .

$\overline{\text{BE}}_3$ – $\overline{\text{BE}}_0$

Byte Enables (Active Low; Outputs)

These pins indicate active bytes during read and write cycles. During the first cycle of a cache fill, the external system should assume that all byte enables are active. $\overline{\text{BE}}_3$ applies to D31–D24, $\overline{\text{BE}}_2$ applies to D23–D16, $\overline{\text{BE}}_1$ applies to D15–D8, and $\overline{\text{BE}}_0$ applies to D7–D0. $\overline{\text{BE}}_3$ – $\overline{\text{BE}}_0$ are active Low and are not driven during bus hold.

The Am486DX4 processor provides four special bus cycles to indicate that certain instructions have been executed, or certain conditions have occurred internally. The special bus cycles (in Table 1) are defined when the bus cycle definition pins are in the following state: $\overline{\text{M}}/\overline{\text{IO}}=0$, $\overline{\text{D}}/\overline{\text{C}}=0$, and $\overline{\text{W}}/\overline{\text{R}}=1$. During these cycles the address bus is driven Low while the data bus is undefined.

The external hardware must acknowledge these special bus cycles by returning $\overline{\text{RDY}}$ and $\overline{\text{BRDY}}$.

Table 1 . Special Bus Cycle Encoding

$\overline{\text{BE}}_3$	$\overline{\text{BE}}_2$	$\overline{\text{BE}}_1$	$\overline{\text{BE}}_0$	Special Bus Cycles
1	1	1	0	Shutdown
1	1	0	1	Flush
1	0	1	1	Halt
0	1	1	1	Write Back

$\overline{\text{BS}}_8/\overline{\text{BS}}_{16}$

Bus Size 8 (Active Low; Input)

Bus Size 16 (Active Low; Input)

These pins cause the Am486DX4 microprocessor to run multiple bus cycles to complete a request from devices that cannot provide or accept 32 bits of data in a single cycle. The bus sizing pins are sampled every clock. The state of these pins in the clock before $\overline{\text{RDY}}$ is used by the Am486DX4 microprocessor to determine the bus size. These signals are active Low and are provided with internal pull-up resistors. These inputs must satisfy setup and hold times, t_{14} and t_{15} , for proper operation.

$\overline{\text{BLAST}}$

Burst Last (Active Low; Output)

$\overline{\text{BLAST}}$ indicates that the next time $\overline{\text{BRDY}}$ is returned, then the burst bus cycle is complete. $\overline{\text{BLAST}}$ is active for both burst and non-burst bus cycles. $\overline{\text{BLAST}}$ is active Low and is not driven during bus hold.

$\overline{\text{BOFF}}$

Backoff (Active Low; Input)

This input pin forces the Am486DX4 microprocessor to float its bus in the next clock. The microprocessor floats all pins normally floated during bus hold, but HLDA is not asserted in response to $\overline{\text{BOFF}}$. $\overline{\text{BOFF}}$ has higher priority than $\overline{\text{RDY}}$ or $\overline{\text{BRDY}}$; if both are returned in the same clock, $\overline{\text{BOFF}}$ takes effect. The microprocessor remains in bus hold until $\overline{\text{BOFF}}$ is negated. If a bus cycle is in progress when $\overline{\text{BOFF}}$ is asserted, the cycle is re-started. $\overline{\text{BOFF}}$ is active Low and must meet setup and hold times, t_{18a} and t_{19} , for proper operation.

BRDY**Burst Ready Input (Active Low; Input)**

This input pin performs the same cycle during a burst cycle that \overline{RDY} performs during a non-burst cycle. \overline{BRDY} indicates that the external system has presented valid data in response to a read or that the external system has accepted data in response to write. \overline{BRDY} is ignored when the bus is idle and at the end of the first clock in a bus cycle. \overline{BRDY} is sampled in the second and subsequent clocks of a burst cycle. The data presented on the data bus is strobed into the microprocessor when \overline{BRDY} is sampled active. If \overline{RDY} is returned simultaneously with \overline{BRDY} , \overline{BRDY} is ignored and the burst cycle is prematurely aborted. \overline{BRDY} is active Low and is provided with a small pull-up resistor. \overline{BRDY} must satisfy the setup and hold times, t_{16} and t_{17} .

BREQ**Internal Cycle Pending (Active High; Output)**

BREQ indicates that the Am486DX4 microprocessor has internally generated a bus request. BREQ is generated whether or not the Am486DX4 microprocessor is driving the bus. BREQ is active High and is never floated, except for three-state test mode (see **FLUSH**).

CLK**Clock (Input)**

CLK is a 1X clock providing the fundamental timing for the bus interface unit and is multiplied in accordance with the CLKMUL pin to provide the internal frequency for the Am486DX4 microprocessor. All external timing parameters are specified with respect to the rising edge of CLK.

CLKMUL**Clock Multiplier (Input)**

The clock multiplier input defines the ratio of internal core clock frequency to external bus frequency. If sampled Low, the core frequency operates at twice the external bus frequency (speed-double mode). If driven High or left floating speed-triple mode is selected. CLKMUL has an internal pull-up to V_{CC} and may be left floating in designs that wish to select speed-triple clock mode.

D31–D0**Data Lines (Inputs/Outputs)**

Lines D7–D0 define the least significant byte and lines D31–D24 define the most significant byte. These signals must meet setup and hold times t_{22} and t_{23} for proper operation on reads. The pins are driven during the second and subsequent write cycle clocks.

 $\overline{D/\overline{C}}$, $\overline{M/\overline{IO}}$, $\overline{W/\overline{R}}$ **Data/Control, Memory/Input/Output, Write/Read (Active High/Active Low; Output)**

These are the primary bus definition signals (in Table 2). These signals are driven valid as the \overline{ADS} signal is asserted. The bus definition signals are not driven during bus hold and follow the timing of the address bus.

The $\overline{D/\overline{C}}$ bus cycle definition pin distinguishes memory and I/O data cycles (D) from the control cycles (C): interrupt acknowledge, halt, and instruction fetching.

The $\overline{M/\overline{IO}}$ bus cycle definition pin distinguishes memory cycles (M) from input/output cycles (\overline{IO}).

The $\overline{W/\overline{R}}$ bus definition pin distinguishes write cycles from read cycles.

Table 2. Bus Cycle Definition

$\overline{M/\overline{IO}}$	$\overline{D/\overline{C}}$	$\overline{W/\overline{R}}$	Bus Cycle Initiated
0	0	0	Interrupt Acknowledge
0	0	1	Halt/Special Cycle
0	1	0	I/O Read
0	1	1	I/O Write
1	0	0	Code Read
1	0	1	Reserved
1	1	0	Memory Read
1	1	1	Memory Write

DP3–DP0**Data Parity (Active High; Inputs/Outputs)**

Data parity is generated on all write data cycles using the same timing as the data lines. Even parity information must be driven back into the microprocessor on the data parity pins with the same timing as read information. This process ensures that the correct parity check status is indicated. The signals read on these pins do not affect program execution. Input signals must meet setup and hold times, t_{22} and t_{23} . DP3–DP0 should be connected to V_{CC} through a pull-up resistor in systems not using parity. DP3–DP0 are active High and are driven during the second and subsequent clocks of write cycles.

 \overline{EADS} **Valid External Address (Active Low; Input)**

This pin indicates a valid external address has been driven onto the Am486DX4 microprocessor address pins. This address is used to perform an internal cache invalidation cycle. \overline{EADS} is active Low and is provided with an internal pull-up resistor. \overline{EADS} must satisfy setup and hold times, t_{12} and t_{13} , for proper operation.

 \overline{FERR} **Floating-Point Error (Active Low; Output)**

Driven active when a floating-point error occurs. \overline{FERR} is similar to the \overline{ERROR} pin on a 387 math coprocessor.

$\overline{\text{FERR}}$ is included for compatibility with systems using DOS-type floating-point error reporting. $\overline{\text{FERR}}$ is active Low, and is not floated during bus hold, except during three-state test mode (see $\overline{\text{FLUSH}}$).

FLUSH

Cache Flush (Active Low; Input)

$\overline{\text{FLUSH}}$ forces the Am486DX4 microprocessor to flush its entire internal cache. $\overline{\text{FLUSH}}$ is active Low and need only be asserted for one clock. $\overline{\text{FLUSH}}$ is asynchronous but setup and hold times, t_{20} and t_{21} , must be met for recognition in any specific clock. $\overline{\text{FLUSH}}$ being sampled Low in the clock before the falling edge of RESET causes the Am486DX4 microprocessor to enter the three-state test mode.

HLDA

Hold Acknowledge (Active High; Output)

HLDA goes active in response to a hold request presented on the HOLD pin. HLDA indicates that the Am486DX4 microprocessor has given the bus to another local bus master. HLDA is driven active in the same clock that the Am486DX4 microprocessor floats its bus. HLDA is driven inactive when leaving bus hold. HLDA is active High and remains driven during bus hold. HLDA is never floated except during three-state test mode (see $\overline{\text{FLUSH}}$).

HOLD

Bus Hold Request (Active High; Input)

This input pin allows another bus master complete control of the Am486DX4 microprocessor bus. In response to HOLD going active, the Am486DX4 microprocessor floats most of its output and input/output pins. HLDA is asserted after completing the current bus cycle, burst cycle, or sequence of locked cycles. The Am486DX4 microprocessor remains in this state until HOLD is deasserted. HOLD is active High and is not provided with an internal pull-down resistor. HOLD must satisfy setup and hold times t_{18} and t_{19} for proper operation.

IGNNE

Ignore Numeric Error (Active Low; Input)

When this pin is asserted, the Am486DX4 microprocessor will ignore a numeric error and continue executing non-control floating-point instructions. When $\overline{\text{IGNNE}}$ is deasserted, the Am486DX4 microprocessor will freeze on a non-control floating-point instruction if a previous floating-point instruction caused an error. $\overline{\text{IGNNE}}$ has no effect when the NE bit in Control Register 0 is set. $\overline{\text{IGNNE}}$ is active Low and is provided with a small internal pull-up resistor. $\overline{\text{IGNNE}}$ is asynchronous but must meet setup and hold times, t_{20} and t_{21} , to ensure recognition in any specific clock.

INTR

Maskable Interrupt (Active High; Input)

INTR indicates an external interrupt has been generated. If the internal interrupt flag is set in EFLAGS, active interrupt processing is initiated. The Am486DX4 microprocessor generates two locked interrupt acknowledge bus cycles in response to the INTR pin going active. INTR must remain active until the interrupt acknowledges have been performed. This ensures that the interrupt is recognized. INTR is active High and is not provided with an internal pull-down resistor. INTR is asynchronous, but must meet setup and hold times, t_{20} and t_{21} , for recognition in any specific clock.

KEN

Cache Enable (Active Low; Input)

$\overline{\text{KEN}}$ is used to determine whether the current cycle is cacheable. When the Am486DX4 microprocessor generates a cacheable cycle and $\overline{\text{KEN}}$ is active, the cycle becomes a cache line fill cycle. Returning $\overline{\text{KEN}}$ active one clock before $\overline{\text{RDY}}$ during the last read in the cache line fill causes the line to be placed in the on-chip cache. $\overline{\text{KEN}}$ is active Low and is provided with a small internal pull-up resistor. $\overline{\text{KEN}}$ must satisfy setup and hold times, t_{14} and t_{15} , for proper operation. LOCK

Bus Lock (Active Low; Output)

LOCK indicates the current bus cycle is locked. The Am486DX4 microprocessor does not allow a bus hold when LOCK is asserted (but address holds are allowed). LOCK goes active in the first clock of the first locked bus cycle and goes inactive after the last clock of the last locked bus cycle. The last locked cycle ends when $\overline{\text{RDY}}$ is returned. LOCK is active Low and is not driven during bus hold. Locked read cycles are not transformed into cache fill cycles if $\overline{\text{KEN}}$ is active.

NMI

Non-Maskable Interrupt (Active High; Input)

A high NMI signal indicates that external non-maskable interrupt occurred. NMI is rising edge sensitive, but must be held Low for at least four-CLK periods before the rising edge. NMI does not have an internal pull-down resistor. NMI is asynchronous, but must meet setup and hold times, t_{20} and t_{21} , for recognition in any specific clock.

PCD/PWT

Page Cache Disable/Page Write-Through (Active High; Outputs)

The outputs reflect the state of the page attribute bits, PWT and PCD, in the page table or page directory entry. If paging is disabled or unpagged cycles occur, PWT and PCD reflect the state of the PWT and PCD bits in Control Register 3. PWT and PCD have the same timing as the cycle definition pins ($\overline{\text{M}/\overline{\text{IO}}}$, $\overline{\text{D}/\overline{\text{C}}}$, and $\overline{\text{W}/\overline{\text{R}}}$). PWT and PCD are active High and are not driven during bus hold. PCD is masked by the Cache Disable Bit (CD) in Control Register 0.

PCHK**Parity Status (Active Low; Output)**

Parity status is driven on the $\overline{\text{PCHK}}$ pin the clock after $\overline{\text{RDY}}$ for read operations for data sampled at the end of the previous clock. A parity error is indicated by $\overline{\text{PCHK}}$ being Low. Parity status is only checked for enabled bytes as indicated by the byte enable and bus size signals. $\overline{\text{PCHK}}$ is valid only in the clock immediately after read data is returned to the microprocessor. At all other times $\overline{\text{PCHK}}$ is inactive High. $\overline{\text{PCHK}}$ is never floated except during three-state test mode (see $\overline{\text{FLUSH}}$).

PLOCK**Pseudo-Lock (Active Low; Output)**

$\overline{\text{PLOCK}}$ indicates that the current bus transaction requires more than one bus cycle to complete. Examples of such operations are floating-point long reads and writes (64 bits), segment table descriptor reads (64 bits), and cache line fills (128 bits). The Am486DX4 microprocessor drives $\overline{\text{PLOCK}}$ active until the addresses for the last bus cycle of the transaction have been driven, regardless of whether $\overline{\text{RDY}}$ or $\overline{\text{BRDY}}$ has been returned. Normally $\overline{\text{PLOCK}}$ and $\overline{\text{BLAST}}$ are inverse of each other. However, during the first bus cycle of a 64-bit floating-point write, both $\overline{\text{PLOCK}}$ and $\overline{\text{BLAST}}$ will be asserted. $\overline{\text{PLOCK}}$ is a function of the $\overline{\text{BS8}}$, $\overline{\text{BS16}}$, and $\overline{\text{KEN}}$ inputs. $\overline{\text{PLOCK}}$ should be sampled only if the clock $\overline{\text{RDY}}$ is returned. $\overline{\text{PLOCK}}$ is active Low and is not driven during bus hold.

RESET**Reset (Active High; Input)**

This pin forces the Am486DX4 microprocessor to begin execution at a known state. The microprocessor cannot begin execution of instructions until at least 1 ms after V_{CC} and CLK have reached their proper DC and AC specifications. The RESET pin should remain active during this time to ensure proper microprocessor operation. RESET is active High. RESET is asynchronous but must meet setup and hold times, t_{20} and t_{21} , for recognition in any specific clock.

 $\overline{\text{RDY}}$ **Non-Burst Ready (Active Low; Input)**

This input pin indicates that the current bus cycle is complete. $\overline{\text{RDY}}$ indicates that the external system has presented valid data on the data pins in response to a read, or that the external system has accepted data from the Am486DX4 microprocessor in response to a write. $\overline{\text{RDY}}$ is ignored when the bus is idle and at the end of the bus cycle's first clock.

$\overline{\text{RDY}}$ is active during address hold. Data can be returned to the processor while AHOLD is active.

$\overline{\text{RDY}}$ is active Low and is not provided with an internal pull-up resistor. $\overline{\text{RDY}}$ must satisfy setup and hold times, t_{16} and t_{17} , for proper chip operation.

TCK**Test Clock (Input)**

Test Clock is an input to the Am486DX4 CPU and provides the clocking function required by the JTAG boundary scan feature. TCK is used to clock state information and data into and out of the component. State select information and data are clocked into the component on the rising edge of TCK on TMS and TDI, respectively. Data is clocked out of the component on the falling edge of TCK on TDO.

TDI**Test Data Input (Input)**

TDI is the serial input used to shift JTAG instructions and data into the component. TDI is sampled on the rising edge of TCK, during the SHIFT-IR and the SHIFT-DR TAP controller states. During all other tap controller states, TDI is a "don't care."

TDO**Test Data Output (Output)**

TDO is the serial output used to shift JTAG instructions and data out of the component. TDO is driven on the falling edge of TCK during the SHIFT-IR and SHIFT-DR Test Access Port (TAP) controller states. At all other times, TDO is driven to the high-impedance state.

TMS**Test Mode Select (Input)**

TMS is decoded by the JTAG TAP to select the operation of the test logic. TMS is sampled on the rising edge of TCK. To guarantee deterministic behavior of the TAP controller, TMS is provided with an internal pull-up resistor.

 $\overline{\text{UP}}$ **Upgrade Present (Active Low; Input)**

The Upgrade Present pin forces the Am486DX4 CPU to three-state all its outputs and enter the power-down mode. When the Upgrade Present pin is sampled asserted by the CPU in the clock before the falling edge of RESET, the power-down mode is enabled. $\overline{\text{UP}}$ has no effect on the power-down status except during this edge. The CPU is also forced to three-state all of its outputs immediately in response to this signal. The $\overline{\text{UP}}$ signal must remain asserted in order to keep the pins three-state. $\overline{\text{UP}}$ is active Low and is provided with an internal pull-up resistor.

VOLDET**Voltage Detect (Active Low; Output)**

The voltage detect signal allows external system logic to distinguish between a 5-V Am486 processor and the 3.3-V Am486DX4 processor. The signal is active Low for a 3.3-V Am486DX4 processor.

Table 3. Output Pins

Name	Active Level	Floated At
BREQ	High	Three-State Test Mode
HLDA	High	Three-State Test Mode
BE3–BE0	Low	Bus Hold
PCD/PWT	High	Bus Hold
W/R, D/C, M/I \bar{O}	High	Bus Hold
LOCK	Low	Bus Hold
PLOCK	Low	Bus Hold
ADS	Low	Bus Hold
BLAST	Low	Bus Hold
PCHK	Low	Three-State Test Mode
A3–A2	High	Bus, Address Hold
FERR	Low	Three-State Test Mode
VOLDET	Low	–

Table 4. Input Pins

Name	Active Level	Synchronous/Asynchronous
CLK	–	–
RESET	High	Asynchronous
HOLD	High	Synchronous
AHOLD	High	Synchronous
EADS	Low	Synchronous
BOFF	Low	Synchronous
FLUSH	Low	Asynchronous
A20M	Low	Asynchronous
BS16, BS8	Low	Synchronous
KEN	Low	Synchronous
RDY	Low	Synchronous
BRDY	Low	Synchronous
INTR	High	Asynchronous
NMI	High	Asynchronous
UP	Low	Asynchronous
IGNNE	Low	Asynchronous
CLKMUL	–	–

Table 5. Input/Output Pins

Name	Active Level	Floated At
D31–D0	High	Bus Hold
DP3–DP0	High	Bus Hold
A31–A4	High	Bus, Address Hold

Table 6. Test Pins

Name	Input or Output	Sampled/Driven On
TCK	Input	N/A
TDI	Input	Rising Edge of TCK
TDO	Output	Falling Edge of TCK
TMS	Input	Rising Edge of TCK

CPU IDENTIFICATION CODES

The DX register always contains a component identification at the conclusion of RESET. The upper byte of DX (DH) contains 04 and the lower byte of DX (DL) contains a CPU type/stepping identifier.

Table 7. CPU ID

Component ID (DH)	Component ID (DL)
04	32

Table 8. JTAG ID Code

Version Code	Part Number Code	Manufacturer Identity
00h	0432	01

ARCHITECTURAL OVERVIEW

The Am486DX4 processor is a 32-bit architecture with on-chip memory management and cache memory units. It is a fully compatible member of the Am486 Family.

On-chip cache memory allows frequently used data and code to be stored on-chip, thereby reducing accesses to the external bus. A clock multiplier has been added to speed up internal operations. RISC design techniques are used to reduce instruction cycle times. A burst bus feature enables fast cache fills.

The Am486 CPU Memory Management Unit (MMU) consists of a segmentation unit and a paging unit. Segmentation allows management of the logical address space by providing easy data and code relocatability and efficient sharing of global resources. The paging mechanism operates beneath segmentation and is transparent to the segmentation process. Paging is optional and can be disabled by system software. Each segment can be divided into one or more 4-Kbyte segments. To implement a virtual memory system, the Am486DX4 microprocessor supports full restartability for all page and segment faults.

Memory is organized into one or more variable length segments, each up to 4 Gbyte (2^{32} bytes) in size. A segment can have attributes associated with it. These

attributes include its location, size, type (i.e., stack, code, or data), and protection characteristics. Each task on an Am486DX4 microprocessor can have a maximum of 16,381 segments, each up to 4 Gbyte in size. Thus, each task has a maximum of 64 Tbyte (terabytes) of virtual memory.

The segmentation unit provides four levels of protection for isolating and protecting applications and the operating system from each other. The hardware enforced protection allows high integrity system designs.

The Am486DX4 microprocessor has three modes of operation: Real Address Mode (Real Mode), Virtual Address Mode (Protected Mode), and within Protected Mode, tasks may be performed in Virtual 8086 Mode. In Real Mode, the Am486DX4 microprocessor operates as a very fast 8086. Real Mode is required primarily to set up the processor for Protected Mode operation. Protected Mode provides access to the sophisticated memory management paging and privilege capabilities of the processor.

Within Protected Mode, software can perform a task switch to enter into tasks designated as Virtual 8086 Mode tasks. Each Virtual 8086 task behaves with 8086 semantics, allowing 8086 software (an application program or an entire operating system) to execute.

The on-chip cache is 8 Kbyte. It is four-way set associative and follows a write-through policy. The on-chip cache includes features that provide flexibility in external memory system design. Individual pages can be designated as cacheable or non-cacheable by software or hardware. The cache can also be enabled and disabled by software or hardware.

Finally, the Am486DX4 microprocessor has features that facilitate high-performance hardware designs. The clock multiplier improves execution performance without increasing the board design complexity. This clock multiplier enhances all operations operating out of the cache and/or not blocked by external bus accesses. The burst bus feature enables fast cache fills.

ELECTRICAL DATA

The following sections describe recommended electrical connections for the Am486DX4 microprocessor and its electrical specifications.

Power and Grounding

Power Connections

The Am486DX4 CPU is implemented in 0.5 micron CMOS 3-layer metal technology and has modest power requirements. However, its high clock frequency output buffers can cause power surges as multiple output buffers drive new signal levels simultaneously. For clean, on-chip power distribution at high frequency, 23 V_{CC} and 28 V_{SS} pins feed the Am486DX4 microprocessor.

Power and ground connections must be made to all external V_{CC} and GND pins of the Am486DX4 microprocessor. On the circuit board, all V_{CC} pins must be connected on a V_{CC} plane. All V_{SS} pins must likewise be connected on a GND plane.

Power Decoupling Recommendations

Liberal decoupling capacitance should be placed near the Am486DX4 microprocessor. The Am486DX4 microprocessor, driving its 32-bit parallel address and data buses at high frequencies, can cause transient power surges, particularly when driving large capacitive loads.

Low inductance capacitors and interconnects are recommended for best high-frequency electrical performance. Inductance can be reduced by shortening circuit board traces between the Am486DX4 CPU, and decoupling capacitors as much as possible. Capacitors specifically for PGA packages are also commercially available.

System Clock Recommendations

The CLK input to the Am486DX4 processor should not be driven until V_{CC} has reached its normal operating level (3.3 V). Once V_{CC} has reached its normal operating level, the Am486DX4 CPU can handle the clock frequency for which it is specified and the oscillator/clock driver should have locked onto its desired frequency.

Other Connection Recommendations

NC pins should always remain unconnected.

For reliable operation, always connect unused inputs to an appropriate signal level. Active Low inputs should be connected to V_{CC} through a pull-up resistor. Pull-ups in the range of 20 $K\Omega$ are recommended. Active High inputs should be connected to GND.

INC is electrically isolated and has no special requirements.

ABSOLUTE MAXIMUM RATINGS

Case Temperature under Bias -65°C to +110°C
 Storage Temperature -65°C to +150°C
 Voltage on any pin
 with respect to ground -0.5 V to $V_{CC} + 2.6$ V
 Supply voltage with
 respect to V_{SS} -0.5 V to +4.6 V

Stresses above those listed under Absolute Maximum Ratings may cause permanent device failure. Functionality at or above these limits is not implied. Exposure to Absolute Maximum Ratings for extended periods may affect device reliability.

OPERATING RANGES**Commercial (C) Devices**

T_{CASE} 0°C to +85°C
 V_{CC} 3.3 V \pm 0.3 V

Operating Ranges define those limits between which the functionality of the device is guaranteed.

DC CHARACTERISTICS over COMMERCIAL operating ranges

Functional Operating Range: $V_{CC} = 3.3$ V \pm 0.3 V; $T_{CASE} = 0^\circ$ C to +85°C.

Symbol	Parameter Description	Notes	Preliminary		Unit
			Min	Max	
V_{IL}	Input Low Voltage		-0.3	+0.8	V
V_{IH}	Input High Voltage		2.0	$V_{CC} + 2.4$	V
V_{OL}	Output Low Voltage	I_{OL} =(Note 1)		0.45	V
V_{OH}	Output High Voltage	I_{OH} =(Note 2)	2.4		V
I_{CC}	Power Supply Current	100 MHz (Note 3) 120 MHz (Note 3)		1000 1200	mA
I_{LI}	Input Leakage Current	(Note 4) (Note 8)		± 15 ± 50	μ A
I_{IH}	Input Leakage Current	(Note 5)		200	μ A
I_{IL}	Input Leakage Current	(Note 6)		-400	μ A
I_{LO}	Output Leakage Current	(Note 9) (Note 10)		± 15 ± 50	μ A
C_{IN}	Input Capacitance	$F_C = 1$ MHz (Note 7)		10	pF
C_{OUT}	I/O or Output Capacitance	$F_C = 1$ MHz (Note 7)		14	pF
C_{CLK}	CLK Capacitance	$F_C = 1$ MHz (Note 7)		12	pF

Notes:

- This parameter is measured at: Address, Data, $\overline{BE3}$ – $\overline{BE0}$ 4.0 mA
Definition, Control 5.0 mA
- This parameter is measured at: Address, Data, $\overline{BE3}$ – $\overline{BE0}$ -1.0 mA
Definition, Control -0.9 mA
- Typical supply current: 800 mA @ 100 MHz or 960 mA @ 120 MHz
- This parameter is for inputs without pull-ups or pull-downs and $0 \leq V_{IN} \leq V_{CC}$.
- This parameter is for inputs with pull-downs and $V_{IH} = 2.4$ V.
- This parameter is for inputs with pull-ups and $V_{IL} = 0.45$ V.
- Not 100% tested.
- This parameter is for inputs without pull-ups or pull-downs and $V_{CC} \leq V_{IN} \leq 5$ V.
- This parameter is for three-state outputs where V_{EXT} is driven on the three-state output and $0 \leq V_{EXT} \leq V_{CC}$.
- This parameter is for three-state outputs where V_{EXT} is driven on the three-state output and $V_{CC} \leq V_{EXT} \leq 5$ V.

SWITCHING CHARACTERISTICS

The switching characteristics consist of output delays, input setup requirements, and input hold requirements. All switching characteristics are relative to the rising edge of the CLK signal.

The switching characteristics measurements are defined by Figures 2–9. Inputs must be driven to the voltage levels indicated by Figure 2 when switching characteristics are measured.

Am486DX4 microprocessor output delays are specified with minimum and maximum limits. The minimum Am486DX4 microprocessor delay times are hold times provided to external circuitry. Am486DX4 microprocessor input setup and hold times are specified as minimums, defining the smallest acceptable sampling windows. Within the sampling windows, a synchronous input signal must be stable for correct Am486DX4 microprocessor operation.

SWITCHING CHARACTERISTICS over COMMERCIAL operating rangesOperating Frequency/Bus Frequency: 120/40MHz; $T_{CASE}=0^{\circ}C$ to $+85^{\circ}C$; $C_L=50$ pF unless otherwise specified.

Symbol	Parameter Description	Notes	Figure	Preliminary		Unit
				Min	Max	
	Operating Frequency			8	40	MHz
t_1	CLK Period		2	25	125	ns
t_{1a}	CLK Period Stability	Adjacent Clocks			0.1%	Δ
t_2	CLK High Time	@ 2.0 V	2	9		ns
t_3	CLK Low Time	@ 0.8 V	2	9		ns
t_4	CLK Fall Time		2		3	ns
t_5	CLK Rise Time		2		3	ns
t_6	A31–A2, PWT, PCD, M/I \bar{O} , $\overline{BE3}$ – $\overline{BE0}$, D/ \bar{C} , W/R, \overline{ADS} , \overline{LOCK} , \overline{FERR} , BREQ, HLDA Valid Delay		7	3	14	ns
t_7	A31–A2, PWT, PCD, M/I \bar{O} , $\overline{BE3}$ – $\overline{BE0}$, D/ \bar{C} , W/R, \overline{ADS} , \overline{LOCK} , \overline{FERR} , BREQ, HLDA Float Delay	(Note 1)	8	3	18	ns
t_8	\overline{PCHK} Valid Delay		6	3	16	ns
t_{8a}	\overline{BLAST} , \overline{PLOCK} Valid Delay		7	3	18	ns
t_9	\overline{BLAST} , \overline{PLOCK} Float Delay	(Note 1)	8	3	16	ns
t_{10}	D31–D0, DP3–DP0 Write Data Valid Delay		7	3	16	ns
t_{11}	D31–D0, DP3–DP0 Write Data Float Delay	(Note 1)	8	3	18	ns
t_{12}	\overline{EADS} Setup Time		4	5		ns
t_{13}	\overline{EADS} Hold Time		4	3		ns
t_{14}	\overline{KEN} , $\overline{BS16}$, $\overline{BS8}$ Setup Time		4	5		ns
t_{15}	\overline{KEN} , $\overline{BS16}$, $\overline{BS8}$ Hold Time		4	3		ns
t_{16}	\overline{RDY} , \overline{BRDY} Setup Time		5	5		ns
t_{17}	\overline{RDY} , \overline{BRDY} Hold Time		5	3		ns
t_{18}	HOLD, AHOLD Setup Time		4	6		ns
t_{18a}	\overline{BOFF} Setup Time		4	8		ns
t_{19}	HOLD, AHOLD, \overline{BOFF} Hold Time		4	3		ns
t_{20}	RESET, \overline{FLUSH} , $\overline{A20M}$, NMI, INTR, \overline{IGNNE} Setup Time		3, 4	5		ns
t_{21}	RESET, \overline{FLUSH} , $\overline{A20M}$, NMI, INTR, \overline{IGNNE} Hold Time		3, 4	3		ns
t_{22}	D31–D0, DP3–DP0, A31–A4 Read Setup Time		4, 5	5		ns
t_{23}	D31–D0, DP3–DP0, A31–A4 Read Hold Time		4, 5	3		ns

Note:

1. Not 100% tested. Guaranteed by design characterization.

Operating Frequency/Bus Frequency: 100/33 MHz; $T_{CASE}=0^{\circ}C$ to $+85^{\circ}C$; $C_L=50$ pF unless otherwise specified.

Symbol	Parameter Description	Notes	Figure	Preliminary		Unit
				Min	Max	
	Operating Frequency			8	33	MHz
t_1	CLK Period		2	30	125.5	ns
t_{1a}	CLK Period Stability	Adjacent Clocks			0.1%	Δ
t_2	CLK High Time	@ 2.0 V	2	11		ns
t_3	CLK Low Time	@ 0.8 V	2	11		ns
t_4	CLK Fall Time		2		3	ns
t_5	CLK Rise Time		2		3	ns
t_6	A31–A2, PWT, PCD, M/I \bar{O} , BE3–BE0, D/C, W/R, ADS, LOCK, FERR, BREQ, HLDA Valid Delay		7	3	14	ns
t_7	A31–A2, PWT, PCD, M/I \bar{O} , BE3–BE0, D/C, W/R, ADS, LOCK, FERR, BREQ, HLDA Float Delay	(Note 1)	8		20	ns
t_8	PCHK Valid Delay		6	3	14	ns
t_{8a}	BLAST, PLOCK Valid Delay		7	3	14	ns
t_9	BLAST, PLOCK Float Delay	(Note 1)	8		20	ns
t_{10}	D31–D0, DP3–DP0 Write Data Valid Delay		7	3	14	ns
t_{11}	D31–D0, DP3–DP0 Write Data Float Delay	(Note 1)	8		20	ns
t_{12}	EADS Setup Time		4	5		ns
t_{13}	EADS Hold Time		4	3		ns
t_{14}	KEN, BS16, BS8 Setup Time		4	5		ns
t_{15}	KEN, BS16, BS8 Hold Time		4	3		ns
t_{16}	RDY, BRDY Setup Time		5	5		ns
t_{17}	RDY, BRDY Hold Time		5	3		ns
t_{18}	HOLD, AHOLD Setup Time		4	6		ns
t_{18a}	BOFF Setup Time		4	7		ns
t_{19}	HOLD, AHOLD, BOFF Hold Time		4	3		ns
t_{20}	RESET, FLUSH, A20M, NMI, INTR, I \bar{GNNE} Setup Time		3, 4	5		ns
t_{21}	RESET, FLUSH, A20M, NMI, INTR, I \bar{GNNE} Hold Time		3, 4	3		ns
t_{22}	D31–D0, DP3–DP0, A31–A4 Read Setup Time		4, 5	5		ns
t_{23}	D31–D0, DP3–DP0, A31–A4 Read Hold Time		4, 5	3		ns

Note:

1. Not 100% tested. Guaranteed by design characterization.



Am486DX4 CPU AC Characteristics for Boundary Scan Test Signals at 25 MHz

$V_{CC} = 3.3 \text{ V} \pm 0.3 \text{ V}$; $T_{CASE} = 0^{\circ}\text{C}$ to $+85^{\circ}\text{C}$; $C_L = 50 \text{ pF}$. All inputs and outputs are TTL Level.

Symbol	Parameter	Min	Max	Unit	Figure	Notes
t ₂₄	TCK Frequency		25	MHz		1X Clock
t ₂₅	TCK Period	40		ns	9	Note 2
t ₂₆	TCK High Time	10		ns		at 2.0 V
t ₂₇	TCK Low Time	10		ns		at 0.8 V
t ₂₈	TCK Rise Time		4	ns		Note 1
t ₂₉	TCK Fall Time		4	ns		Note 1
t ₃₀	TDI, TMS Setup Time	8		ns	9	Note 3
t ₃₁	TDI, TMS Hold Time	7		ns	9	Note 3
t ₃₂	TDO Valid Delay	3	25	ns	9	Note 3
t ₃₃	TDO Float Delay		30	ns	9	Note 3
t ₃₄	All Outputs (Non-Test) Valid Delay	3	25	ns	9	Note 3
t ₃₅	All Outputs (Non-Test) Float Delay		36	ns	9	Note 3
t ₃₆	All Inputs (Non-Test) Setup Time	8		ns	9	Note 3
t ₃₇	All Inputs (Non-Test) Hold Time	7		ns	9	Note 3

Notes:

1. Rise/Fall times are measured between 0.8 V and 2.0 V. Rise/Fall times can be relaxed by 1 ns per 10-ns increase in TCK period.
2. TCK period \geq CLK period.
3. Parameter measured from TCK.

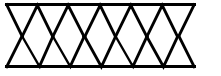
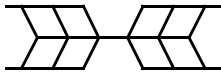
WAVEFORM	INPUTS	OUTPUTS
	Must be Steady	Will be Steady
	May Change from H to L	Will be Changing from H to L
	May Change from L to H	Will be Changing from L to H
	Don't Care, Any Change Permitted	Changing, State Unknown
	Does Not Apply	Center Line is High-Impedance "Off" State

KS00000

Figure 1. Change State Diagram

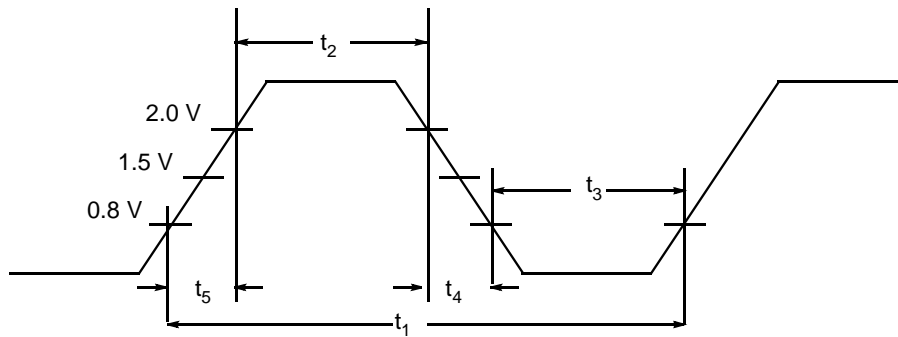

17852B-095

Figure 2. CLK Waveforms

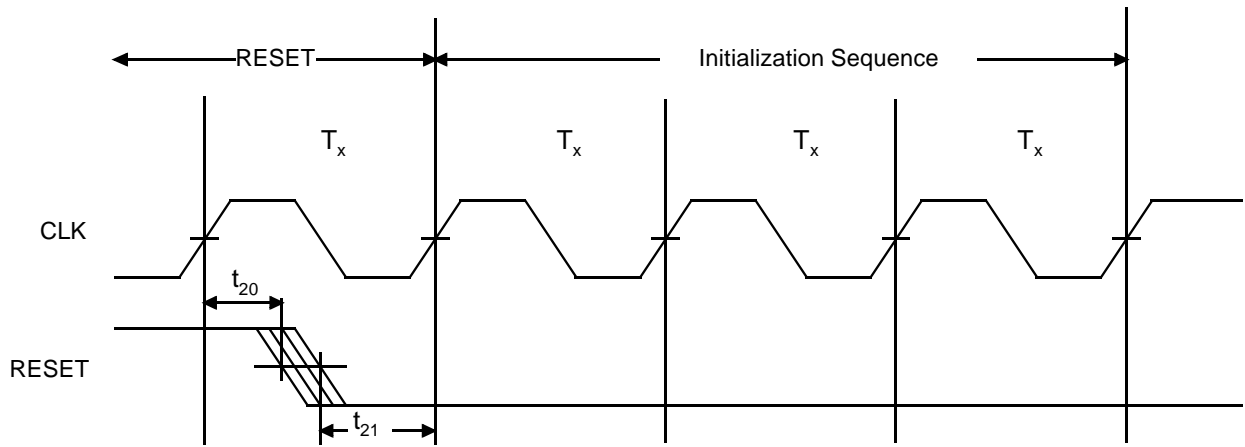

19160c.003

Figure 3. Reset Setup and Hold Timing

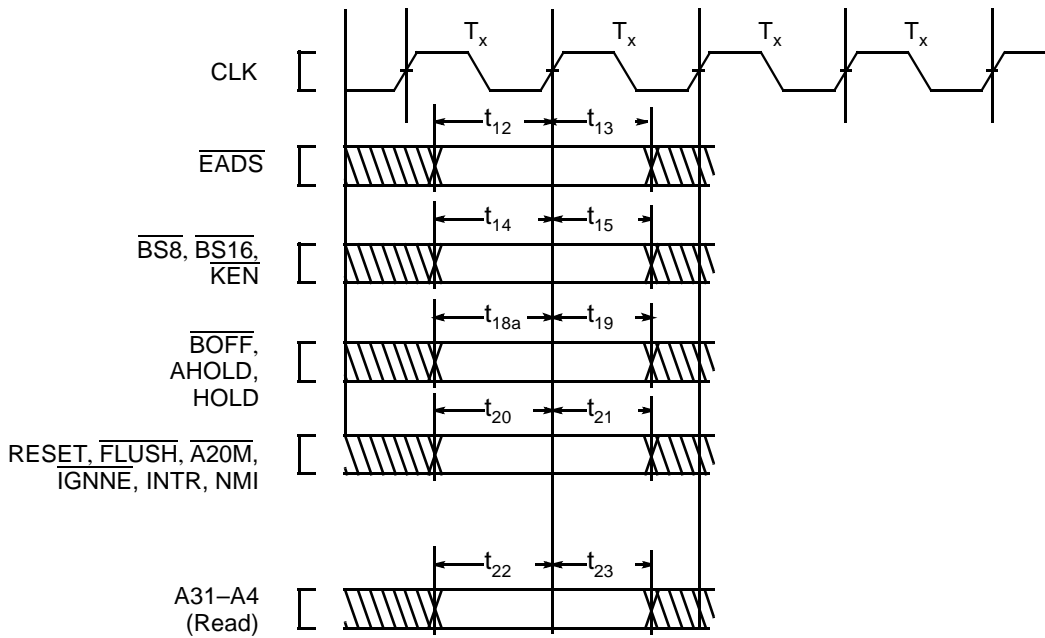

19160c.004

Figure 4. Input Setup and Hold Timing

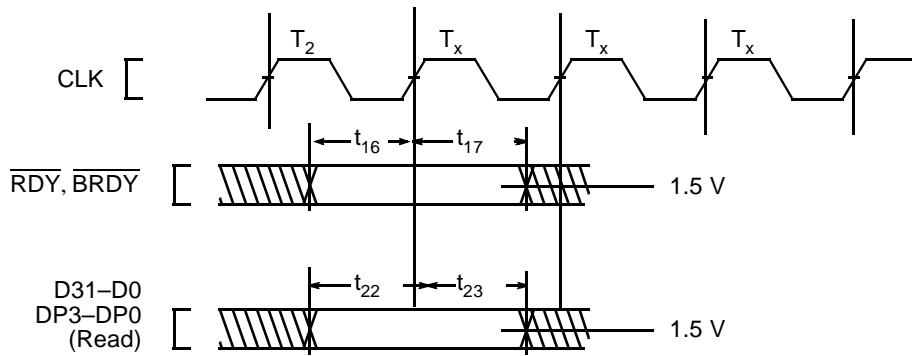

19160c.005

Figure 5. RDY and BRDY Input Setup and Hold Timing

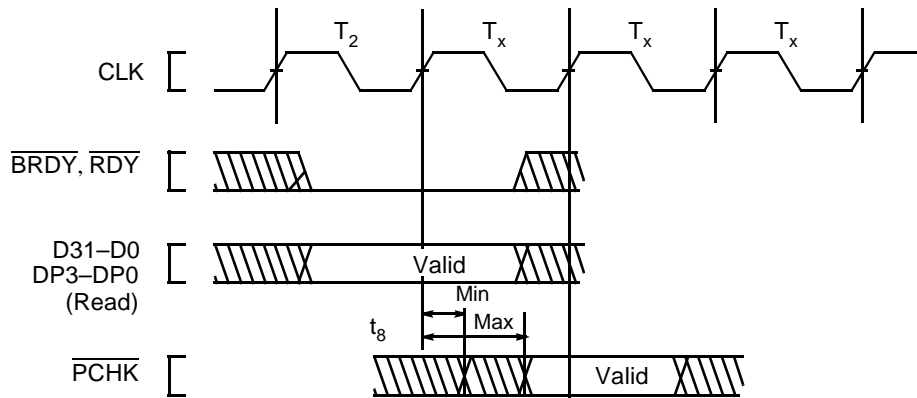

19160c.006

Figure 6. PCHK Valid Delay Timing

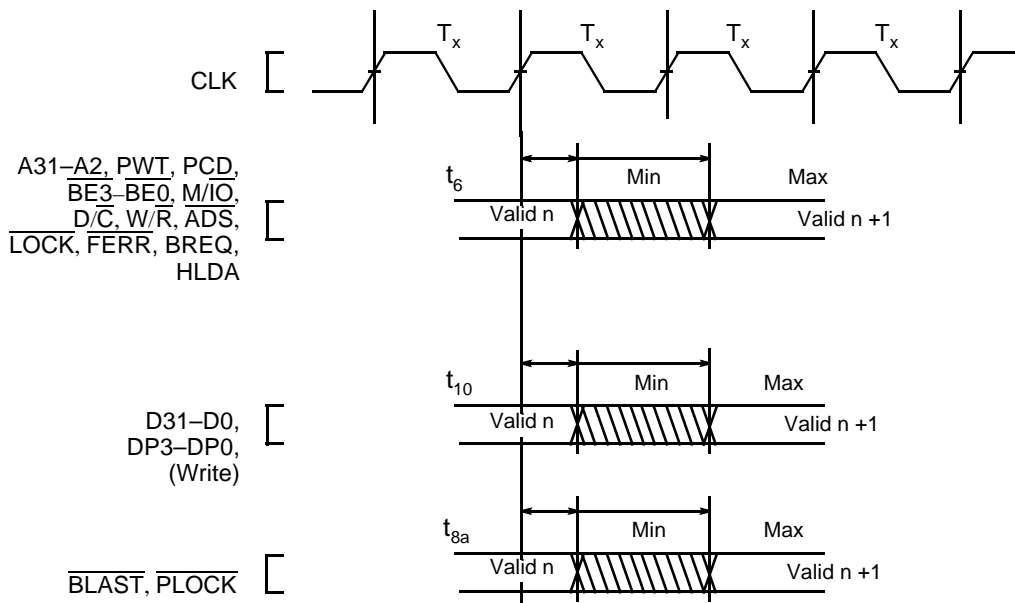

19160c.007

Figure 7. Output Valid Delay Timing

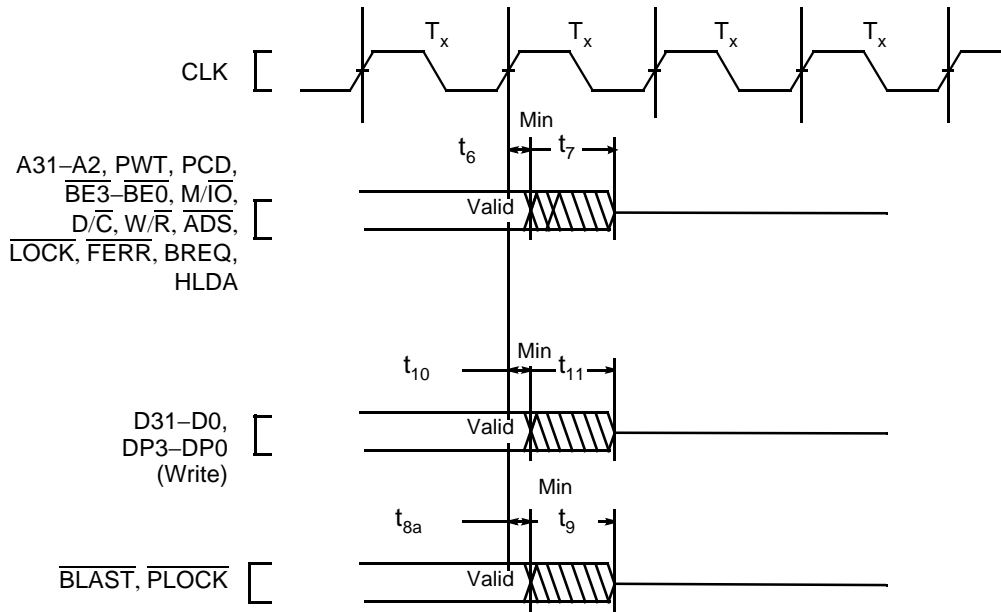

17852A-103

Figure 8. Maximum Float Delay Timing

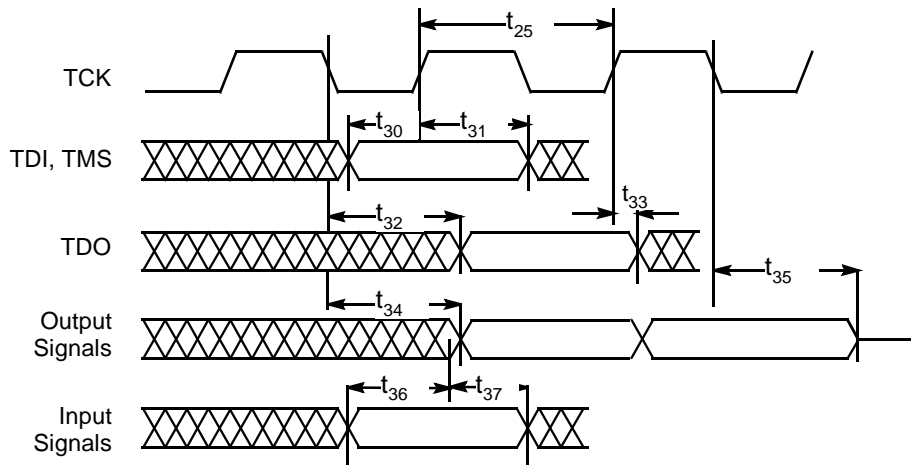

17852B-104

Figure 9. Test Signal Timing Diagram

Package Thermal Specifications

The Am486DX4 microprocessor is specified for operation when T_{CASE} (the case temperature) is within the range of 0°C to +85°C. T_{CASE} can be measured in any environment to determine whether the Am486DX4 microprocessor is within specified operating range. The case temperature should be measured at the center of the top surface opposite the pins.

The ambient temperature (T_A) is guaranteed as long as T_{CASE} is not violated. The ambient temperature can be calculated from θ_{JC} and θ_{JA} and from the following equations:

$$T_J = T_{CASE} + P \cdot \theta_{JC}$$

$$T_A = T_J - P \cdot \theta_{JA}$$

$$T_{CASE} = T_A + P \cdot [\theta_{JA} - \theta_{JC}]$$

where:

T_J, T_A, T_{CASE} = Junction, Ambient, and Case Temperature.

θ_{JC}, θ_{JA} = Junction-to-Case and Junction-to-Ambient Thermal Resistance, respectively.

P = Maximum Power Consumption

The values for θ_{JA} and θ_{JC} are given in Table 9 for the 1.75 sq. in., 168-pin, ceramic PGA.

Table 10 shows the T_A allowable (without exceeding T_{CASE}) at various airflows and operating frequencies (Clock). Note that T_A is greatly improved by attaching fins or a heat sink to the package. Heat sink dimensions are shown in Figure 10. P (the maximum power consumption) is calculated by using the maximum I_{CC} at 3.3 V as tabulated in the *DC Characteristics*.

Table 9. Thermal Resistance (°C/W) θ_{JC} and θ_{JA} for the 168-Pin, Ceramic PGA Package

	θ_{JC}	θ_{JA} vs. Airflow-ft/min. (m/sec)					
		0 (0)	200 (1.01)	400 (2.03)	600 (3.04)	800 (4.06)	1000 (5.07)
No Heat Sink	1.5	16.5	14.0	12.0	10.5	9.5	9.0
Heat Sink*	2.0	12.0	7.0	5.0	4.0	3.5	3.25
Heat Sink* and fan	2.0	5.0	4.6	4.2	3.8	3.5	3.25

*0.350" high unidirectional heat sink (Al alloy 6063-T5, 40 mil fin width, 155 mil center-to-center fin spacing).

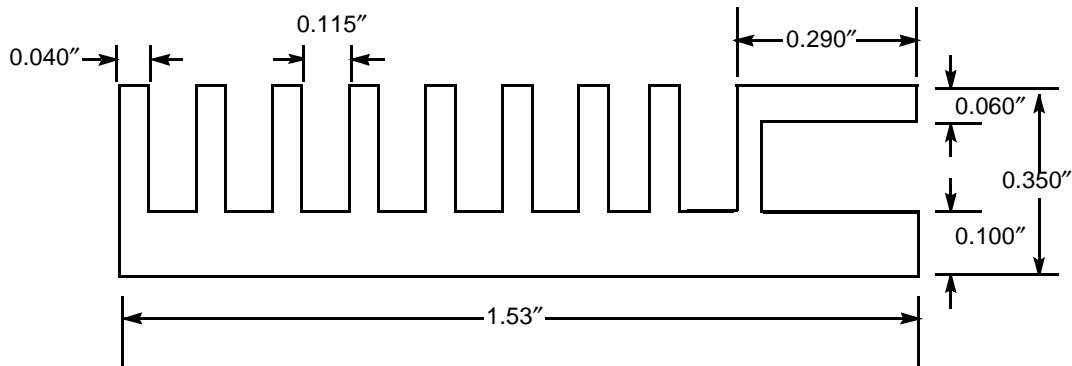

Figure 10. Heat Sink Dimensions

17852B-113

Table 10. Maximum T_A at Various Airflows in °C

	Clock	Airflow-ft/min. (m/sec)					
		0 (0)	200 (1.01)	400 (2.03)	600 (3.04)	800 (4.06)	1000 (5.07)
T_A —No Heat Sink	100 MHz	31.0	41.8	49.0	54.4	58.0	59.8
T_A —Heat Sink	100 MHz	49.0	67.0	74.2	77.8	79.6	80.5
	120 MHz	41.8	63.4	72.0	76.4	78.5	79.6
T_A —Heat Sink and fan	100 MHz	74.2	75.6	77.1	78.5	79.6	80.5
	120 MHz	72.0	73.8	75.5	77.2	78.5	79.6

PHYSICAL DIMENSIONS

For reference only. All dimensions are measured in inches. BSC is an ANSI standard for Basic Space Centering.

CGM 168

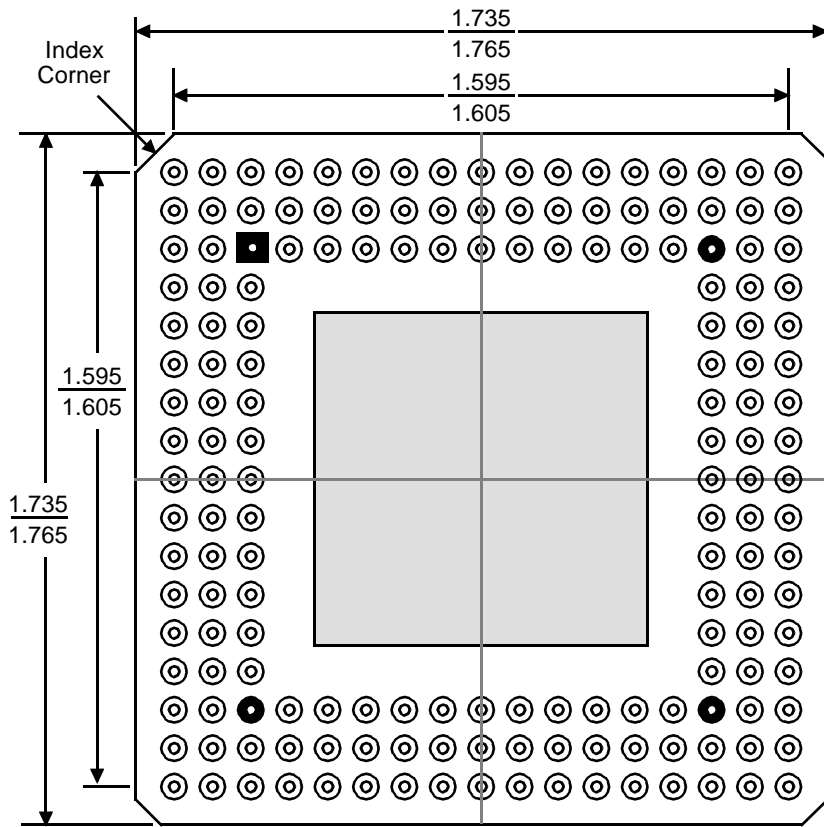

Bottom View (Pins Facing Up)

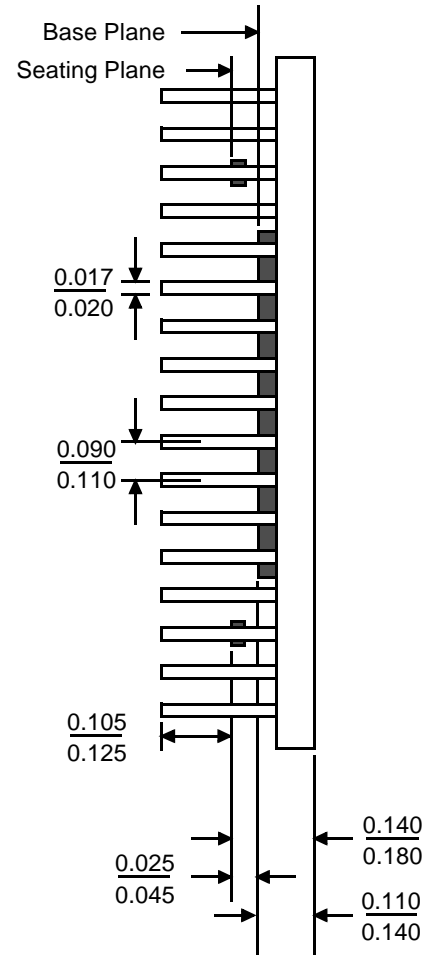

Side View

16734C

5/11/93 MH

AMD, Am386, and Am486 are registered trademarks of Advanced Micro Devices, Inc.
 FusionPC is a service mark of Advanced Micro Devices, Inc.
 Microsoft and Windows are registered trademarks of Microsoft Corp.

Product names used in this publication are for identification purposes only and may be trademarks of their respective companies.

