

# MB3U, MB3U-I2C

## BiSS TO PC-USB ADAPTER



Rev B2, Page 1/7

### ORDERING INFORMATION

Type	Order Designation	Description Options
PC Adpater	iC-MB3 iCSY MB3U	BiSS to PC-USB Adapter
	iC-MB3 iCSY MB3U-I2C	BiSS and I2C to PC-USB Adapter
	iC-MB3 iCSY MB3U-PS230	BiSS to PC-USB Adapter including wall power supply (230VAC to 12 V; 400 mA)
	iC-MB3 iCSY MB3U-I2C-PS230	BiSS and I2C to PC-USB Adapter including wall power supply (230VAC to 12 V; 400 mA)
Software	BiSS GUI	GUI software for Windows PC communication to BiSS PC Adapter
	MB3U USB DRIVER	USB device driver (Windows ME/2000/XP/Vista - ready) please see <a href="http://www.ichaus.com">www.ichaus.com</a> for download information Scope of delivery: USB AB cable (1 m)

### DESCRIPTION

The *BiSS* to PC-USB Adapter enables *BiSS* or SSI sensors to be connected to a PC easily and at low cost. The USB port supplies the adapter as well as the connected sensor, for which the 5V (up to 50 mA, through Pin 4)\* and 12 V (up to 90 mA, through Pin 1)\* as galvanically isolated voltages are available. An external wall power supply can also be connected to deliver other voltages or higher currents. The *BiSS*/SSI communication is accomplished by differential RS422 wires with separate potentials and cycle rates of up to 10 Mbit/sec.

#### Technical Data *BiSS* Interface

- Synchronously triggered measurement data collection from up to 3 *BiSS* sensors or one SSI encoder
- *BiSS* data rates up to 10 Mbit/sec., SSI up to 4 Mbit/sec.
- Protocol compatible with *BiSS* Master iC-MB3z
- USB 2.0 compatible
- Galvanic encoder signal isolation
- Galvanically isolated sensor supply sourced from the USB port (+12 V / 90 mA, +5 V / 50 mA)\*
- Plug-in power supply can be connected for sensors with higher power needs

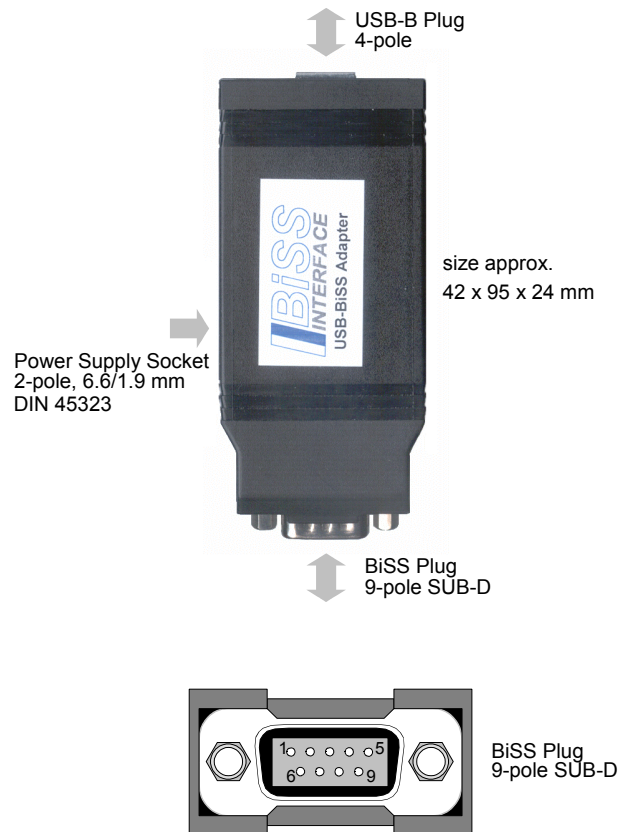

Figure 1: iC-MB3 iCSY MB3U

\* 100 mA for +5 V and +12 V available starting from 2008

# MB3U, MB3U-I2C

## BiSS TO PC-USB ADAPTER



Rev B2, Page 2/7

### BiSS Plug Pin Configuration

Pin	Name	Function
1	VB	+12 V Sensor supply (90 mA <sub>max</sub> )* Optional: powered by ext. supply
2	MA +	Clock output P
3	MA -	Clock output N
4	VDD	+5 V Sensor supply (50 mA <sub>max</sub> )*
5	MO -	+5 V High-level signal Optional: master data output N
6	GND	Ground (0 V)
7	SL +	Data input P
8	SL -	Data input N
9	MO +	0 V Low-level signal Optional: master data output P

### Power Supply Socket

Inner contact	Negative pole
Outer contact	Pos. pole (9 to 15 V DC, 1 A <sub>max</sub> )

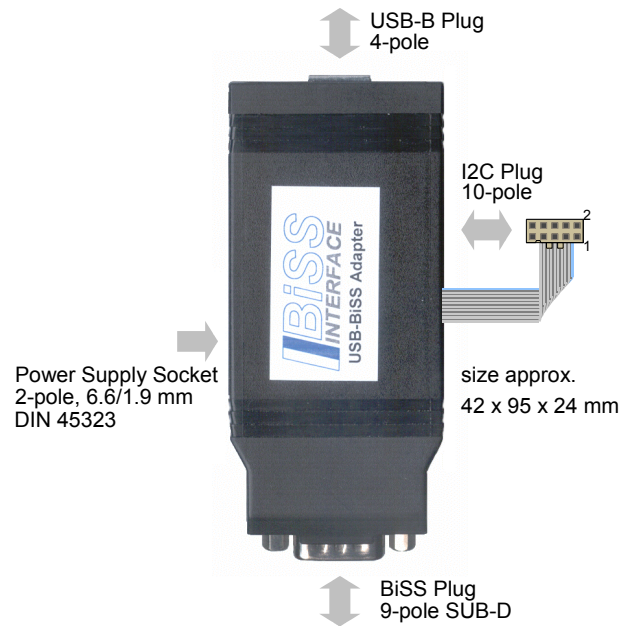

Figure 2: iC-MB3 iCSY MB3U-I2C

### PC-USB Adapter With I2C Extension

The *BiSS* and I2C to PC-USB Adapter has an additional plug for I2C or SPI communication. The USB port supplies the sensors via the I2C plug with 5 V (up to 250 mA, through Pin 4 - no galvanic isolation). If there is load applied to the *BiSS* connector, the maximum current supplied via the I2C plug is decreased. For more power, an additional external power supply is recommended (the wall power supply does not supply the I2C plug, see Figure 3). I2C multi-master capability is not provided.

### Technical Data I2C / SPI Interface

- Serial computer bus communication I2C
- Serial computer bus communication SPI
- Sensor supply sourced from the USB port (+5 V up to 250 mA) without isolation
- I2C data rates of up to 320 kHz
- USB 2.0 compatible

### I2C Plug Pin Configuration For I2C-Link

PIN	Name	Function
1	SCL	Serial Clock Line
2	GND	Ground
3	-	Reserved
4	+5 V	Supply Voltage
5	-	Reserved
6	-	Reserved
7	SDA	Serial Data Line
8	-	Reserved
9	SDA	Serial Data Line
10	GND	Ground

**Note:** To use I2C, pin 7 and pin 9 must be short.

### I2C Plug Pin Configuration For SPI-Link

PIN	Name	Function
1	SCLK	Serial Clock
2	GND	Ground
3	-	Reserved
4	+5 V	Supply Voltage
5	-	Reserved
6	-	Reserved
7	MOSI	Master Out Slave IN
8	NCS	Not Chip Select
9	MISO	Master In Slave Out
10	GND	Ground

\* 100 mA for +5 V and +12 V available starting from 2008

# MB3U, MB3U-I2C

## BiSS TO PC-USB ADAPTER



Rev B2, Page 3/7

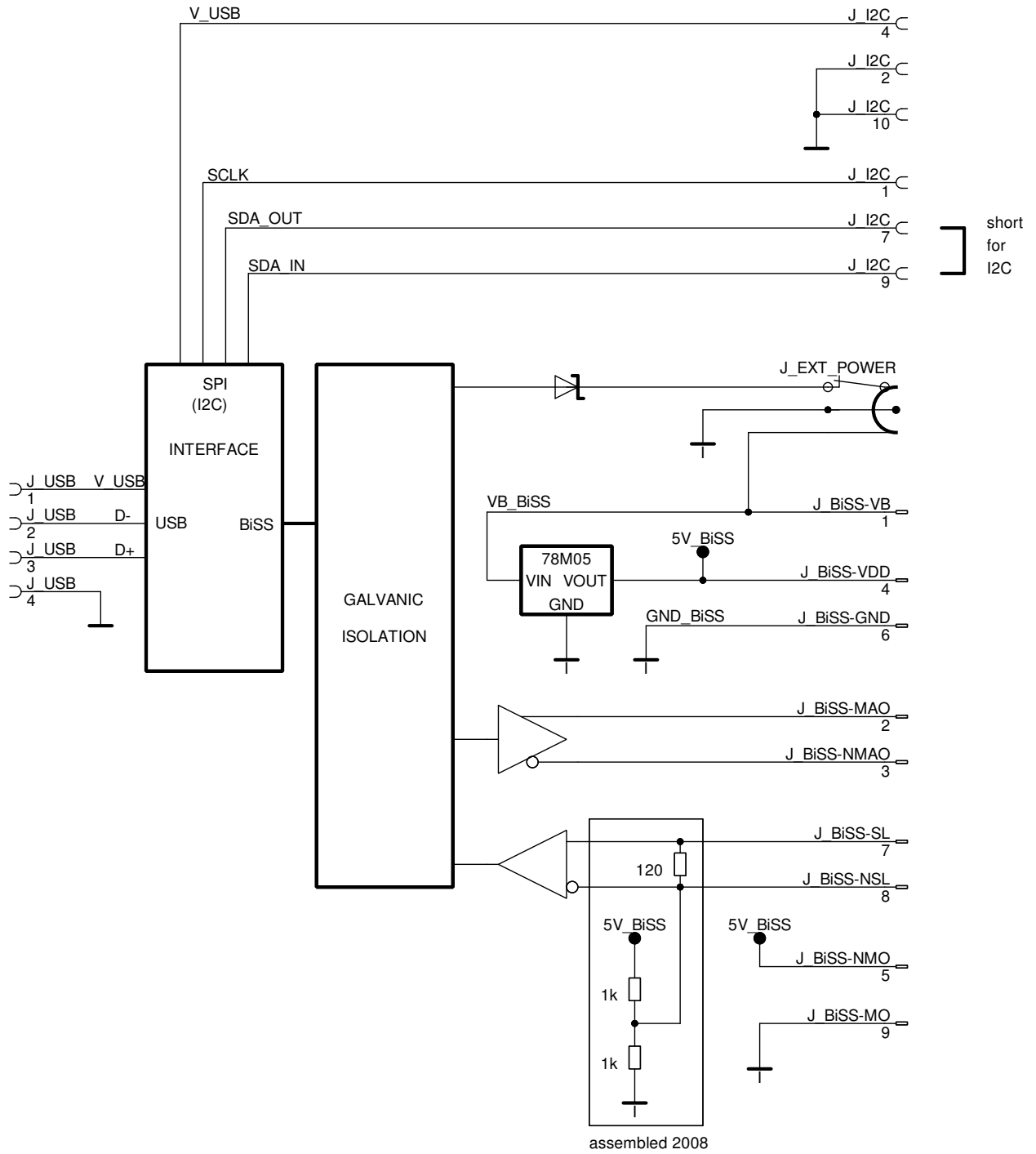

Figure 3: Power supply routing of MB3U-I2C

### APPLICATION SOFTWARE

BiSS software for PCs running on Windows operating systems, as well as the required USB driver are available as a ZIP file. Download from <http://www.ichaus.de/product.php?prod=MB3A/MB3U>

#### Installation

After unzipping the "BiSS\_xx.zip", the following files are located in the selected directory.

(xx is a placeholder for revisions)

- BiSS\_xx.msi
- mb3u\_usb\_driver.exe
- mb3\_lpt\_driver.exe
- readme.txt

**Note:** Administrator rights are required to run installation.

1. The installation of the software starts by executing the "BiSS\_xx.msi" installation package. Follow the on-screen instructions to finish the installation procedure.
2. USB driver need to be installed to access the BiSS PC Adapter. Execute the mb3u\_usb\_driver.exe installation package and follow the on-screen instructions. This process can take a few minutes.
3. Installation will make the software "BiSS\_xx.exe" available in the selected working directory. The execution of this file will start the software. Figure 4 shows a screenshot of the start up window.

File "idbiss6943.xml" is a BiSS device description file for BiSS slave ICs of iC-Haus. Please contact the manufacturer of your sensor for an appropriate device description file or set the transmission parameters yourself later.

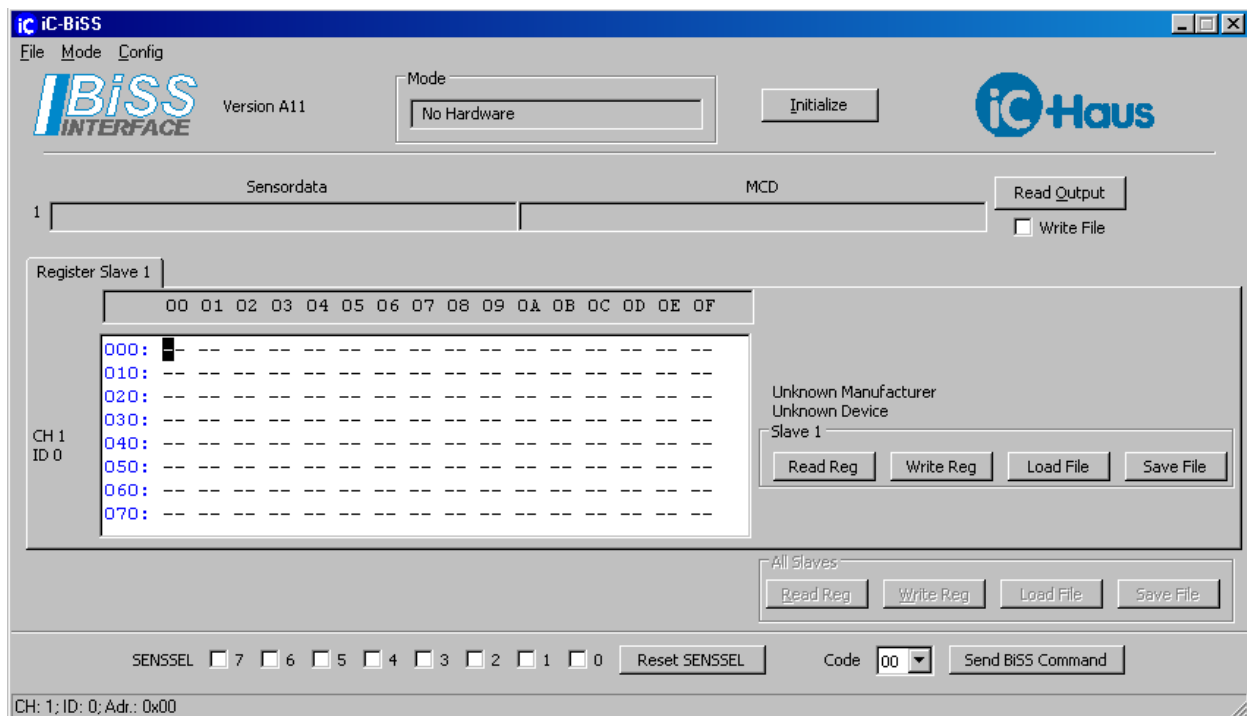

Figure 4: Screenshot

### Instructions

Before connecting the *BiSS* adapter to the PC please make sure you have installed the latest USB driver!

Connect the adapter via the USB AB cable and start the "BiSS\_xx.exe". Select the USB operating mode. The display in the "Mode" description field should show "MB3U (MB3Z)" - the adapter is now ready to operate.

### Sensor-specific settings

To set the *BiSS* Master for the sensor(s) connected to it, select **Config Slaves** and manually configure the *BiSS* parameters (data lengths, CRC polynomials, etc.) according to the sensor's data sheet. If there is a *BiSS* device description file from the sensor manufacturer in the working directory (iC-Haus example: "idbiss6943.xml"), you can use **Auto Config**. You will receive a message such as **BiSS-Identifier** "Slave 1: Manufacturer iC-Haus GmbH, Device iC-NQX2; Resolution=1024, 0 Bits period counter as sensor data!".

### Configuration files

Transmission parameter settings can be stored to a \*.cfg file for later use with the "BiSS\_xx" software. "Save BiSS-Master-Config" writes an *BiSS* Master Chip configuration description into a \*.txt file (e. g. setup of iC-MB3).

### Main causes for errors:

- Using more than one software.  
→ Please make sure that only one software is accessing the *BiSS* MB3U adapter at the same time.
- Insufficient power supply for all sensors attached.  
→ The adapter will not respond if there is an overload due to the sensor(s) connected. Please use the wall power supply.
- Invalid transmission parameter settings.  
→ Please check the sensor specific *BiSS* slave parameters, such as CRC polynomial etc.

### Description of Menu Section

	Button	Description
<File>	Load Config-File	Loads <i>BiSS</i> transmission parameter settings from file
	Save Config-File	Writes <i>BiSS</i> transmission parameter settings to file
	Save BiSS-Master-Config	Writes an interface configuration description to file
	Exit	Quit software
<Mode>	No Hardware	Switch to no hardware to terminate PC to adapter communication
	Intel-Mode (MB3D-P)	For use with <i>BiSS</i> PC-LPT evaluation board (MB3D)
	Motorola-Mode (MB3D-P)	For use with <i>BiSS</i> PC-LPT evaluation board (MB3D)
	SPI-Mode (MB3D-S / MB3A)	For use with <i>BiSS</i> PC-LPT adapter MB3A, eval board MB3D-S
	USB-SPI-Mode (MB3U)	For use with <i>BiSS</i> PC-USB adapter MB3U
<Config>	Config BiSS	<i>BiSS</i> bus communication settings
	Config Slaves	<i>BiSS</i> transmission parameter settings
	Show Sensor Data Window	Enables separate window to display sensor data

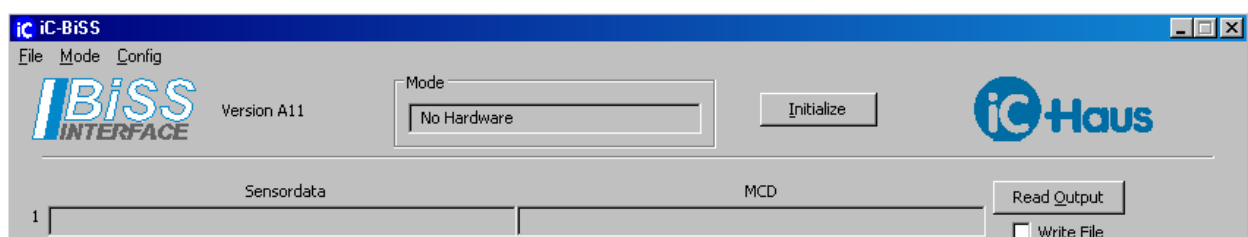

Figure 5: Upper section

Button	Description
Initialize	Initializes <i>BiSS</i> bus after configurations are made
Read Output	Reads in sensor data
Write File	Saves sensor data to file

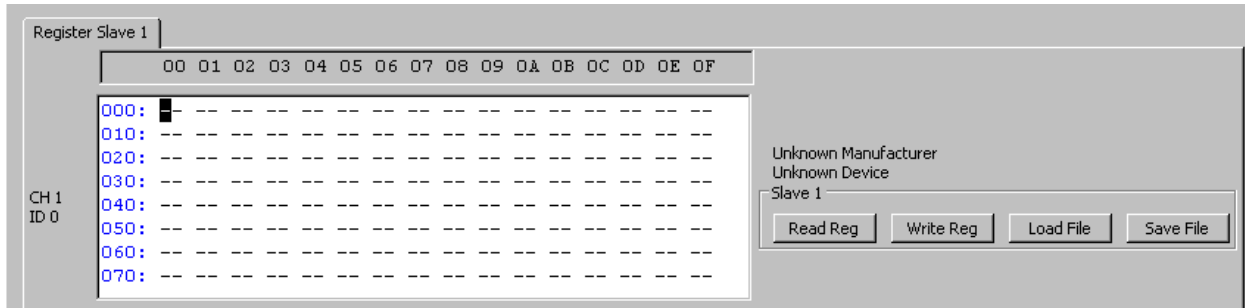

Figure 6: **Middle section** (one tab each per slave)

Button	Description
Read Reg	Loads register configuration from sensors to software GUI (hex)
Write Reg	Transfers the displayed register configuration to sensors (hex)
Load File	Loads register configuration from a file (hex)
Save File	Saves register configuration to a file (hex)

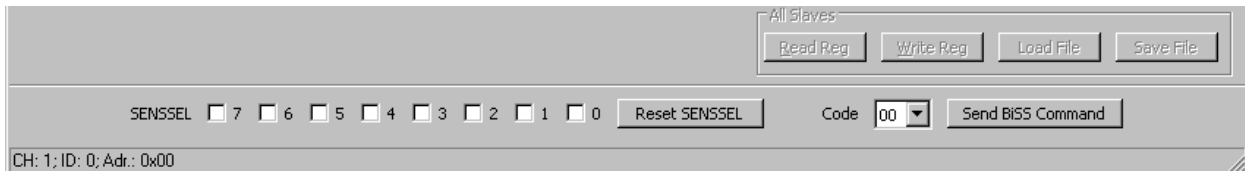

Figure 7: **Lower section** (valid for all slaves)

Button	Description
Read Reg	see Middle Section
Write Reg	see Middle Section
Load File	see Middle Section
Save File	see Middle Section
SENSEL	Mask for slave selection. For broadcast please select none
Reset SENSEL	Clears all SENSEL checkboxes
Code	<i>BiSS</i> command selection
Send BiSS Command	Sends the chosen command to the selected slaves

# MB3U, MB3U-I2C

## BiSS TO PC-USB ADAPTER



Rev B2, Page 7/7

### REVISION HISTORY

Rev	Notes	Pages affected
A4	Previous release	
A5	Update of MB3U technical data, MB3U-I2C, software description	all
A6	Update of MB3U-I2C optional SPI interface functionality	all
B1	iC-MB3 iCSY MB3U-PS230 and iC-MB3 iCSY MB3U-I2C-PS230 added	1
	Scope of delivery: wall power supply removed	1
B2	BiSS Plug Pin Configuration table format updated	2
	"I2C Plug Pin Configuration For I2C" header updated	2
	"I2C Plug Pin Configuration For SPI" header updated	2
	"100 mA for +5 V and +12 V available starting from 2008" added	2

iC-Haus expressly reserves the right to change its products and/or specifications. An Infoletter gives details as to any amendments and additions made to the relevant current specifications on our internet website [www.ichaus.de/infoletter](http://www.ichaus.de/infoletter); this letter is generated automatically and shall be sent to registered users by email.

Copying – even as an excerpt – is only permitted with iC-Haus approval in writing and precise reference to source.

iC-Haus does not warrant the accuracy, completeness or timeliness of the specification on this site and does not assume liability for any errors or omissions in the materials. The data specified is intended solely for the purpose of product description. No representations or warranties, either express or implied, of merchantability, fitness for a particular purpose or of any other nature are made hereunder with respect to information/specification or the products to which information refers and no guarantee with respect to compliance to the intended use is given. In particular, this also applies to the stated possible applications or areas of applications of the product.

iC-Haus conveys no patent, copyright, mask work right or other trade mark right to this product. iC-Haus assumes no liability for any patent and/or other trade mark rights of a third party resulting from processing or handling of the product and/or any other use of the product.

As a general rule our developments, IPs, principle circuitry and range of Integrated Circuits are suitable and specifically designed for appropriate use in technical applications, such as in devices, systems and any kind of technical equipment, in so far as they do not infringe existing patent rights. In principle the range of use is limitless in a technical sense and refers to the products listed in the inventory of goods compiled for the 2008 and following export trade statistics issued annually by the Bureau of Statistics in Wiesbaden, for example, or to any product in the product catalogue published for the 2007 and following exhibitions in Hanover (Hannover-Messe).

We understand suitable application of our published designs to be state-of-the-art technology which can no longer be classed as inventive under the stipulations of patent law. Our explicit application notes are to be treated only as mere examples of the many possible and extremely advantageous uses our products can be put to.