

Silicon Image

PanelLink[®]
Technology

Si1 164
PanelLink Transmitter

Data Sheet

Document # Si1-DS-0021-D.doc

Silicon Image, Inc.

SiI-DS-0021-D
September 2002

Application Information

To obtain the most updated Application Notes and other useful information for your design, please visit the Silicon Image web site at www.siliconimage.com or contact your local Silicon Image sales office.

Copyright Notice

This manual is copyrighted by Silicon Image, Inc. Do not reproduce, transform to any other format, or send/transmit any part of this documentation without the expressed written permission of Silicon Image, Inc.

Trademark Acknowledgment

Silicon Image, the Silicon Image logo, PanelLink[®] and the PanelLink[®] Digital logo are registered trademarks of Silicon Image, Inc. TMDS[™] is a trademark of Silicon Image, Inc. VESA[®], FPD[™] are trademarks of the Video Electronics Standards Association. I²C is a trademark of Philips Semiconductor. All other trademarks are the property of their respective holders.

Disclaimer

This document provides technical information for the user. Silicon Image, Inc. reserves the right to modify the information in this document as necessary. The customer should make sure that they have the most recent data sheet version. Silicon Image, Inc. holds no responsibility for any errors that may appear in this document. Customers should take appropriate action to ensure their use of the products does not infringe upon any patents. Silicon Image, Inc. respects valid patent rights of third parties and does not infringe upon or assist others to infringe upon such rights.

All information contained herein is subject to change without notice.

Revision History

Revision	Date	Comment
SiI-DS-0021-A	01/99	Full Release
SiI-DS-0021-B	03/99	Internal Revision B release
SiI-DS-0021-C	04/02	New format. I ² C programming and strapping mode description, TFT mapping and Design Recommendations, pin names ISEL/RST changed to ISEL/RST# and PD to PD#.
SiI-DS-0021-D	09/02	Included Pb-free package. Added De-skew range. Corrected PD# pin number.

© 2002 Silicon Image, Inc.

TABLE OF CONTENTS

General Description	1
Features	1
SiI 164 Pin Diagram	1
Functional Description	2
PanelLink TMDS Digital Core	2
I ² C Interface and Registers	2
Data Capture Logic	3
Electrical Specifications	4
Absolute Maximum Conditions	4
Normal Operating Conditions	4
Digital I/O Specifications	4
DC Specifications	5
AC Specifications	6
Input Timing Diagrams	7
Pin Descriptions	9
Input Pins	9
Configuration Pins	10
Input Voltage Reference Pin	11
Power Management Pins	11
Differential Signal Data Pins	11
Reserved Pins	11
Power and Ground Pins	11
I ² C Registers	12
I ² C Register Mapping	12
I ² C Register Definitions	13
I ² C Slave Interface and Address	15
Data De-skew Feature	16
Data Latching Modes	17
I ² C Programming Sequence	18
Enabling Hot Plug Detection Mode	18
Non I ² C Mode Configuration	19
TFT Panel Data Mapping	21
Design Recommendations	24
1.5V to 3.3V I ² C Bus Level-Shifting	24
Voltage Ripple Regulation	25
Decoupling Capacitors	26
Series Damping Resistors on Outputs	27
Differential Trace Routing	27
Package Dimensions and Marking Specification	29
Ordering Information	29

LIST OF TABLES

Table 1. Data De-Skew Estimated Values	16
Table 2. Sample Programming Sequence for SiI 164.....	18
Table 3. Non I ² C Strapping Mode Options	20
Table 4. One Pixel/Clock Input/Output TFT Mode - VESA P&D and FPDI-2™ Compliant.....	21
Table 5. 24-bit One Pixel/Clock Input with 24-bit Two Pixels/Clock Output TFT Mode	22
Table 6. 18-bit One Pixel/Clock Input with 18-bit Two Pixels/Clock Output TFT Mode	23
Table 7. Recommended Components for Bypass and Decoupling Circuits	26

LIST OF FIGURES

Figure 1. Pin Diagram for SiI 164	1
Figure 2. Functional Block Diagram.....	2
Figure 3. Clock Cycle High/Low Times	7
Figure 4. Low Swing Differential Times	7
Figure 5. ISEL/RST# Minimum Timing	7
Figure 6. Input Data Setup/Hold Time to IDCK.....	8
Figure 7. VSYNC, HSYNC and CTL[3:1] Delay Time from DE.....	8
Figure 8. DE High and Low Times	8
Figure 9. I ² C Data Valid Delay (driving Read Cycle data).....	8
Figure 10. I ² C Byte Read	15
Figure 11. I ² C Byte Write	15
Figure 12. SiI 164 Data De-skew Feature Timing.....	16
Figure 13. 12 bit Input Data Latching.....	17
Figure 14. 24 bit Input Data Latching.....	17
Figure 15. Non I ² C Mode Schematic Example	19
Figure 16. I ² C Bus Voltage Level-Shifting using Fairchild NDC7002N	24
Figure 17. I ² C Bus Voltage Level Shifting using Philips GTL 2010.....	24
Figure 18. Voltage Regulation using TL431.....	25
Figure 19. Voltage Regulation using LM317	25
Figure 20. Decoupling and Bypass Capacitor Placement	26
Figure 21. Decoupling and Bypass Schematic	26
Figure 22. Series Input Damping Resistors for Driving Source	27
Figure 23. Example of Incorrect Differential Signal Routing.....	27
Figure 24. Example of Correct Differential Signal Routing	28
Figure 25. Differential Trace Routing to DVI Connector(Top Side View)	28
Figure 26. 64-pin TQFP Package Dimensions (JEDEC code MS-026ED)	29

General Description

The Sil 164 transmitter uses PanelLink® Digital technology to support displays ranging from VGA to UXGA resolutions (25 - 165Mpps) in a single link interface.

The Sil 164 transmitter has a highly flexible interface with either a 12-bit mode (½ pixel per clock edge) or 24-bit mode 1 pixel per clock edge input for true color (16.7 million) support. In 24-bit mode, the Sil 164 supports single or dual edge clocking. In 12-bit mode, the Sil164 supports dual edge single clocking or single edge dual clocking. The Sil 164 can be programmed through an I²C interface. In addition the Sil 164 also supports Receiver and Hot Plug Detection.

PanelLink Digital technology simplifies PC design by resolving many of the system level issues associated with high-speed mixed signal design, providing the system designer with a digital interface solution that is quicker to market and lower in cost.

Features

- Scaleable Bandwidth: 25 - 165MHz Flexible
- Graphics Controller Interface: 12-bit or 24-bit mode 1 pixel/clock inputs
- Flexible Input Clocking: Single clock single edge (24-bit), Single clock dual edge (12-/24-bit), Dual clock single edge (12-bit)
- I²C Slave Programming Interface up to 100kHz
- Low Voltage Interface: 3.3V with option for 1.0 to 3.0V Low Voltage Signal Mode
- Monitor Detection supported through hot plug and receiver detection
- De-skewing Option varies input clock to input data timing
- Low Power: 3.3V operation (120mA max.) and Power Down mode (1mA max.)
- Cable Distance Support: over 5m with twisted pair and fiber-optics ready
- Compliant with DVI 1.0 (DVI is backwards compliant with VESA® P&D™ and DFP)
- Standard and Pb-free packages (see pg 29)

Sil 164 Pin Diagram

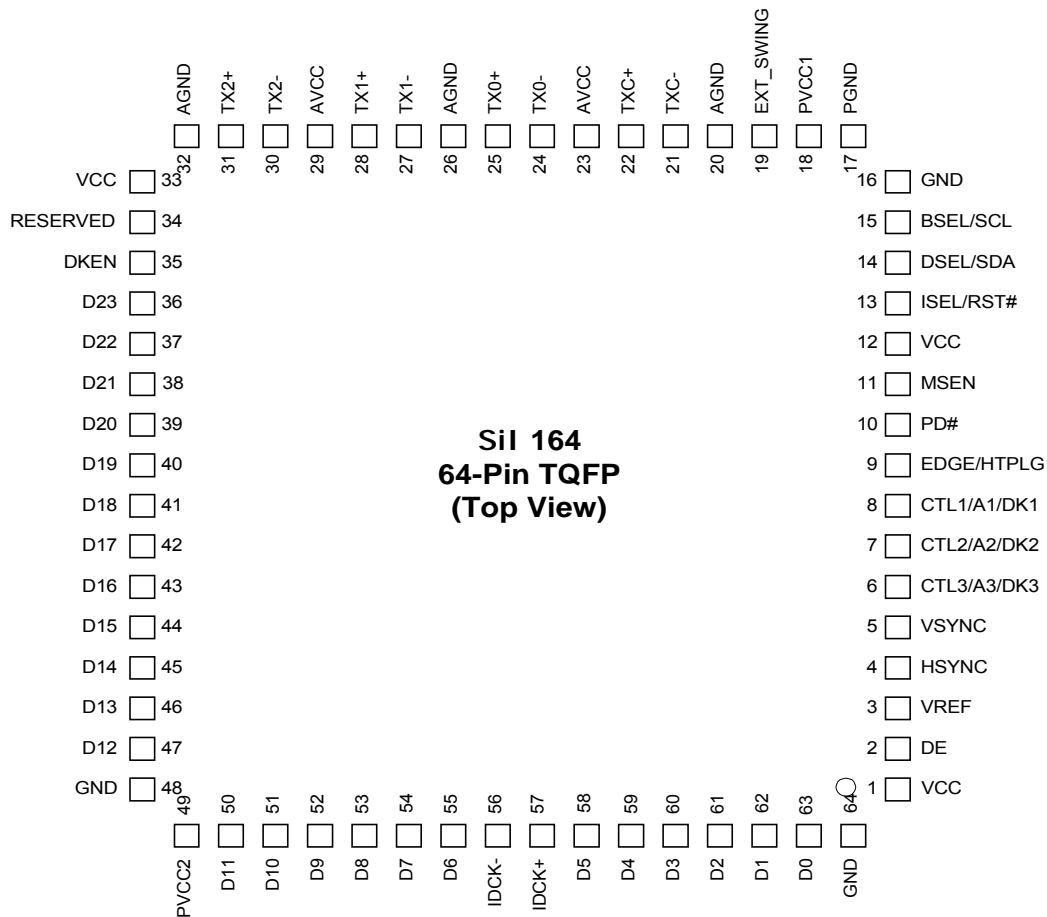

Figure 1. Pin Diagram for Sil 164

Functional Description

The SiI 164 is a DVI 1.0 compliant PanelLink transmitter in a compact package. It provides 24 bits for data Input to allow for panel support up to UXGA resolution. Figure 2 shows the functional blocks of the chip.

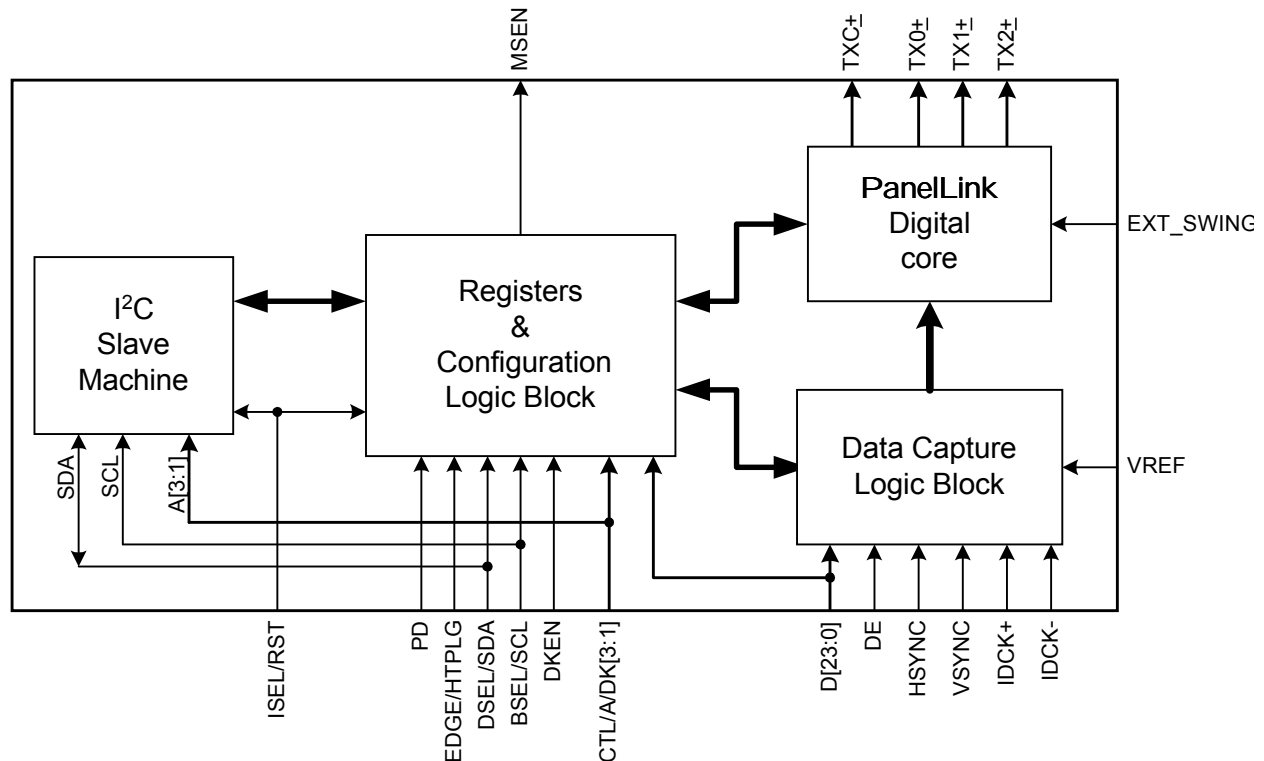

Figure 2. Functional Block Diagram

PanelLink TMDS Digital Core

The PanelLink TMDS core encodes video information onto three TMDS differential data lines and the differential clock. The video data is input by the Data Capture Logic Block, as a 12- or 24-bit bus, using one or two clocks with one or two edges per clock. An attached monitor may be sensed using the HTPLG pin or internally with Receiver Sense. This detected state may be output onto the MSEN pin. The device may be powered down using the PD# pin or with an internal register. The SiI 164 is reset using the ISEL/RST# pin. A resistor tied to the EXT_SWING pin is used to control the TMDS swing amplitude.

I²C Interface and Registers

The SiI 164 uses a slave I²C interface, capable of running at 100kHz. The slave I²C interface is not 5V tolerant. If the switching levels from the host are not 3.3V, then a voltage level shifter must be used. See Figure 16 and Figure 17 on page 24 for a system diagram.

A connected display may be detected using the DVI Hot Plug signal, attached to the HTPLG pin; or with the Receiver Sense logic internal to the SiI 164. The state of the detection, or an interrupt signal indicating a change of state, may be sent to the MSEN pin. This is useful to the host controller monitoring the SiI 164.

Data Capture Logic

Video data is input to the SiI 164 by way of a 12-bit or 24-bit interface. The functionality of this interface is affected by several of the configuration register settings, as follows.

- BSEL selects between 12-bit and 24-bit input bus widths.
- DSEL selects between single-edge and dual-edge modes for the input clocks.
- EDGE selects between rising and falling edge on the input clocks.
- CLK+ and CLK- provide the one or two clocks required for latching the input data bus.
- The PD# input selects the chip power down mode and allows for disabling of the TMDS outputs.

The ISEL/RST# input resets the HDCP engine and internal registers and is asserted after power up and receipt of a stable input pixel clock.

Electrical Specifications

Absolute Maximum Conditions

Absolute Maximum Conditions are defined as the worst case conditions the part will tolerate without sustaining damage. Permanent device damage may occur if absolute maximum conditions are exceeded. Proper operation under these conditions is not guaranteed. Functional operation should be restricted to the conditions described under Normal Operating Conditions.

Symbol	Parameter	Min	Typ	Max	Units
V_{CC}	Supply Voltage 3.3V	-0.3		4.0	V
V_I	Input Voltage	-0.3		$V_{CC} + 0.3$	V
V_O	Output Voltage	-0.3		$V_{CC} + 0.3$	V
T_J	Junction Temperature (with power applied)			125	°C
T_{STG}	Storage Temperature	-65		150	°C

Normal Operating Conditions

Symbol	Parameter	Min	Typ	Max	Units
V_{CC}	Supply Voltage	3.0	3.3	3.6	V
V_{CCN}	Supply Voltage Noise			100	mV _{P-P}
T_A	Ambient Temperature (with power applied)	0	25	70	°C
θ_{JA}	Thermal Resistance (Junction to Ambient) ¹			64	°C/W

Note

1. Airflow at 0m/s.

Digital I/O Specifications

Under normal operating conditions unless otherwise specified.

Symbol	Parameter	Conditions	Min	Typ	Max	Units
V_{IH}	High Swing High-level Input Voltage	$V_{REF} = V_{CC}$	2.0			V
V_{IL}	High Swing Low-level Input Voltage	$V_{REF} = V_{CC}$			0.8	V
V_{DDQ}^2	Low Swing Voltage		1		3.0	V
V_{SH}	Low Swing High-level Input Voltage	$V_{REF} = V_{DDQ}/2$	$V_{DDQ}/2 + 300mV$			V
V_{SL}	Low Swing Low-level Input Voltage	$V_{REF} = V_{DDQ}/2$			$V_{DDQ}/2 - 100mV$	V
V_{CINL}	Input Clamp Voltage ¹	$I_{CL} = -18mA$			GND -0.8	V
V_{CIPL}	Input Clamp Voltage ¹	$I_{CL} = 18mA$			$V_{CC} + 0.8$	V
I_{IL}	Input Leakage Current		-10		10	μA
V_{IH}	High Swing High-level Input Voltage	$V_{REF} = V_{CC}$	2.0			V

Notes

1. Guaranteed by design. Voltage undershoot or overshoot cannot exceed absolute maximum conditions
2. VDDQ defines the maximum voltage level of Low Swing input. It is not an actual input voltage. Chip characterization for Low Swing operation is performed at 1.5V only. Voltage level of Low Swing input should never exceed absolute maximum rating.

DC Specifications

Under normal operating conditions unless otherwise specified.

Symbol	Parameter	Conditions	Min	Typ	Max	Units
V _{OD}	Differential Voltage Single ended peak to peak amplitude	R _{LOAD} = 50Ω, R _{EXT_SWING} = 510Ω	510	550	590	mV
V _{DOH}	Differential High-level Output Voltage ¹			AVCC		V
I _{DOS}	Differential Output Short Circuit Current ¹	V _{OUT} = 0 V			5	μA
I _{PD#}	Power-down Current ²			0.2	1.0	mA
I _{CT}	Transmitter Supply Current	IDCK= 165 MHz, 1-pixel/clock mode, R _{EXT_SWING} = 510Ω, IVCC = VCC, Worst Case Pattern ³		85	120	mA

Notes

1. Guaranteed by design.
2. Assumes all inputs to the transmitter are not toggling.
3. Black and white checkerboard pattern, each checker is one pixel wide.

AC Specifications

Under normal operating conditions unless otherwise specified.

Symbol	Parameter	Conditions	Min	Typ	Max	Units	Figure
T _{CIP}	IDCK Period, 1-pixel/clock		6		40	ns	Figure 3
F _{CIP}	IDCK Frequency, 1-pixel/clock		25		165	MHz	
T _{CIH}	IDCK High Time at 165MHz		2.0			ns	Figure 3
T _{CIL}	IDCK Low Time at 165MHz		2.0			ns	Figure 3
T _{IJIT}	Worst Case IDCK Clock Jitter ^{2,3}				2	ns	
T _{SIDF}	Data, DE, VSYNC, HSYNC Setup Time to IDCK falling edge (Default De-skew Setting)	Single Edge (DSEL = 0, EDGE = 0)	1.0			ns	Figure 6
T _{HIDF}	Data, DE, VSYNC, HSYNC Hold Time from IDCK falling edge (Default De-skew Setting)	Single Edge (DSEL = 0, EDGE = 0)	0.9			ns	Figure 6
T _{SIDR}	Data, DE, VSYNC, HSYNC Setup Time to IDCK rising edge ¹ (Default De-skew Setting)	Single Edge (DSEL = 0, EDGE = 1)	1.0			ns	Figure 6
T _{HIDR}	Data, DE, VSYNC, HSYNC Hold Time from IDCK rising edge ¹ (Default De-skew Setting)	Single Edge (DSEL = 0, EDGE = 1)	0.9			ns	Figure 6
T _{SID}	Data, DE, VSYNC, HSYNC Setup Time to IDCK falling/rising edge ¹ (Default De-skew Setting)	Dual Edge (DSEL = 1, BSEL = 0)	0.6			ns	
T _{HID}	Data, DE, VSYNC, HSYNC Hold Time from IDCK falling/rising edge ¹ (Default De-skew Setting)	Dual Edge (DSEL = 1, BSEL = 0)	1.3			ns	
T _{DDF}	VSYNC, HSYNC Delay from DE falling edge ¹		1T _{CIP}			ns	Figure 7
T _{DDR}	VSYNC, HSYNC Delay to DE rising edge ¹		1T _{CIP}			ns	Figure 7
T _{HDE}	DE high time ¹				8191T _{CIP}	ns	Figure 8
T _{LDE}	DE low time ¹		128T _{CIP}			ns	Figure 8
T _{STEP}	De-skew step size increment	DKEN = 1		260		ps	
T _{RESET}	Duration of RESET signal Low required for valid Reset		10			μs	Figure 5
T _{I2CDVD}	SDA Data Valid Delay from SCL high to low transition ³	C _L = 10pf			700	ns	Figure 9
		C _L = 400pf			2000	ns	
S _{HLT}	Differential Swing High-to-Low Transition Time	R _{LOAD} = 50Ω, R _{EXT_SWING} = 510Ω	170	200	230	ps	Figure 4
S _{LHT}	Differential Swing Low-to-High Transition Time	R _{LOAD} = 50Ω, R _{EXT_SWING} = 510Ω	170	200	230	ps	Figure 4

Notes

1. Guaranteed by design.
2. Actual jitter tolerance may be higher depending on the frequency of the jitter.
3. All Standard mode I²C (100kHz) timing requirements are guaranteed by design. Fast mode I²C (400kHz) timing requirements are guaranteed at 10pf loading.

Input Timing Diagrams

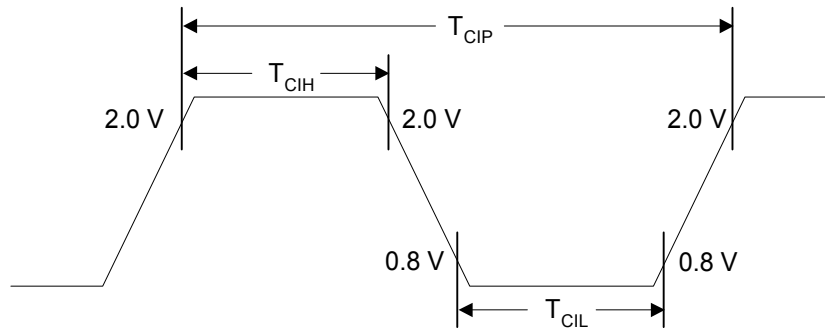

Figure 3. Clock Cycle High/Low Times

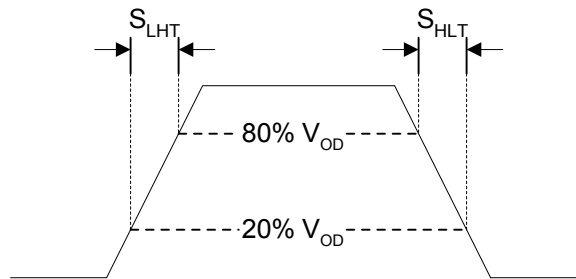

Figure 4. Low Swing Differential Times

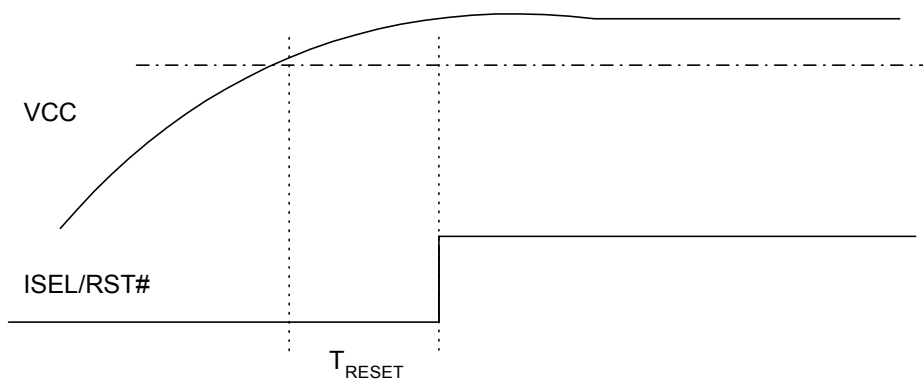

Figure 5. ISEL/RST# Minimum Timing

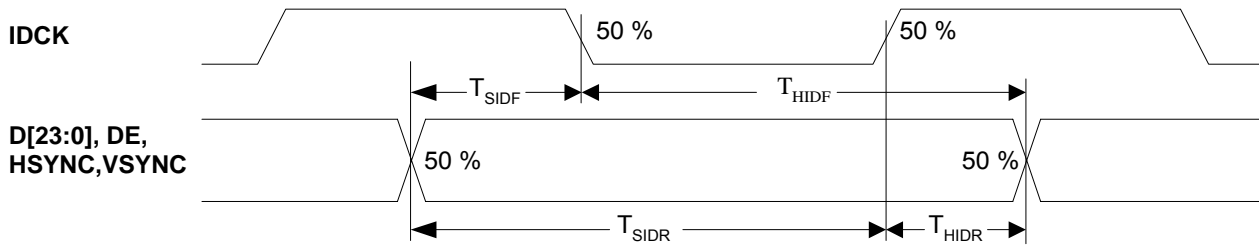

Figure 6. Input Data Setup/Hold Time to IDCK

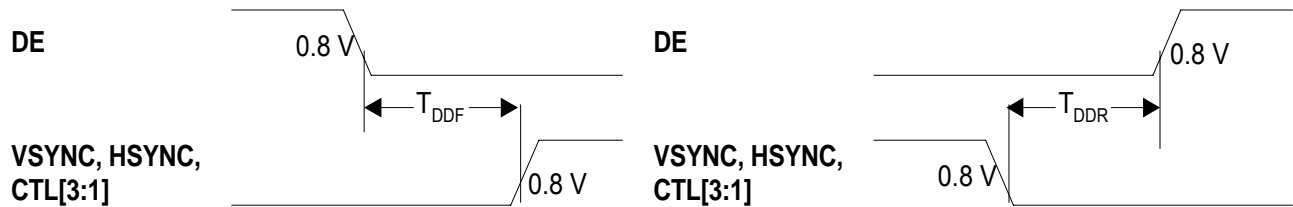

Figure 7. VSYNC, HSYNC and CTL[3:1] Delay Time from DE

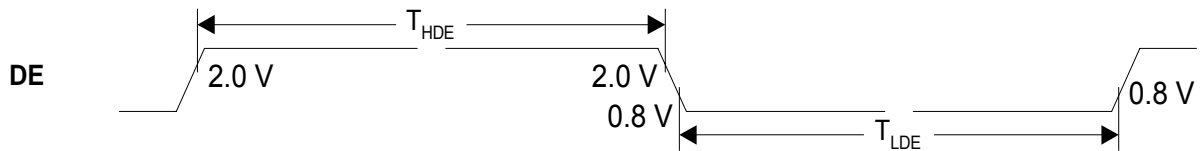

Figure 8. DE High and Low Times

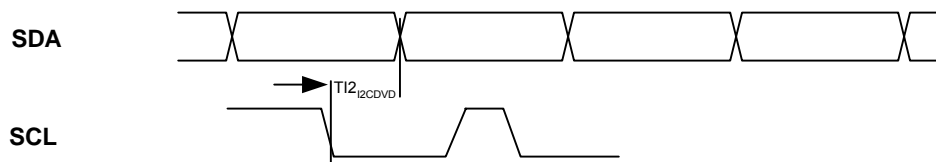

Figure 9. I²C Data Valid Delay (driving Read Cycle data)

Pin Descriptions

Input Pins

Pin Name	Pin #	Type	Description
D[23:12]	36-47	In	Top half of 24-bit pixel bus. When BSEL = HIGH , this bus inputs the top half of the 24-bit pixel bus. When BSEL = LOW , these bits are not used to input pixel data. In this mode, the state of D[23:16] is input to the I ² C register CFG. This allows 8-bits of user configuration data to be read by the graphics controller through the I ² C interface (see I ² C register definition). When not used D[23:16] should be tied to ground. D[15:12] are reserved for SiI use only and should be tied to GND.
D[11:0]	50-55, 58-63	In	Bottom half of 24-bit pixel bus / 12-bit pixel bus input. When BSEL = HIGH , this bus inputs the bottom half of the 24-bit pixel bus. When BSEL = LOW , this bus inputs ½ a pixel (12-bits) at every latch edge (both falling and/or rising) of the clock.
IDCK+	57	In	Input Data Clock +. This clock is used for all input modes.
IDCK-	56	In	Input Data Clock -. This clock is only used in 12-bit mode when dual edge clocking is turned off (DSEL = LOW). It is used to provide the ODD latching edges for dual clock single edge. If BSEL = HIGH or DSEL = HIGH , this pin is unused and should be tied to GND.
DE	2	In	Input Data Enable. This signal qualifies the active data area. DE is always required by the transmitter and must be high during active display time and low during blanking time.
HSYNC	4	In	Horizontal Sync input control Signal
VSYNC	5	In	Vertical Sync input control signal.
CTL1/A1/DK1 CTL2/A2/DK2 CTL3/A3/DK3	8 7 6	In	The use of these multi-function inputs depends on the settings of ISEL/RST# and DKEN. These inputs are regular high-swing 3.3V CMOS level inputs. These pins contain weak pull-down resistors so that if left unconnected, they will be LOW. When ISEL/RST# = LOW, DKEN = LOW General Purpose Input CTL[3:1] pins are active, for backward compatibility. These pins must be used to send DC signals only during the blanking time. When ISEL/RST# = LOW, DKEN = HIGH DK[3:1] are active, these inputs are used to select the De-skewing setting for the input bus. When ISEL/RST# = HIGH, DKEN = HIGH A[3:1] are active, these bits are used to set the lower 3 bits of the I ² C device address.

Pin Descriptions (cont'd)

Configuration Pins

Pin Name	Pin #	Type	Description
MSEN	11	Out	<p>Monitor Sense. This pin is an open collector output. The behavior of this output depends on whether I²C interface active:</p> <p>I²C bus inactive (ISEL/RST# = LOW) HIGH level indicates a powered on receiver is detected at the differential outputs. A LOW level indicates a powered on receiver is not detected.</p> <p>I²C bus is enabled (ISEL/RST# = HIGH) The output is programmable through the I²C interface (see I²C Register Definitions). An external 5K pull-up resistor to VDDQ is required on this pin.</p>
ISEL/RST#	13	In	<p>I²C Interface Select.</p> <p>ISEL/RST#=HIGH, I²C interface is active.</p> <p>ISEL/RST#=LOW, I²C is inactive and the chip configuration is read from the configuration strapping pins. This pin also acts as an asynchronous reset to the I²C interface controller. The reset is active when this input is held LOW.</p> <p>Note: When the I²C interface is active, DKEN must be set HIGH.</p>
BSEL/SCL	15	In	<p>Input bus select / I²C clock. This pin is an open collector input. If I²C bus is enabled (ISEL/RST# = HIGH), then this pin is the I²C clock input. If the I²C is disabled (ISEL/RST# = LOW), then this pin selects the input bus width.</p> <p>Input Bus Select: HIGH selects 24-bit input mode LOW selects 12-bit input mode</p>
DSEL/SDA	14	In/Out	<p>Dual edge clock select / I²C Data. This pin is an open collector input/output. If I²C bus is enabled (ISEL/RST# = HIGH), then this pin is the I²C data line. If the I²C bus is disabled (ISEL/RST# = LOW), then this pin selects whether single clock dual edge is used.</p> <p>Dual Edge clock select: When HIGH, IDCK+ latches input data on both falling <u>and</u> rising clock edges. When LOW, IDCK+/IDCK- latches input data on only falling or rising clock edges.</p> <p>In 24-/12-bit mode: If HIGH (dual edge), IDCK+ is used to latch data on both falling and rising edges. If LOW (single edge), IDCK+ latches 1st half data and IDCK- latches 2nd half data.</p>
EDGE/ HTPLG	9	In	<p>Edge select / Hot Plug input. If the I²C bus is enabled (ISEL/RST# = HIGH), then this pin is used to monitor the "Hot Plug" detect signal (Please refer to the DVI™ or VESA® P&D™ and DFP standards). This Input is ONLY 3.3V tolerant and has no internal de-bouncer circuit. If I²C bus is disabled (ISEL/RST# = LOW), then this pin selects the clock edge that will latch the data. How the EDGE setting works depends on whether dual or single edge latching is selected:</p> <p>Dual Edge Mode (DSEL = HIGH) EDGE = LOW, the primary edge (first latch edge after DE is asserted) is the falling edge. EDGE = HIGH, the primary edge (first latch edge after DE is asserted) is the rising edge.</p> <p>Note: In 24-bit Single Clock Dual Edge mode, EDGE is ignored.</p> <p>Single Edge Mode (DSEL = LOW) EDGE = LOW, the falling edge of the clock is used to latch data. EDGE = HIGH, the rising edge of the clock is used to latch data.</p>
DKEN	35	In	<p>De-skewing enable.</p> <p>I²C mode (ISEL/RST# = HIGH) DKEN pin must be set to HIGH. DK[3:1] pins are ignored and the De-skewing increments are selected through the I²C interface (see the I²C register definitions).</p> <p>Non I²C mode (ISEL/RST# = LOW) DKEN = LOW, then default De-skewing setting is used. DKEN = HIGH, then DK[3:1] is used as the De-skewing setting. The De-skewing increments are T_{STEP}. Please see Data De-skew Feature for an illustration.</p>

Pin Descriptions (cont'd)

Input Voltage Reference Pin

Pin Name	Pin #	Type	Description
VREF	3	Analog In	<p>Input Reference Voltage. Selects the Swing range of the digital inputs, which include only D[23:0], IDCK+, IDCK-, DE, VSYNC, and HSYNC. Input pins SCL and SDA, RST, BSEL, DSEL, EDGE and PD# require 3.3V high swing signals and are not changed by the VREF input.</p> <p>To set the digital inputs to 3.3V High Voltage Swing, VREF must be set to 3.3V.</p> <p>To set the digital inputs to Low Voltage Swing, VREF must be set to ½ of VDDQ where VDDQ is swing level of input signal. Thus for DVO mode(1.5V Low Voltage Swing) VREF should be set to 0.75V and BSEL=LOW.</p>

Power Management Pins

Pin Name	Pin #	Type	Description
PD#	10	In	<p>Power Down (active LOW). A HIGH level indicates normal operation. A LOW level indicates Power Down mode. In Power Down mode the Analog core is disabled and Output buffers/pins are tri-stated however the Input buffer/pins and I²C Block for read and write are active. PD# pin is disabled during I²C mode. PD# should be tied low during I²C mode.</p>

Differential Signal Data Pins

Pin Name	Pin #	Type	Description
TX0+	25	Analog	<p>TMDS Low Voltage Differential Signal input data pairs.</p> <p>These pins are tri-stated when PD# is pulled low.</p>
TX0-	24	Analog	
TX1+	28	Analog	
TX1-	27	Analog	
TX2+	31	Analog	
TX2-	30	Analog	
TXC+	22	Analog	<p>TMDS Low Voltage Differential Signal input clock pair.</p> <p>These pins are tri-stated when PD# is pulled low.</p>
TXC-	21	Analog	
EXT_SWING	19	Analog	<p>Voltage Swing Adjust. A resistor should tie this pin to AVCC. This resistor sets the amplitude of the voltage swing. A smaller resistor value sets a larger voltage swing and vice versa. For remote display applications a 510Ω resistor is recommended. While for notebook computers 680Ω is recommended to ensure voltage swing is not overdriven over a short cable distance.</p>

Reserved Pins

Pin Name	Pin #	Type	Description
RESERVED	34	In	Must be tied LOW for normal operation.

Power and Ground Pins

Pin Name	Pin #	Type	Description
VCC	1,12,33	Power	Digital VCC, must be set to 3.3V nominal.
GND	16,48,64	Ground	Digital GND.
AVCC	23,29	Power	Analog VCC, must be set to 3.3V nominal.
AGND	20,26,32	Ground	Analog GND.
PVCC1	18	Power	Primary PLL Analog VCC, must be set to 3.3V nominal.
PVCC2	49	Power	Filter PLL Analog VCC, must be set to 3.3V nominal.
PGND	17	Ground	PLL Analog GND.

I²C Registers

I²C Register Mapping

Addr.	Bit 7	Bit 6	Bit 5	Bit 4	Bit 3	Bit 2	Bit 1	Bit 0
0x00	VND_IDL (RO)							
0x01	VND_IDH (RO)							
0x02	DEV_IDL (RO)							
0x03	DEV_IDH (RO)							
0x04	DEV_REV (RO)							
0x05	RSVD[7:0]							
0x06	FRQ_LOW (RO)							
0x07	FRQ_HIGH (RO)							
0x08	RSVD[1:0]		VEN (R/W)	HEN (R/W)	DSEL (RW)	BSEL (RW)	EDGE (RW)	PD (RW)
0x09	VLOW (RO)	MSEL[2:0] (RW)			TSEL (RW)	RSEN (RO)	HTPLG (RO)	MDI (RW)
0x0A	DK[3:1] (RW)			DKEN (RW)	CTL[3:1] (RW)			RSVD
0x0B	CFG[7:0] ⁴ (RO)							
0x0C ⁷	SCNT (RW)	RSVD			PLL[3:1] (RW)			PFEN (RW)
0x0D	RSVD[3:0]				RSVD[3:0]			
0x0E	RSVD[7:0]							
0x0F	RSVD[7:0]							

Notes

1. All values are Bit 7(MSB) and Bit 0(LSB).
2. Registers that can be written and read from are listed as (R/W) while registers that can be read only are listed with (RO).
3. Actual jitter tolerance may be higher depending on the frequency of the jitter.
4. Contents of this register are dependent on the status of pins D[23:16].
5. After the RESET signal is deasserted in I²C mode, only PD and MSEL have a default value or can retain their programmed value set before the reset. All other registers do not have a default value or retain their value after a reset. As such all required registers other than PD and MSEL must be reinitialized in I²C mode after being powered up or reset.
6. Registers listed as RSVD are reserved and for Silicon Image, Inc use only.
7. 0x0C is also called the **VDJK** Register. Default setting for the VDJK register 0x0C is 89h, which is optimum for most applications.

I²C Register Definitions

Register Name	Access	Description
VND_IDL	RO	Vendor ID Low byte (01h)
VND_IDH	RO	Vendor ID High byte (00h)
DEV_IDL	RO	Device ID Low byte (06h)
DEV_IDH	RO	Device ID High byte (00h)
DEV_REV	RO	Device Revision (00h)
FRQ_LOW	RO	Low frequency limit at 1-pixel/clock mode (MHz) (19h)
FRQ_HIGH	RO	High frequency limit at 1-pixel/clock mode Max frequency minus 65MHz (MHz) (64h)
PD	RW	Power Down mode (same function as PD# pin) 0 – Power Down (Default after RESET) 1 – Normal operation
EDGE	RW	Edge Select (same function as EDGE pin) 0 – Input data is falling edge latched (falling edge latched first in dual edge mode) 1 – Input data is rising edge latched (rising edge latched first in dual edge mode)
BSEL	RW	Input Bus Select (same function as BSEL pin) 0 – Input data bus is 12-bits wide 1 – Input data bus is 24-bits wide
DSEL	RW	Dual Edge Clock Select (same function as DSEL pin) 0 – Input data is single edge latched 1 – Input data is dual edge latched
HEN	RW	Horizontal Sync Enable: 0 – HSYNC input is transmitted as fixed LOW 1 – HSYNC input is transmitted as is
VEN	RW	Vertical Sync Enable: 0 – VSYNC input is transmitted as fixed LOW 1 – VSYNC input is transmitted as is
MDI	RW	Monitor Detect Interrupt 0 – Detection signal has changed logic level (write one to this bit to clear) 1 – Detection signal has not changed state
HTPLG	RO	Hot Plug Detect input, the state of HTPLG pin can be read from this bit
RSEN	RO	Receiver Sense (only available for use in DC coupled systems) 0 – Active/Powered Receiver not detected 1 – Active/Powered Receiver detected
TSEL	RW	Interrupt Generation Method 0 – Interrupt bit (MDI) is generated by monitoring RSEN 1 – Interrupt bit (MDI) is generated by monitoring HTPLG
MSEL[2:0]	RW	Select source of the MSEN output pin 000 – Force MSEN outputs high (disabled – default after RESET) 001 – Outputs the MDI bit (interrupt) 010 – Output the RSEN bit (receiver detect) 011 – Outputs the HTPLG bit (hot plug detect) 1xx – RESERVED
VLOW	RO	This bit is a 1 if the VREF setting 1 – Indicates High Swing inputs 0 – Indicates Low Swing inputs
CTL[3:1]	RW	General purpose inputs (same as CTL[3:1] pins)

I²C Register Definitions (cont'd)

Register Name	Access	Description
CFG[7:0]	RO	Contains state of inputs D[23:16]. These pins can be used to provide user selectable configuration data through the I ² C bus. Only available in 12-bit mode
PFEN	RW	PLL Filter Enable in the VDJK Register. 1 – To enable PLL Filter (recommended setting) 0 – To disable PLL Filter
PLLF[3:1]	RW	Set characteristics of PLL filter in the VDJK register 100 – Recommended value
SCNT	RW	SYNC Continuous 1 – To enable (recommended setting) 0 – To disable
DK[3:1]	RW	De-skewing Setting. Increment 260psec. 000 – 1 step -> minimum setup / maximum hold 001 – 2 step 010 – 3 step 011 – 4 step 100 – 5 step -> default (recommended setting) 101 – 6 step 110 – 7 step 111 – 8 step -> maximum setup / minimum hold Please see Data De-Skew Feature for an illustration
DKEN	RW	De-skewing Enable through DK[3:1] bits. When DKEN pin is HIGH via pin or set to 1, then De-skew is enabled. When set to 0 De-skew is disabled. Please see Data De-skew Feature for an illustration.

I²C Slave Interface and Address

The Sil 164 slave state machine does not require an internal clock and support only byte read and write. Page mode is not supported. The 7-bit binary address of the I²C machine is “0111 A₃A₂A₁R” where R =1 sets a read operation while R=0 sets a write operation. Please see Figure 10 for a Byte Read operation and Figure 11 for a byte write operation. For more detailed information on I²C protocols please refer to I²C Bus Specification version 2.1 available from Philips Semiconductors Inc.

When ISEL/RST# = HIGH and DKEN = HIGH, pins 6,7,8 functions as A[3:1]. Each pin can be set to HIGH or LOW to select a desired I²C address for the Sil 164. To set the Sil 164 to 72h, tie pin 7 and 6 to ground and pull pin 8 to VCC via 2.2K resistor. The recommended setting is to tie pins 6,7 and 8 to ground to set “000” or address 70h in I²C mode .

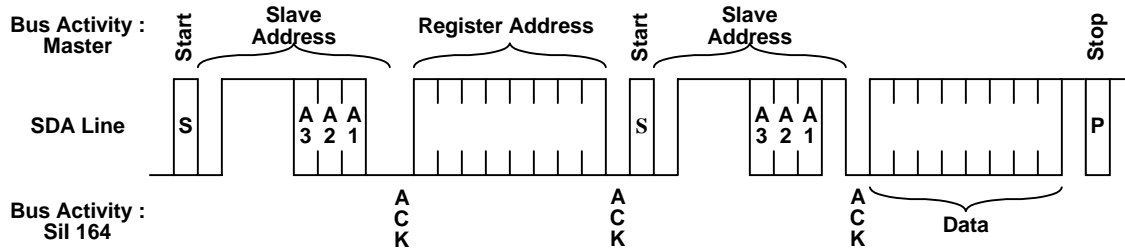

Figure 10. I²C Byte Read

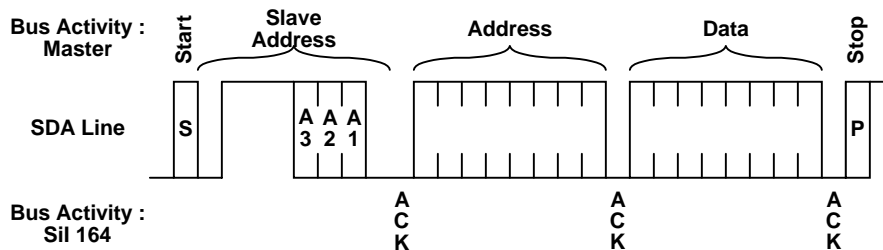

Figure 11. I²C Byte Write

Data De-skew Feature

The de-skew feature allows adjustment of the clock-to-data delay on the input of the SiI 164. When driven by a chip with clock and data timings which do not meet the setup and hold time requirements of an SiI 164, the de-skew register value can be modified to position the clock in the middle of the valid data time and meet the input setup and hold times. As shown in Figure 12, changing the DK[3:1] value from 0b100 to 0b111 delays the internal clock by approximately 750ps to 900ps, increasing setup time and reducing hold time. This is useful when the input clock, IDCK, arrives too early.

The default values for DK[3:1] are shown in Table 1, along with approximate times per setting. Note that the default is different when enabling I²C mode (ISEL/RST#=HIGH) versus non-I²C mode (ISEL/RST#=LOW). Positive values of T_{CD} move the clock later, increasing setup time. Negative values of T_{CD} move the clock earlier, increasing hold time.

Where:

T_{CD} is the amount of setup/hold timing variation

DK[3:1] is the setting of the de-skew configuration pins or I²C registers

Table 1. Data De-Skew Estimated Values

DK[3:1]	De-Skew Time T_{CD}
111	+0.75ns to +0.90ns
110	+0.50ns to +0.70ns
101	+0.20ns to +0.35ns
100	0
011	-0.20ns to -0.35ns
010	-0.50ns to -0.70ns
001	-0.75ns to -0.90ns
000	-1.0ns to -1.2ns

Default De-Skew

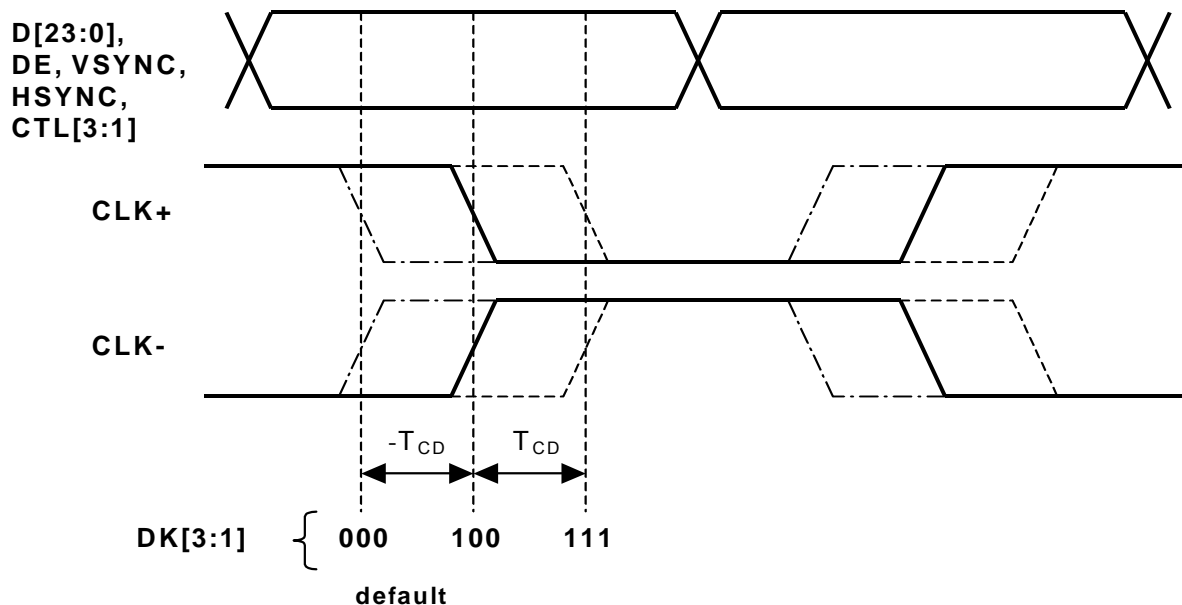

Figure 12. SiI 164 Data De-skew Feature Timing

Data Latching Modes

SiI 164 can be set to different to operate in either 12 bit or 24 bit input mode. In either mode the SiI 164 can be set to latch data at either rising or falling edge of the clock or support dual edge clocking mode. Figure 13 illustrates the latching edge for a 12 bit data input (**BSEL = 0**) by changing DSEL and EDGE option. Clock edges represented by arrows signify the latching edge. For Dual Edge mode, the dark arrows indicate the primary latch edge.

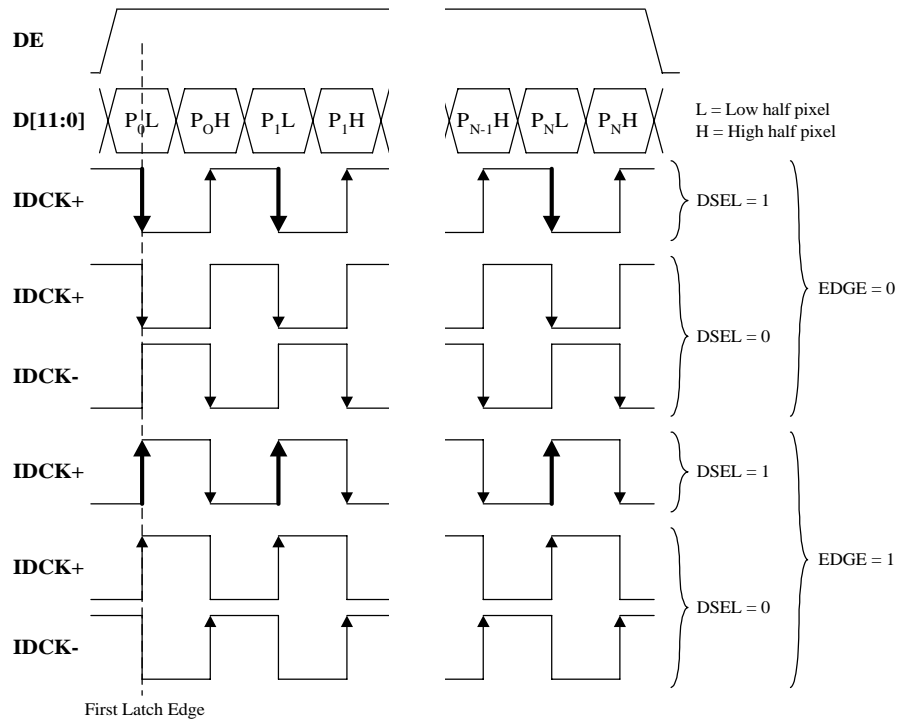

Figure 13. 12 bit Input Data Latching

Figure 14 illustrates the latching edge for a 24 bit data input (**BSEL=1**) with DSEL and EDGE option. EDGE pin has no affect in 24-bit Single Clock Dual Edge Mode.

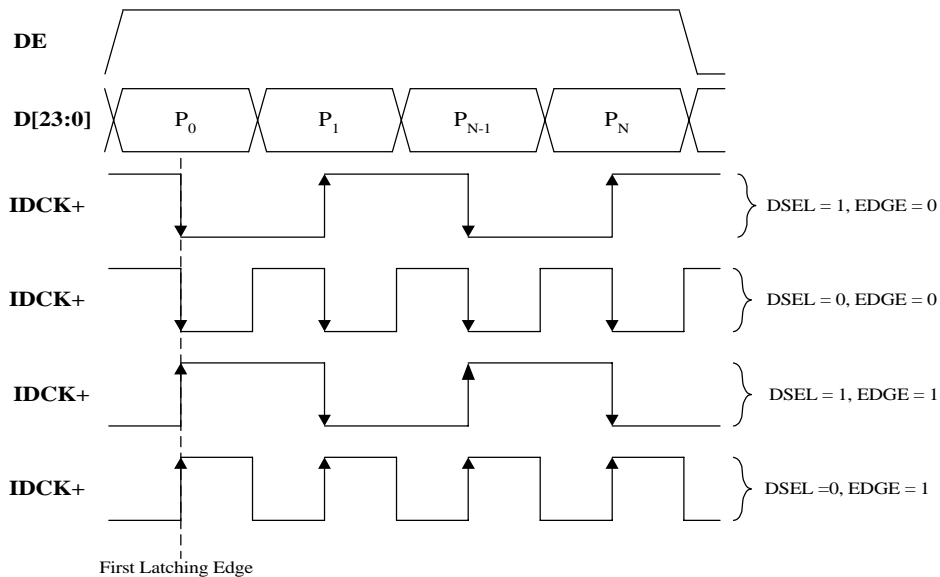

Figure 14. 24 bit Input Data Latching

I²C Programming Sequence

To program the SiI 164 in data latched on 12 bit mode Dual Edge Clock with Primary Edge as the rising edge, De-skew enabled without Hotplug and the following sample programming sequence listed in Table 2 may be used. It is important to note that the suggested I²C address for SiI 164 be set to x70h by tying A1, A2 and A3 to ground.

Table 2. Sample Programming Sequence for SiI 164

Register(Hex)	Value(Hex)	Description
0x08	30	Enable HEN, VEN, 1 st data latched on falling edge with PD low until all registers are programmed.
0x09	00	MSEN disabled.
0x0A	90	De-skew enabled with default 100 value. CTL is not used.
0x0C	89	SCNT, PLL Filter Enable and PLL Bandwidth Filter set to default.
0x08	31	Set PD to High after the registers above have been programmed.

Enabling Hot Plug Detection Mode

As documented in the VESA Digital Flat Panel Standard, all monitors are required to support Hot Plug Detection but support is optional for the host. The SiI 164 supports the Hot Plug Detect feature. In I²C mode, pin 9 functions as HTPLG input. It should be noted that the HTPLG pin on the SiI 164 is only 3.3V tolerant therefore HTPLG voltage level from the DVI connector should be level shifted or clamped at 3.3V.

When the voltage level at the HTPLG pin is 3.3V, the HTPLG bit will be set to 1. To output the HTPLG bit via the MSEN pin, register MSEL[2:0] should be programmed to 011.

The SiI 164 can also be programmed to enable the Hot Plug Detection Mode via the Receiver Sense function. In this mode, HTPLG pin is not required. By programming MSEL[2:0] to 010, SiI 164 will output the RSEN=1 bit though the MSEN pin when the SiI 164 is connected to a powered receiver.

Non I²C Mode Configuration

The Sil 164 can be set to program itself at power up without writing any Sil 164 registers via I²C. The Sil 164 is extremely flexible and can be set to operate in any input format that can be set in I²C mode. In non I²C mode, specific configuration pins need to be strapped to either high or low to set the desired mode. Figure 15 provides a schematic example of all the pins that can be configured to enable the various modes in non I²C mode. Table 3 lists resistors to be stuffed for a specific mode.

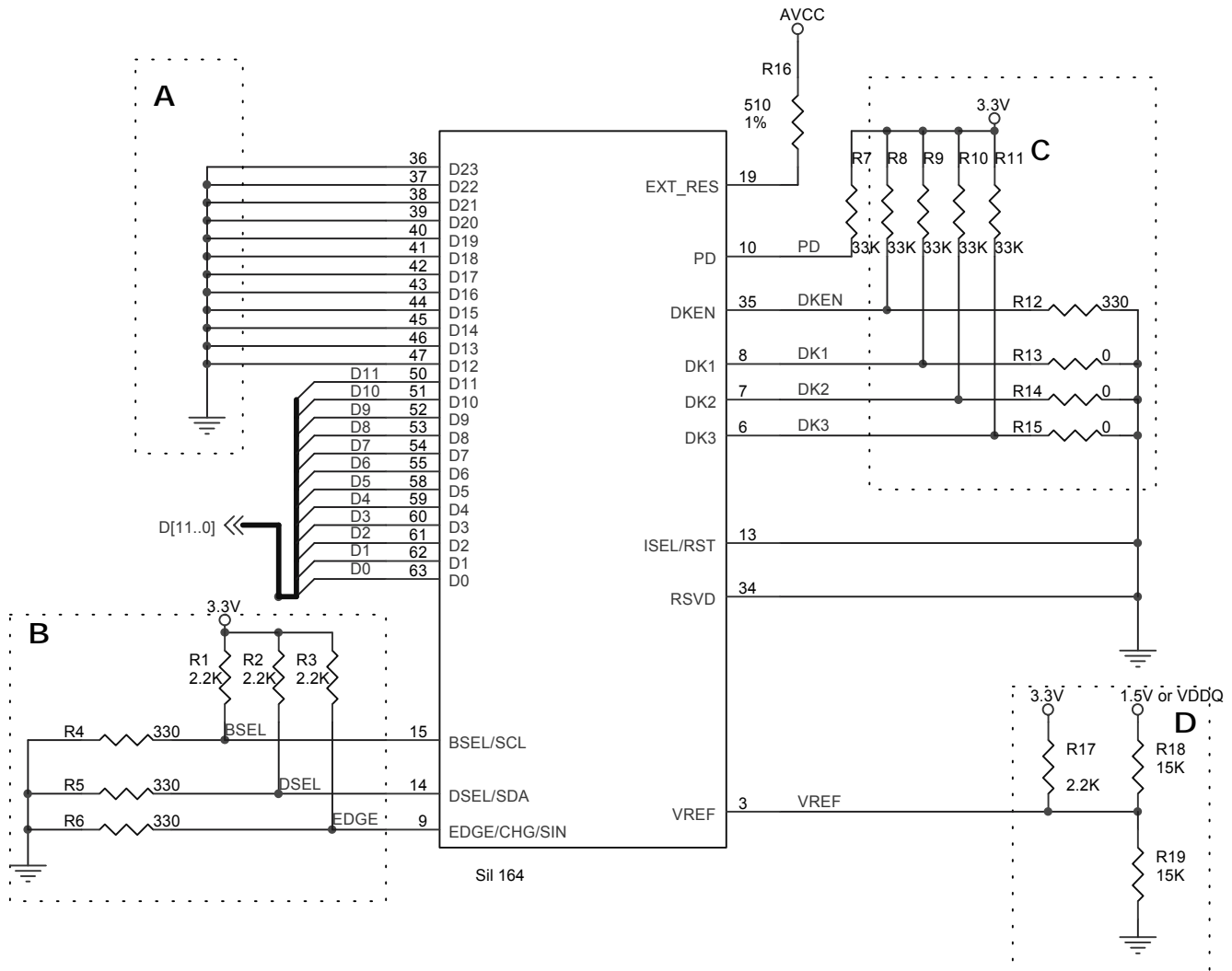

Figure 15. Non I²C Mode Schematic Example

Non I²C Mode Configuration (cont'd)

ISEL/RST# and RSVD pins must always be tied to ground for non I²C mode. PD# must be tied high or the SiI 164 will still be in Power Down mode when VCC is applied.

In Figure 15 **Block A** corresponds to the upper 12 bits (D [23:12]) of the SiI 164. When not in use, they should always be tied to ground. **Block B** controls the Input Bus data width, Dual Edge Clock Select and Edge Select. IDCK- is only used in 12 bit mode. In 24 bit mode or Dual Edge Clock select IDCK- should be tied to ground. **Block C** controls the De-skew options. **Block D** determines the input voltage level swing. A full description of each pin can be found in the Pin Description section of this document.

Table 3. Non I²C Strapping Mode Options

MODE	BLOCK A	BLOCK B	BLOCK C	BLOCK D
1. 24 bit ¹ 2. Single Clock 3. Dual Edge 4. Falling Edge latching 1 st pixel 5. De-skewing enabled to 100 6. High Voltage Swing	Connect D[23:12] to VGA Source	Stuff only R1, R2, R6	Stuff only R8, R13, R14, R11	Stuff Only R17
1. 24 bit 2. Single Clock 3. Single Edge 4. Falling Edge 5. De-skewing disabled 6. High Voltage Swing.	Connect D[23:12] to VGA Source	Stuff only R1, R5, R6	Stuff only R12, R13, R14, R15	Stuff Only R17
1. 12 bit ² 2. Single Clock 3. Dual Edge 4. Rising Edge of IDCK+ latching 1 st ½ pixel 5. De-skewing disabled 6. High Voltage Swing.	Ground D[23:12]	Stuff only R4, R2, R3	Stuff only R12, R13, R14, R15	Stuff Only R17
1. 12 bit ³ 2. Dual Clock 3. Dual Edge, 4. Falling Edge of IDCK+ latching 1 st ½ pixel 5. De-skewing enabled to 100 6. Low Swing Mode	Ground D[23:12]	Stuff only R4, R5, R6	Stuff only R8, R13, R14, R11	Stuff Only R18, R19

Notes

- In 24 bit IDCK+ is input clock. IDCK- should be tied to ground.
- In 12 bit dual edge mode, IDCK- is not used.
- This setting is equivalent to DVO mode. In DVO mode both IDCK+ and IDCK- must be connected.

TFT Panel Data Mapping

The following TFT data mapping tables are strictly listed for single link TFT applications only. Sil 143B, Sil 151B, Sil 153B and Sil 161B all have the same pinout. As such mapping will be the same when Sil 143B or Sil 151B or Sil 153B is used in place of Sil 161B.

Table 4. One Pixel/Clock Input/Output TFT Mode - VESA P&D and FPD1-2 Compliant

TFT VGA Output		Tx Input Data		Rx Output Data		TFT Panel Input	
24-bpp	18-bpp	160	164	161B	141B	24-bpp	18-bpp
B0		DIE0	D0	QE0	Q0	B0	
B1		DIE1	D1	QE1	Q1	B1	
B2	B0	DIE2	D2	QE2	Q2	B2	B0
B3	B1	DIE3	D3	QE3	Q3	B3	B1
B4	B2	DIE4	D4	QE4	Q4	B4	B2
B5	B3	DIE5	D5	QE5	Q5	B5	B3
B6	B4	DIE6	D6	QE6	Q6	B6	B4
B7	B5	DIE7	D7	QE7	Q7	B7	B5
G0		DIE8	D8	QE8	Q8	G0	
G1		DIE9	D9	QE9	Q9	G1	
G2	G0	DIE10	D10	QE10	Q10	G2	G0
G3	G1	DIE11	D11	QE11	Q11	G3	G1
G4	G2	DIE12	D12	QE12	Q12	G4	G2
G5	G3	DIE13	D13	QE13	Q13	G5	G3
G6	G4	DIE14	D14	QE14	Q14	G6	G4
G7	G5	DIE15	D15	QE15	Q15	G7	G5
R0		DIE16	D16	QE16	Q16	R0	
R1		DIE17	D17	QE17	Q17	R1	
R2	R0	DIE18	D18	QE18	Q18	R2	R0
R3	R1	DIE19	D19	QE19	Q19	R3	R1
R4	R2	DIE20	D20	QE20	Q20	R4	R2
R5	R3	DIE21	D21	QE21	Q21	R5	R3
R6	R4	DIE22	D22	QE22	Q22	R6	R4
R7	R5	DIE23	D23	QE23	Q23	R7	R5
Shift CLK	Shift CLK	IDCK	IDCK	ODCK	ODCK	Shift CLK	Shift CLK
VSYNC	VSYNC	VSYNC	VSYNC	VSYNC	VSYNC	VSYNC	VSYNC
HSYNC	HSYNC	HSYNC	HSYNC	HSYNC	HSYNC	HSYNC	HSYNC
DE	DE	DE	DE	DE	DE	DE	DE

For 18-bit mode, the Flat Panel Graphics Controller interfaces to the transmitter exactly the same as in the 24-bit mode; however, 6 bits per channel (color) are used instead of 8. It is recommended that unused data bits be tied low. As can be seen from the above table, the data mapping for less than 24-bit per pixel interfaces are MSB justified. The data is sent during active display time while the control signals are sent during blank time. Note that the three data channels (CH0, CH1, CH2) are mapped to Blue, Green and Red data respectively.

Table 5. 24-bit One Pixel/Clock Input with 24-bit Two Pixels/Clock Output TFT Mode

TFT VGA Output 24-bpp	Tx Input Data		Rx Output Data	TFT Panel Input
	160	164	161B	24-bpp
B0	DIE0	D0	QE0	B0 - 0
B1	DIE1	D1	QE1	B1 - 0
B2	DIE2	D2	QE2	B2 - 0
B3	DIE3	D3	QE3	B3 - 0
B4	DIE4	D4	QE4	B4 - 0
B5	DIE5	D5	QE5	B5 - 0
B6	DIE6	D6	QE6	B6 - 0
B7	DIE7	D7	QE7	B7 - 0
G0	DIE8	D8	QE8	G0 - 0
G1	DIE9	D9	QE9	G1 - 0
G2	DIE10	D10	QE10	G2 - 0
G3	DIE11	D11	QE11	G3 - 0
G4	DIE12	D12	QE12	G4 - 0
G5	DIE13	D13	QE13	G5 - 0
G6	DIE14	D14	QE14	G6 - 0
G7	DIE15	D15	QE15	G7 - 0
R0	DIE16	D16	QE16	R0 - 0
R1	DIE17	D17	QE17	R1 - 0
R2	DIE18	D18	QE18	R2 - 0
R3	DIE19	D19	QE19	R3 - 0
R4	DIE20	D20	QE20	R4 - 0
R5	DIE21	D21	QE21	R5 - 0
R6	DIE22	D22	QE22	R6 - 0
R7	DIE23	D23	QE23	R7 - 0
			QO0	B0 - 1
			QO1	B1 - 1
			QO2	B2 - 1
			QO3	B3 - 1
			QO4	B4 - 1
			QO5	B5 - 1
			QO6	B6 - 1
			QO7	B7 - 1
			QO8	G0 - 1
			QO9	G1 - 1
			QO10	G2 - 1
			QO11	G3 - 1
			QO12	G4 - 1
			QO13	G5 - 1
			QO14	G6 - 1
			QO15	G7 - 1
			QO16	R0 - 1
			QO17	R1 - 1
			QO18	R2 - 1
			QO19	R3 - 1
			QO20	R4 - 1
			QO21	R5 - 1
			QO22	R6 - 1
			QO23	R7 - 1
Shift CLK	IDCK	IDCK	ODCK	Shift CLK/2
VSYNC	VSYNC	VSYNC	VSYNC	VSYNC
HSYNC	HSYNC	HSYNC	HSYNC	HSYNC
DE	DE	DE	DE	DE

Table 6. 18-bit One Pixel/Clock Input with 18-bit Two Pixels/Clock Output TFT Mode

TFT VGA Output	Tx Input Data		Tx Output Data		TFT Panel Input
18-bpp	160	164	161B	141B	18-bpp
	DIE0	D0	QE0		
	DIE1	D1	QE1		
B0	DIE2	D2	QE2	Q0	B0 - 0
B1	DIE3	D3	QE3	Q1	B1 - 0
B2	DIE4	D4	QE4	Q2	B2 - 0
B3	DIE5	D5	QE5	Q3	B3 - 0
B4	DIE6	D6	QE6	Q4	B4 - 0
B5	DIE7	D7	QE7	Q5	B5 - 0
	DIE8	D8	QE8		
	DIE9	D9	QE9		
G0	DIE10	D10	QE10	Q6	G0 - 0
G1	DIE11	D11	QE11	Q7	G1 - 0
G2	DIE12	D12	QE12	Q8	G2 - 0
G3	DIE13	D13	QE13	Q9	G3 - 0
G4	DIE14	D14	QE14	Q10	G4 - 0
G5	DIE15	D15	QE15	Q11	G5 - 0
	DIE16	D16	QE16		
	DIE17	D17	QE17		
R0	DIE18	D18	QE18	Q12	R0 - 0
R1	DIE19	D19	QE19	Q13	R1 - 0
R2	DIE20	D20	QE20	Q14	R2 - 0
R3	DIE21	D21	QE21	Q15	R3 - 0
R4	DIE22	D22	QE22	Q16	R4 - 0
R5	DIE23	D23	QE23	Q17	R5 - 0
			Q00		
			Q01		
			Q02	Q18	B0 - 1
			Q03	Q19	B1 - 1
			Q04	Q20	B2 - 1
			Q05	Q21	B3 - 1
			Q06	Q22	B4 - 1
			Q07	Q23	B5 - 1
			Q08		
			Q09		
			Q010	Q24	G0 - 1
			Q011	Q25	G1 - 1
			Q012	Q26	G2 - 1
			Q013	Q27	G3 - 1
			Q014	Q28	G4 - 1
			Q015	Q29	G5 - 1
			Q016		
			Q017		
			Q018	Q30	R0 - 1
			Q019	Q31	R1 - 1
			Q020	Q32	R2 - 1
			Q021	Q33	R3 - 1
			Q022	Q34	R4 - 1
			Q023	Q35	R5 - 1
Shift CLK	IDCK	IDCK	ODCK	Shift CLK/2	Shift CLK/2
VSYNC	VSYNC	VSYNC	VSYNC	VSYNC	VSYNC
HSYNC	HSYNC	HSYNC	HSYNC	HSYNC	HSYNC
DE	DE	DE	DE	DE	DE

Design Recommendations

1.5V to 3.3V I²C Bus Level-Shifting

To program the SiI 164 via I²C mode SDA and SCL swing level must be 3.3V. DVO sources have I²C swing of 1.5V. To ensure proper initialization of the SiI 164 a bi-directional voltage level-shifting circuit between the SiI 164 I²C bus and the VGA or driving source should be implemented. Two suggested components that can be used to achieve this is by using either a dual N-channel transistor like Fairchild Semiconductor's NDC7002N or the Philips GTL2010 High Speed Bus Switch. Refer to Figure 16 for a schematic example using a dual N-channel transistor for translating an I²C 1.5V signal to 3.3V I²C signal and vice versa.

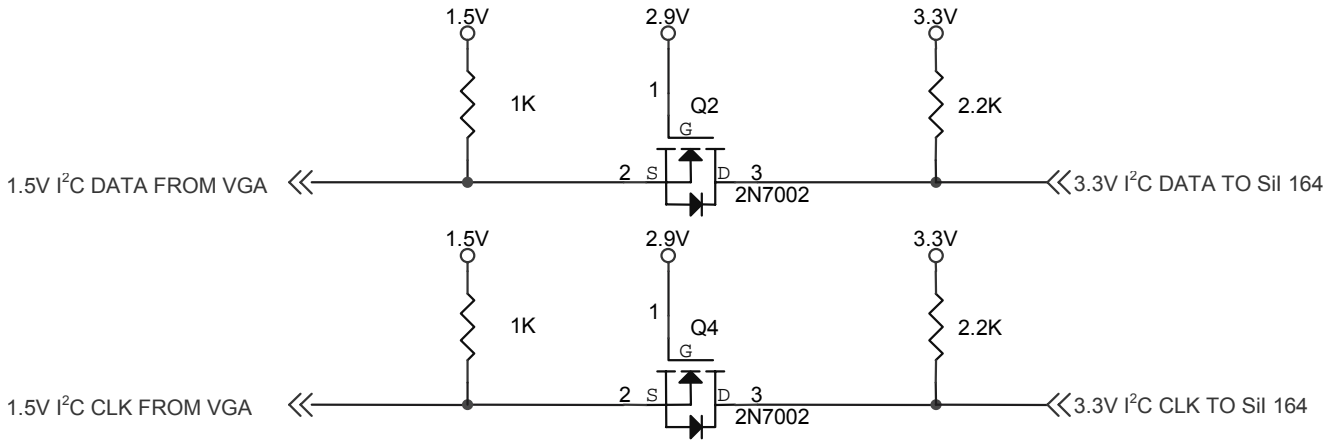

Figure 16. I²C Bus Voltage Level-Shifting using Fairchild NDC7002N

Figure 17 illustrates a schematic example using the Philips GTL 2010 to achieve a 1.5V to 3.3V bi-directional level-shift.

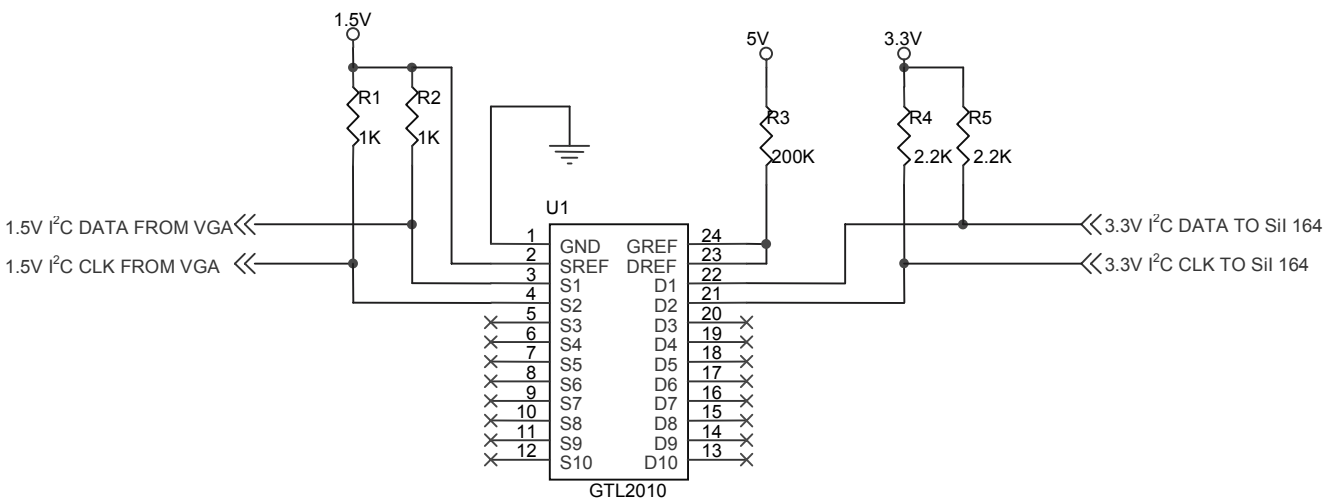

Figure 17. I²C Bus Voltage Level Shifting using Philips GTL 2010

Voltage Ripple Regulation

The power supply to PVCC is very important to the proper operation of the Transmitter chips. PVCC does not draw much current so any voltage regulator that can supply 50mA or more is sufficient. Two suggested voltage regulators are TL431 from Texas Instruments or LM317 from National Semiconductor. Two examples are shown in Figure 18 and Figure 19

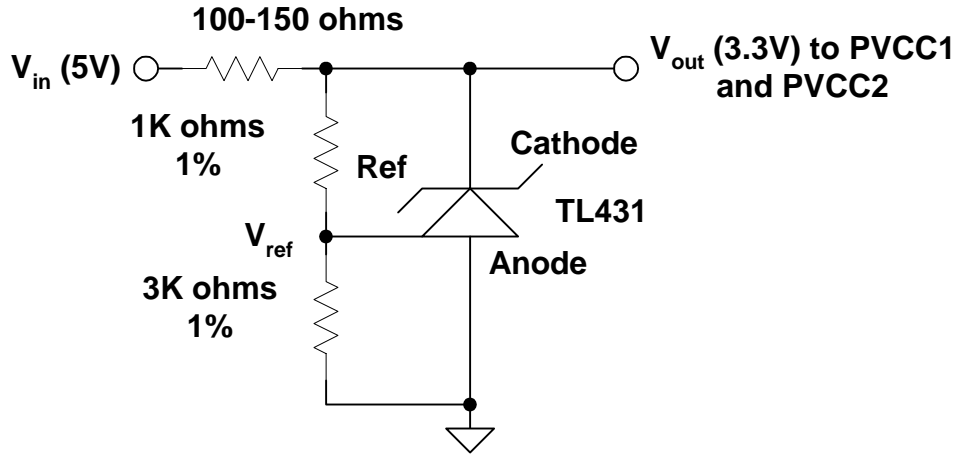

Figure 18. Voltage Regulation using TL431

Decoupling and bypass capacitors are also involved with power supply connections, as described in detail in Figure 20 and Figure 21.

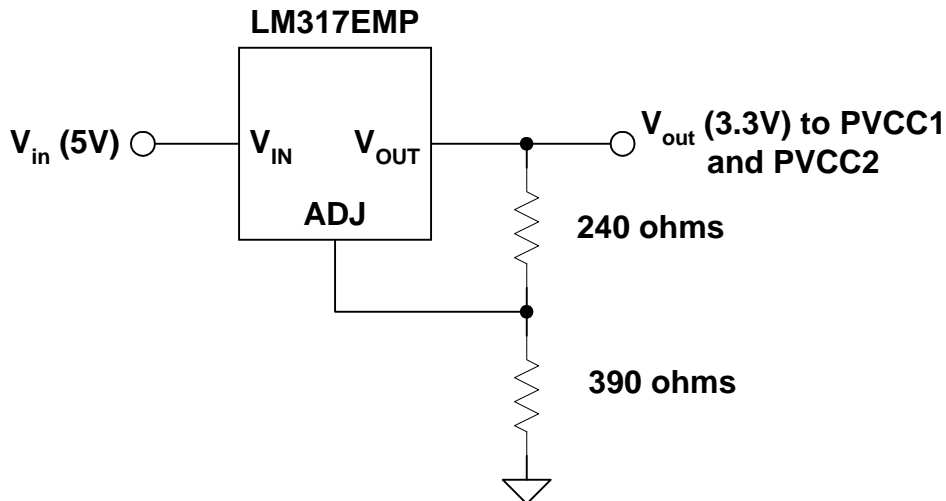

Figure 19. Voltage Regulation using LM317

Decoupling Capacitors

Designers should include decoupling and bypass capacitors at each power pin in the layout. These are shown schematically in Figure 21. Place these components as closely as possible to the SiI 164 pins, and avoid routing through vias if possible, as shown in Figure 20, which is representative of the various types of power pins on the transmitter.

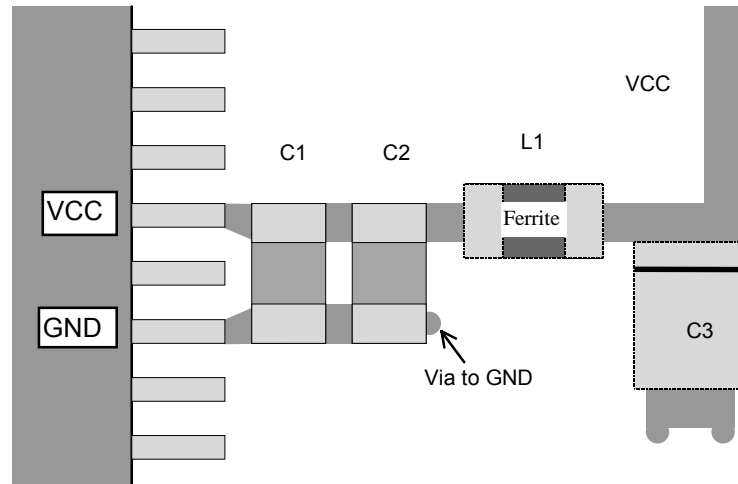

Figure 20. Decoupling and Bypass Capacitor Placement

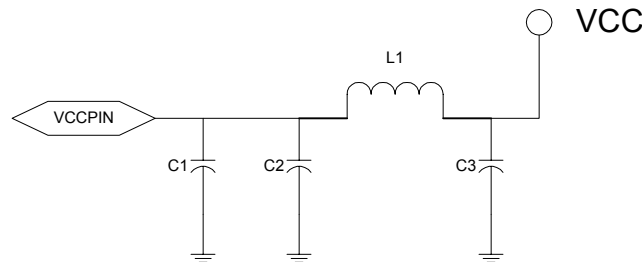

Figure 21. Decoupling and Bypass Schematic

The values shown in Table 7 are recommendations that should be adjusted according to the noise characteristics of the specific board-level design. Pins in one group (such as VCC) may share C2, L1, and C3, each pin having C1 placed as closely to the pin as possible.

Table 7. Recommended Components for Bypass and Decoupling Circuits

C1	C2	C3	L1
100 – 300 pF	2.2 – 10 μ F	10 μ F	200+ Ω

Series Damping Resistors on Outputs

Series resistors are effective in lowering the data-related emissions and reducing reflections. Series resistors with suggested value of 22Ω or 33Ω should be placed close to the output pins of the VGA Source or Graphics chip, as shown in Figure 22.

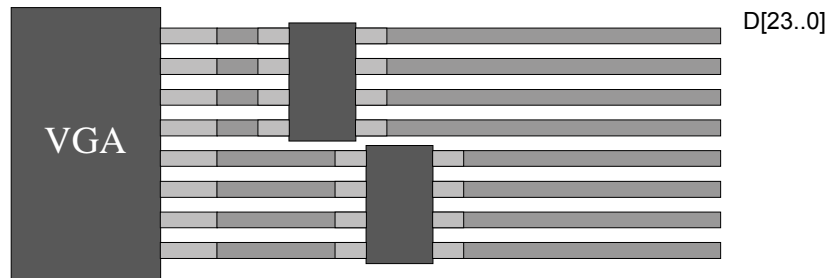

Figure 22. Series Input Damping Resistors for Driving Source

Differential Trace Routing

The routing for the SiI 164 chip is relatively simple since no spiral skew compensation is needed. However, a few small precautions are required to achieve the full performance and reliability of DVI.

The Transmitter can be placed fairly far from the output connector, but care should be taken to route each differential signal pair together and achieve impedance of 100Ω between the differential signal pair. However, note that the longer the differential traces are between the transmitter and the output connector, the higher the chance that external signal noise will couple onto the low-voltage signals and affect image quality.

Do not split or have asymmetric trace routing between the differential signal pair. Vias are very inductive and can cause phase delay problems if applied unevenly within a differential pair. Vias should be minimized or avoided if possible by placing all differential traces on the top layer of the PCB.

Figure 23 illustrates an incorrect routing of the differential signal from the SiI 164 to the DVI connector. Figure 24 illustrates the correct method to route the differential signal from the SiI 164 to the DVI connector. Figure 25 illustrates recommended routing for differential traces at the DVI connector.

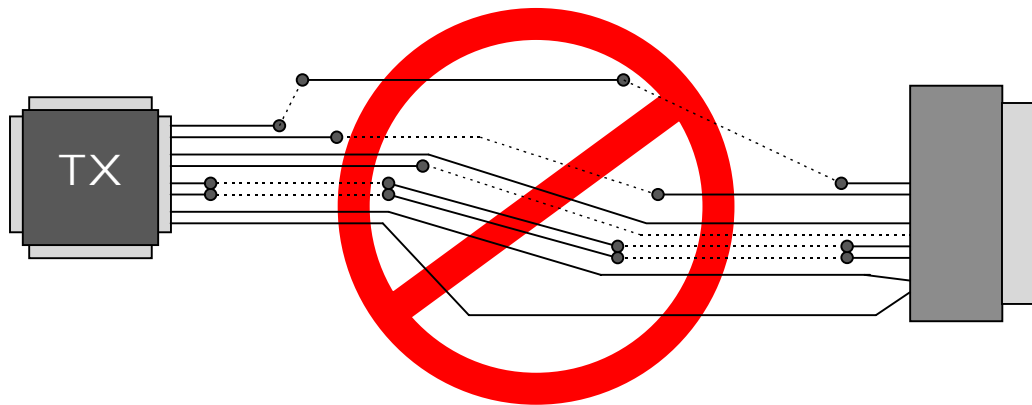

Figure 23. Example of Incorrect Differential Signal Routing

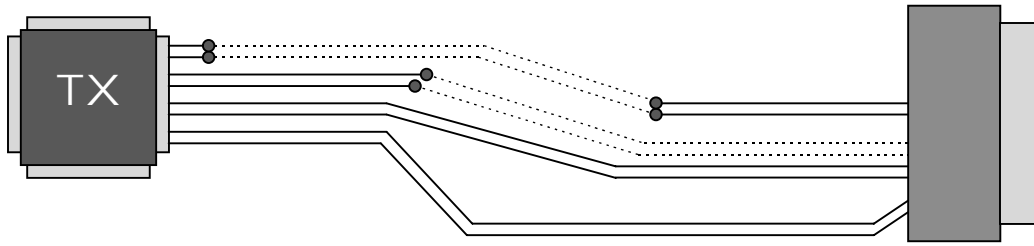

Figure 24. Example of Correct Differential Signal Routing

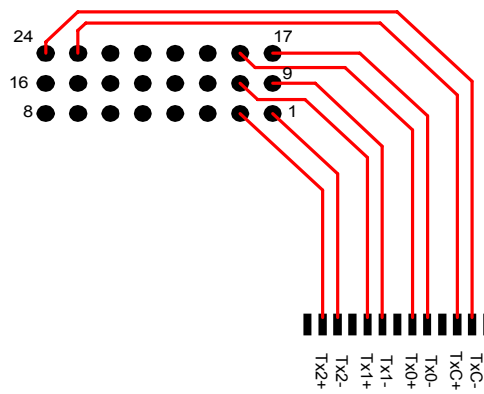
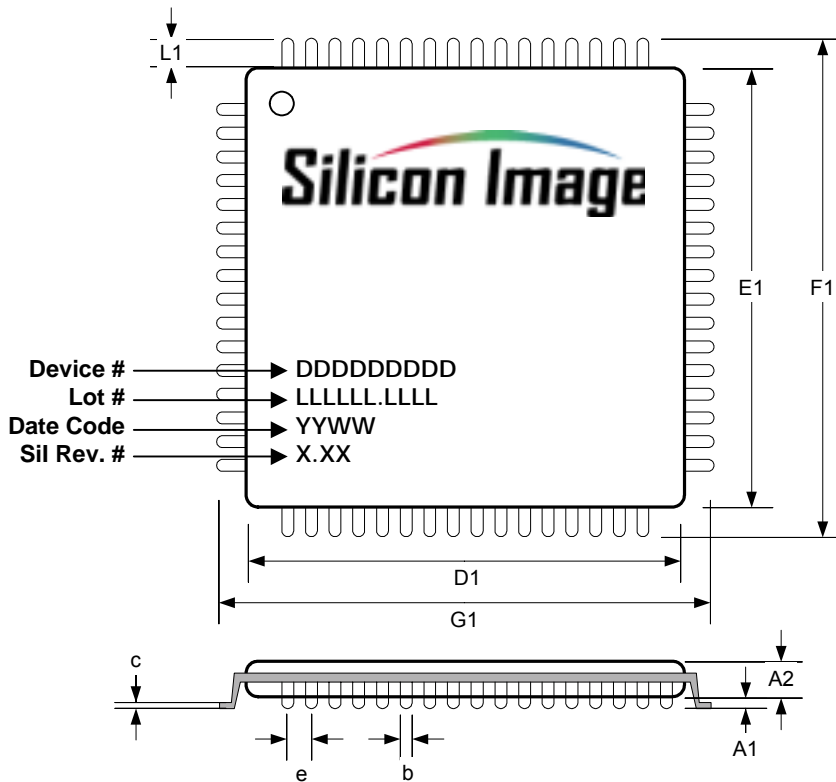

Figure 25. Differential Trace Routing to DVI Connector(Top Side View)

Package Dimensions and Marking Specification



JEDEC Package Code MS026-AED-HD

		typ	max
A	Thickness		1.20
A1	Stand-off		0.15
A2	Body Thickness	1.00	1.05
D1	Body Size	8.00	
E1	Body Size	10.00	
F1	Footprint	12.00	
G1	Footprint	12.00	
L1	Lead Length	1.00	
b	Lead Width	0.22	
c	Lead Thickness	0.20	
e	Lead Pitch	0.50	

Dimensions in millimeters.
Overall thickness $A = A1 + A2$.

Device Device Number DDDDDDDD

Standard	Sil164CT64
Pb-Free	Sil164CTG64

Legend Description

LLLLLL.LLLL	Lot Number
YY	Year of Mfr
WW	Work Week of Mfr.
X.XX	Revision

Figure 26. 64-pin TQFP Package Dimensions (JEDEC code MS-026ED)

Ordering Information

Standard Part Number:	Sil164CT64
Pb-Free Part Number:	Sil164CTG64 ('G' designates Pb-free packaging)



© 2002 Silicon Image, Inc. 09/02 SiI-DS-0021-D

Silicon Image, Inc.
1060 E. Arques Avenue
Sunnyvale, CA 94085
USA

Tel: (408) 616-4000
Fax: (408) 830-9530
E-mail: salesupport@SilImage.com
Web: www.siliconimage.com