



Power RF Amplifiers

Power = 30 Watts

Bandwidth = 450 to 470 Mhz

Gain = 25dB Vdd = 12.5 Volts

50 ohms Input/Output Impedance

Description

The PHM003 is a high gain high power amplifier design for the Tetra frequency range. It has two stages and uses the latest Ldmos technology transistors. The amplifier has very high gain and high efficiency and has a IP3 of 50 dBm

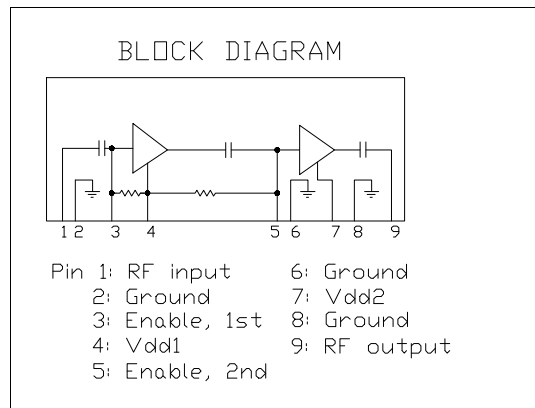
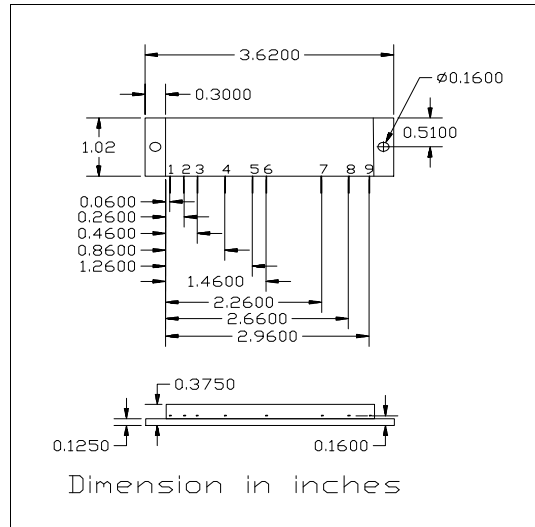

Absolute Maximum Ratings ( T = 25° C,

Parameter	Symbol	Value	Unit
DC supply Voltage	Vds	17	V
Input Power	Pin	0.13	W
Output Power	Pout	40	W
Operating Case Temp.	Tc	-20 to +70	°C
Storage Temp.	Tstg	-30 to +100	°C

Electrical Characteristics: ( T = 25° C Zs=Zl=50 ohms. Vdd =12.5 Volts )

Parameter	Symbol	Min	Typical	Max	Unit	Test Conditions
Frequency Range	BW	450		470	Mhz	50 ohm load
Output Power	Po	30			Watts	Idq = 0.7 Amps
Power Gain	PG	25			dB	@ Pout = 30 Watts
Total Efficiency	η	40			%	@ Pout = 30 Watts
2nd Harmonics	dso				dBc	@ Pout = 30 W. Freq = 460 Mhz
Intermod - 2 tone	Ip3	45			dBm	Freq = 460 Mhz
Load Mismatch Tolerance	VSWR	10:1			Relative	All Phase Angles

# PHM003

