

BTRS-9780-1590G / BTRS-9780-1590-SPG

1590 nm TX / 1510 nm RX , 3.3V / 2.5 Gbps **RoHS Compliant** Single-Fiber WDM Transceiver

FEATURES

- | Single Fiber WDM Transceiver
- | Speed up to 2.67 Gbps
- | 1590 nm DFB LD Transmitter
- | High Sensitivity 1510 nm APD Receiver
- | Distance Up to 40 km
- | Single +3.3 V Power Supply
- | RoHS Compliant
- | PECL Differential Inputs and Outputs
- | LVTTTL Signal Detect Output
- | Wave Solderable and Aqueous Washable
- | Class 1 Laser International Safety Standard IEC 60825 Compliant

APPLICATIONS

- | WDM OC-48 / STM-16 Links
- | SONET/SDH Equipment Interconnect
- | Fiber Channel Links

DESCRIPTION

The BTRS-9780-1590G series is high performance module for single fiber communications by using 1590 nm transmitter and 1510 nm receiver. The transmitter section uses a multiple quantum well 1590 nm DFB laser and is a class 1 laser compliant according to International Safety Standard IEC 60825. The receiver section uses an integrated 1510 nm detector preamplifier (IDP) mounted in an optical header and a limiting post-amplifier IC. A PECL logic interface simplifies interface to external circuitry. LV-TTL Signal Detect is used.

LASER SAFETY

This single mode transceiver is a Class 1 laser product. It complies with IEC 60825 and FDA 21 CFR 1040.10 and 1040.11. The transceiver must be operated within the specified temperature and voltage limits. The optical ports of the module shall be terminated with an optical connector or with a dust plug.

ORDER INFORMATION

P/No.	Speed (Gb/s)	Distance (km)	TX (nm)	RX (nm)	Voltage (V)	Package	Temp (°C)	TX Power (dBm)	RX Sens. (dBm)
BTRS-9780-1590G	2.5 / 1.25	80	1590 DFB	1510	3.3	2X5 SC	0 to 70	3 to -2	-28

Absolute Maximum Ratings					
Parameter	Symbol	Min	Max	Units	Notes
Storage Temperature	Tstg	-40	85	°C	
Operating Temperature	Topr	0	70	°C	Air flow 1m/sec
Soldering Temperature	---		260	°C	10 seconds on leads only
Power Supply Voltage	Vcc	0	3.6	V	
Input Voltage	---	GND	Vcc	V	
Output Current	Iout	0	30	mA	

Recommended Operating Conditions					
Parameter	Symbol	Min	Typ	Max	Units / Notes
Power Supply Voltage	Vcc	3.13	3.3	3.47	V
Power supply Current	Icc,TX+Icc,RX		220	280	mA
Operating Temperature	Topr	0		70	°C / air flow 1m/sec
Data Rate		0.622	2.488	2.67	Gb/s

Transmitter Specifications (0°C < Topr < 70°C, 3.13V < Vcc < 3.47V)						
Parameter	Symbol	Min	Typ	Max	Units	Notes
Optical						
Optical Transmit Power	P _o	-2		3	dBm	1
Output Center Wavelength	λ	1580		1620	nm	
Output Spectrum Width	σ _λ			1	nm	RMS (σ)
Side Mode Suppression Ratio	SMSR	30			dB	
Extinction Ratio	E _R	8.2			dB	
Output Eye	Compliant with IEEE 802.3z					
Optical Rise Time	t _r			150	ps	20% to 80% Values
Optical Fall Time	t _f			150	ps	20% to 80% Values
Relative Intensity Noise	RIN			-120	dB/Hz	
Total Jitter	TJ			0.227	ns	2
Electrical						
Data Input Current -- Low	I _{IL}	-350			μA	
Data Input Current -- High	I _{IH}			350	μA	
Differential Input Voltage	V _{IH} - V _{IL}	300		1600	mV	
Data Input Voltage -- Low	V _{IL} - V _{CC}	-2.0		-1.58	V	3
Data Input Voltage -- High	V _{IH} - V _{CC}	-1.1		-0.74	V	3
Disable Input Voltage -- Low	V _{TDIS,L}	0		0.8	V	TX Output Enabled
Disable Input Voltage -- High	V _{TDIS,H}	V _{CC} - 1.3		V _{CC}	V	TX Output Disabled
Shut Off Time for TxDis	t _{DIS}			1	ms	

- Notes: 1. Output power is power coupled into a 9/125 μm single mode fiber.
 2. Measured with a 2⁷-1 PRBS.
 3. These inputs are compatible with 10K, 10KH and 100K ECL and LVPECL inputs.

Receiver Specifications (0°C < Topr < 70°C, 3.13 V < Vcc < 3.47V)						
Parameter	Symbol	Min	Typ	Max	Units	Notes
Optical						
Sensitivity	---	---	---	-28	dBm	1
Maximum Input Power	P _{in}	-9	---	---	dBm	
Signal Detect -- Asserted	P _a	---	---	-28	dBm	Transition: low to high
Signal Detect -- Deasserted	P _d	-45	---	---	dBm	Transition: high to low
Signal detect -- Hysteresis		1.0	---		dB	
Wavelength of Operation		1480		1520	nm	2
Optical Return Loss	ORL	20			dB	
Electrical						
Data Output Voltage Swing	V _{OH} - V _{OL}	0.575		0.930	V	
SD Output Voltage -- Low	V _{OL}	0		0.8	V	
SD Output Voltage -- High	V _{OH}	2.0		V _{CC} +0.3	V	
Signal Detect Assert Time	A _S MAX			100	μs	OFF to ON
Signal Detect Deassert Time	A _N MAX			300	μs	ON to OFF

- Notes: 1. Minimum sensitivity and saturation levels at BER 1E-10 for a 2²³-1 PRBS.
 2. At least 30 dB optical isolation for the wavelength 1580 to 1620 nm.

CONNECTION DIAGRAM



PIN	Symbol	Notes
1	V_{EEf}	Directly connect this pin to the receiver ground plane
2	V_{CCf}	+3.3V dc power for the receiver section
3	SD	Active high on this indicates a received optical signal.
4	RD-	Receiver Dataout Bar. See recommended circuit schematic
5	RD+	Receiver Dataout. See recommended circuit schematic
6	V_{CCt}	+3.3V dc power for the transmitter section
7	V_{EEt}	Directly connect this plan to the transmitter ground plane
8	TxDis	Transmitter Disable. Connect this pin to +3.3V TTL logic "1" to disable module To enable module connect to TTL logic low "0"
9	TD+	Transmitter Data In. See recommended circuit schematic
10	TD-	Transmitter Data In Bar. See recommended circuit schematic
MS	MS	Mounting Studs. Connect to Chassis Ground

RECOMMENDED CIRCUIT SCHEMATIC

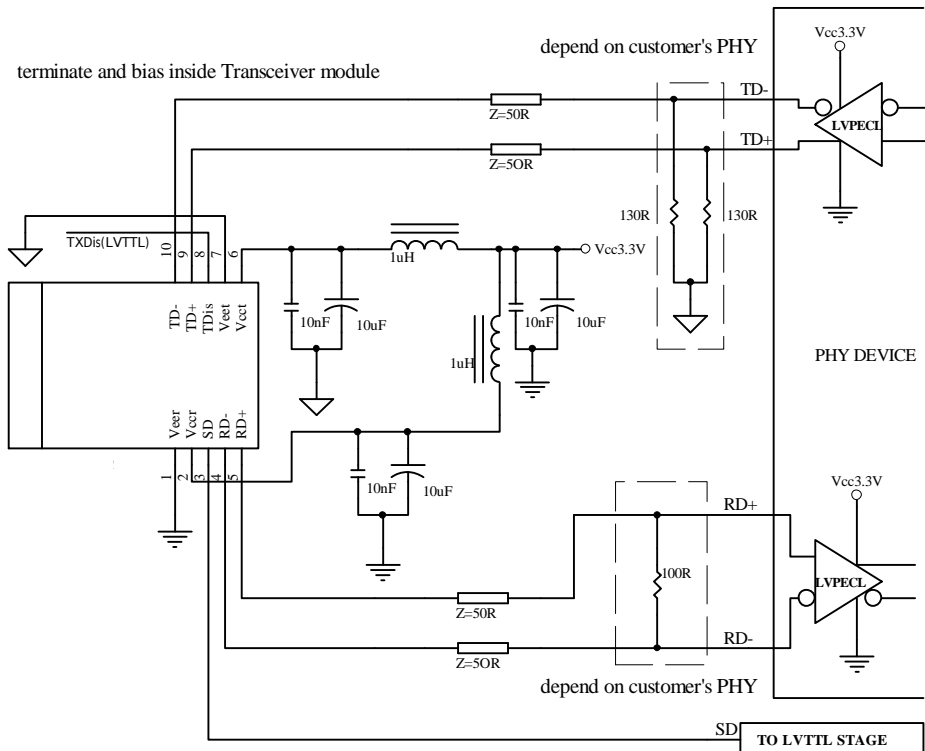

PACKAGE DIAGRAM

Units in mm

1) SC Receptacle

A) Standard Case

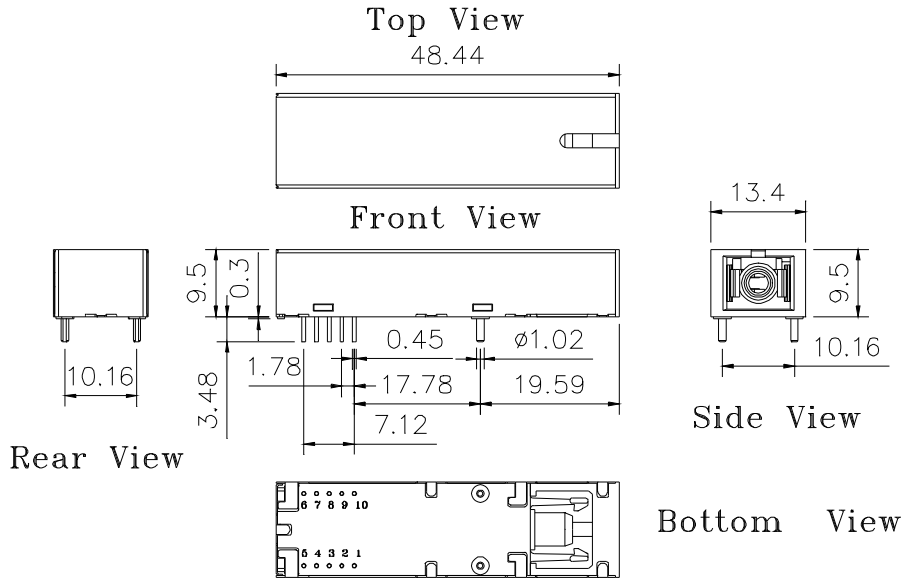

BTRS-9780-1590G

B) Extended Case

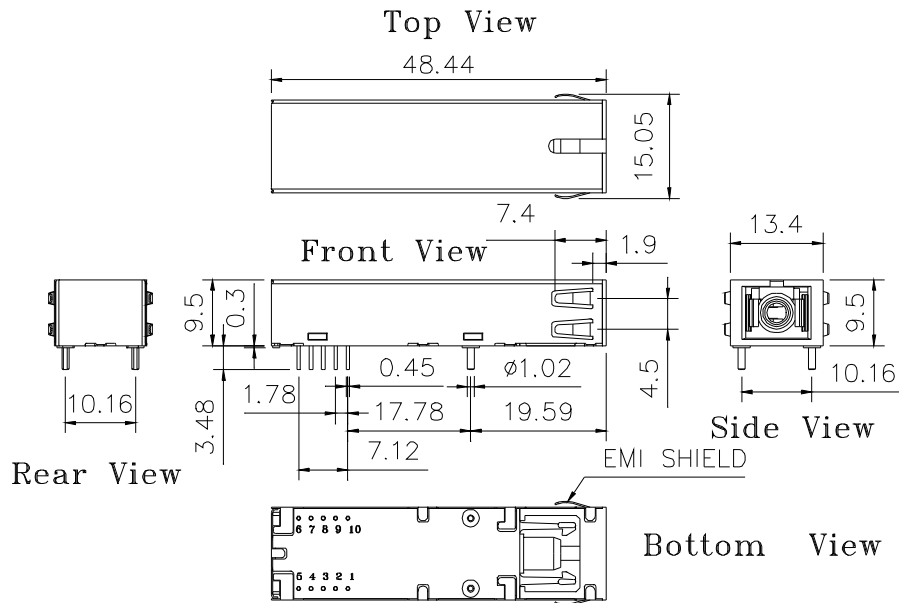

BTRS-9780-1590EG

2) Pigtail

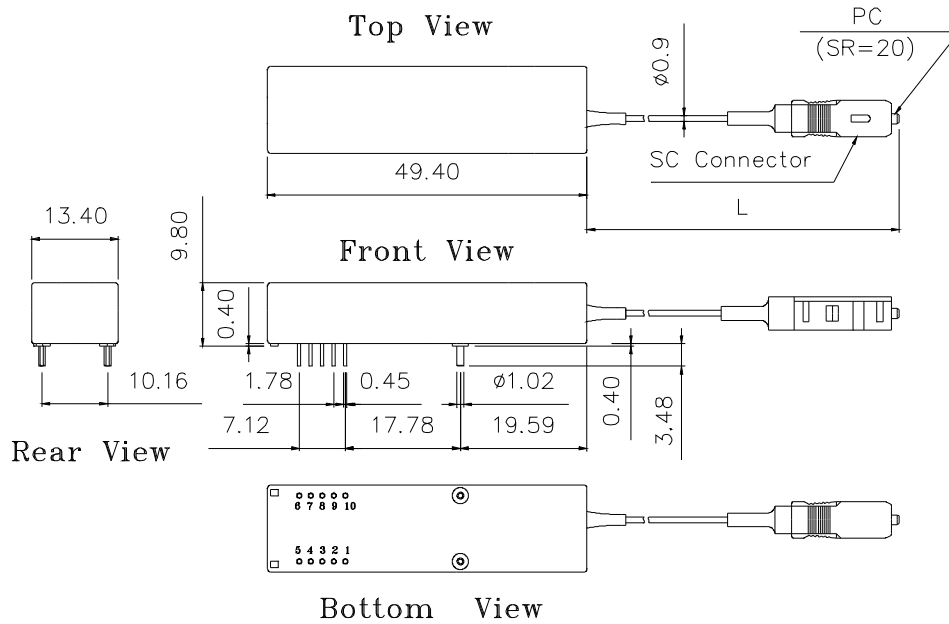

BTRS-9780-1590-SP50G

Note: Length L is 50 ± 3 cm. Other pigtail's length is available upon request.

Note: Specifications subject to change without notice.