

MEMORY

Un-buffered

2 M × 64 BIT SYNCHRONOUS DYNAMIC RAM SO-DIMM

MB8502S064AD-100/-84/-67

144-pin, 1 clock, 1-bank, based on 2 M × 8 BIT SDRAMs with SPD

DESCRIPTION

The Fujitsu MB8502S064AD is a fully decoded, CMOS Synchronous Dynamic Random Access Memory (SDRAM) Module consisting of eight MB81117822A devices which organized as two banks of 2 M × 8 bits and a 2K-bit serial EEPROM on a 144-pin glass-epoxy substrate.

The MB8502S064AD features a fully synchronous operation referenced to a positive edge clock whereby all operations are synchronized at a clock input which enables high performance and simple user interface coexistence.

The MB8502S064AD is optimized for those applications requiring high speed, high performance and large memory storage, and high density memory organizations.

This module is ideally suited for workstations, PCs, laser printers, and other applications where a simple interface is needed.

PRODUCT LINE & FEATURES

| Parameter | | MB8502S064AD-100 | MB8502S064AD-84 | MB8502S064AD-67 |
|-------------------------|-----------------|--------------------------------------------|--------------------------------------------|--------------------------------------------|
| Clock Frequency | | 100 MHz max. | 84 MHz max. | 67 MHz max. |
| Burst Mode Cycle Time | | 10 ns max. (CL = 3) 15 ns max. (CL = 2) | 12 ns max. (CL = 3) 17 ns max. (CL = 2) | 15 ns max. (CL = 3) 20 ns max. (CL = 2) |
| RAS Access Time | | 54 ns max. | 56 ns max. | 60 ns max. |
| CAS Access Time | | 24 ns max. | 26 ns max. | 30 ns max. |
| Output Valid from Clock | | 8.5 ns max. (CL = 3) 9 ns max. (CL = 2) | 8.5 ns max. (CL = 3) 9 ns max. (CL = 2) | 9 ns max. (CL = 3) 10 ns max. (CL = 2) |
| Power Dissipation | Burst Mode | 3888 mW max. | 3600 mW max. | 3312 mW max. |
| | Power Down Mode | 57.6 mW max. | | |

- Un-buffered 144-pin DIMM Socket Type (Lead pitch : 0.8 mm)
- Conformed to JEDEC Standard (1 CLK)
- Organization : 2,097,152 words × 64 bits
- Memory : MB81117822A (2 M × 8, 2-bank) × 8 pcs.
- 3.3 V ± 0.3 V Supply Voltage
- All input/output LVTTTL compatible
- 2048 Refresh Cycle every 32.8 ms
- Auto and Self Refresh
- CKE Power Down Mode
- DQM Byte Masking (Read/Write)
- Serial Presence Detect (SPD) with Serial EEPROM
- Module size : 1.0" (height) × 2.66" (length) × 0.15" (thick)

MB8502S064AD-100/-84/-67

■ PACKAGE

Plastic DIMM Package

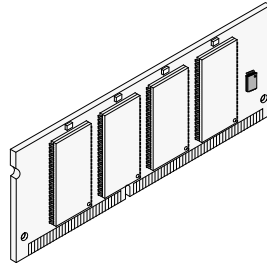

(MDS-144P-P04)

Package and Ordering Information

– 144-pin SO-DIMM, order as MB8502S064AD-xxDG (DG=Gold Pad)

MB8502S064AD-100/-84/-67

■ PIN ASSIGNMENTS

| Pin No. | Signal Name | Pin No. | Signal Name | Pin No. | Signal Name | Pin No. | Signal Name | Pin No. | Signal Name | Pin No. | Signal Name |
|---------|-------------------|---------|--------------------------|---------|-------------------|---------|-------------------|---------|-------------------------|---------|-------------------|
| 1 | V _{SS} | 49 | DQ ₁₃ | 97 | DQ ₂₂ | 2 | V _{SS} | 50 | DQ ₄₅ | 98 | DQ ₅₄ |
| 3 | DQ ₀ | 51 | DQ ₁₄ | 99 | DQ ₂₃ | 4 | DQ ₃₂ | 52 | DQ ₄₆ | 100 | DQ ₅₅ |
| 5 | DQ ₁ | 53 | DQ ₁₅ | 101 | V _{CC} | 6 | DQ ₃₃ | 54 | DQ ₄₇ | 102 | V _{CC} |
| 7 | DQ ₂ | 55 | V _{SS} | 103 | A ₆ | 8 | DQ ₃₄ | 56 | V _{SS} | 104 | A ₇ |
| 9 | DQ ₃ | 57 | N.C. | 105 | A ₈ | 10 | DQ ₃₅ | 58 | N.C. | 106 | A ₁₁ |
| 11 | V _{CC} | 59 | N.C. | 107 | V _{SS} | 12 | V _{CC} | 60 | N.C. | 108 | V _{SS} |
| 13 | DQ ₄ | 61 | CLK | 109 | A ₉ | 14 | DQ ₃₆ | 62 | CKE | 110 | N.C. |
| 15 | DQ ₅ | 63 | V _{CC} | 111 | A ₁₀ | 16 | DQ ₃₇ | 64 | V _{CC} | 112 | N.C. |
| 17 | DQ ₆ | 65 | $\overline{\text{RAS}}$ | 113 | V _{CC} | 18 | DQ ₃₈ | 66 | $\overline{\text{CAS}}$ | 114 | V _{CC} |
| 19 | DQ ₇ | 67 | $\overline{\text{WE}}$ | 115 | DQMB ₂ | 20 | DQ ₃₉ | 68 | N.C. | 116 | DQMB ₆ |
| 21 | V _{SS} | 69 | $\overline{\text{CS}}_0$ | 117 | DQMB ₃ | 22 | V _{SS} | 70 | N.C. | 118 | DQMB ₇ |
| 23 | DQMB ₀ | 71 | N.C. | 119 | V _{SS} | 24 | DQMB ₄ | 72 | N.C. | 120 | V _{SS} |
| 25 | DQMB ₁ | 73 | N.C. | 121 | DQ ₂₄ | 26 | DQMB ₅ | 74 | N.C. | 122 | DQ ₅₆ |
| 27 | V _{CC} | 75 | V _{SS} | 123 | DQ ₂₅ | 28 | V _{CC} | 76 | V _{SS} | 124 | DQ ₅₇ |
| 29 | A ₀ | 77 | N.C. | 125 | DQ ₂₆ | 30 | A ₃ | 78 | N.C. | 126 | DQ ₅₈ |
| 31 | A ₁ | 79 | N.C. | 127 | DQ ₂₇ | 32 | A ₄ | 80 | N.C. | 128 | DQ ₅₉ |
| 33 | A ₂ | 81 | V _{CC} | 129 | V _{CC} | 34 | A ₅ | 82 | V _{CC} | 130 | V _{CC} |
| 35 | V _{SS} | 83 | DQ ₁₆ | 131 | DQ ₂₈ | 36 | V _{SS} | 84 | DQ ₄₈ | 132 | DQ ₆₀ |
| 37 | DQ ₈ | 85 | DQ ₁₇ | 133 | DQ ₂₉ | 38 | DQ ₄₀ | 86 | DQ ₄₉ | 134 | DQ ₆₁ |
| 39 | DQ ₉ | 87 | DQ ₁₈ | 135 | DQ ₃₀ | 40 | DQ ₄₁ | 88 | DQ ₅₀ | 136 | DQ ₆₂ |
| 41 | DQ ₁₀ | 89 | DQ ₁₉ | 137 | DQ ₃₁ | 42 | DQ ₄₂ | 90 | DQ ₅₁ | 138 | DQ ₆₃ |
| 43 | DQ ₁₁ | 91 | V _{SS} | 139 | V _{SS} | 44 | DQ ₄₃ | 92 | V _{SS} | 140 | V _{SS} |
| 45 | V _{CC} | 93 | DQ ₂₀ | 141 | SDA | 46 | V _{CC} | 94 | DQ ₅₂ | 142 | SCL |
| 47 | DQ ₁₂ | 95 | DQ ₂₁ | 143 | V _{CC} | 48 | DQ ₄₄ | 96 | DQ ₅₃ | 144 | V _{CC} |

MB8502S064AD-100/-84/-67

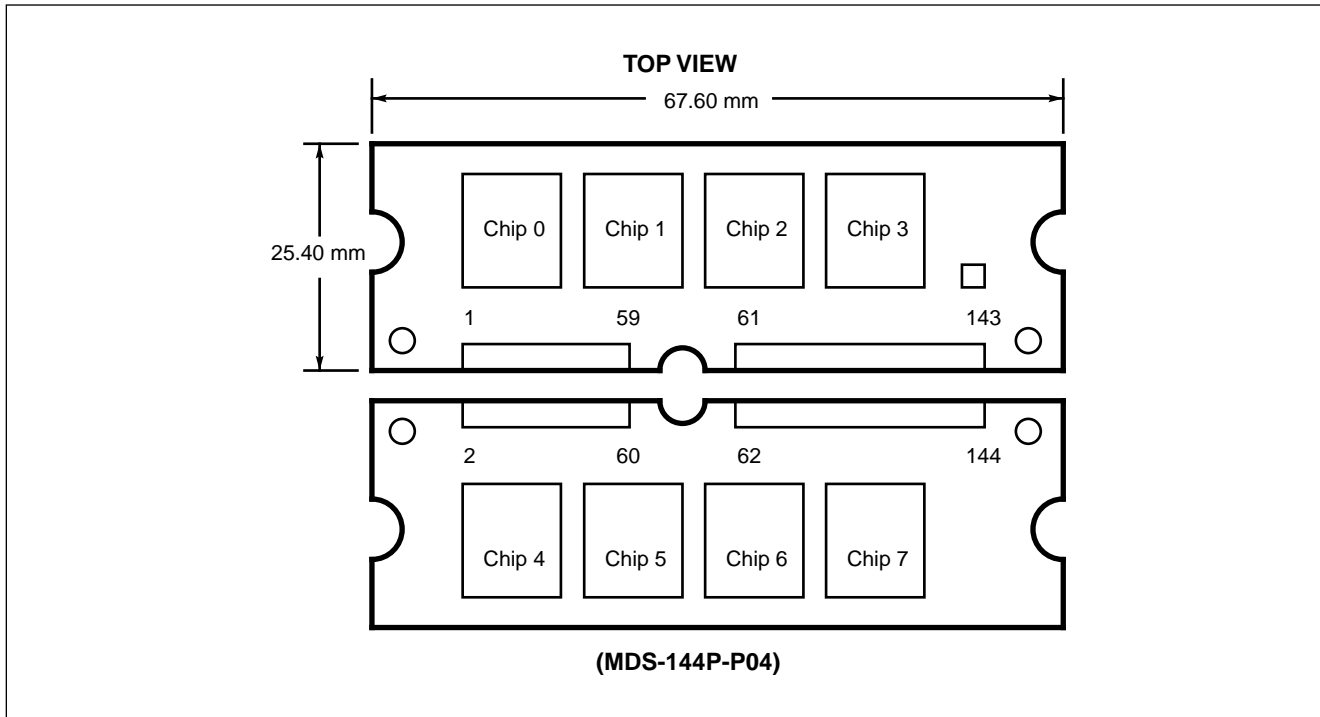

■ PIN DESCRIPTIONS

| Symbol | I/O | Function | Symbol | I/O | Function |
|----------------------------------------|-----|-----------------------|-------------------------------------|-----|-------------------------------------|
| A ₀ to A ₁₁ | I | Address Input | \overline{CS}_0 | I | Chip Select |
| \overline{RAS} | I | Row Address Strobe | DQ ₀ to DQ ₆₃ | I/O | Data Input/Data Output |
| \overline{CAS} | I | Column Address Strobe | V _{CC} | — | Power Supply (+3.3 V) |
| \overline{WE} | I | Write Enable | V _{SS} | — | Ground (0 V) |
| DQMB ₀ to DQMB ₇ | I | Data (DQ) Mask | N.C. | — | No Connection |
| CLK | I | Clock Input | SCL | I | Serial PD Clock |
| CKE | I | Clock Enable | SDA | I/O | Serial PD Address/Data Input/Output |

■ SERIAL-PD INFORMATION

| Byte | Function Described | | Bit7 | Bit6 | Bit5 | Bit4 | Bit3 | Bit2 | Bit1 | Bit0 |
|-----------|--------------------------------------------------------------------------|------------|------|------|------|------|------|------|------|------|
| 0 | Defines Number of Bytes Written into Serial Memory at Module Manufacture | 128 Byte | 1 | 0 | 0 | 0 | 0 | 0 | 0 | 0 |
| 1 | Total Number of Bytes of SPD Memory | 256 Byte | 0 | 0 | 0 | 0 | 1 | 0 | 0 | 0 |
| 2 | Fundamental Memory Type | SDRAM | 0 | 0 | 0 | 0 | 0 | 1 | 0 | 0 |
| 3 | Number of Row Addresses | 11 | 0 | 0 | 0 | 0 | 1 | 0 | 1 | 1 |
| 4 | Number of Column Addresses | 9 | 0 | 0 | 0 | 0 | 1 | 0 | 0 | 1 |
| 5 | Number of Module Banks | 1 bank | 0 | 0 | 0 | 0 | 0 | 0 | 0 | 1 |
| 6 | Data Width | 64 bit | 0 | 1 | 0 | 0 | 0 | 0 | 0 | 0 |
| 7 | Data Width (Continuation) | +0 | 0 | 0 | 0 | 0 | 0 | 0 | 0 | 0 |
| 8 | Interface Type | LVTTL | 0 | 0 | 0 | 0 | 0 | 0 | 0 | 1 |
| 9 | SDRAM Cycle time | 10 ns | 1 | 0 | 1 | 0 | 0 | 0 | 0 | 0 |
| | | 12 ns | 1 | 1 | 0 | 0 | 0 | 0 | 0 | 0 |
| | | 15 ns | 1 | 1 | 1 | 1 | 0 | 0 | 0 | 0 |
| 10 | SDRAM Access from Clock | 8.5 ns | 1 | 0 | 0 | 0 | 0 | 1 | 0 | 1 |
| | | 9 ns | 1 | 0 | 0 | 1 | 0 | 0 | 0 | 0 |
| 11 | DIMM Configuration Type | Non-Parity | 0 | 0 | 0 | 0 | 0 | 0 | 0 | 0 |
| 12 | Refresh Rate/Type | Self, Norm | 1 | 0 | 0 | 0 | 0 | 0 | 0 | 0 |
| 13 | SDRAM Module Attributes | UN-Buffer | 0 | 0 | 0 | 0 | 0 | 0 | 0 | 0 |
| 14 | SDRAM Device Attributes | (*) | 0 | 0 | 0 | 0 | 0 | 1 | 1 | 0 |
| 15 | Minimum Clock Delay Back to Back Random Column Address | 1 Cycle | 0 | 0 | 0 | 0 | 0 | 0 | 0 | 1 |
| 16 | Burst Lengths Supported | 1, 2, 4, 8 | 0 | 0 | 0 | 0 | 1 | 1 | 1 | 1 |
| 17 | Number of Banks on Each SDRAM Device | 2 bank | 0 | 0 | 0 | 0 | 0 | 0 | 1 | 0 |
| 18 | CAS Latency | 2, 3 | 0 | 0 | 0 | 0 | 0 | 1 | 1 | 0 |
| 19 | CS Latency | 0 | 0 | 0 | 0 | 0 | 0 | 0 | 0 | 1 |
| 20 | Write Latency | 0 | 0 | 0 | 0 | 0 | 0 | 0 | 0 | 1 |
| 21 to 31 | Reserved for Future Offerings | – | 0 | 0 | 0 | 0 | 0 | 0 | 0 | 0 |
| 32 to 63 | Superset Information | – | 0 | 0 | 0 | 0 | 0 | 0 | 0 | 0 |
| 64 to 127 | Manufacturer's Information | – | 0 | 0 | 0 | 0 | 0 | 0 | 0 | 0 |
| 128+ | Unused Storage Locations | – | – | – | – | – | – | – | – | – |

Note: Any write operation must NOT be executed into the addresses of Byte 0 to Byte 127. Some or all data stored into Byte 0 to Byte 127 may be broken.

(*) Byte 14 : SDRAM Device Attributes

| Bit7 | Bit6 | Bit5 | Bit4 | Bit3 | Bit2 | Bit1 | Bit0 |
|------|------|------|------|---------------------------------------|----------------------------|------------------------------|----------------------------------|
| TBD | TBD | TBD | TBD | Supported Single Write/ Burst Read | Supported Precharge All | Supported Auto- Precharge | Supported Early RAS Precharge |
| 0 | 0 | 0 | 0 | 0 | 1 | 1 | 0 |

MB8502S064AD-100/-84/-67

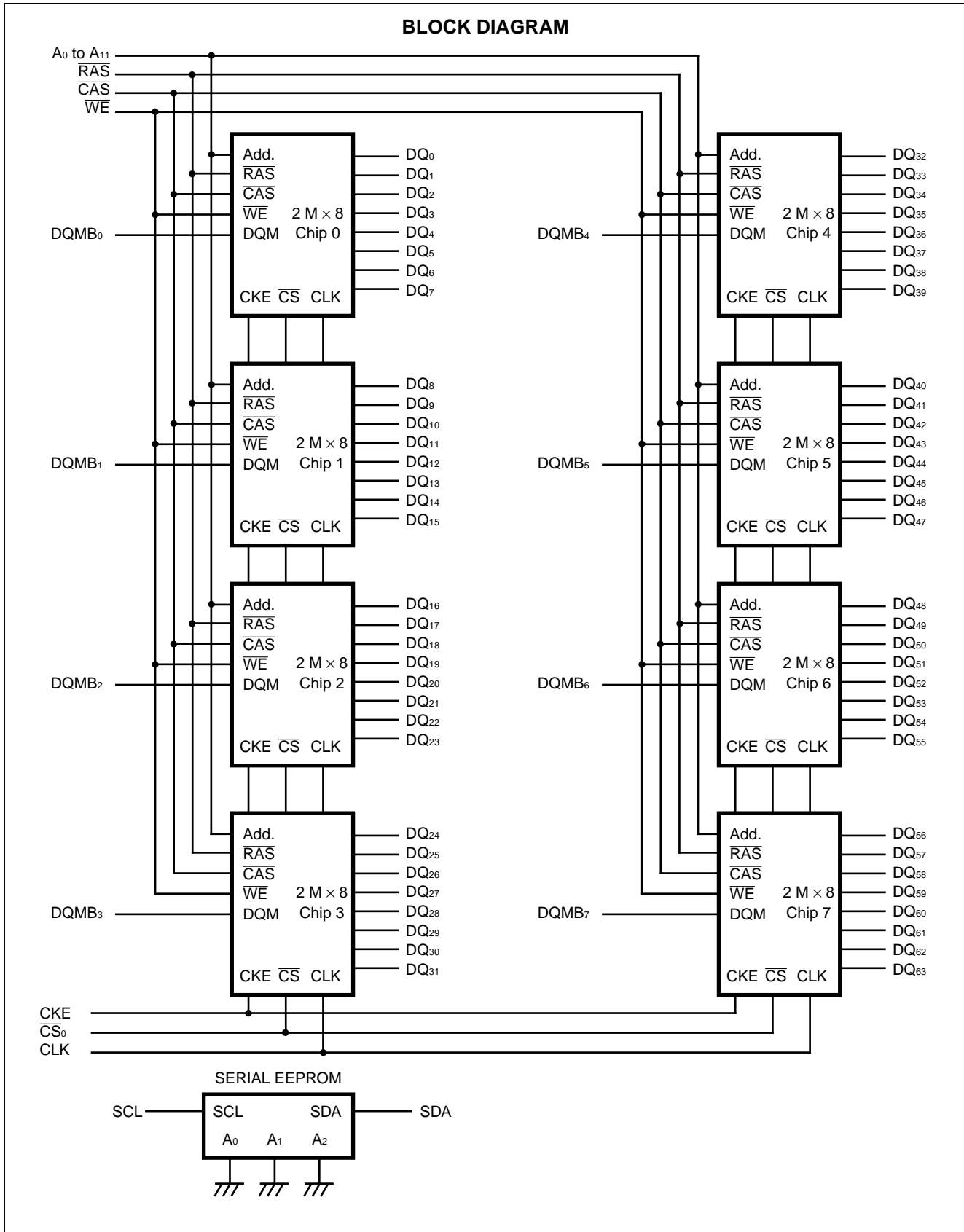

MB8502S064AD-100/-84/-67

■ ABSOLUTE MAXIMUM RATINGS (See WARNING)

| Parameter | Symbol | Value | | Unit |
|-----------------------|------------------|-------|------|------|
| | | Min. | Max. | |
| Supply Voltage* | V _{CC} | -0.5 | +4.6 | V |
| Input Voltage* | V _{IN} | -0.5 | +4.6 | V |
| Output Voltage* | V _{OUT} | -0.5 | +4.6 | V |
| Storage Temperature | T _{STG} | -55 | +125 | °C |
| Power Dissipation | P _D | — | 10.4 | W |
| Output Current (D.C.) | I _{OUT} | -50 | +50 | mA |

* : Voltages referenced to V_{SS} (= 0 V)

WARNING: Semiconductor devices can be permanently damaged by application of stress (voltage, current, temperature, etc.) in excess of absolute maximum ratings. Do not exceed these ratings.

■ RECOMMENDED OPERATING CONDITIONS

| Parameter | Notes | Symbol | Value | | | Unit |
|--------------------------------|-------|-----------------|-------|------|-----------------------|------|
| | | | Min. | Typ. | Max. | |
| Supply Voltage | *1 | V _{CC} | 3.0 | 3.3 | 3.6 | V |
| | | V _{SS} | 0 | 0 | 0 | V |
| Input High Voltage, All Inputs | *1 | V _{IH} | 2.0 | — | V _{CC} + 0.5 | V |
| Input Low Voltage, All Inputs | *1, 2 | V _{IL} | -0.5 | — | 0.8 | V |
| Ambient Temperature | | T _A | 0 | — | +70 | °C |

*1. Voltages referenced to V_{SS} (= 0 V)

*2. V_{IL} (min) = -1.5 V AC (Pulse Width ≤ 5 ns)

WARNING: Recommended operating conditions are normal operating ranges for the semiconductor device. All the device's electrical characteristics are warranted when operated within these ranges.

Always use semiconductor devices within the recommended operating conditions. Operation outside these ranges may adversely affect reliability and could result in device failure.

No warranty is made with respect to uses, operating conditions, or combinations not represented on the data sheet. Users considering application outside the listed conditions are advised to contact their FUJITSU representative beforehand.

MB8502S064AD-100/-84/-67

■ CAPACITANCE

($V_{CC} = +3.3\text{ V}$, $f = 1\text{ MHz}$, $T_A = +25^\circ\text{C}$)

| Parameter | | Symbol | Value | | Unit |
|--------------------------|-------------------------------------------------------|-----------|-------|------|------|
| | | | Min. | Max. | |
| Input Capacitance | A_0 to A_{11} | C_{IN1} | — | 33 | pF |
| | \overline{RAS} , \overline{CAS} , \overline{WE} | C_{IN2} | — | 31 | pF |
| | \overline{CS}_0 , \overline{CS}_2 | C_{IN3} | — | 39 | pF |
| | CKE | C_{IN4} | — | 33 | pF |
| | CLK | C_{IN5} | — | 32 | pF |
| | $DQMB_0$ to $DQMB_7$ | C_{IN6} | — | 9 | pF |
| | SCL | C_{SCL} | — | 5 | pF |
| Input/Output Capacitance | SDA | C_{SDA} | — | 5 | pF |
| | DQ_0 to DQ_{63} | C_{DQ} | — | 11 | pF |

MB8502S064AD-100/-84/-67

■ DC CHARACTERISTICS

(At recommended operating conditions unless otherwise noted.)

| Parameter | Notes | Symbol | Test Condition | Value | | Unit | | |
|-----------------------------------------------------------|------------------|------------------|-----------------------------------------------------------------------------------------------------------|------------------------------------------------------------------------|------|-----------------|-----|----|
| | | | | Min. | Max. | | | |
| Operating Current (Average Power Supply Current) | *2 | MB8502S064AD-100 | No Burst; $t_{CK} = \min$ $t_{RC} = \min$ One Bank Active | — | 680 | mA | | |
| | | MB8502S064AD-84 | | | 640 | mA | | |
| | | MB8502S064AD-67 | | | 600 | mA | | |
| | MB8502S064AD-100 | *2 | MB8502S064AD-100 | No Burst; $t_{CK} = \min$ $t_{RC} = \min$ All Banks Active | — | 1040 | mA | |
| | | | | | | MB8502S064AD-84 | 960 | mA |
| | | | | | | MB8502S064AD-67 | 880 | mA |
| Precharge Standby Current (Power Supply Current) | *2 | I_{CC2P} | CKE = V_{IL} , $t_{CK} = \min$ All Banks Idle | — | 16 | mA | | |
| | | I_{CC2N} | CKE = V_{IH} , $t_{CK} = \min$ All Banks Idle | — | 240 | mA | | |
| Active Standby Current (Power Supply Current) | *2 | I_{CC3P} | CKE = V_{IL} , $t_{CK} = \min$ Any Bank Active | — | 240 | mA | | |
| | | I_{CC3N} | CKE = V_{IH} , $t_{CK} = \min$ Any Bank Active | — | 400 | mA | | |
| Burst Mode Current (Average Power Supply Current) | *2 | MB8502S064AD-100 | I_{CC4} | $t_{CK} = \min$ | — | 1080 | mA | |
| | | MB8502S064AD-84 | | | — | 1000 | mA | |
| | | MB8502S064AD-67 | | | — | 920 | mA | |
| Auto-Refresh Current (Average Power Supply Current) | *2 | MB8502S064AD-100 | I_{CC5} | Auto Refresh $t_{CK} = \min$ $t_{RC} = \min$ $t_{RRD} = \min$ | — | 880 | mA | |
| | | MB8502S064AD-84 | | | — | 800 | mA | |
| | | MB8502S064AD-67 | | | — | 720 | mA | |
| Self-Refresh Current (Average Power Supply Current) | | I_{CC6} | $t_{CK} = V_{IL}$ | — | 16 | mA | | |
| Input Leakage Current (All Inputs) | | $I_{I(L)}$ | $0 V \leq V_{IN} \leq V_{CC}$ All other pins not under test = 0 V $3.0 V \leq V_{CC} \leq 3.6 V$ | -50 | 50 | μA | | |
| Output Leakage Current | | $I_{O(L)}$ | Output is disabled (Hi-Z) $0 V \leq V_{OUT} \leq V_{CC}$ $3.0 V \leq V_{CC} \leq 3.6 V$ | -10 | 10 | μA | | |
| LVTTL Output High Voltage | *1 | V_{OH} | $I_{OH} = -2.0 \text{ mA}$ | 2.4 | — | V | | |
| LVTTL Output Low Voltage | *1 | V_{OL} | $I_{OL} = +2.0 \text{ mA}$ | — | 0.4 | V | | |

Notes: *1. Voltages referenced to V_{SS} (= 0 V)

*2. I_{CC} depends on the output termination, load conditions, clock cycle rate and signal clock rate.
The specified values are obtained with the output open and no termination register.

*3. An initial pause (DESL on NOP) of 200 μs is required after power-on followed by a minimum of eight Auto-refresh cycles.

*4. DC characteristics is the Serial PD standby state ($V_{IN} = GND$ or V_{CC}).

MB8502S064AD-100/-84/-67

■ AC CHARACTERISTICS

(1) BASE CHARACTERISTICS

(At recommended operating conditions unless otherwise noted.)

| No. | Parameter | Notes | Symbol | MB8502S064AD -100 | | MB8502S064AD -84 | | MB8502S064AD -67 | | Unit |
|-----|-----------------------------------------------------|------------------|------------------|----------------------|------|---------------------|------|---------------------|------|------|
| | | | | Min. | Max. | Min. | Max. | Min. | Max. | |
| 1 | Clock Period | CL = 3 | t _{CK} | 10 | — | 12 | — | 15 | — | ns |
| | | CL = 2 | | 15 | — | 17 | — | 20 | — | ns |
| 2 | Clock High Time | | t _{CH} | 4 | — | 4 | — | 4 | — | ns |
| 3 | Clock Low Time | | t _{CL} | 4 | — | 4 | — | 4 | — | ns |
| 4 | $\overline{\text{CS}}$ Set Up Time | | t _{SC} | 3 | — | 3 | — | 3 | — | ns |
| 5 | $\overline{\text{CS}}$ Hold Time | | t _{HC} | 1 | — | 1 | — | 1 | — | ns |
| 6 | Input Set Up Time | | t _{SI} | 3 | — | 3 | — | 3 | — | ns |
| 7 | Input Hold Time | | t _{HI} | 1 | — | 1 | — | 1 | — | ns |
| 8 | Data Input Set Up Time | | t _{SID} | 3 | — | 3 | — | 3 | — | ns |
| 9 | Data Input Hold Time | | t _{HID} | 1 | — | 1 | — | 1 | — | ns |
| 10 | Output Valid from Clock (t _{CLK} = min) | *1, *2 CL = 3 | t _{AC} | — | 8.5 | — | 8.5 | — | 9 | ns |
| | | CL = 2 | | — | 9 | — | 9 | — | 10 | |
| 11 | Output in Low-Z | | t _{OLZ} | 3 | — | 3 | — | 3 | — | ns |
| 12 | Output in High-Z | *3 | t _{OHZ} | 3 | — | 3 | — | 3 | — | ns |
| 13 | Output Hold Time | | t _{OH} | 3 | — | 3 | — | 3 | — | ns |
| 14 | Time between Refresh | | t _{REF} | — | 32.8 | — | 32.8 | — | 32.8 | ms |
| 15 | Transition Time | | t _T | 0.5 | 2 | 0.5 | 2 | 0.5 | 2 | ns |
| 16 | Power Down Exit Time | | t _{PDE} | 3 | — | 4 | — | 5 | — | ns |

MB8502S064AD-100/-84/-67

(2) BASE VALUES FOR CLOCK COUNT/LATENCY

| No. | Parameter | Notes | Symbol | MB8502S064AD -100 | | MB8502S064AD -84 | | MB8502S064AD -67 | | Unit |
|-----|-----------------------------------|--------|------------------|----------------------|--------|---------------------|--------|---------------------|--------|------|
| | | | | Min. | Max. | Min. | Max. | Min.. | Max. | |
| 1 | RAS Cycle Time | *4 | t _{RC} | 90 | — | 100 | — | 110 | — | ns |
| 2 | RAS Access Time | *5 | t _{RAC} | — | 54 | — | 56 | — | 60 | ns |
| 3 | CAS Access Time | *6, *9 | t _{CAC} | — | 24 | — | 26 | — | 30 | ns |
| 4 | RAS Precharge Time | | t _{RP} | 30 | — | 35 | — | 40 | — | ns |
| 5 | RAS Active Time | | t _{RAS} | 60 | 100000 | 65 | 100000 | 70 | 100000 | ns |
| 6 | RAS to CAS Delay Time | *7 | t _{RCD} | 30 | — | 30 | — | 30 | — | ns |
| 7 | Write Recovery Time | | t _{WR} | 10 | — | 12 | — | 15 | — | ns |
| 8 | Write Precharge Time | | t _{RWL} | 10 | — | 12 | — | 15 | — | ns |
| 9 | RAS to RAS Bank Active Delay Time | | t _{RRD} | 30 | — | 30 | — | 30 | — | ns |

(3) CLOCK COUNT FORMULA (*8)

$$\text{Clock} \geq \frac{\text{Base Value}}{\text{Clock Period}} \quad (\text{Round off a whole number})$$

(4) LATENCY (The latency values on these parameters are fixed regardless of clock period.)

| No. | Parameter | Symbol | MB8502S064AD -100 | MB8502S064AD -84 | MB8502S064AD -67 | Unit |
|-----|-------------------------------------------|-------------------|----------------------|---------------------|---------------------|-------|
| 1 | CKE to Clock Disable | t _{CKE} | 1 | 1 | 1 | Cycle |
| 2 | DQM to Output in High-Z | t _{DQZ} | 2 | 2 | 2 | Cycle |
| 3 | DQM to Input Data Delay | t _{DQD} | 0 | 0 | 0 | Cycle |
| 4 | Last Output to Write Command Delay | t _{LOWD} | 2 | 2 | 2 | Cycle |
| 5 | Write Command to Input Data Delay | t _{DWD} | 0 | 0 | 0 | Cycle |
| 6 | Precharge to Output in High-Z Delay | CL = 3 | 3 | 3 | 3 | Cycle |
| | | CL = 2 | 2 | 2 | 2 | Cycle |
| 7 | Mode Register Access to Bank Active (min) | t _{MRD} | 2 | 2 | 2 | Cycle |
| 8 | CAS to CAS Delay (min) | t _{CCD} | 1 | 1 | 1 | Cycle |
| 9 | CAS Bank Delay (min) | t _{CBD} | 1 | 1 | 1 | Cycle |

MB8502S064AD-100/-84/-67

- Notes:**
- *1. Assumes t_{RCD} and t_{CAC} are satisfied.
 - *2. t_{AC} also specifies the access time at burst mode except for first access.
 - *3. Specified where output buffer is no longer driven.
 - *4. Actual clock count of t_{RC} (I_{RC}) will be sum of clock count of t_{RAS} (I_{RAS}) and t_{RP} (I_{RP}).
 - *5. t_{RAC} is a reference value. Maximum value is obtained from the sum of t_{RCD} (min) and t_{CAC} (max).
 - *6. Assumes t_{RAC} and t_{AC} are satisfied.
 - *7. Operation within the t_{RCD} (min) ensures that t_{RAC} can be met; if t_{RCD} is greater than the specified t_{RCD} (min), access time is determined by t_{CAC} and t_{AC} .
 - *8. All base values are measured from the clock edge at the command input to the clock edge for the next command input.
All clock counts are calculated by a simple formula :
clock count equals base value divided by clock period (round off to a whole number).
 - *9. The I_{CAC} (CAS latency : CL) is programmed by the mode register.
 - *10. An initial pause (DESL on NOP) of 200 μ s is required after power-up followed by a minimum of eight Auto-refresh cycles.
 - *11. 1.4 V or V_{REF} is the reference level for measuring timing of signals.
Transition times are measured between V_{IH} (min) and V_{IL} (max).
 - *12. AC characteristics assume $t_r = 1$ ns and 30 pF of capacitive load.
- *Source : See MB811171822A Data Sheet for details on the electricals.

■ AC OPERATING TEST CONDITION (Example of AC Test Load Circuit)

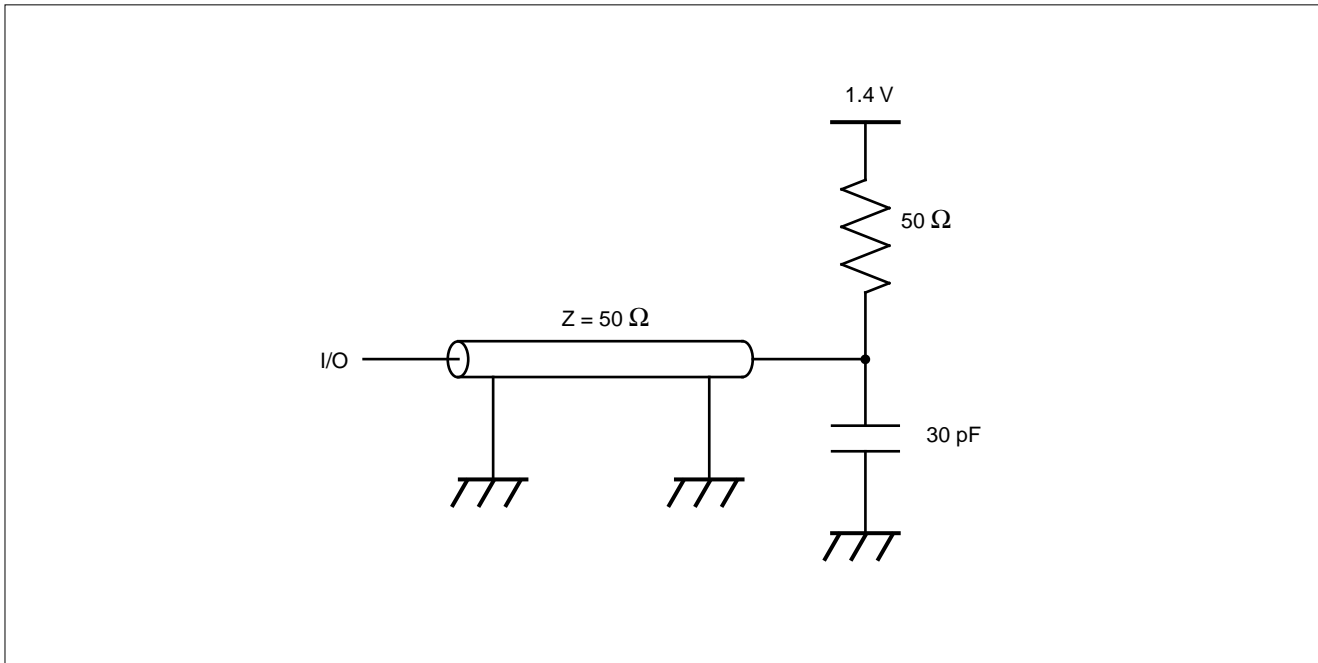

MB8502S064AD-100/-84/-67

■ SERIAL PRESENCE DETECT (SPD) FUNCTION

1. PIN DESCRIPTIONS

SCL (Serial Clock)

SCL input is used to clock all data input/output of SPD

SDA (Serial Data)

SDA is a common pin used for all data input/output of SPD. The SDA pull-up resistor is required due to the open-drain output.

SA₀, SA₁, SA₂ (Address)

Address inputs are used to set the least significant three bits of the eight bits slave address. The address inputs must be fixed to select a particular module and the fixed address of each module must be different each other. For this module, any address inputs are not required because all addresses (SA₀, SA₁, SA₂) are driven to V_{SS} on the module.

2. SPD OPERATIONS

CLOCK and DATA CONVENTION

Data states on the SDA can change only during SCL=Low. SDA state changes during SCL=High are indicated start and stop conditions. Refer to Fig.1 below.

START CONDITION

All commands are preceded by a start condition, which is a transition of SDA state from High to Low when SCL=High. SPD will not respond to any command until this condition has been met.

STOP CONDITION

All read or write operation must be terminated by a stop condition, which is a transition of SDA state from Low to High when SCL=High. The stop condition is also used to make the SPD into the state of standby power mode after a read sequence.

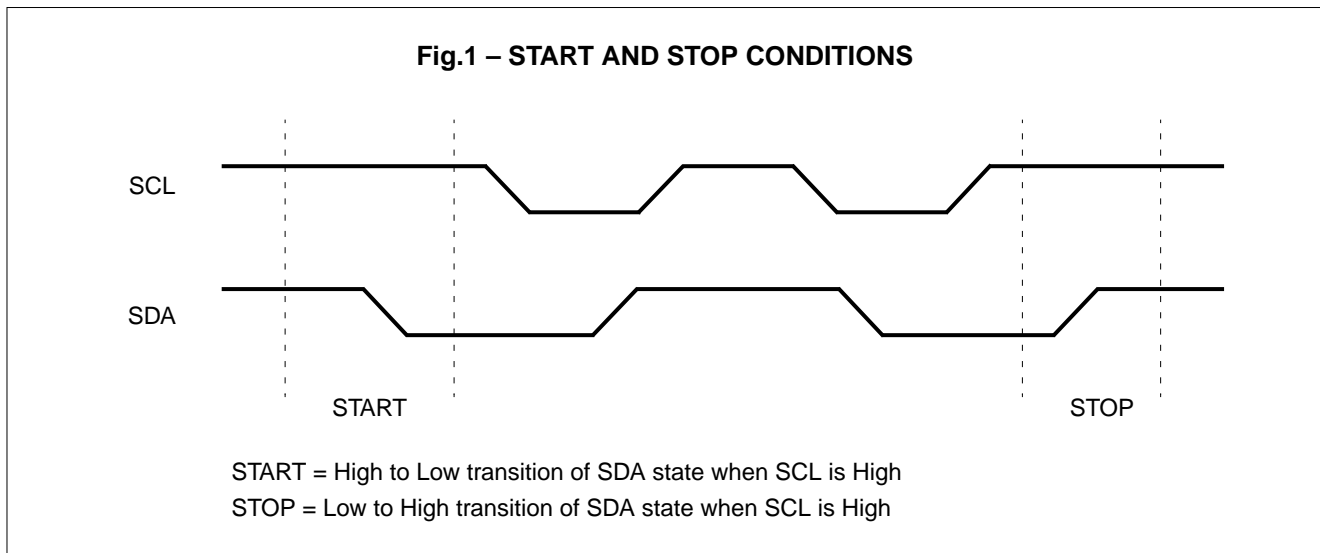

ACKNOWLEDGE

Acknowledge is a software convention used to indicate successful data transfer. The transmitting device, either master or slave, will release the bus after transmitting eight bits. During the ninth clock cycle the receiver will put the SDA line to Low in order to acknowledge that it received the eight bits of data.

The SPD will respond with an acknowledge when it received the start condition followed by slave address issued by master.

In the read operation, the SPD will transmit eight bits of data, release the SDA line and monitor the line for an acknowledge. If an acknowledge is detected and no stop condition is issued by master, the SPD will continue to transmit data. If an acknowledge is not detected, the SPD will terminated further data transmissions. The master must then issue a stop condition to return the SPD to the standby power mode.

In the write operation, upon receipt of eight bits of data the SPD will respond with an acknowledge, and await the next eight bits of data, again responding with an acknowledge until the stop condition is issued by master.

SLAVE ADDRESS ADDRESSING

Following a start condition, the master must output the eight bits slave address. The most significant four bits of the slave address are device type identifier. For the SPD this is fixed as 1010[B]. Refer to the Fig.2 below.

The next three significant bits are used to select a particular device. A system could have up to eight SPD devices—namely up to eight modules—on the bus. The eight addresses for eight SPD devices are defined by the state of the SA₀, SA₁ and SA₂ inputs. For this module, the three bits are fixed as 000[B] because all addresses are driven to V_{SS} on the module. Therefore, no address inputs are required.

The last bit of the slave address defines the operation to be performed. When R/ \bar{W} bit is “1”, a read operation is selected, when R/ \bar{W} bit is “0”, a write operation is selected.

Following the start condition, the SPD monitors the SDA line comparing the slave address being transmitted with its slave address (device type and state of SA₀, SA₁, and SA₂ inputs). Upon a correct compare the SPD outputs an acknowledge on the SDA line. Depending on the state of the R/ \bar{W} bit, the SPD will execute a read or write operation.

Fig.2 – SLAVE ADDRESS

| DEVICE TYPE IDENTIFIER | | | | DEVICE ADDRESS | | | |
|------------------------|---|---|---|-----------------|-----------------|-----------------|--------------|
| 1 | 0 | 1 | 0 | SA ₂ | SA ₁ | SA ₀ | R/ \bar{W} |

MB8502S064AD-100/-84/-67

3. READ OPERATIONS

CURRENT ADDRESS READ

Internally the SPD contains an address counter that maintains the address of the last data accessed, incremented by one. Therefore, if the last access (either a read or write operation) was to address(n), the next read operation would access data from address(n+1). Upon receipt of the slave address with the R/\bar{W} bit = "1", the SPD issues an acknowledge and transmits the eight bits of data during the next eight clock cycles. The master terminates this transmission by issuing a stop condition, omitting the ninth clock cycle acknowledge. Refer to Fig.3 for the sequence of address, acknowledge and data transfer.

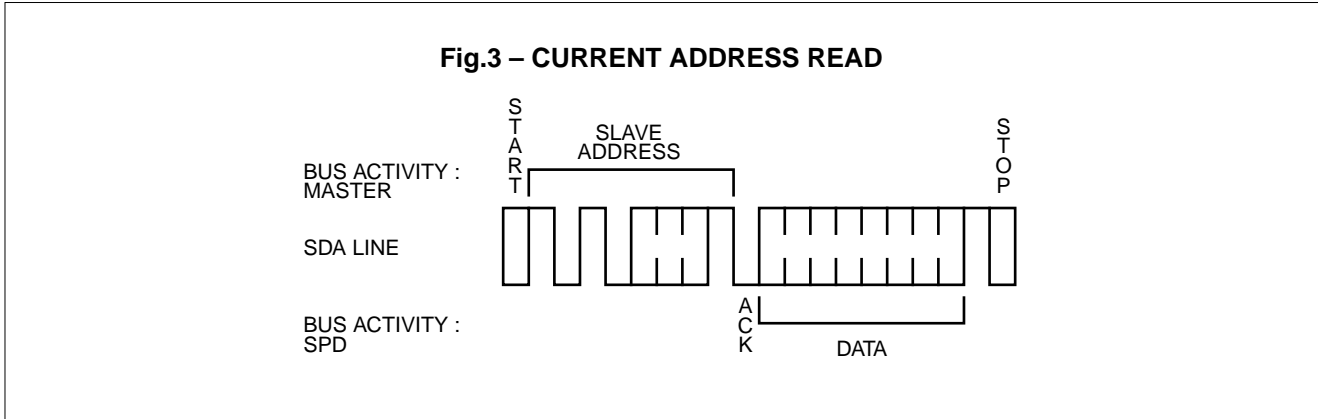

RANDOM READ

Random Read operations allow the master to access any memory location in a random manner. Prior to issuing the slave address with the R/\bar{W} bit = "1", the master must first perform a "dummy" write operation on the SPD. The master issues the start condition, and the slave address followed by the word address. After the word address acknowledge, the master immediately reissues the start condition and the slave address with the R/\bar{W} bit = "1". This will be followed by an acknowledge from the SPD and then by the eight bits of data. The master terminates this transmission by issuing a stop condition, omitting the ninth clock cycle acknowledge. Refer to Fig.4 for the sequence of address, acknowledge and data transfer.

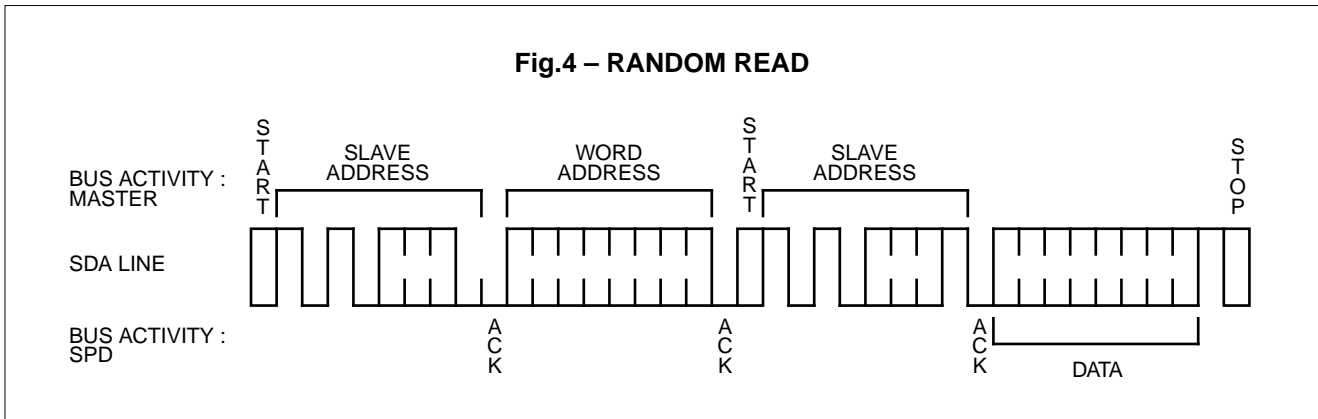

SEQUENTIAL READ

Sequential Read can be initiated as either a current address read or random read. The first data are transmitted as with the other read mode, however, the master now responds with an acknowledge, indicating it requires additional data. The SPD continues to output data for each acknowledge received. The master terminates this transmission by issuing a stop condition, omitting the ninth clock cycle acknowledge. Refer to Fig.5 for the sequence of address, acknowledge and data transfer.

The data output is sequential, with the data from address(n) followed by the data from address(n+1). The address counter for read operations increments all address bits, allowing the entire memory contents to be serially read during one operation. At the end of the address space (address 255), the counter “rolls over” to address 0 and the SPD continues to output data for each acknowledge received.

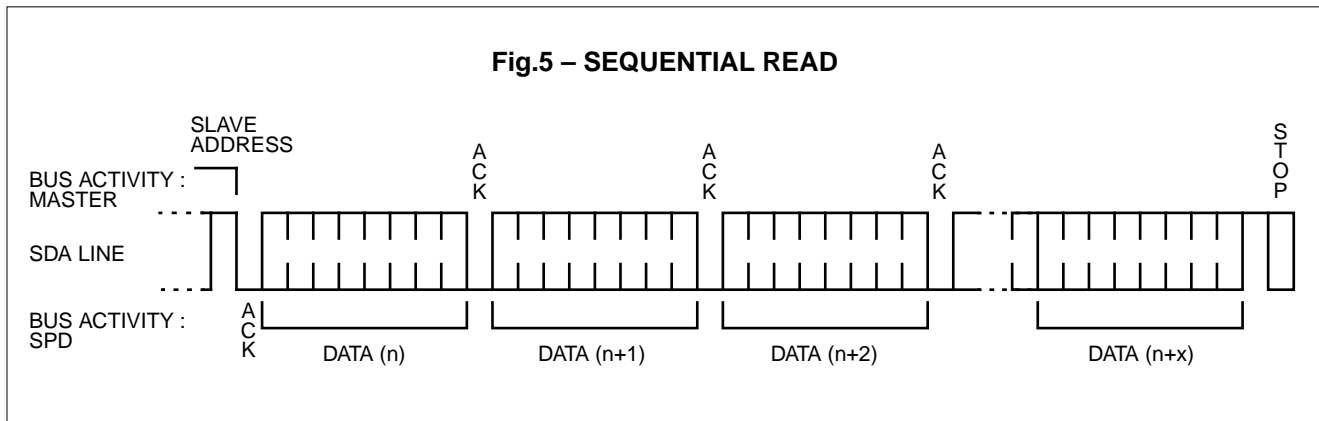

4. DC CHARACTERISTICS

| Parameter | Note | Symbol | Condition | Value | | Unit |
|------------------------|------|-----------|---------------------------------------|-------|------|---------------|
| | | | | Min. | Max. | |
| Input Leakage Current | | S_{ILI} | $0\text{ V} \leq V_{IN} \leq V_{CC}$ | -10 | 10 | μA |
| Output Leakage Current | | S_{ILO} | $0\text{ V} \leq V_{OUT} \leq V_{CC}$ | -10 | 10 | μA |
| Output Low Voltage | *1 | S_{VOL} | $I_{OL} = 3.0\text{ mA}$ | — | 0.4 | V |

Note: *1. Referenced to V_{SS} .

MB8502S064AD-100/-84/-67

5. AC CHARACTERISTICS

| No. | Parameter | Symbol | Min. | Max. | Unit |
|-----|---------------------------------------------------------------|--------------|------|------|---------|
| 1 | SCL Clock Frequency | f_{SCL} | 0 | 100 | KHz |
| 2 | Noise Suppression Time Constant at SCL, SDA Inputs | T_i | — | 100 | ns |
| 3 | SCL Low to SDA Data Out Valid | t_{AA} | — | 3.5 | μs |
| 4 | Time the Bus Must Be Free Before a New Transmission Can Start | t_{BUF} | 4.7 | — | μs |
| 5 | Start Condition Hold Time | $t_{HD:STA}$ | 4.0 | — | μs |
| 6 | Clock Low Period | t_{LOW} | 4.7 | — | μs |
| 7 | Clock High Period | t_{HIGH} | 4.0 | — | μs |
| 8 | Start Condition Set Up Time | $t_{SU:STA}$ | 4.7 | — | μs |
| 9 | Data In Hold Time | $t_{HD:DAT}$ | 0 | — | μs |
| 10 | Data In Set Up Time | $t_{SU:DAT}$ | 250 | — | ns |
| 11 | SDA and SCL Rise Time | t_R | — | 1 | μs |
| 12 | SDA and SCL Fall Time | t_F | — | 300 | ns |
| 13 | Stop Condition Set Up Time | $t_{SU:STO}$ | 4.7 | — | μs |
| 14 | Data Out Hold Time | t_{DH} | 100 | — | ns |
| 15 | Write Cycle Time | t_{WR} | — | 15 | ms |

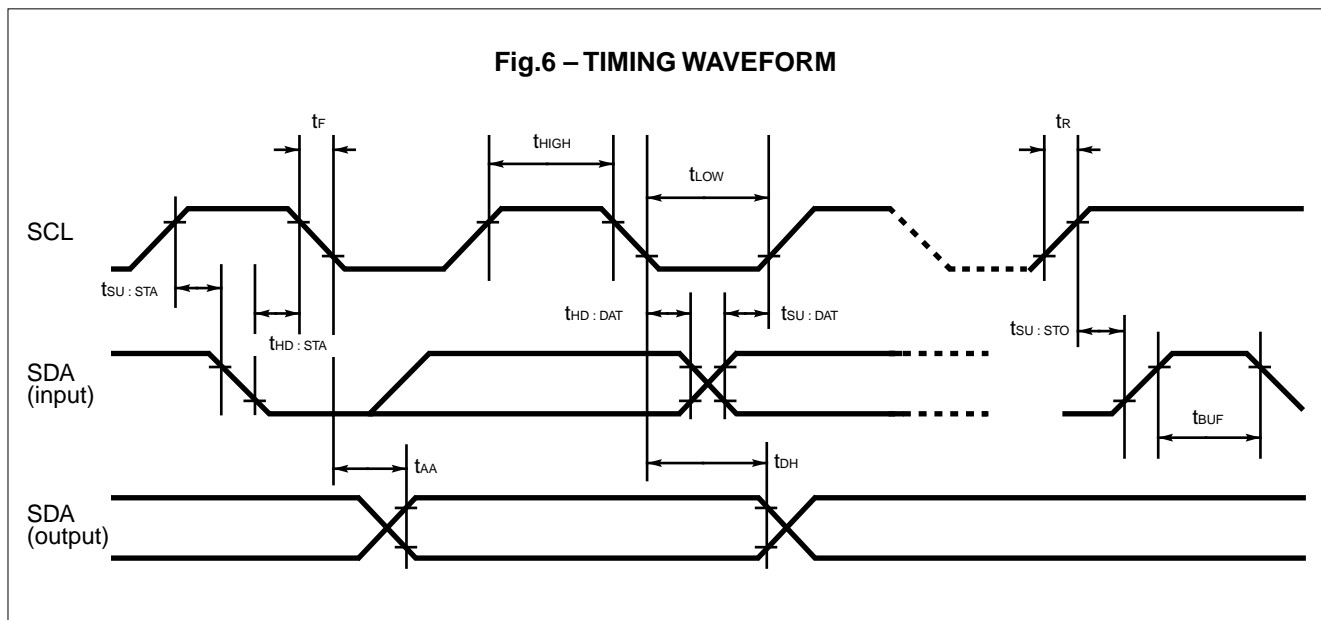

MB8502S064AD-100/-84/-67

■ PACKAGE DIMENSIONS

144-PIN SMALL OUTLINE DUAL IN-LINE MEMORY MODULE (CASE No.: MDS-144P-P04)

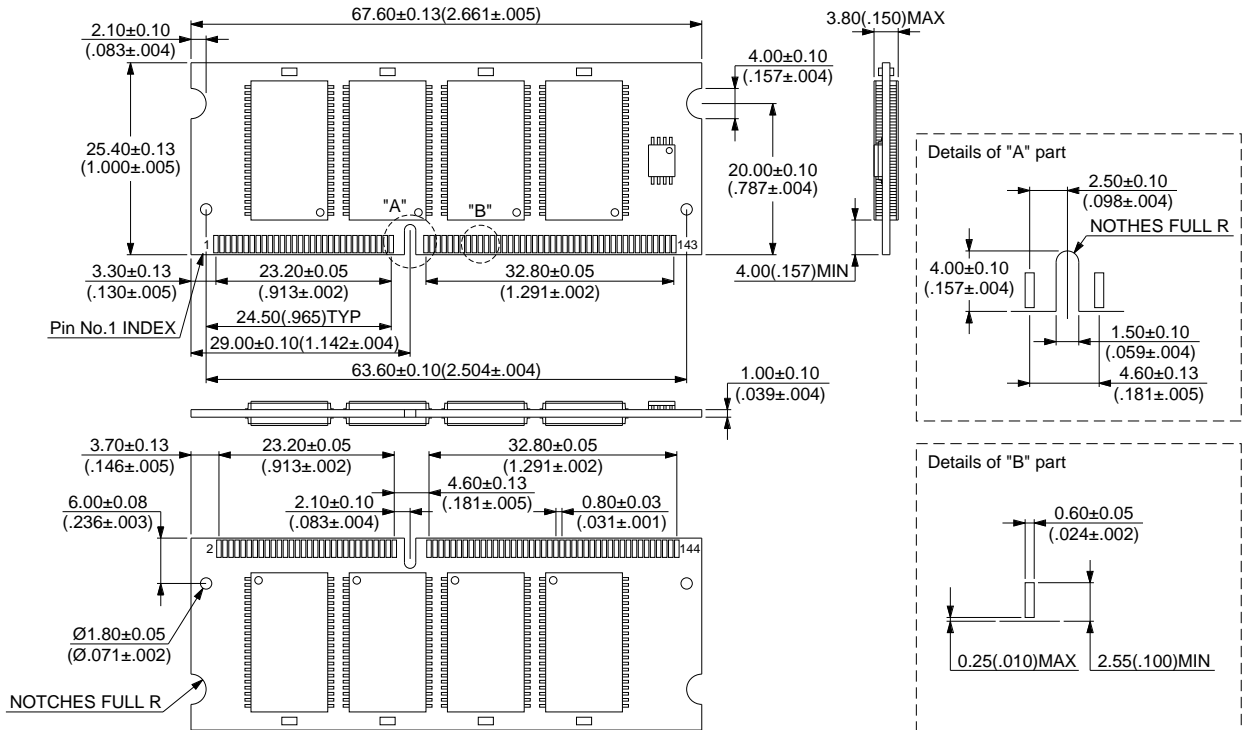

© 1996 FUJITSU LIMITED M144004SC-2-2

Dimension in mm (inches).

FUJITSU LIMITED

For further information please contact:

Japan

FUJITSU LIMITED
Corporate Global Business Support Division
Electronic Devices
KAWASAKI PLANT, 4-1-1, Kamikodanaka
Nakahara-ku, Kawasaki-shi
Kanagawa 211-88, Japan
Tel: (044) 754-3763
Fax: (044) 754-3329

North and South America

FUJITSU MICROELECTRONICS, INC.
Semiconductor Division
3545 North First Street
San Jose, CA 95134-1804, U.S.A.
Tel: (408) 922-9000
Fax: (408) 432-9044/9045

Europe

FUJITSU MIKROELEKTRONIK GmbH
Am Siebenstein 6-10
63303 Dreieich-Buchschlag
Germany
Tel: (06103) 690-0
Fax: (06103) 690-122

Asia Pacific

FUJITSU MICROELECTRONICS ASIA PTE. LIMITED
#05-08, 151 Lorong Chuan
New Tech Park
Singapore 556741
Tel: (65) 281-0770
Fax: (65) 281-0220

All Rights Reserved.

The contents of this document are subject to change without notice. Customers are advised to consult with FUJITSU sales representatives before ordering.

The information and circuit diagrams in this document presented as examples of semiconductor device applications, and are not intended to be incorporated in devices for actual use. Also, FUJITSU is unable to assume responsibility for infringement of any patent rights or other rights of third parties arising from the use of this information or circuit diagrams.

FUJITSU semiconductor devices are intended for use in standard applications (computers, office automation and other office equipment, industrial, communications, and measurement equipment, personal or household devices, etc.).

CAUTION:

Customers considering the use of our products in special applications where failure or abnormal operation may directly affect human lives or cause physical injury or property damage, or where extremely high levels of reliability are demanded (such as aerospace systems, atomic energy controls, sea floor repeaters, vehicle operating controls, medical devices for life support, etc.) are requested to consult with FUJITSU sales representatives before such use. The company will not be responsible for damages arising from such use without prior approval.

Any semiconductor devices have inherently a certain rate of failure. You must protect against injury, damage or loss from such failures by incorporating safety design measures into your facility and equipment such as redundancy, fire protection, and prevention of over-current levels and other abnormal operating conditions.

If any products described in this document represent goods or technologies subject to certain restrictions on export under the Foreign Exchange and Foreign Trade Control Law of Japan, the prior authorization by Japanese government should be required for export of those products from Japan.