

1,024/2,048/4,096-BIT SERIAL ELECTRICALLY ERASABLE PROM

NOVEMBER 2002

FEATURES

- Industry-standard Microwire Interface
 - Non-volatile data storage
 - Low voltage operation:
 - V_{cc} = 2.5V to 5.5V
 - Full TTL compatible inputs and outputs
 - Auto increment for efficient data dump
- User Configured Memory Organization
 - By 16-bit or by 8-bit
- Hardware and software write protection
 - Defaults to write-disabled state at power-up
 - Software instructions for write-enable/disable
- Enhanced low voltage CMOS E²PROM technology
- Versatile, easy-to-use Interface
 - Self-timed programming cycle
 - Automatic erase-before-write
 - Programming status indicator
 - Word and chip erasable
 - Stop SK anytime for power savings
- Durable and reliable
 - 40-year data retention after 1M write cycles
 - 1 million write cycles
 - Unlimited read cycles
 - Schmitt-trigger inputs
- Industrial and Automotive Temperature Grade

DESCRIPTION

The IS93C46A/56A/66A is a low-cost 1kb/2kb/4kb non-volatile, ISSI[®] serial EEPROM. It is fabricated using an enhanced CMOS design and process. The IS93C46A/56A/66A contain power-efficient read/write memory, and organization of either 128/256/512 bytes of 8 bits or 64/128/256 words of 16 bits. When the ORG pin is connected to V_{cc} or left unconnected, x16 is selected; when it is connected to ground, x8 is selected. The IS93C46A/56A/66A is fully backwards compatible with IS93C46/56/66.

An instruction set controls the operation of the devices, including read, write, and mode-enable functions. The data out pin (Dout) indicates the status of the device during the self-timed non-volatile programming cycle. The self-timed write cycle includes an automatic erase-before-write capability. To protect against inadvertent writes, the WRITE instruction is accepted only while the chip is in the write-enabled state. Data is written once per WRITE instruction to the x8 byte or x16 word selected. If Chip Select (CS) is brought HIGH just after initiation of the write cycle, the Dout pin would indicate the Ready/Busy status of the write activity.

FUNCTIONAL BLOCK DIAGRAM

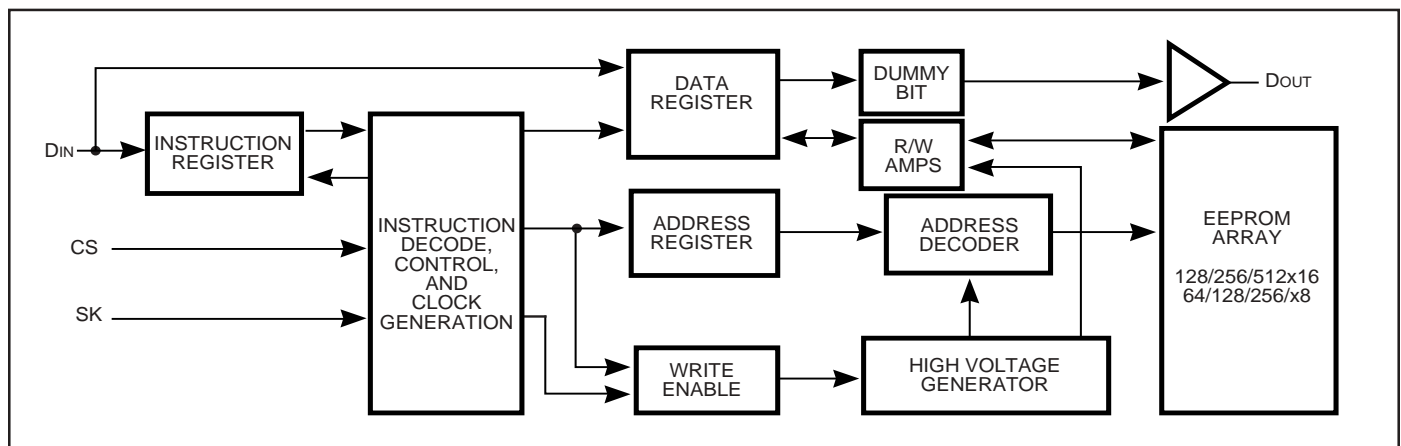

Copyright © 2002 Integrated Silicon Solution, Inc. All rights reserved. ISSI reserves the right to make changes to this specification and its products at any time without notice. ISSI assumes no liability arising out of the application or use of any information, products or services described herein. Customers are advised to obtain the latest version of this device specification before relying on any published information and before placing orders for products.

PIN CONFIGURATIONS

8-Pin DIP, 8-Pin TSSOP

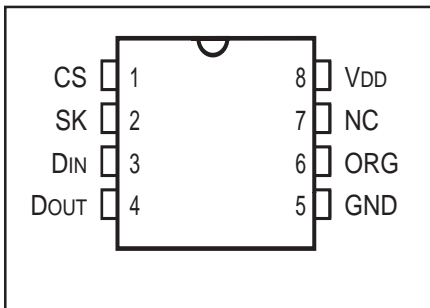

8-Pin JEDEC SOIC "G"

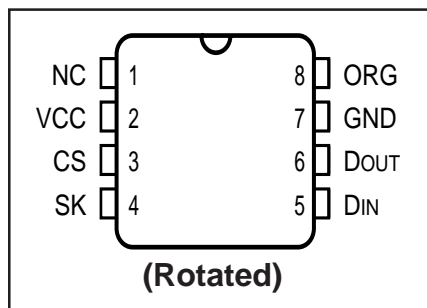

8-Pin JEDEC SOIC "GR"

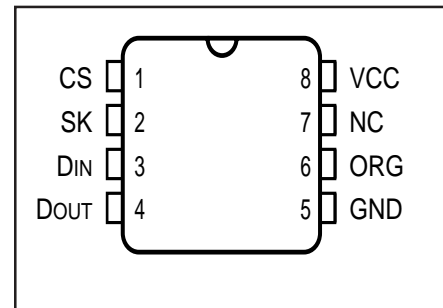

PIN DESCRIPTIONS

CS	Chip Select
SK	Serial Data Clock
DIN	Serial Data Input
DOUT	Serial Data Output
ORG	Organization Select
NC	Not Connected
Vcc	Power
GND	Ground

Applications

The IS93C46A/56A/66A is very popular in many high-volume applications which require low-power, low-density storage. Applications using this device include industrial controls, networking, and numerous other consumer electronics.

Endurance and Data Retention

The IS93C46A/56A/66A is designed for applications requiring up to 1M programming cycles (WRITE, WRALL, ERASE and ERAL). It provides 40 years of secure data retention without power after the execution of 1M programming cycles.

Device Operations

The IS93C46A/56A/66A are controlled by a set of instructions which are clocked-in serially on the Din pin. Before each low-to-high transition of the clock (SK), the CS pin must have already been raised to HIGH, and the Din value must be stable at either LOW or HIGH. Each

instruction begins with a start bit of the logical "1" or HIGH. Following this are the opcode (2 bits), address field (6, 7, 8, or 9 bits), and data, if appropriate. The clock signal may be held stable at any moment to suspend the device at its last state. This allows clock-speed flexibility as well as maximum power conservation.

Read (READ)

The READ instruction is the only instruction that outputs serial data on the DOUT pin. After the read instruction and address have been decoded, data is transferred from the selected memory register into a serial shift register. (Please note that one logical "0" bit precedes the actual 8 or 16-bit output data string.) The output on DOUT changes during the low-to-high transitions of SK (see Figure 3).

Low Voltage Read

The IS93C46A/56A/66A have been designed to ensure that data read operations are reliable in low voltage environments. They provide accurate operation with Vcc as low as 2.5V.

Auto Increment Read Operations

In the interest of memory transfer operation applications, the IS93C46A/56A/66A has been designed to output a continuous stream of memory content in response to a single read operation instruction. To utilize this function, the system asserts a read instruction specifying a start location address. Once the 8 or 16 bits of the addressed register have been clocked out, the data in consecutively higher address locations is output. The address will wrap around continuously with CS HIGH until the chip select (CS) control pin is brought LOW. This allows for single instruction data dumps to be executed with a minimum of firmware overhead.

Write Enable (WEN)

The write enable (WEN) instruction must be executed before any device programming (WRITE, WRALL, ERASE, and ERAL) can be done. When Vcc is applied, this device powers up in the write disabled state. The device then remains in a write disabled state until a WEN instruction is executed. Thereafter, the device remains enabled until a WDS instruction is executed or until Vcc is removed. (See Figure 4.) (Note: Chip select must remain LOW until Vcc reaches its operational value.)

Write (WRITE)

The WRITE instruction includes 8 or 16 bits of data to be written into the specified register. After the last data bit has been applied to D_{IN}, and before the next rising edge of SK, CS must be brought LOW. The falling edge of CS initiates the self-timed programming cycle.

If CS is brought HIGH, after a minimum wait of 250 ns (5V operation) after the falling edge of CS (t_{CS}) D_{OUT} will indicate the READY/BUSY status of the chip. Logical “0” means programming is still in progress, logical “1” means the selected register has been written, and the part is ready for another instruction (see Figure 5). (NOTE: The combination of CS HIGH, D_{IN} HIGH and the rising edge of the SK clock, resets the READY/BUSY flag. Therefore, to access the READY/BUSY flag, this combination of control signals should be avoided.) Before a WRITE instruction can be executed, the device must be write enabled (see WEN).

Write All (WRALL)

The write all (WRALL) instruction programs all registers with the data pattern specified in the instruction. As with the WRITE instruction, the falling edge of CS must occur to initiate the self-timed programming cycle. If CS is then brought HIGH after a minimum wait of 250 ns (t_{CS}), the D_{OUT} pin indicates the READY/BUSY status of the chip (see Figure 6).

Write Disable (WDS)

The write disable (WDS) instruction disables all programming capabilities. This protects the entire device against accidental modification of data until a WEN instruction is executed. (When Vcc is applied, this part powers up in the write disabled state.) To protect data, a WDS instruction should be executed upon completion of each programming operation.

Erase Register (ERASE)

After the erase instruction is entered, CS must be brought LOW. The falling edge of CS initiates the self-timed internal programming cycle. Bringing CS HIGH after a minimum of t_{CS}, will cause D_{OUT} to indicate the READ/BUSY status of the chip: a logical “0” indicates programming is still in progress; a logical “1” indicates the erase cycle is complete and the part is ready for another instruction (see Figure 8).

Erase All (ERAL)

Full chip erase is provided for ease of programming. Erasing the entire chip involves setting all bits in the entire memory array to a logical “1” (see Figure 9).

INSTRUCTION SET - IS93C46A

Instruction	Start Bit	OP Code	8-bit Organization		16-bit Organization	
			Address ⁽¹⁾	Input Data	Address ⁽¹⁾	Input Data
READ	1	10	(A6-A0)	—	(A5-A0)	—
WEN (Write Enable)	1	00	11xxxx	—	11xxxx	—
WRITE	1	01	(A6-A0)	(D7-D0) ⁽³⁾	(A5-A0)	(D15-D0) ⁽²⁾
WRALL (Write All Registers)	1	00	01xxxx	(D7-D0) ⁽³⁾	01xxxx	(D15-D0) ⁽²⁾
WDS (Write Disable)	1	00	00xxxx	—	00xxxx	—
ERASE	1	11	(A6-A0)	—	(A5-A0)	—
ERAL (Erase All Registers)	1	00	10xxxx	—	10xxxx	—

Notes:

1. x = Don't care bit.
2. If input data is not 16 bits exactly, the last 16 bits will be taken as input data.
3. If input data is not 8 bits exactly, the last 8 bits will be taken as input data.

INSTRUCTION SET - IS93C56A

Instruction	Start Bit	OP Code	8-bit Organization		16-bit Organization	
			(ORG = GND)		(ORG = Vcc)	
			Address ⁽¹⁾	Input Data	Address ⁽¹⁾	Input Data
READ	1	10	x(A7-A0)	—	x(A6-A0)	—
WEN (Write Enable)	1	00	11xxxxxxx	—	11xxxxxx	—
WRITE	1	01	x(A7-A0)	(D7-D0) ⁽³⁾	x(A6-A0)	(D15-D0) ⁽²⁾
WRALL (Write All Registers)	1	00	01xxxxxxx	(D7-D0) ⁽³⁾	01xxxxxx	(D15-D0) ⁽²⁾
WDS (Write Disable)	1	00	00xxxxxxx	—	00xxxxxx	—
ERASE	1	11	x(A7-A0)	—	x(A6-A0)	—
ERAL (Erase All Registers)	1	00	10xxxxxxx	—	10xxxxxx	—

Notes:

1. x = Don't care bit.
2. If input data is not 16 bits exactly, the last 16 bits will be taken as input data.
3. If input data is not 8 bits exactly, the last 8 bits will be taken as input data.

INSTRUCTION SET - IS93C66A

Instruction	Start Bit	OP Code	8-bit Organization		16-bit Organization	
			(ORG = GND)		(ORG = Vcc)	
			Address ⁽¹⁾	Input Data	Address ⁽¹⁾	Input Data
READ	1	10	(A8-A0)	—	(A7-A0)	—
WEN (Write Enable)	1	00	11xxxxxxx	—	11xxxxxx	—
WRITE	1	01	(A8-A0)	(D7-D0) ⁽³⁾	(A7-A0)	(D15-D0) ⁽²⁾
WRALL (Write All Registers)	1	00	01xxxxxxx	(D7-D0) ⁽³⁾	01xxxxxx	(D15-D0) ⁽²⁾
WDS (Write Disable)	1	00	00xxxxxxx	—	00xxxxxx	—
ERASE	1	11	(A8-A0)	—	(A7-A0)	—
ERAL (Erase All Registers)	1	00	10xxxxxxx	—	10xxxxxx	—

Notes:

1. x = Don't care bit.
2. If input data is not 16 bits exactly, the last 16 bits will be taken as input data.
3. If input data is not 8 bits exactly, the last 8 bits will be taken as input data.

ABSOLUTE MAXIMUM RATINGS⁽¹⁾

Symbol	Parameter	Value	Unit
V _{GND}	Voltage with Respect to GND	-0.3 to +6.5	V
T _{BIAS}	Temperature Under Bias (Industrial)	-40 to +85	°C
T _{BIAS}	Temperature Under Bias (Automotive)	-40 to +125	°C
T _{STG}	Storage Temperature	-65 to +150	°C

Notes:

1. Stress greater than those listed under ABSOLUTE MAXIMUM RATINGS may cause permanent damage to the device. This is a stress rating only and functional operation of the device at these or any other conditions above those indicated in the operational sections of this specification is not implied. Exposure to absolute maximum rating conditions for extended periods may affect reliability.

OPERATING RANGE

Range	Ambient Temperature	V _{cc}
Industrial	-40°C to +85°C	2.5V to 5.5V
Automotive	-40°C to +125°C	2.7V to 5.5V or 4.5V to 5.5V

CAPACITANCE

Symbol	Parameter	Conditions	Max.	Unit
C _{IN}	Input Capacitance	V _{IN} = 0V	5	pF
C _{OUT}	Output Capacitance	V _{OUT} = 0V	5	pF

DC ELECTRICAL CHARACTERISTICS

T_A = -40°C to +85°C for Industrial and -40°C to +125°C for Automotive.

Symbol	Parameter	Test Conditions	V _{cc}	Min.	Max.	Unit
V _{OL}	Output LOW Voltage	I _{OL} = 100 μA	2.5V to 5.5V	—	0.2	V
V _{OL1}	Output LOW Voltage	I _{OL} = 2.1 mA	4.5V to 5.5V	—	0.4	V
V _{OH}	Output HIGH Voltage	I _{OH} = -100 μA	2.5V to 5.5V	V _{cc} - 0.2	—	V
V _{OH1}	Output HIGH Voltage	I _{OH} = -400 μA	4.5V to 5.5V	2.4	—	V
V _{IH}	Input HIGH Voltage		2.5V to 5.5V 4.5V to 5.5V	0.7xV _{cc} 0.7xV _{cc}	V _{cc} +1 V _{cc} +1	V
V _{IL}	Input LOW Voltage		2.5V to 5.5V 4.5V to 5.5V	-0.3 -0.3	0.2xV _{cc} 0.8	V
I _{LI}	Input Leakage	V _{IN} = 0V to V _{cc} (CS, SK, DIN, ORG)		0	2.5	μA
I _{LO}	Output Leakage	V _{OUT} = 0V to V _{cc} , CS = 0V		0	2.5	μA

Notes:

Automotive grade devices in this table are tested with V_{cc} = 2.7V to 5.5V and 4.5V to 5.5V.

POWER SUPPLY CHARACTERISTICS

T_A = -40°C to +85°C for Industrial

Symbol	Parameter	Test Conditions	V _{cc}	Min.	Typ.	Max.	Unit
I _{cc1}	V _{cc} Read Supply Current	CS = V _{IH} , SK = 1 MHz CMOS input levels	2.7V 5.0V	— —	40 100	100 500	μA μA
I _{cc2}	V _{cc} Write Supply Current	CS = V _{IH} , SK = 1 MHz CMOS input levels	2.7V 5.0V	— —	0.4 1.5	1 3	mA mA
I _{SB}	Standby Current	CS = V _{IH} , SK = 0V	2.7V 5.0V	— —	0.4 2	2 4	μA μA

POWER SUPPLY CHARACTERISTICS

T_A = -40°C to +125°C for Automotive

Symbol	Parameter	Test Conditions	V _{cc}	Min.	Typ.	Max.	Unit
I _{cc1}	V _{cc} Read Supply Current	CS = V _{IH} , SK = 1 MHz CMOS input levels	2.7V 5.0V	— —	40 100	100 500	μA μA
I _{cc2}	V _{cc} Write Supply Current	CS = V _{IH} , SK = 1 MHz CMOS input levels	2.7V 5.0V	— —	0.4 1.5	1 3	mA mA
I _{SB}	Standby Current	CS = V _{IH} , SK = 0V	2.7V 5.0V	— —	0.5 4	3 8	μA μA

AC ELECTRICAL CHARACTERISTICS

TA = -40°C to +125°C for Automotive

Symbol	Parameter	Test Conditions	Vcc	Min.	Max.	Unit
f _{SK}	SK Clock Frequency		2.7V to 5.5V	0	1	Mhz
			4.5V to 5.5V	0	2	Mhz
t _{SKH}	SK HIGH Time		2.7V to 5.5V	500	—	ns
			4.5V to 5.5V	250	—	ns
t _{SKL}	SK LOW Time		2.7V to 5.5V	500	—	ns
			4.5V to 5.5V	250	—	ns
t _{CS}	Minimum CS LOW Time		2.7V to 5.5V	250	—	ns
			4.5V to 5.5V	250	—	ns
t _{CSS}	CS Setup Time	Relative to SK	2.7V to 5.5V	100	—	ns
			4.5V to 5.5V	50	—	ns
t _{DIS}	Din Setup Time	Relative to SK	2.7V to 5.5V	100	—	ns
			4.5V to 5.5V	100	—	ns
t _{CSH}	CS Hold Time	Relative to SK	2.7V to 5.5V	0	—	ns
			4.5V to 5.5V	0	—	ns
t _{DIH}	Din Hold Time	Relative to SK	2.7V to 5.5V	100	—	ns
			4.5V to 5.5V	100	—	ns
t _{PD1}	Output Delay to "1"	AC Test	2.7V to 5.5V	—	400	ns
			4.5V to 5.5V	—	250	ns
t _{PD0}	Output Delay to "0"	AC Test	2.7V to 5.5V	—	400	ns
			4.5V to 5.5V	—	250	ns
t _{SV}	CS to Status Valid	AC Test	2.7V to 5.5V	—	250	ns
			4.5V to 5.5V	—	250	ns
t _{DF}	CS to Dout in 3-state	AC Test, CS=VIL	2.7V to 5.5V	—	200	ns
			4.5V to 5.5V	—	100	ns
t _{WP}	Write Cycle Time		2.7V to 5.5V	—	10	ms
			4.5V to 5.5V	—	5	ms

Notes:1. C_L = 100pF

AC ELECTRICAL CHARACTERISTICS

TA = -40°C to +85°C for Industrial

Symbol	Parameter	Test Conditions	Vcc	Min.	Max.	Unit
f _{SK}	SK Clock Frequency		2.5V to 5.5V	0	1	Mhz
			2.7V to 5.5V	0	1	Mhz
			4.5V to 5.5V	0	2	Mhz
t _{SKH}	SK HIGH Time		2.5V to 5.5V	500	—	ns
			2.7V to 5.5V	350	—	ns
			4.5V to 5.5V	250	—	ns
t _{SKL}	SK LOW Time		2.5V to 5.5V	500	—	ns
			2.7V to 5.5V	350	—	ns
			4.5V to 5.5V	250	—	ns
t _{CS}	Minimum CS LOW Time		2.5V to 5.5V	500	—	ns
			2.7V to 5.5V	250	—	ns
			4.5V to 5.5V	250	—	ns
t _{CSS}	CS Setup Time	Relative to SK	2.5V to 5.5V	100	—	ns
			2.7V to 5.5V	50	—	ns
			4.5V to 5.5V	50	—	ns
t _{DIS}	Din Setup Time	Relative to SK	2.5V to 5.5V	100	—	ns
			2.7V to 5.5V	100	—	ns
			4.5V to 5.5V	100	—	ns
t _{CSH}	CS Hold Time	Relative to SK	2.5V to 5.5V	0	—	ns
			2.7V to 5.5V	0	—	ns
			4.5V to 5.5V	0	—	ns
t _{DIH}	Din Hold Time	Relative to SK	2.5V to 5.5V	100	—	ns
			2.7V to 5.5V	100	—	ns
			4.5V to 5.5V	100	—	ns
t _{PD1}	Output Delay to "1"	AC Test	2.5V to 5.5V	—	400	ns
			2.7V to 5.5V	—	350	ns
			4.5V to 5.5V	—	250	ns
t _{PD0}	Output Delay to "0"	AC Test	2.5V to 5.5V	—	400	ns
			2.7V to 5.5V	—	350	ns
			4.5V to 5.5V	—	250	ns
t _{SV}	CS to Status Valid	AC Test	2.5V to 5.5V	—	400	ns
			2.7V to 5.5V	—	250	ns
			4.5V to 5.5V	—	250	ns
t _{DF}	CS to Dout in 3-state	AC Test, CS=VIL	2.5V to 5.5V	—	200	ns
			2.7V to 5.5V	—	200	ns
			4.5V to 5.5V	—	100	ns
t _{WP}	Write Cycle Time		2.5V to 5.5V	—	10	ms
			2.7V to 5.5V	—	10	ms
			4.5V to 5.5V	—	5	ms

Notes:

1. C_L = 100pF

AC WAVEFORMS

FIGURE 2. SYNCHRONOUS DATA TIMING

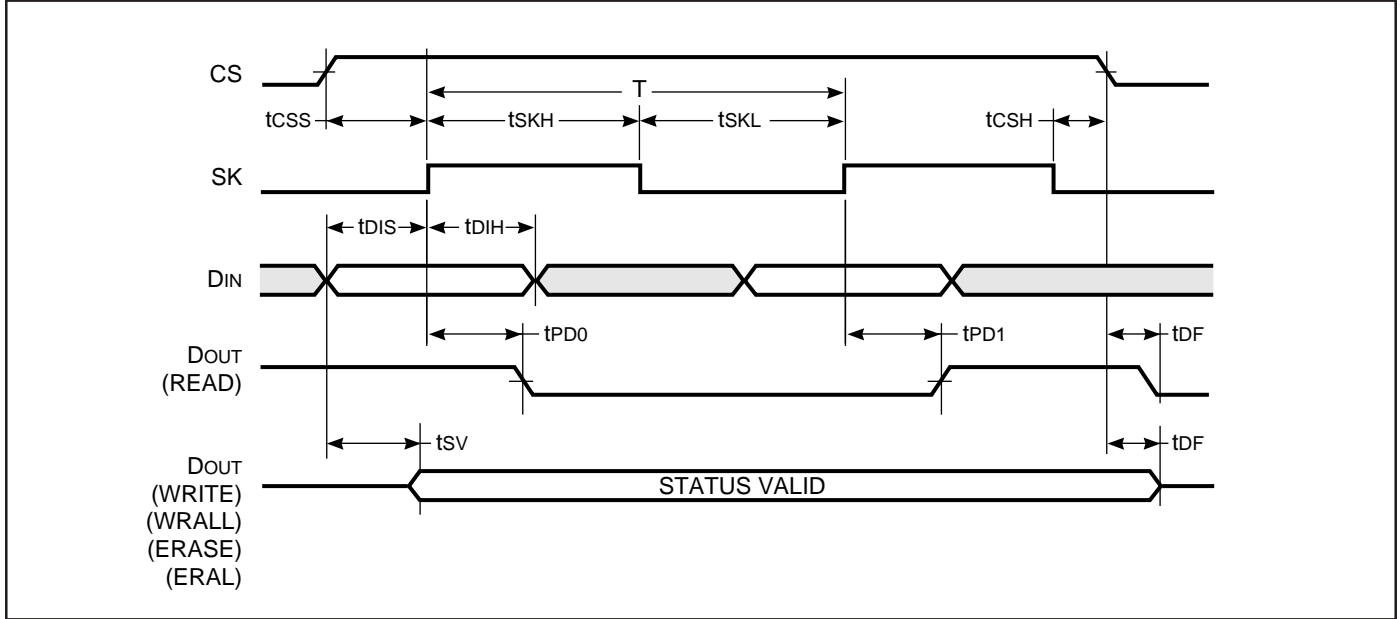
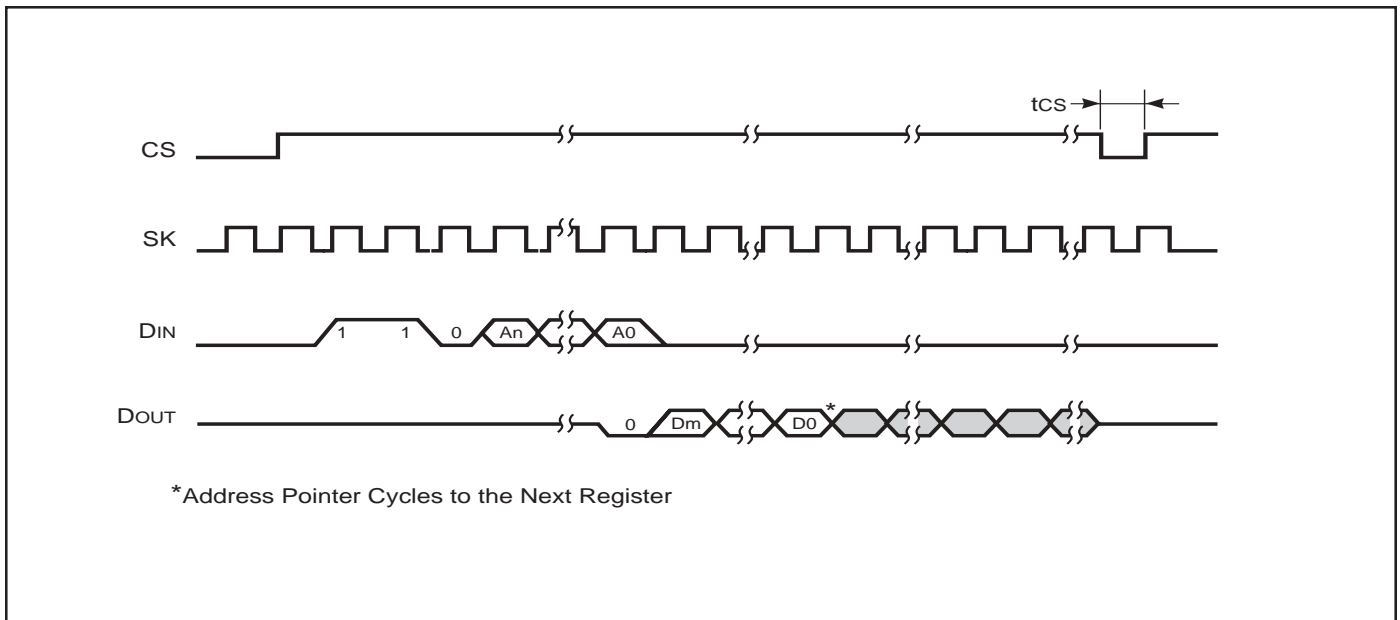

FIGURE 3. READ CYCLE TIMING



Notes:

To determine address bits A_n - A_0 and data bits D_m - D_0 , see Instruction Set for the specific device.

AC WAVEFORMS

FIGURE 4. SYNCHRONOUS DATA TIMING

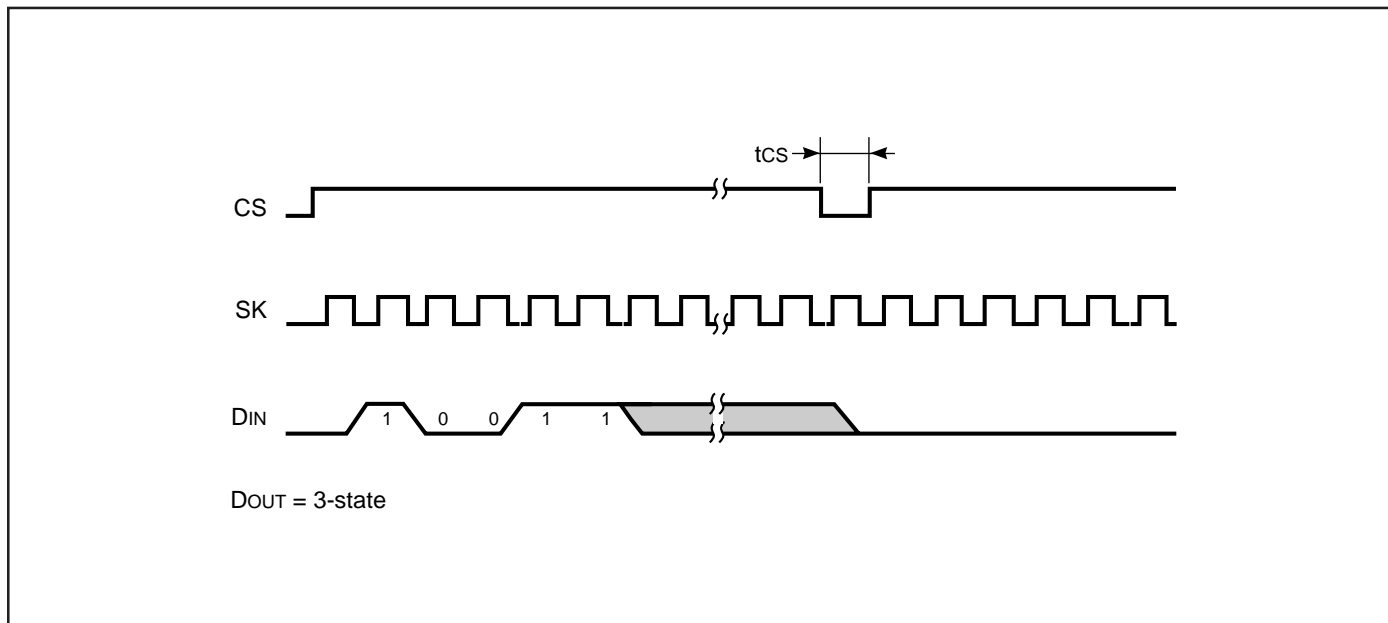
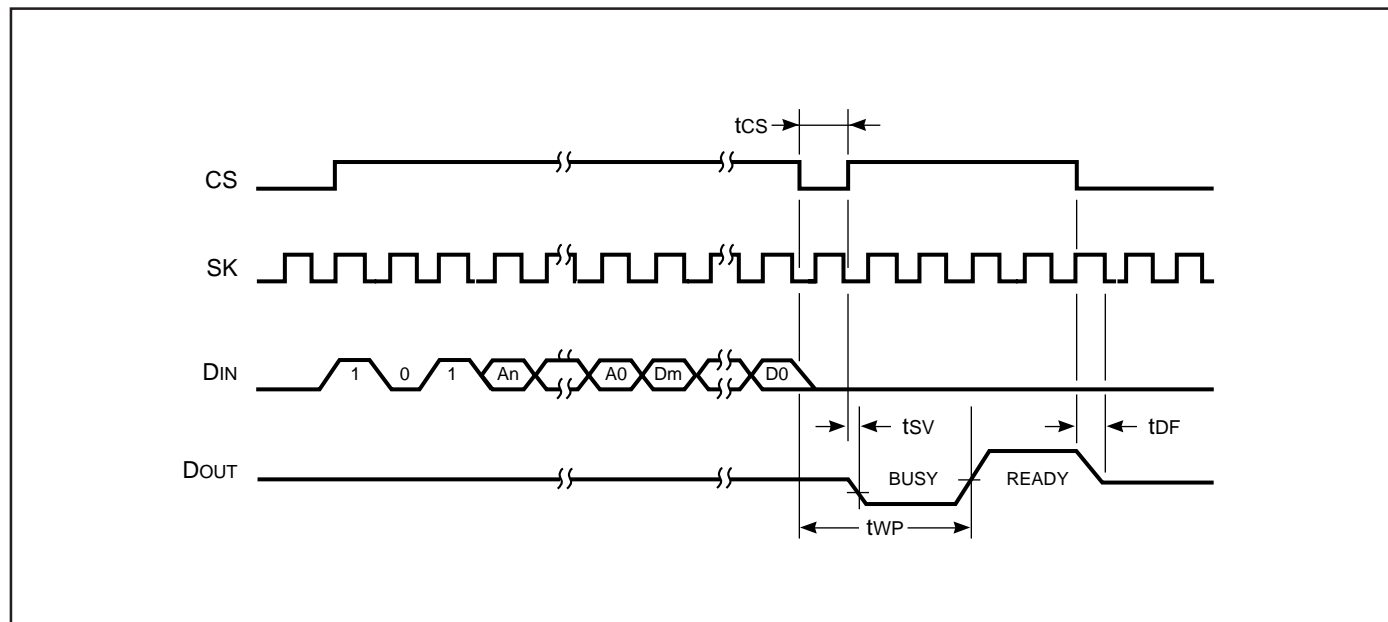

FIGURE 5. WRITE (WRITE) CYCLE TIMING

**Notes:**

To determine address bits A_n - A_0 and data bits D_m - D_0 , see Instruction Set for the specific device.

AC WAVEFORMS

FIGURE 6. WRITE ALL (WRALL) TIMING

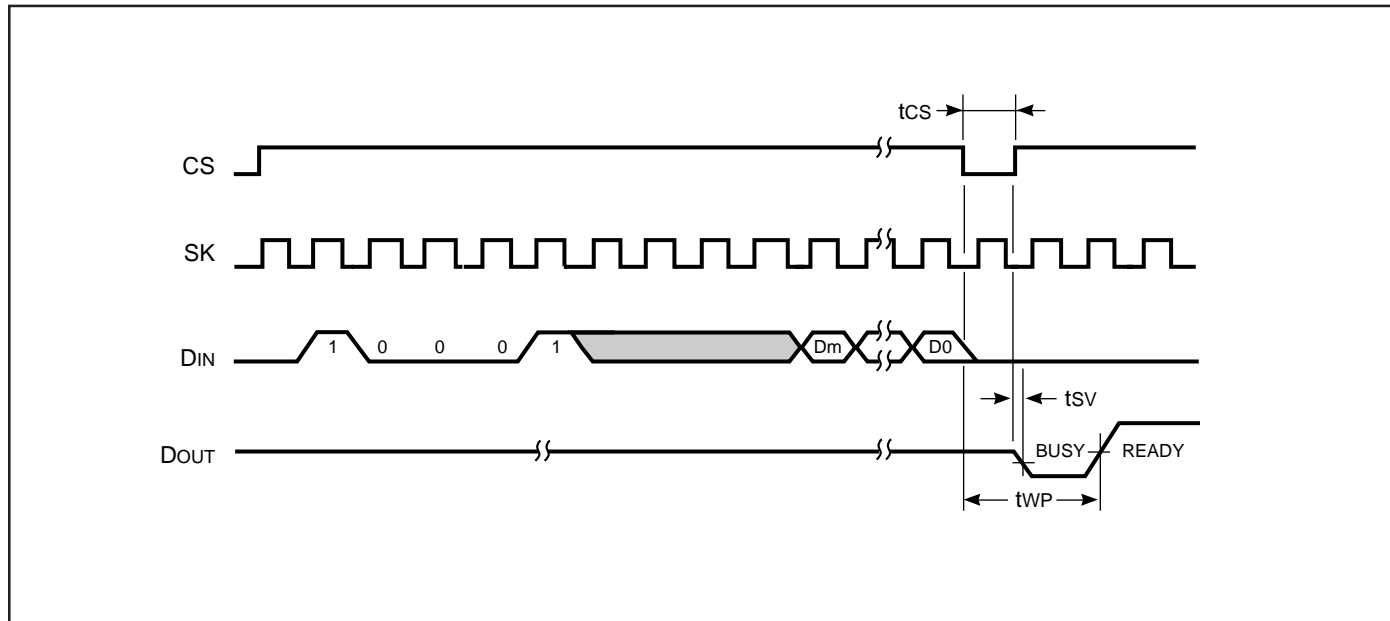

Notes:

To determine data bits D_m - D_0 , see Instruction Set for the appropriate device.

FIGURE 7. WRITE DISABLE (WDS) CYCLE TIMING

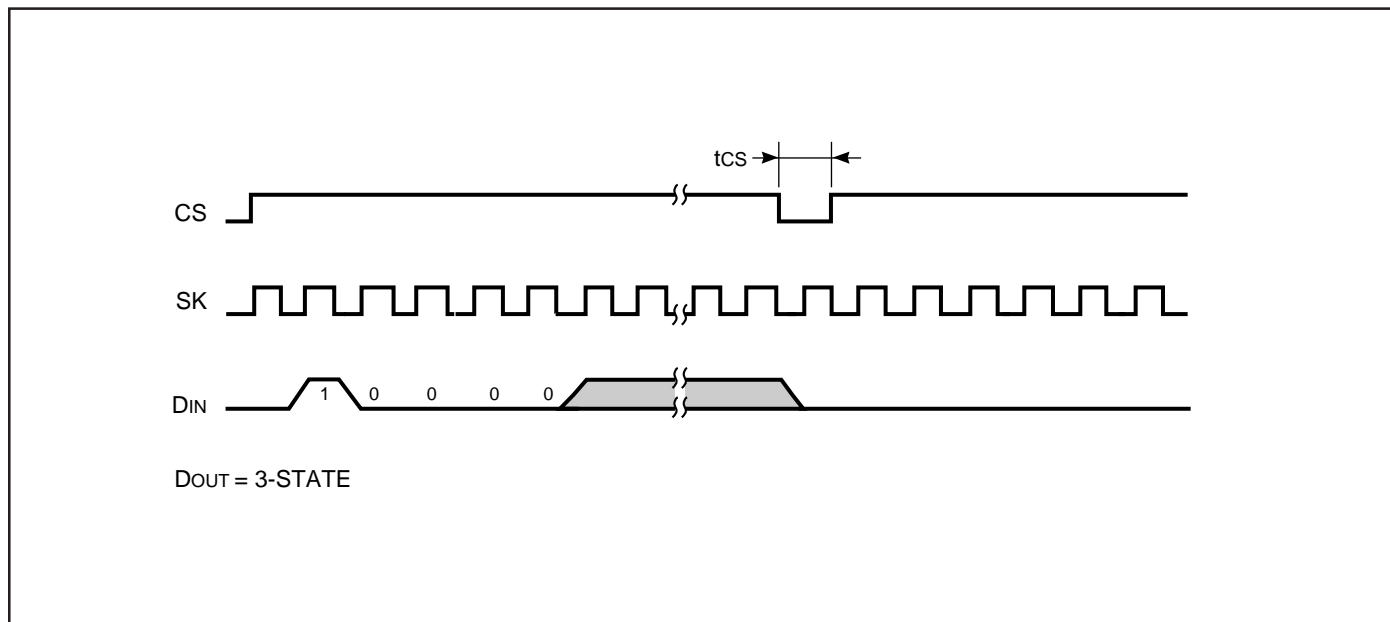

AC WAVEFORMS

FIGURE 8. ERASE (REGISTER ERASE) CYCLE TIMING

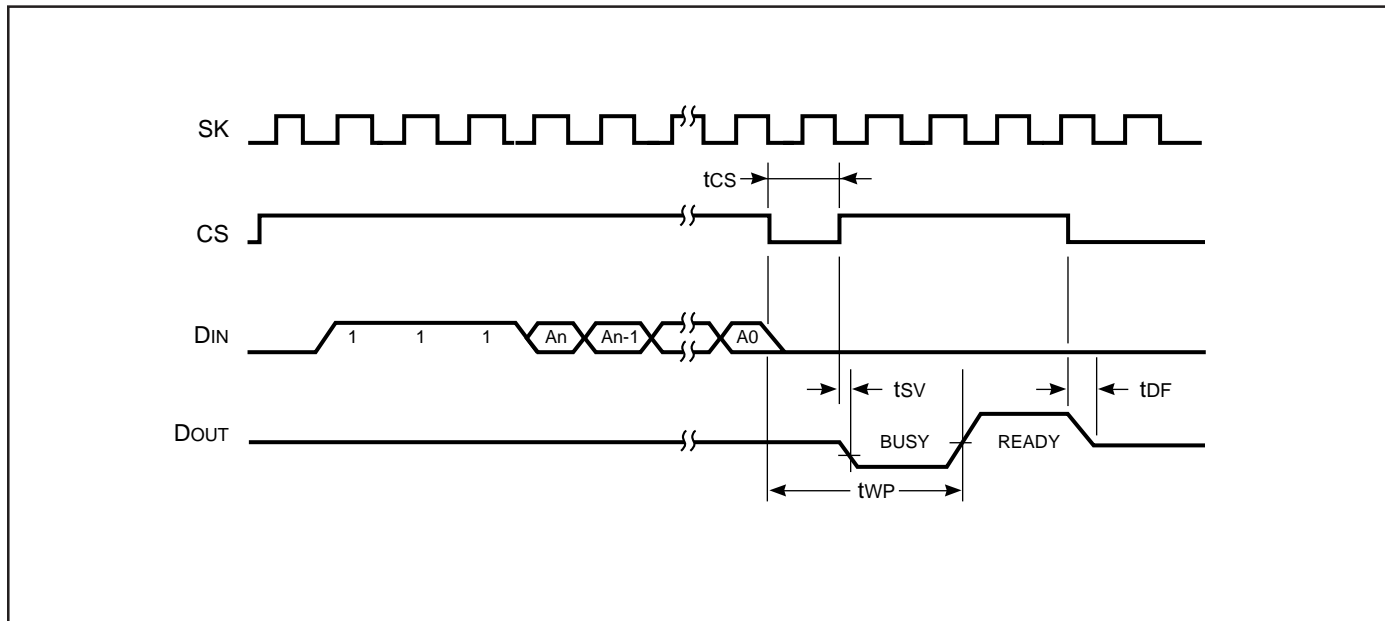

Notes:

To determine data bits An - A0, see Instruction Set for the appropriate device.

FIGURE 9. ERASE ALL (ERAL) CYCLE TIMING

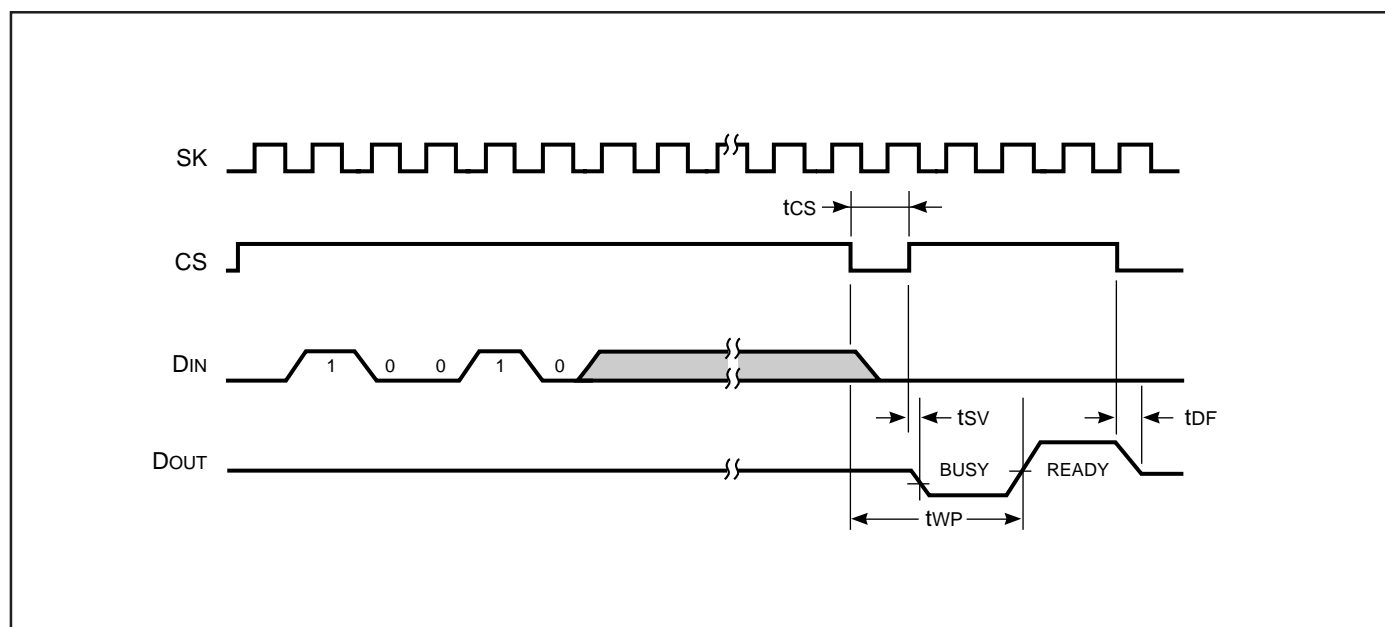

Note for Figures 8 and 9:

After the completion of the instruction (DOUT is in READY status) then it may perform another instruction. If device is in $\overline{\text{BUSY}}$ status (DOUT indicates $\overline{\text{BUSY}}$ status) then performs another instruction that would cause device malfunction.

ORDERING INFORMATION**Industrial Range: -40°C to +85°C**

Speed	Voltage Range	Order Part No.	Package
1Mhz	2.5V to 5.5V	IS93C46A-3PI	300-mil Plastic DIP
		IS93C46A-3GI	SOIC (rotated) JEDEC
		IS93C46A-3GRI	SOIC JEDEC
		IS93C46A-3ZI	169-mil TSSOP
1Mhz	2.5V to 5.5V	IS93C56A-3PI	300-mil Plastic DIP
		IS93C56A-3GI	SOIC (rotated) JEDEC
		IS93C56A-3GRI	SOIC JEDEC
		IS93C56A-3ZI	169-mil TSSOP
1Mhz	2.5V to 5.5V	IS93C66A-3PI	300-mil Plastic DIP
		IS93C66A-3GI	SOIC (rotated) JEDEC
		IS93C66A-3GRI	SOIC JEDEC
		IS93C66A-3ZI	169-mil TSSOP

ORDERING INFORMATION**Automotive Range: -40°C to +125°C**

Speed	Voltage Range	Order Part No.	Package
1Mhz	2.7V to 5.5V	IS93C46A-3PA	300-mil Plastic DIP
		IS93C46A-3GRA	SOIC JEDEC
1Mhz	2.7V to 5.5V	IS93C56A-3PA	300-mil Plastic DIP
		IS93C56A-3GRA	SOIC JEDEC
1Mhz	2.7V to 5.5V	IS93C66A-3PA	300-mil Plastic DIP
		IS93C66A-3GRA	SOIC JEDEC
2Mhz	4.5V to 5.5V	IS93C46A-PA	300-mil Plastic DIP
		IS93C46A-GRA	SOIC JEDEC
2Mhz	4.5V to 5.5V	IS93C56A-PA	300-mil Plastic DIP
		IS93C56A-GRA	SOIC JEDEC
2Mhz	4.5V to 5.5V	IS93C66A-PA	300-mil Plastic DIP
		IS93C66A-GRA	SOIC JEDEC