

DATA SHEET

E30/15/7

E cores and accessories

Supersedes data of February 2002

2004 Sep 01

CORE SETS

Effective core parameters

SYMBOL	PARAMETER	VALUE	UNIT
$\Sigma(l/A)$	core factor (C1)	1.12	mm ⁻¹
V_e	effective volume	4000	mm ³
l_e	effective length	67.0	mm
A_e	effective area	60.0	mm ²
A_{min}	minimum area	49.0	mm ²
m	mass of core half	≈ 11	g

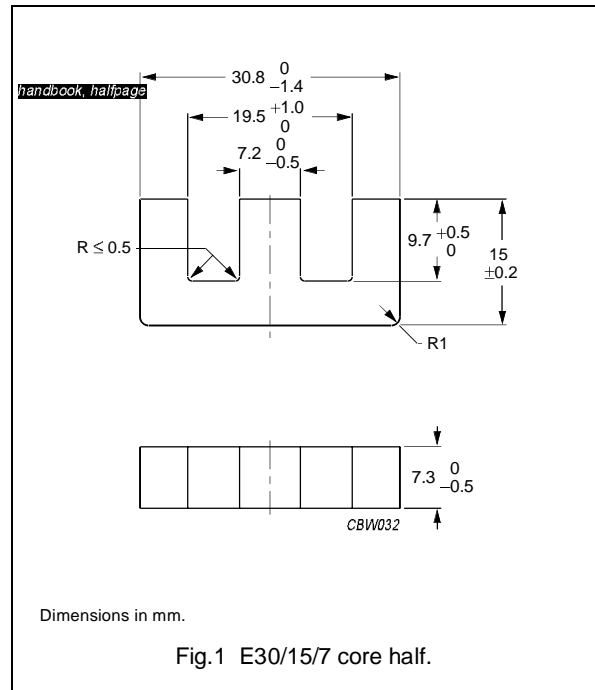

Core halves

A_L measured in combination with a non-gapped core half, clamping force for A_L measurements 20 ±10 N, unless stated otherwise.

GRADE	A_L (nH)	μ_e	AIR GAP (μm)	TYPE NUMBER
3C81	100 ±5% ⁽¹⁾	≈ 89	≈ 1100	E30/15/7-3C81-E100
	160 ±5%	≈142	≈ 580	E30/15/7-3C81-A160
	250 ±5%	≈ 222	≈ 330	E30/15/7-3C81-A250
	315 ±5%	≈ 280	≈ 240	E30/15/7-3C81-A315
	400 ±8%	≈ 355	≈ 180	E30/15/7-3C81-A400
	630 ±15%	≈ 560	≈ 100	E30/15/7-3C81-A630
	2500 ±25%	≈ 2220	≈ 0	E30/15/7-3C81
3C90	100 ±5% ⁽¹⁾	≈ 89	≈ 1100	E30/15/7-3C90-E100
	160 ±5%	≈142	≈ 580	E30/15/7-3C90-A160
	250 ±5%	≈ 222	≈ 330	E30/15/7-3C90-A250
	315 ±5%	≈ 280	≈ 240	E30/15/7-3C90-A315
	400 ±8%	≈ 355	≈ 180	E30/15/7-3C90-A400
	630 ±15%	≈ 560	≈ 100	E30/15/7-3C90-A630
	1900 ±25%	≈ 1690	≈ 0	E30/15/7-3C90
3C91 des	2500 ±25%	≈ 2220	≈ 0	E30/15/7-3C91
3C92 des	1400 ±25%	≈ 1250	≈ 0	E30/15/7-3C92
3C94	1900 ±25%	≈ 1690	≈ 0	E30/15/7-3C94
3C96 des	1600 ±25%	≈ 1420	≈ 0	E30/15/7-3C96

E cores and accessories

E30/15/7

GRADE	A_L (nH)	μ_e	AIR GAP (μm)	TYPE NUMBER
3F3	100 $\pm 5\%$ ⁽¹⁾	≈ 89	≈ 1100	E30/15/7-3F3-E100
	160 $\pm 5\%$	≈ 142	≈ 580	E30/15/7-3F3-A160
	250 $\pm 5\%$	≈ 222	≈ 330	E30/15/7-3F3-A250
	315 $\pm 5\%$	≈ 280	≈ 240	E30/15/7-3F3-A315
	400 $\pm 8\%$	≈ 355	≈ 180	E30/15/7-3F3-A400
	630 $\pm 15\%$	≈ 560	≈ 100	E30/15/7-3F3-A630
3F35 	1250 $\pm 25\%$	≈ 1110	≈ 0	E30/15/7-3F35

Note

1. Measured in combination with an equal gapped core half, clamping force for A_L measurements, 20 ± 10 N.

Core halves of high permeability gradesClamping force for A_L measurements 20 ± 10 N.

GRADE	A_L (nH)	μ_e	AIR GAP (μm)	TYPE NUMBER
3C11	3300 $\pm 25\%$	≈ 2930	≈ 0	E30/15/7-3C11
3E27	4100 $\pm 25\%$	≈ 3640	≈ 0	E30/15/7-3E27

E cores and accessories

E30/15/7

Properties of core sets under power conditions

GRADE	B (mT) at	CORE LOSS (W) at			
	H = 250 A/m; f = 25 kHz; T = 100 °C	f = 25 kHz; \hat{B} = 200 mT; T = 100 °C	f = 100 kHz; \hat{B} = 100 mT; T = 100 °C	f = 100 kHz; \hat{B} = 200 mT; T = 100 °C	f = 400 kHz; \hat{B} = 50 mT; T = 100 °C
3C81	≥320	≤ 0.82	–	–	–
3C90	≥330	≤ 0.45	≤ 0.48	–	–
3C91	≥320	–	≤ 0.27 ⁽¹⁾	≤ 1.6 ⁽¹⁾	–
3C92	≥370	–	≤ 0.36	≤ 2.0	–
3C94	≥330	–	≤ 0.36	≤ 2.0	–
3C96	≥340	–	≤ 0.27	≤ 1.6	–
3F3	≥320	–	≤ 0.47	–	≤ 0.80
3F35	≥300	–	–	–	–

Properties of core sets under power conditions (continued)

GRADE	B (mT) at	CORE LOSS (W) at			
	H = 250 A/m; f = 25 kHz; T = 100 °C	f = 500 kHz; \hat{B} = 50 mT; T = 100 °C	f = 500 kHz; \hat{B} = 100 mT; T = 100 °C	f = 1 MHz; \hat{B} = 30 mT; T = 100 °C	f = 3 MHz; \hat{B} = 10 mT; T = 100 °C
3C81	≥320	–	–	–	–
3C90	≥330	–	–	–	–
3C91	≥320	–	–	–	–
3C92	≥370	–	–	–	–
3C94	≥330	–	–	–	–
3C96	≥340	≤ 1.5	–	–	–
3F3	≥320	–	–	–	–
3F35	≥300	≤ 0.54	≤ 4.2	–	–

Note

1. Measured at 60 °C.

COIL FORMERS

GENERAL DATA FOR E30/15/7 COIL FORMER WITHOUT PINS

PARAMETER	SPECIFICATION
Coil former material	polyamide (PA6.6), glass reinforced, flame retardant in accordance with "UL 94-HB"; UL file number E41613(M)
Maximum operating temperature	120 °C

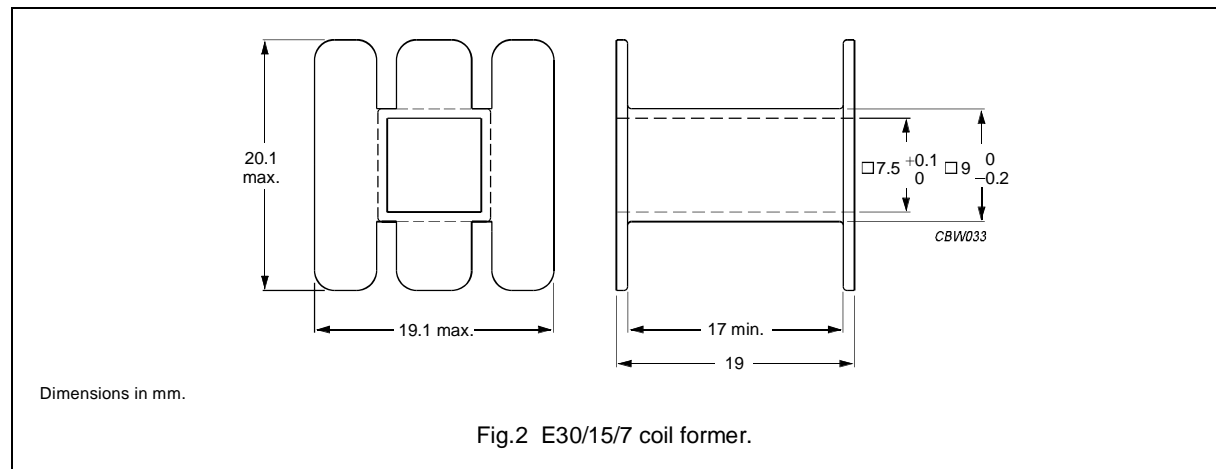

WINDING DATA FOR E30/15/7 COIL FORMER WITHOUT PINS (E)

NUMBER OF SECTIONS	WINDING AREA (mm ²)	MINIMUM WINDING WIDTH (mm)	AVERAGE LENGTH OF TURN (mm)	TYPE NUMBER
1	80	17.0	56	CP-E30/15/7-1S

GENERAL DATA FOR 10-PINS E30/15/7 COIL FORMER

PARAMETER	SPECIFICATION
Coil former material	phenolformaldehyde (PF), glass reinforced, flame retardant in accordance with "UL 94V-0"; UL file number E167521(M)
Pin material	copper-tin alloy (CuSn), tin-lead alloy (SnPb) plated, transition to lead-free (Sn) ongoing.
Maximum operating temperature	180 °C, "IEC 60085", class H
Resistance to soldering heat	"IEC 60068-2-20", Part 2, Test Tb, method 1B: 350 °C, 3.5 s
Solderability	"IEC 60068-2-20", Part 2, Test Ta, method 1: 235 °C, 2 s

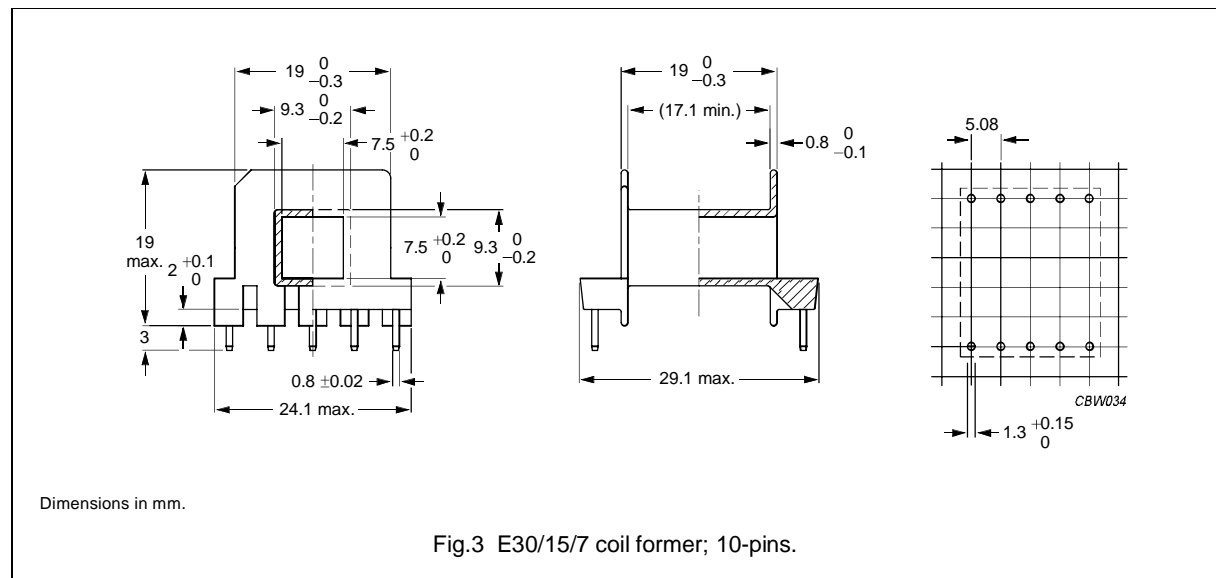

WINDING DATA FOR 10-PINS E30/15/7 COIL FORMER (E)

NUMBER OF SECTIONS	WINDING AREA (mm ²)	MINIMUM WINDING WIDTH (mm)	AVERAGE LENGTH OF TURN (mm)	TYPE NUMBER
1	80	17.1	56	CSH-E30/7-1S-10P

MOUNTING PARTS

General data and ordering information

ITEM	REMARKS	FIGURE	TYPE NUMBER
Clasp	CuZn alloy, Ni plated	4	CLA-E30/15/7
Spring	stainless steel (CrNi)	5	SPR-E30/15/7

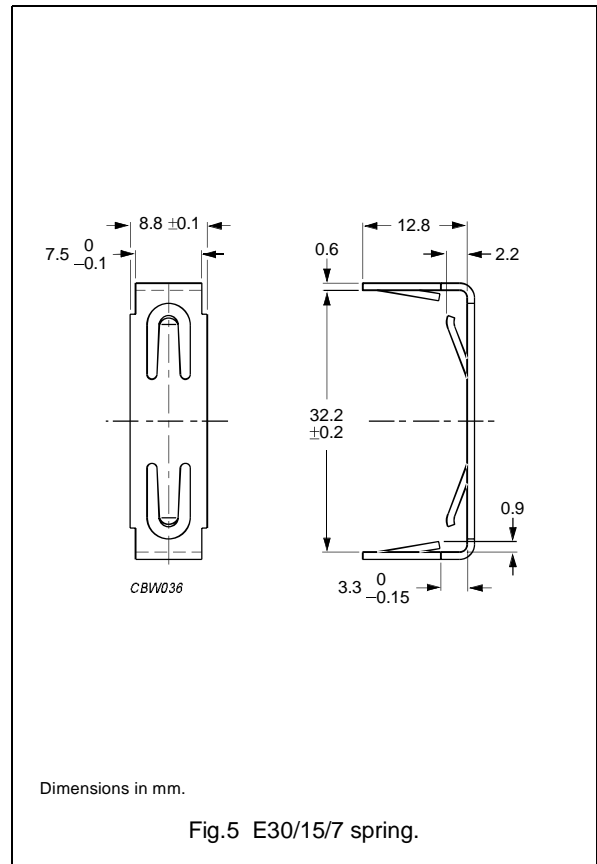
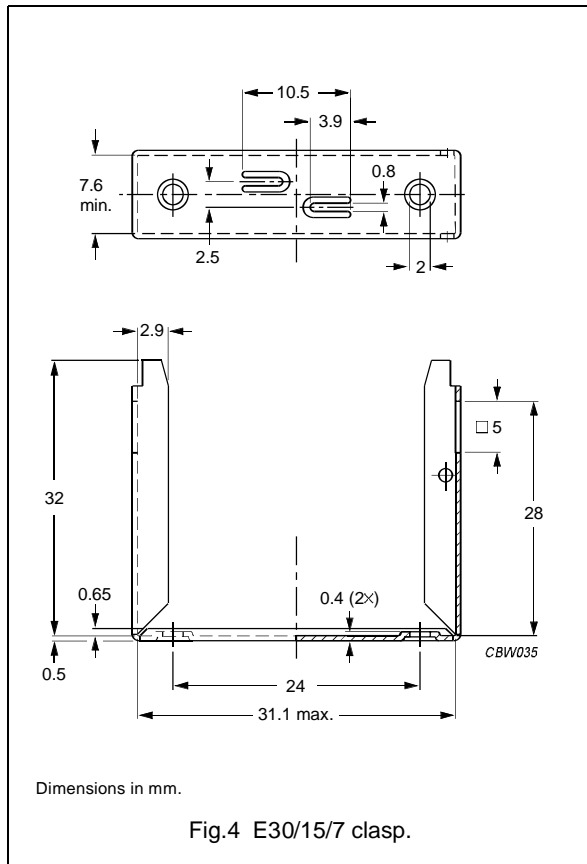

E cores and accessories

E30/15/7



DATA SHEET STATUS DEFINITIONS

DATA SHEET STATUS	PRODUCT STATUS	DEFINITIONS
Preliminary specification	Development	This data sheet contains preliminary data. Ferroxcube reserves the right to make changes at any time without notice in order to improve design and supply the best possible product.
Product specification	Production	This data sheet contains final specifications. Ferroxcube reserves the right to make changes at any time without notice in order to improve design and supply the best possible product.

DISCLAIMER

Life support applications — These products are not designed for use in life support appliances, devices, or systems where malfunction of these products can reasonably be expected to result in personal injury. Ferroxcube customers using or selling these products for use in such applications do so at their own risk and agree to fully indemnify Ferroxcube for any damages resulting from such application.

PRODUCT STATUS DEFINITIONS

STATUS	INDICATION	DEFINITION
Prototype		These are products that have been made as development samples for the purposes of technical evaluation only. The data for these types is provisional and is subject to change.
Design-in		These products are recommended for new designs.
Preferred		These products are recommended for use in current designs and are available via our sales channels.
Support		These products are not recommended for new designs and may not be available through all of our sales channels. Customers are advised to check for availability.