

4-Mbit (512K x 8) Static RAM

Features

- Very high speed: 45 ns
 - Wide voltage range: 2.20V – 3.60V
- Pin compatible with CY62148DV30
- Ultra low standby power
 - Typical standby current: 1 μ A
 - Maximum standby current: 7 μ A (Industrial)
- Ultra low active power
 - Typical active current: 2 mA @ f = 1 MHz
- Easy memory expansion with \overline{CE} , and \overline{OE} features
- Automatic power down when deselected
- CMOS for optimum speed and power
- Available in Pb-free 36-ball VFBGA, 32-pin TSOP II and 32-pin SOIC [1] packages

Functional Description [2]

The CY62148EV30 is a high performance CMOS static RAM organized as 512K words by 8 bits. This device features advanced circuit design to provide ultra low active current. This is ideal for providing More Battery Life™ (MoBL®) in portable applications such as cellular telephones. The device also has an automatic power down feature that significantly reduces power consumption. Placing the device into standby mode reduces power consumption by more than 99% when deselected (\overline{CE} HIGH). The eight input and output pins (IO_0 through IO_7) are placed in a high impedance state when the device is deselected (\overline{CE} HIGH), the outputs are disabled (\overline{OE} HIGH), or during a write operation (\overline{CE} LOW and \overline{WE} LOW).

To write to the device, take Chip Enable (\overline{CE}) and Write Enable (\overline{WE}) inputs LOW. Data on the eight IO pins (IO_0 through IO_7) is then written into the location specified on the address pins (A_0 through A_{18}).

To read from the device, take Chip Enable (\overline{CE}) and Output Enable (\overline{OE}) LOW while forcing Write Enable (\overline{WE}) HIGH. Under these conditions, the contents of the memory location specified by the address pins appear on the IO pins.

Logic Block Diagram

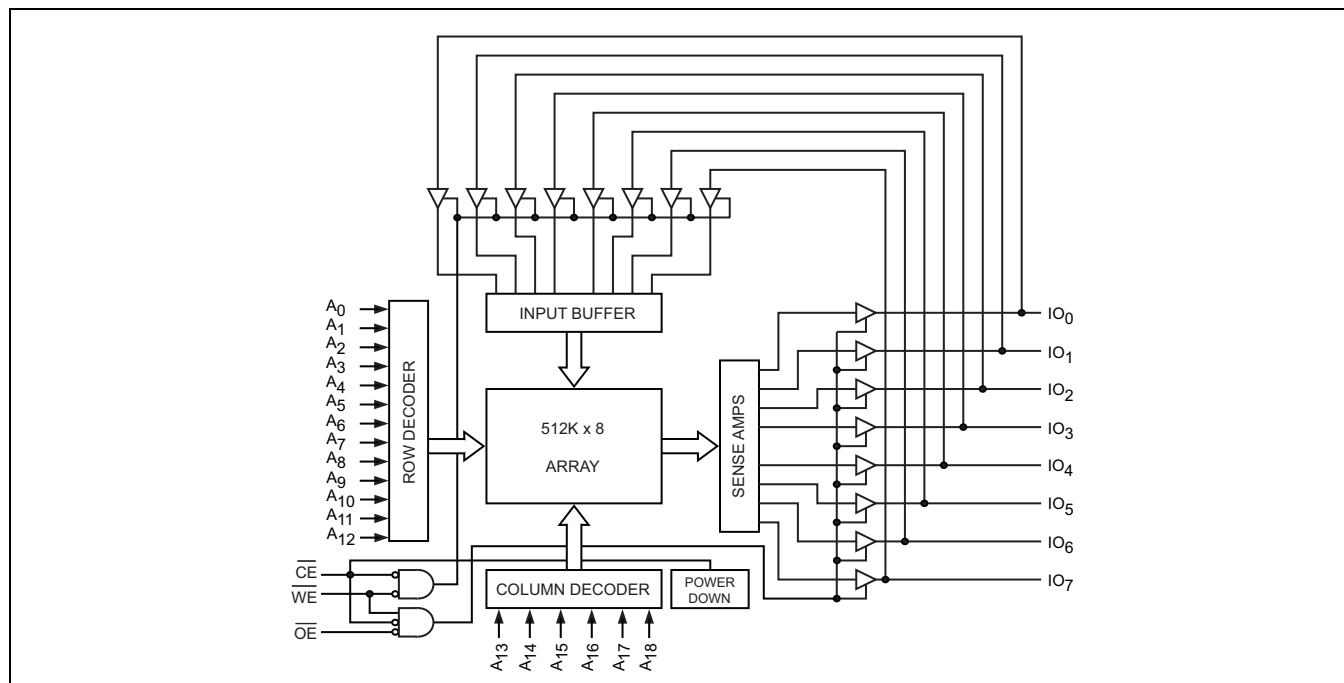

Notes

1. SOIC package is available only in 55 ns speed bin.
2. For best practice recommendations, refer to the Cypress application note "System Design Guidelines" at <http://www.cypress.com>.

Pin Configuration [1, 3]

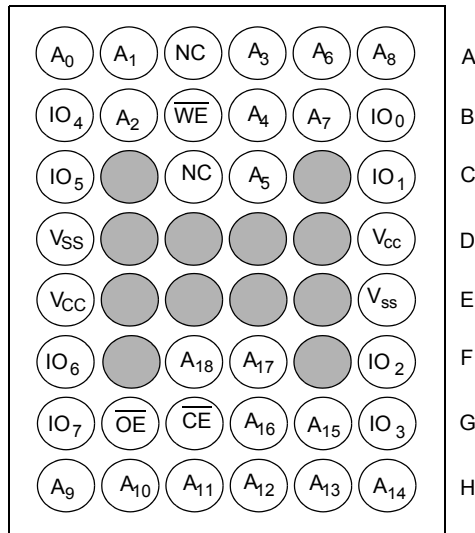
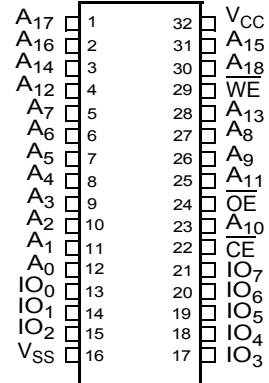
36-Ball VFBGA Pinout
Top View

32-Pin SOIC/TSOP II Pinout
Top View

Product Portfolio

Product	Range	V _{CC} Range (V)	Speed (ns)	Power Dissipation								
				Operating I _{CC} (mA)				Standby I _{SB2} (μA)				
				f = 1 MHz		f = f _{max}						
				Min	Typ ^[4]	Max	Typ ^[4]	Max	Typ ^[4]	Max		
CY62148EV30LL	VFBGA	Industrial	45	2.2	3.0	3.6	2	2.5	15	20	1	7
	TSOP II											
CY62148EV30LL	SOIC	Industrial	55	2.2	3.0	3.6	2	2.5	15	20	1	7

Notes

3. NC pins are not connected on the die.

 4. Typical values are included for reference only and are not guaranteed or tested. Typical values are measured at V_{CC} = V_{CC(typ)}, T_A = 25°C.

Maximum Ratings

Exceeding maximum ratings may impair the useful life of the device. These user guidelines are not tested.

Storage Temperature -65°C to +150°C

Ambient Temperature with Power Applied 55°C to +125°C

Supply Voltage to Ground Potential -0.3V to $V_{CC(max)}$ + 0.3V

DC Voltage Applied to Outputs in High-Z State ^[5, 6] -0.3V to $V_{CC(max)}$ + 0.3V

DC Input Voltage ^[5, 6] -0.3V to $V_{CC(max)}$ + 0.3V

Output Current into Outputs (LOW) 20 mA

Static Discharge Voltage > 2001V (MIL-STD-883, Method 3015)

Latch up Current > 200 mA

Operating Range

Product	Range	Ambient Temperature	V_{CC} ^[7]
CY62148EV30	Industrial	-40°C to +85°C	2.2V to 3.6V

Electrical Characteristics (Over the Operating Range)

Parameter	Description	Test Conditions	45 ns			55 ns ^[1]			Unit	
			Min	Typ ^[4]	Max	Min	Typ ^[4]	Max		
V _{OH}	Output HIGH Voltage	I _{OH} = -0.1 mA	2.0			2.0			V	
		I _{OH} = -1.0 mA, V _{CC} ≥ 2.70V	2.4			2.4			V	
V _{OL}	Output LOW Voltage	I _{OL} = 0.1 mA			0.4			0.2	V	
		I _{OL} = 2.1 mA, V _{CC} ≥ 2.70V			0.4			0.4	V	
V _{IH}	Input HIGH Voltage	V _{CC} = 2.2V to 2.7V	1.8		V _{CC} + 0.3V	1.8		V _{CC} + 0.3V	V	
		V _{CC} = 2.7V to 3.6V	2.2		V _{CC} + 0.3V	2.2		V _{CC} + 0.3V	V	
V _{IL}	Input LOW Voltage	V _{CC} = 2.2V to 2.7V	For VFBGA and TSOP II package	-0.3		0.6			V	
			For SOIC package				-0.3		0.4 ^[8]	V
		V _{CC} = 2.7V to 3.6V	For VFBGA and TSOP II package	-0.3		0.8				V
			For SOIC package				-0.3		0.6 ^[8]	
I _{Ix}	Input Leakage Current	GND ≤ V _I ≤ V _{CC}	-1		+1	-1		+1	μA	
I _{OZ}	Output Leakage Current	GND ≤ V _O ≤ V _{CC} , Output Disabled	-1		+1	-1		+1	μA	
I _{CC}	V _{CC} Operating Supply Current	f = f _{max} = 1/t _{RC}	V _{CC} = V _{CC(max)} , I _{OUT} = 0 mA, CMOS levels		15	20		15	20	mA
		f = 1 MHz			2	2.5		2	2.5	
I _{SB1}	Automatic CE Power Down Current—CMOS Inputs	$\overline{CE} \geq V_{CC} - 0.2V$, $V_{IN} \geq V_{CC} - 0.2V$, $V_{IN} \leq 0.2V$ f = f _{max} (Address and Data Only), f = 0 (OE and WE), V _{CC} = 3.60V		1	7		1	7	μA	
I _{SB2} ^[9]	Automatic CE Power Down Current—CMOS Inputs	$\overline{CE} \geq V_{CC} - 0.2V$, $V_{IN} \geq V_{CC} - 0.2V$ or $V_{IN} \leq 0.2V$, f = 0, V _{CC} = 3.60V		1	7		1	7	μA	

Notes

- V_{IL(min)} = -2.0V for pulse durations less than 20 ns.
- V_{IH(max)} = V_{CC} + 0.75V for pulse durations less than 20 ns.
- Full device AC operation assumes a minimum of 100 μs ramp time from 0 to V_{CC(min)} and 200 μs wait time after V_{CC} stabilization.
- Under DC conditions the device meets a V_{IL} of 0.8V (for V_{CC} range of 2.7V to 3.6V) and 0.6V (for V_{CC} range of 2.2V to 2.7V). However, in dynamic conditions Input LOW voltage applied to the device must not be higher than 0.6V and 0.4V for the above ranges. This is applicable to SOIC package only. Please refer to AN13470 for details.
- Only chip enable (\overline{CE}) must be HIGH at CMOS level to meet the I_{SB2} / I_{CCDR} spec. Other inputs can be left floating.

Capacitance (For All packages) ^[10]

Parameter	Description	Test Conditions	Max	Unit
C _{IN}	Input Capacitance	T _A = 25°C, f = 1 MHz,	10	pF
C _{OUT}	Output Capacitance	V _{CC} = V _{CC(typ)}	10	pF

Thermal Resistance ^[10]

Parameter	Description	Test Conditions	VFBGA Package	TSOP II Package	SOIC Package	Unit
Θ _{JA}	Thermal Resistance (Junction to Ambient)	Still Air, soldered on a 3 x 4.5 inch, two-layer printed circuit board	72	75.13	55	°C/W
Θ _{JC}	Thermal Resistance (Junction to Case)		8.86	8.95	22	°C/W

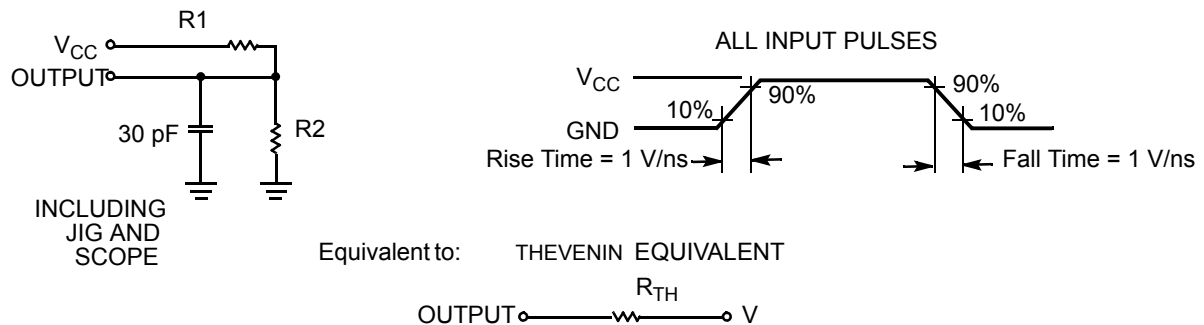
AC Test Loads and Waveforms

Parameters	2.50V	3.0V	Unit
R1	16667	1103	Ω
R2	15385	1554	Ω
R _{TH}	8000	645	Ω
V _{TH}	1.20	1.75	V

Data Retention Characteristics (Over the Operating Range)

Parameter	Description	Conditions	Min	Typ ^[4]	Max	Unit
V _{DR}	V _{CC} for Data Retention		1.5			V
I _{CCDR} ^[9]	Data Retention Current	V _{CC} = 1.5V, $\overline{CE} \geq V_{CC} - 0.2V$, V _{IN} ≥ V _{CC} - 0.2V or V _{IN} ≤ 0.2V		0.8	7	μA
t _{CDR} ^[10]	Chip Deselect to Data Retention Time		0			ns
t _R ^[11]	Operation Recovery Time		t _{RC}			ns

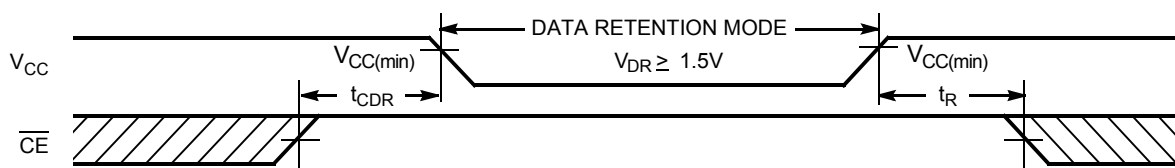
Data Retention Waveform

Notes

10. Tested initially and after any design or process changes that may affect these parameters.
 11. Full device AC operation requires linear V_{CC} ramp from V_{DR} to V_{CC(min)} ≥ 100 μs or stable at V_{CC(min)} ≥ 100 μs.

Switching Characteristics (Over the Operating Range) ^[12]

Parameter	Description	45 ns		55 ns ^[1]		Unit
		Min	Max	Min	Max	
Read Cycle						
t _{RC}	Read Cycle Time	45		55		ns
t _{AA}	Address to Data Valid		45		55	ns
t _{OHA}	Data Hold from Address Change	10		10		ns
t _{ACE}	$\overline{\text{CE}}$ LOW to Data Valid		45		55	ns
t _{DOE}	$\overline{\text{OE}}$ LOW to Data Valid		22		25	ns
t _{LZOE}	$\overline{\text{OE}}$ LOW to Low Z ^[13]	5		5		ns
t _{HZOE}	$\overline{\text{OE}}$ HIGH to High Z ^[13, 14]		18		20	ns
t _{LZCE}	$\overline{\text{CE}}$ LOW to Low Z ^[13]	10		10		ns
t _{HZCE}	$\overline{\text{CE}}$ HIGH to High Z ^[13, 14]		18		20	ns
t _{PU}	$\overline{\text{CE}}$ LOW to Power Up	0		0		ns
t _{PD}	$\overline{\text{CE}}$ HIGH to Power Up		45		55	ns
Write Cycle ^[15]						
t _{WC}	Write Cycle Time	45		55		ns
t _{SCE}	$\overline{\text{CE}}$ LOW to Write End	35		40		ns
t _{AW}	Address Setup to Write End	35		40		ns
t _{HA}	Address Hold from Write End	0		0		ns
t _{SA}	Address Setup to Write Start	0		0		ns
t _{PWE}	$\overline{\text{WE}}$ Pulse Width	35		40		ns
t _{SD}	Data Setup to Write End	25		25		ns
t _{HD}	Data Hold from Write End	0		0		ns
t _{HZWE}	$\overline{\text{WE}}$ LOW to High Z ^[13, 14]		18		20	ns
t _{LZWE}	$\overline{\text{WE}}$ HIGH to Low Z ^[13]	10		10		ns

Notes

12. Test Conditions for all parameters other than tri-state parameters assume signal transition time of 3 ns or less (1 V/ns), timing reference levels of $V_{CC(typ)}/2$, input pulse levels of 0 to $V_{CC(typ)}$, and output loading of the specified I_{OL}/I_{OH} as shown in the "AC Test Loads and Waveforms" on page 4.
13. At any given temperature and voltage condition, t_{HZCE} is less than t_{LZCE}, t_{HZOE} is less than t_{LZOE}, and t_{HZWE} is less than t_{LZWE} for any given device.
14. t_{HZOE}, t_{HZCE}, and t_{HZWE} transitions are measured when the output enter a high impedance state.
15. The internal write time of the memory is defined by the overlap of $\overline{\text{WE}}$, $\overline{\text{CE}} = V_{IL}$. All signals must be ACTIVE to initiate a write and any of these signals can terminate a write by going INACTIVE. The data input setup and hold timing must be referenced to the edge of the signal that terminates the write.

Switching Waveforms

Read Cycle No. 1 (Address Transition Controlled) [16, 17]

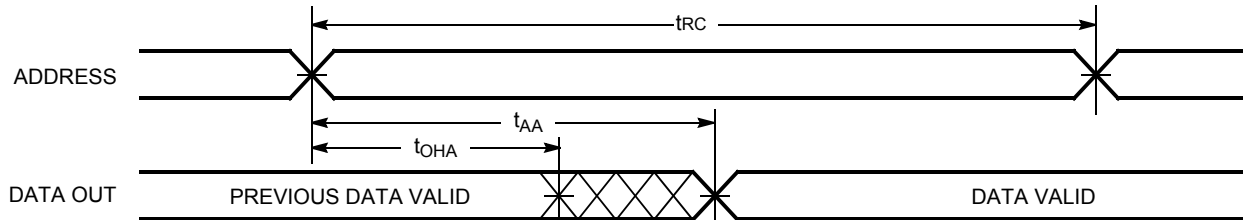

Read Cycle No. 2 ($\overline{\text{OE}}$ Controlled) [17, 18]

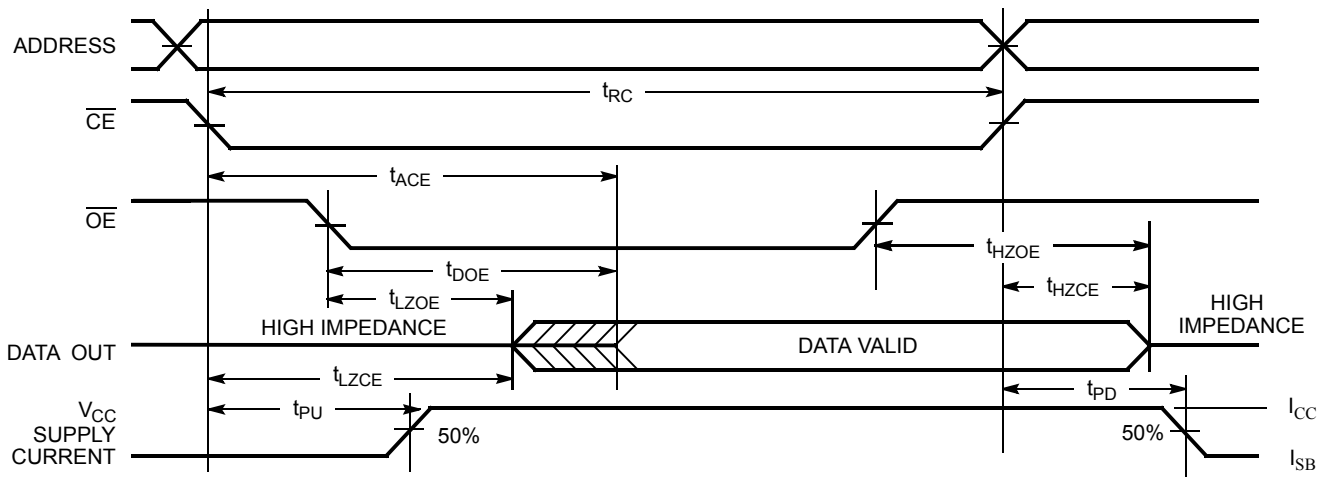

Write Cycle No. 1 ($\overline{\text{WE}}$ Controlled, $\overline{\text{OE}}$ HIGH During Write) [19, 20]

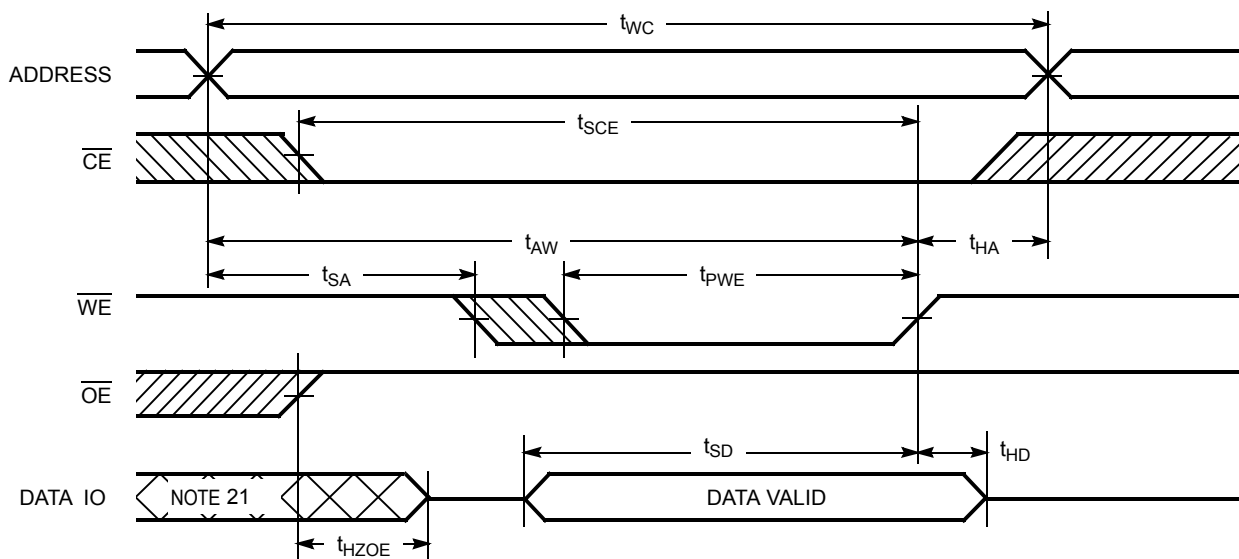

Notes

- 16. Device is continuously selected. $\overline{\text{OE}}, \overline{\text{CE}} = V_{\text{IL}}$.
- 17. $\overline{\text{WE}}$ is HIGH for read cycles.
- 18. Address valid before or similar to $\overline{\text{CE}}$ transition LOW.
- 19. Data IO is high impedance if $\overline{\text{OE}} = V_{\text{IH}}$.
- 20. If $\overline{\text{CE}}$ goes HIGH simultaneously with $\overline{\text{WE}}$ HIGH, the output remains in high impedance state.
- 21. During this period, the IOs are in output state. Do not apply input signals.

Switching Waveforms (continued)

Write Cycle No. 2 (\overline{CE} Controlled) [19, 20]

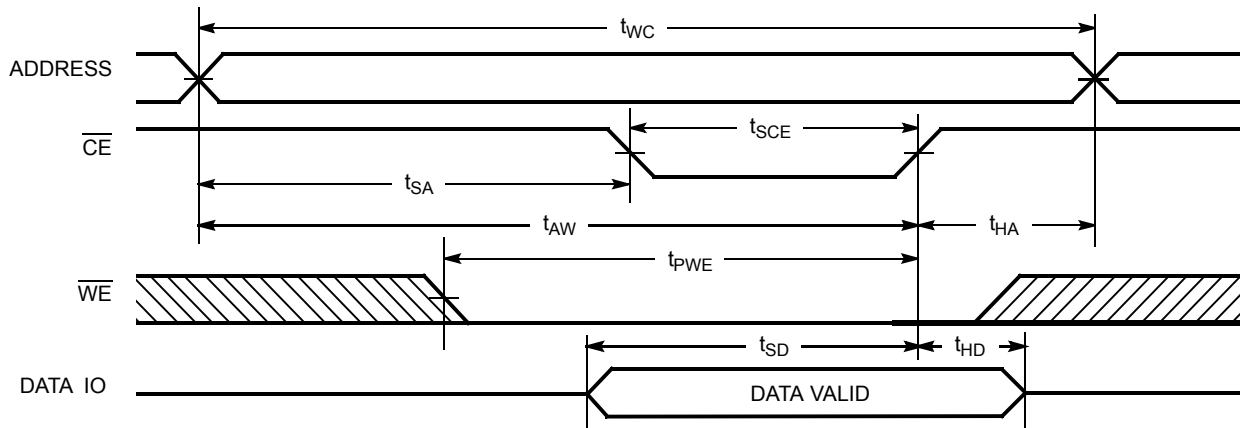

Write Cycle No. 3 (\overline{WE} Controlled, \overline{OE} LOW) [20]

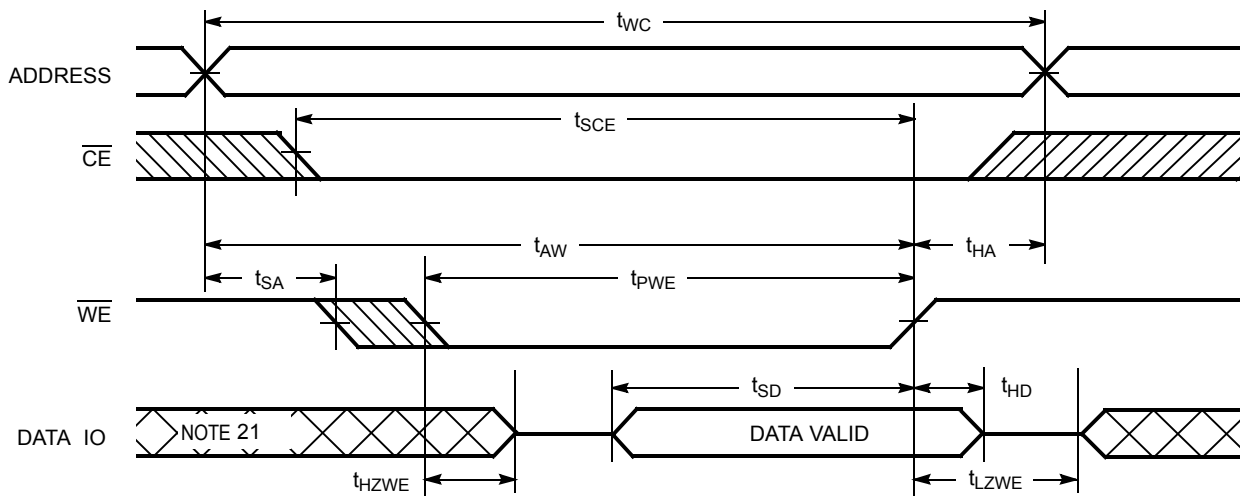

Truth Table

\overline{CE}	\overline{WE}	\overline{OE}	Inputs/Outputs	Mode	Power
H	X	X	High Z	Deselect/Power down	Standby (I_{SB})
L	H	L	Data Out	Read	Active (I_{CC})
L	H	H	High Z	Output Disabled	Active (I_{CC})
L	L	X	Data in	Write	Active (I_{CC})

Ordering Information

Speed (ns)	Ordering Code	Package Diagram	Package Type	Operating Range
45	CY62148EV30LL-45BVXI	51-85149	36-ball Very Fine Pitch Ball Grid Array (Pb-free)	Industrial
	CY62148EV30LL-45ZSXI	51-85095	32-pin Thin Small Outline Package II (Pb-free)	
55	CY62148EV30LL-55SXI	51-85081	32-pin Small Outline Integrated Circuit (Pb-free)	

Contact your local Cypress sales representative for availability of these parts.

Package Diagrams

Figure 1. 36-ball VFBGA (6 x 8 x 1 mm), 51-85149

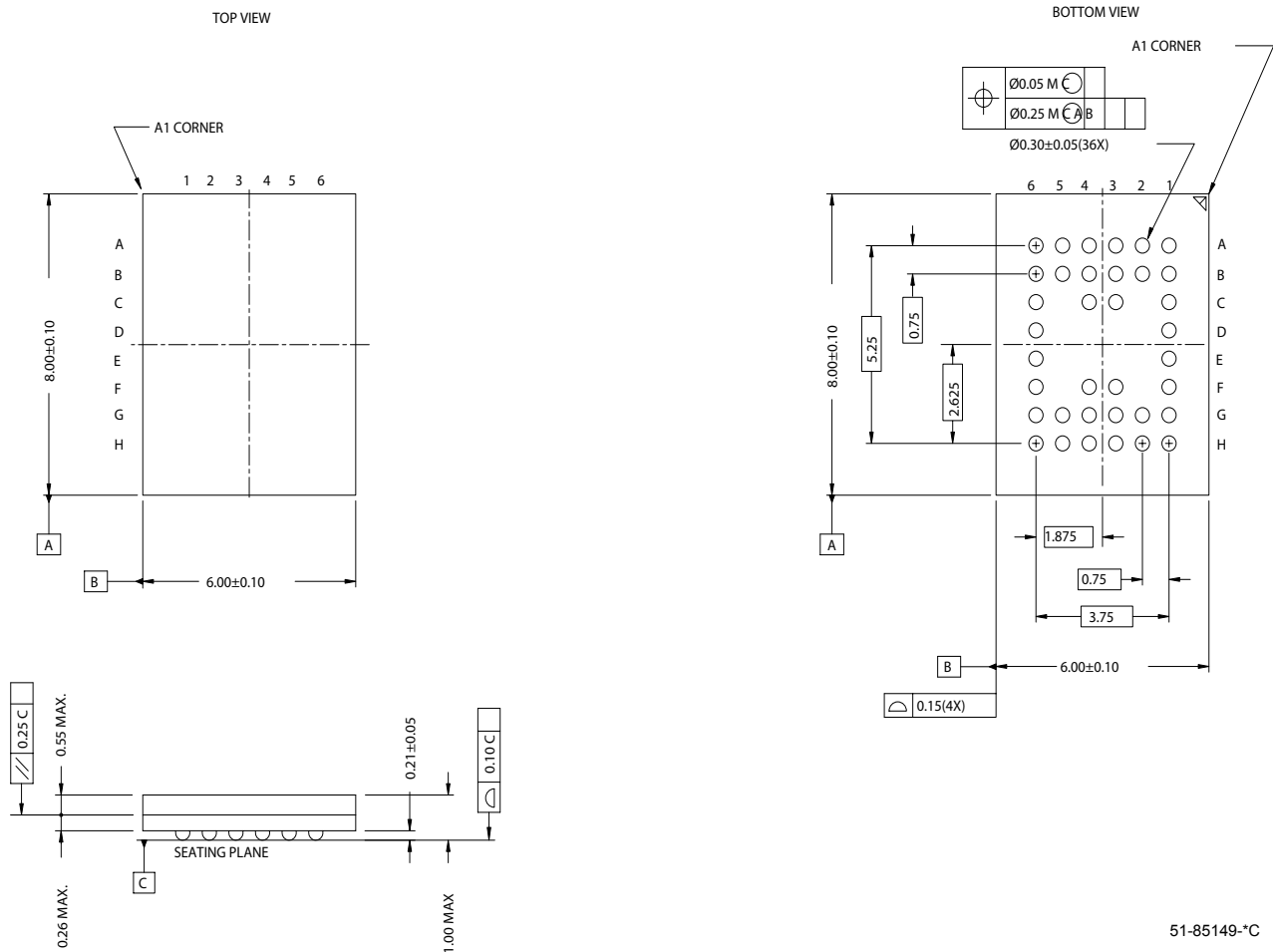

51-85149-1C

Package Diagrams (continued)

Figure 2. 32-pin TSOP II, 51-85095

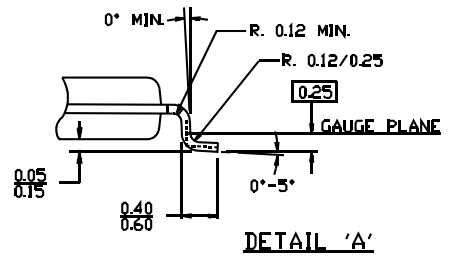
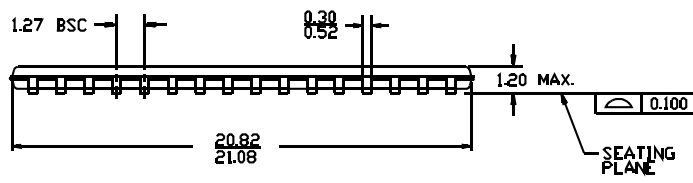
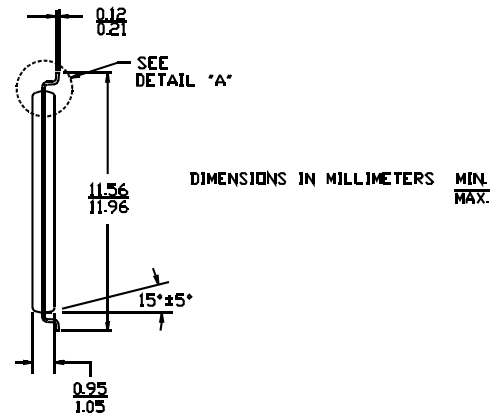
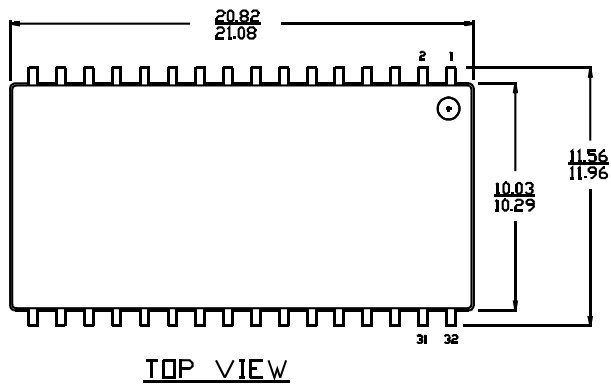

51-85095-**

Package Diagrams (continued)

Figure 3. 32-pin (450 MIL) Molded SOIC, 51-85081

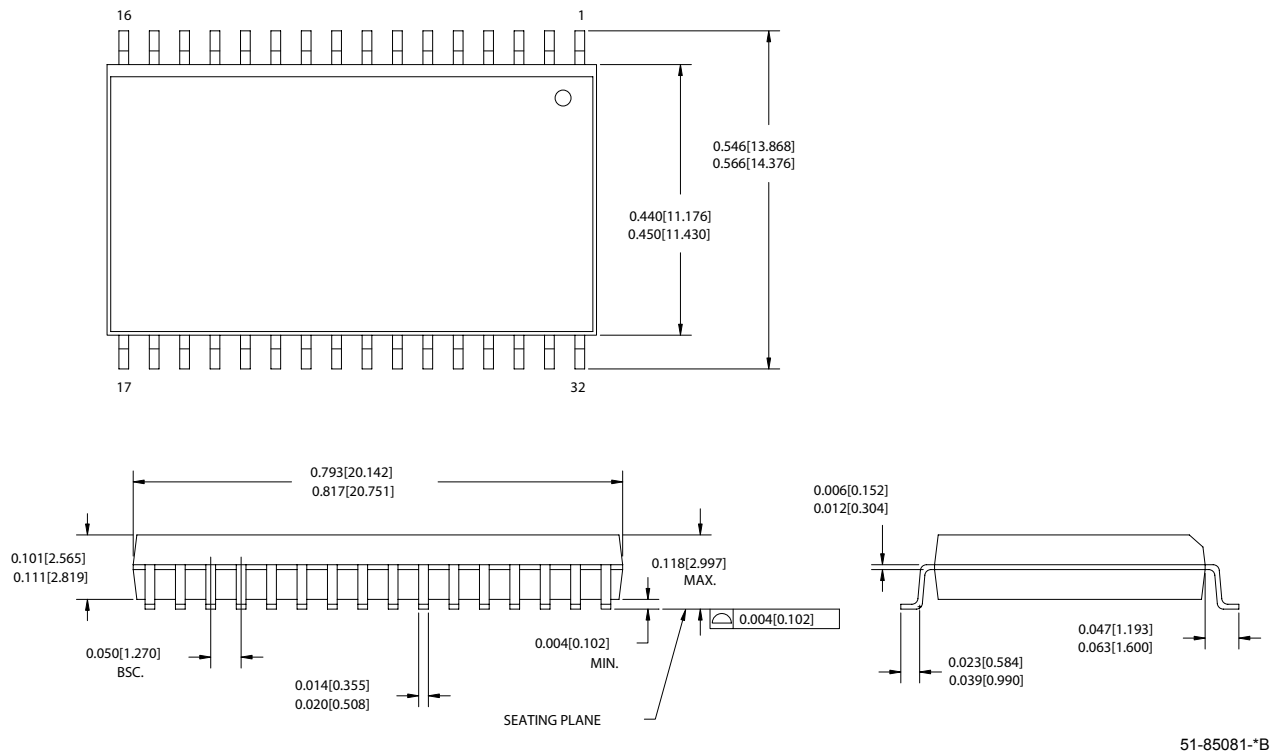

51-85081-B

MoBL is a registered trademark, and More Battery Life is a trademark of Cypress Semiconductor. All product and company names mentioned in this document are the trademarks of their respective holders.

Document History Page

Document Title: CY62148EV30 MoBL [®] , 4-Mbit (512K x 8) Static RAM				
Document Number: 38-05576				
REV.	ECN NO.	Issue Date	Orig. of Change	Description of Change
**	223225	See ECN	AJU	New data sheet
*A	247373	See ECN	SYT	Changed from Advance Information to Preliminary Moved Product Portfolio to Page 2 Changed V _{CC} stabilization time in footnote #7 from 100 μs to 200 μs Changed I _{CCDR} from 2.0 μA to 2.5 μA Changed t _{typo} in Data Retention Characteristics (t _R) from 100 μs to t _{RC} ns Changed t _{OHA} from 6 ns to 10 ns for both 35 ns and 45 ns Speed Bin Changed t _{HZOE} , t _{HZWE} from 12 to 15 ns for 35 ns Speed Bin and 15 to 18 ns for 45 ns Speed Bin Changed t _{SCE} from 25 to 30 ns for 35 ns Speed Bin and 40 to 35 ns for 45 ns Speed Bin Changed t _{HZCE} from 12 to 18 ns for 35 ns Speed Bin and 15 to 22 ns for 45 ns Speed Bin Changed t _{SD} from 15 to 18 ns for 35 ns Speed Bin and 20 to 22 ns for 45 ns Speed Bin Changed t _{DOE} from 15 to 18 ns for 35 ns Speed Bin Changed Ordering Information to include Pb-Free Packages
*B	414807	See ECN	ZSD	Changed from Preliminary information to Final Changed the address of Cypress Semiconductor Corporation on Page #1 from "3901 North First Street" to "198 Champion Court" Removed 35ns Speed Bin Removed "L" version of CY62148EV30 Changed ball C3 from DNU to NC. Removed the redundant footnote on DNU. Changed I _{CC} (max) value from 2 mA to 2.5 mA and I _{CC} (Typ) value from 1.5 mA to 2 mA at f=1 MHz Changed I _{CC} (Typ) value from 12 mA to 15 mA at f = f _{max} Changed I _{SB1} and I _{SB2} Typ values from 0.7 μA to 1 μA and Max values from 2.5 μA to 7 μA. Changed the AC test load capacitance value from 50pF to 30pF. Changed I _{CCDR} from 2.5 μA to 7 μA. Added I _{CCDR} typical value. Changed t _{LZOE} from 3 ns to 5 ns Changed t _{LZCE} and t _{LZWE} from 6 ns to 10 ns Changed t _{HZCE} from 22 ns to 18 ns Changed t _{PWE} from 30 ns to 35 ns. Changed t _{SD} from 22 ns to 25 ns. Updated the package diagram 36-pin VFBGA from *B to *C Added 32-pin SOIC package diagram and pin diagram Updated the ordering information table and replaced the Package Name column with Package Diagram.
*C	464503	See ECN	NXR	Included Automotive Range in product offering Updated Thermal Resistance table Updated the Ordering Information
*D	833080	See ECN	VKN	Added footnote #8 Added V _{IL} spec for SOIC package
*E	890962	See ECN	VKN	Removed Automotive part and its related information Added footnote #2 related to SOIC package Added footnote #9 related to I _{SB2} Added AC values for 55 ns Industrial-SOIC range Updated Ordering Information table

Document Title: CY62148EV30 MoBL[®], 4-Mbit (512K x 8) Static RAM				
Document Number: 38-05576				
REV.	ECN NO.	Issue Date	Orig. of Change	Description of Change
*F	987940	See ECN	VKN	Changed V_{OL} spec from 0.4V to 0.2V for SOIC package at $I_{OL} = 0.1$ mA Changed V_{IL} spec from 0.6V to 0.4V for SOIC package at $V_{CC} = 2.2V$ to 2.7V Updated footnote #8 Made footnote #9 applicable for both I_{SB2} and I_{CCDR}