

# AN78xxNSP Series

## 3-pin positive output voltage regulator (1 A type)

### ■ Overview

The AN78xxNSP series is a 3-pin fixed positive output voltage regulator housed in surface mounting package. Stabilized fixed output voltage is obtained from unstable DC input voltage with using minimum external components. 9 types of fixed output voltage are available; 5 V, 6 V, 7 V, 8 V, 9 V, 10 V, 12 V, 15 V and 18 V. They can be used widely in power circuits with current capacity up to 1 A.

### ■ Features

- Output voltage: 5V, 6V, 7V, 8V, 9V, 10V, 12V, 15V, 18V
- Built-in overcurrent limit circuit
- Built-in thermal overload protection circuit
- Built-in ASO (area of safe operation) protection circuit

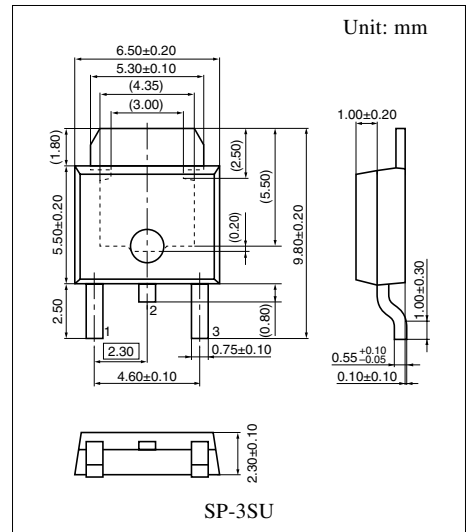

### ■ Block Diagram

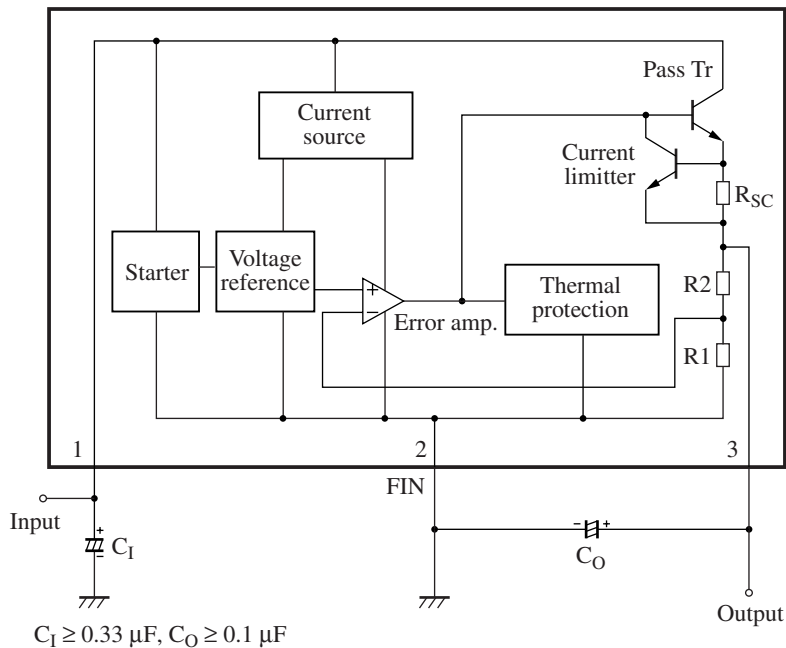

### ■ Pin Descriptions

Pin No.		Description
1	Input	Input voltage pin
2	GND	Ground pin (FIN)
3	Output	Output voltage pin

### ■ Absolute Maximum Ratings

Parameter	Symbol	Range	Unit
Supply voltage	$V_{CC}$	35	V
Supply current	$I_{CC}$	—	mA
Power dissipation *2	$P_D$	364	mW
Operating ambient temperature *1	$T_{opr}$	-30 to +85	°C
Storage temperature *1	$T_{stg}$	-55 to +150	°C

Note) 1. \*1: Except for the operating ambient temperature and storage temperature, all ratings are for  $T_a = 25^\circ\text{C}$ .

\*2: The power dissipation shown is the value for the independent IC without a heat sink at  $T_a = 85^\circ\text{C}$ .

When  $T_j$  exceeds  $150^\circ\text{C}$  (designed value), the internal circuit cuts off the output.

2. This IC is not suitable for car electronics equipment.

### ■ Electrical Characteristics at $T_a = 25^\circ\text{C}$

#### • AN7805NSP (5 V type)

The specified condition  $T_j = 25^\circ\text{C}$  means that the test should be carried out within so short a test time (within 10 ms) that the characteristic value drift due to the chip junction temperature rise can be ignored.

Unless otherwise specified,  $V_I = 10\text{ V}$ ,  $I_O = 500\text{ mA}$ ,  $C_I = 0.33\text{ }\mu\text{F}$  and  $C_O = 0.1\text{ }\mu\text{F}$

Parameter	Symbol	Conditions	Min	Typ	Max	Unit
Output voltage	$V_{O1}$	$T_j = 25^\circ\text{C}$	4.8	5	5.2	V
Output voltage tolerance	$V_{O2}$	$V_I = 8\text{ V to }20\text{ V}$ , $I_O = 5\text{ mA to }1\text{ A}$ $T_j = 25^\circ\text{C}$ , $P_D < 5\text{ W}$	4.75	—	5.25	V
Line regulation 1	$REG_{IN1}$	$V_I = 7.5\text{ V to }25\text{ V}$ , $T_j = 25^\circ\text{C}$	—	3	100	mV
Line regulation 2	$REG_{IN2}$	$V_I = 8\text{ V to }12\text{ V}$ , $T_j = 25^\circ\text{C}$	—	1	50	mV
Load regulation 1	$REG_{L1}$	$I_O = 5\text{ mA to }1.5\text{ A}$ , $T_j = 25^\circ\text{C}$	—	15	100	mV
Load regulation 2	$REG_{L2}$	$I_O = 250\text{ mA to }750\text{ mA}$ , $T_j = 25^\circ\text{C}$	—	5.0	50	mV
Bias current	$I_{Bias}$	$T_j = 25^\circ\text{C}$	—	3.9	8	mA
Bias current fluctuation to input	$\Delta I_{Bias(IN)}$	$V_I = 7.5\text{ V to }25\text{ V}$ , $T_j = 25^\circ\text{C}$	—	—	1.3	mA
Bias current fluctuation to load	$\Delta I_{Bias(L)}$	$I_O = 5\text{ mA to }1\text{ A}$ , $T_j = 25^\circ\text{C}$	—	—	0.5	mA
Ripple rejection ratio	RR	$V_I = 8\text{ V to }18\text{ V}$ , $I_O = 100\text{ mA}$ , $f = 120\text{ Hz}$	62	—	—	dB

#### • Design reference data

Note) The characteristics listed below are theoretical values based on the IC design and are not guaranteed.

Parameter	Symbol	Conditions	Min	Typ	Max	Unit
Output noise voltage	$V_{NO}$	$f = 10\text{ Hz to }100\text{ kHz}$	—	40	—	$\mu\text{V}$
Minimum input/output voltage difference	$V_{DIF(min)}$	$I_O = 1\text{ A}$ , $T_j = 25^\circ\text{C}$	—	2	—	V
Output short-circuit current	$I_{O(Short)}$	$V_I = 35\text{ V}$ , $T_j = 25^\circ\text{C}$	—	700	—	mA
Peak output current	$I_{O(Peak)}$	$T_j = 25^\circ\text{C}$	—	2.0	—	A
Output voltage temperature coefficient	$\Delta V_O / T_a$	$I_O = 5\text{ mA}$ , $T_j = 0^\circ\text{C to }125^\circ\text{C}$	—	-0.3	—	$\text{mV}/^\circ\text{C}$
Thermal protection operating temperature	$T_{j(TH)}$	$I_O = 5\text{ mA}$	—	150	—	°C

### ■ Electrical Characteristics at $T_a = 25^\circ\text{C}$ (continued)

#### • AN7806NSP (6 V type)

The specified condition  $T_j = 25^\circ\text{C}$  means that the test should be carried out within so short a test time (within 10 ms) that the characteristic value drift due to the chip junction temperature rise can be ignored.

Unless otherwise specified,  $V_I = 11\text{ V}$ ,  $I_O = 500\text{ mA}$ ,  $C_I = 0.33\text{ }\mu\text{F}$  and  $C_O = 0.1\text{ }\mu\text{F}$

Parameter	Symbol	Conditions	Min	Typ	Max	Unit
Output voltage	$V_{O1}$	$T_j = 25^\circ\text{C}$	5.75	6	6.25	V
Output voltage tolerance	$V_{O2}$	$V_I = 9\text{ V to } 21\text{ V}$ , $I_O = 5\text{ mA to } 1\text{ A}$ $T_j = 25^\circ\text{C}$ , $P_D < 5\text{ W}$	5.7	—	6.3	V
Line regulation 1	$\text{REG}_{\text{IN}1}$	$V_I = 8.5\text{ V to } 25\text{ V}$ , $T_j = 25^\circ\text{C}$	—	5	120	mV
Line regulation 2	$\text{REG}_{\text{IN}2}$	$V_I = 9\text{ V to } 13\text{ V}$ , $T_j = 25^\circ\text{C}$	—	1.5	60	mV
Load regulation 1	$\text{REG}_{\text{L}1}$	$I_O = 5\text{ mA to } 1.5\text{ A}$ , $T_j = 25^\circ\text{C}$	—	14	120	mV
Load regulation 2	$\text{REG}_{\text{L}2}$	$I_O = 250\text{ mA to } 750\text{ mA}$ , $T_j = 25^\circ\text{C}$	—	4.0	60	mV
Bias current	$I_{\text{Bias}}$	$T_j = 25^\circ\text{C}$	—	3.9	8	mA
Bias current fluctuation to input	$\Delta I_{\text{Bias}(\text{IN})}$	$V_I = 8.5\text{ V to } 25\text{ V}$ , $T_j = 25^\circ\text{C}$	—	—	1.3	mA
Bias current fluctuation to load	$\Delta I_{\text{Bias}(\text{L})}$	$I_O = 5\text{ mA to } 1\text{ A}$ , $T_j = 25^\circ\text{C}$	—	—	0.5	mA
Ripple rejection ratio	RR	$V_I = 9\text{ V to } 19\text{ V}$ , $I_O = 100\text{ mA}$ , $f = 120\text{ Hz}$	59	—	—	dB

#### • Design reference data

Note) The characteristics listed below are theoretical values based on the IC design and are not guaranteed.

Parameter	Symbol	Conditions	Min	Typ	Max	Unit
Output noise voltage	$V_{\text{NO}}$	$f = 10\text{ Hz to } 100\text{ kHz}$	—	40	—	$\mu\text{V}$
Minimum input/output voltage difference	$V_{\text{DIF}(\text{min})}$	$I_O = 1\text{ A}$ , $T_j = 25^\circ\text{C}$	—	2	—	V
Output short-circuit current	$I_{\text{O}(\text{Short})}$	$V_I = 35\text{ V}$ , $T_j = 25^\circ\text{C}$	—	700	—	mA
Peak output current	$I_{\text{O}(\text{Peak})}$	$T_j = 25^\circ\text{C}$	—	2.0	—	A
Output voltage temperature coefficient	$\Delta V_O / T_a$	$I_O = 5\text{ mA}$ , $T_j = 0^\circ\text{C to } 125^\circ\text{C}$	—	-0.4	—	$\text{mV}/^\circ\text{C}$
Thermal protection operating temperature	$T_{\text{j}(\text{TH})}$	$I_O = 5\text{ mA}$	—	150	—	$^\circ\text{C}$

### ■ Electrical Characteristics at $T_a = 25^\circ\text{C}$ (continued)

#### • AN7807NSP (7 V type)

The specified condition  $T_j = 25^\circ\text{C}$  means that the test should be carried out within so short a test time (within 10 ms) that the characteristic value drift due to the chip junction temperature rise can be ignored.

Unless otherwise specified,  $V_I = 12\text{ V}$ ,  $I_O = 500\text{ mA}$ ,  $C_I = 0.33\text{ }\mu\text{F}$  and  $C_O = 0.1\text{ }\mu\text{F}$

Parameter	Symbol	Conditions	Min	Typ	Max	Unit
Output voltage	$V_{O1}$	$T_j = 25^\circ\text{C}$	6.7	7	7.3	V
Output voltage tolerance	$V_{O2}$	$V_I = 10\text{ V to }22\text{ V}$ , $I_O = 5\text{ mA to }1\text{ A}$ $T_j = 25^\circ\text{C}$ , $P_D < 5\text{ W}$	6.6	—	7.4	V
Line regulation 1	$\text{REG}_{\text{IN}1}$	$V_I = 9.5\text{ V to }25\text{ V}$ , $T_j = 25^\circ\text{C}$	—	5	140	mV
Line regulation 2	$\text{REG}_{\text{IN}2}$	$V_I = 10\text{ V to }15\text{ V}$ , $T_j = 25^\circ\text{C}$	—	1.5	70	mV
Load regulation 1	$\text{REG}_{\text{L}1}$	$I_O = 5\text{ mA to }1.5\text{ A}$ , $T_j = 25^\circ\text{C}$	—	14	140	mV
Load regulation 2	$\text{REG}_{\text{L}2}$	$I_O = 250\text{ mA to }750\text{ mA}$ , $T_j = 25^\circ\text{C}$	—	4.0	70	mV
Bias current	$I_{\text{Bias}}$	$T_j = 25^\circ\text{C}$	—	3.9	8	mA
Bias current fluctuation to input	$\Delta I_{\text{Bias}(\text{IN})}$	$V_I = 9.5\text{ V to }25\text{ V}$ , $T_j = 25^\circ\text{C}$	—	—	1.0	mA
Bias current fluctuation to load	$\Delta I_{\text{Bias}(\text{L})}$	$I_O = 5\text{ mA to }1\text{ A}$ , $T_j = 25^\circ\text{C}$	—	—	0.5	mA
Ripple rejection ratio	RR	$V_I = 10\text{ V to }20\text{ V}$ , $I_O = 100\text{ mA}$ , $f = 120\text{ Hz}$	57	—	—	dB

#### • Design reference data

Note) The characteristics listed below are theoretical values based on the IC design and are not guaranteed.

Parameter	Symbol	Conditions	Min	Typ	Max	Unit
Output noise voltage	$V_{\text{NO}}$	$f = 10\text{ Hz to }100\text{ kHz}$	—	46	—	$\mu\text{V}$
Minimum input/output voltage difference	$V_{\text{DIF}(\text{min})}$	$I_O = 1\text{ A}$ , $T_j = 25^\circ\text{C}$	—	2	—	V
Output short-circuit current	$I_{\text{O}(\text{Short})}$	$V_I = 35\text{ V}$ , $T_j = 25^\circ\text{C}$	—	700	—	mA
Peak output current	$I_{\text{O}(\text{Peak})}$	$T_j = 25^\circ\text{C}$	—	2.0	—	A
Output voltage temperature coefficient	$\Delta V_O / T_a$	$I_O = 5\text{ mA}$ , $T_j = 0^\circ\text{C to }125^\circ\text{C}$	—	-0.5	—	$\text{mV}/^\circ\text{C}$
Thermal protection operating temperature	$T_{\text{j}(\text{TH})}$	$I_O = 5\text{ mA}$	—	150	—	$^\circ\text{C}$

■ Electrical Characteristics at  $T_a = 25^\circ\text{C}$  (continued)

• AN7808NSP (8 V type)

The specified condition  $T_j = 25^\circ\text{C}$  means that the test should be carried out within so short a test time (within 10 ms) that the characteristic value drift due to the chip junction temperature rise can be ignored.

Unless otherwise specified,  $V_I = 14\text{ V}$ ,  $I_O = 500\text{ mA}$ ,  $C_I = 0.33\text{ }\mu\text{F}$  and  $C_O = 0.1\text{ }\mu\text{F}$

Parameter	Symbol	Conditions	Min	Typ	Max	Unit
Output voltage	$V_{O1}$	$T_j = 25^\circ\text{C}$	7.7	8	8.3	V
Output voltage tolerance	$V_{O2}$	$V_I = 11\text{ V to }23\text{ V}$ , $I_O = 5\text{ mA to }1\text{ A}$ $T_j = 25^\circ\text{C}$ , $P_D < 5\text{ W}$	7.6	—	8.4	V
Line regulation 1	$\text{REG}_{\text{IN}1}$	$V_I = 10.5\text{ V to }25\text{ V}$ , $T_j = 25^\circ\text{C}$	—	6	160	mV
Line regulation 2	$\text{REG}_{\text{IN}2}$	$V_I = 11\text{ V to }17\text{ V}$ , $T_j = 25^\circ\text{C}$	—	2	80	mV
Load regulation 1	$\text{REG}_{\text{L}1}$	$I_O = 5\text{ mA to }1.5\text{ A}$ , $T_j = 25^\circ\text{C}$	—	12	160	mV
Load regulation 2	$\text{REG}_{\text{L}2}$	$I_O = 250\text{ mA to }750\text{ mA}$ , $T_j = 25^\circ\text{C}$	—	4.0	80	mV
Bias current	$I_{\text{Bias}}$	$T_j = 25^\circ\text{C}$	—	3.9	8	mA
Bias current fluctuation to input	$\Delta I_{\text{Bias}(\text{IN})}$	$V_I = 10.5\text{ V to }25\text{ V}$ , $T_j = 25^\circ\text{C}$	—	—	1.0	mA
Bias current fluctuation to load	$\Delta I_{\text{Bias}(\text{L})}$	$I_O = 5\text{ mA to }1\text{ A}$ , $T_j = 25^\circ\text{C}$	—	—	0.5	mA
Ripple rejection ratio	RR	$V_I = 11.5\text{ V to }21.5\text{ V}$ , $I_O = 100\text{ mA}$ , $f = 120\text{ Hz}$	56	—	—	dB

• Design reference data

Note) The characteristics listed below are theoretical values based on the IC design and are not guaranteed.

Parameter	Symbol	Conditions	Min	Typ	Max	Unit
Output noise voltage	$V_{\text{NO}}$	$f = 10\text{ Hz to }100\text{ kHz}$	—	52	—	$\mu\text{V}$
Minimum input/output voltage difference	$V_{\text{DIF}(\text{min})}$	$I_O = 1\text{ A}$ , $T_j = 25^\circ\text{C}$	—	2	—	V
Output short-circuit current	$I_{\text{O}(\text{Short})}$	$V_I = 35\text{ V}$ , $T_j = 25^\circ\text{C}$	—	700	—	mA
Peak output current	$I_{\text{O}(\text{Peak})}$	$T_j = 25^\circ\text{C}$	—	2.0	—	A
Output voltage temperature coefficient	$\Delta V_O / T_a$	$I_O = 5\text{ mA}$ , $T_j = 0^\circ\text{C to }125^\circ\text{C}$	—	-0.5	—	$\text{mV}/^\circ\text{C}$
Thermal protection operating temperature	$T_{j(\text{TH})}$	$I_O = 5\text{ mA}$	—	150	—	$^\circ\text{C}$

■ Electrical Characteristics at  $T_a = 25^\circ\text{C}$  (continued)

• AN7809NSP (9 V type)

The specified condition  $T_j = 25^\circ\text{C}$  means that the test should be carried out within so short a test time (within 10 ms) that the characteristic value drift due to the chip junction temperature rise can be ignored.

Unless otherwise specified,  $V_I = 15\text{ V}$ ,  $I_O = 500\text{ mA}$ ,  $C_I = 0.33\text{ }\mu\text{F}$  and  $C_O = 0.1\text{ }\mu\text{F}$

Parameter	Symbol	Conditions	Min	Typ	Max	Unit
Output voltage	$V_{O1}$	$T_j = 25^\circ\text{C}$	8.65	9	9.35	V
Output voltage tolerance	$V_{O2}$	$V_I = 12\text{ V to }24\text{ V}$ , $I_O = 5\text{ mA to }1\text{ A}$ $T_j = 25^\circ\text{C}$ , $P_D < 5\text{ W}$	8.55	—	9.45	V
Line regulation 1	$\text{REG}_{\text{IN}1}$	$V_I = 11.5\text{ V to }26\text{ V}$ , $T_j = 25^\circ\text{C}$	—	7	180	mV
Line regulation 2	$\text{REG}_{\text{IN}2}$	$V_I = 12\text{ V to }18\text{ V}$ , $T_j = 25^\circ\text{C}$	—	2	90	mV
Load regulation 1	$\text{REG}_{\text{L}1}$	$I_O = 5\text{ mA to }1.5\text{ A}$ , $T_j = 25^\circ\text{C}$	—	12	180	mV
Load regulation 2	$\text{REG}_{\text{L}2}$	$I_O = 250\text{ mA to }750\text{ mA}$ , $T_j = 25^\circ\text{C}$	—	4.0	90	mV
Bias current	$I_{\text{Bias}}$	$T_j = 25^\circ\text{C}$	—	3.9	8	mA
Bias current fluctuation to input	$\Delta I_{\text{Bias}(\text{IN})}$	$V_I = 11.5\text{ V to }26\text{ V}$ , $T_j = 25^\circ\text{C}$	—	—	1.0	mA
Bias current fluctuation to load	$\Delta I_{\text{Bias}(\text{L})}$	$I_O = 5\text{ mA to }1\text{ A}$ , $T_j = 25^\circ\text{C}$	—	—	0.5	mA
Ripple rejection ratio	RR	$V_I = 11.5\text{ V to }21.5\text{ V}$ , $I_O = 100\text{ mA}$ , $f = 120\text{ Hz}$	56	—	—	dB

• Design reference data

Note) The characteristics listed below are theoretical values based on the IC design and are not guaranteed.

Parameter	Symbol	Conditions	Min	Typ	Max	Unit
Output noise voltage	$V_{\text{NO}}$	$f = 10\text{ Hz to }100\text{ kHz}$	—	57	—	$\mu\text{V}$
Minimum input/output voltage difference	$V_{\text{DIF}(\text{min})}$	$I_O = 1\text{ A}$ , $T_j = 25^\circ\text{C}$	—	2	—	V
output short-circuit current	$I_{\text{O}(\text{Short})}$	$V_I = 35\text{ V}$ , $T_j = 25^\circ\text{C}$	—	700	—	mA
Peak output current	$I_{\text{O}(\text{Peak})}$	$T_j = 25^\circ\text{C}$	—	2.0	—	A
Output voltage temperature coefficient	$\Delta V_O / T_a$	$I_O = 5\text{ mA}$ , $T_j = 0^\circ\text{C to }125^\circ\text{C}$	—	-0.5	—	$\text{mV}/^\circ\text{C}$
Thermal protection operating temperature	$T_{\text{j}(\text{TH})}$	$I_O = 5\text{ mA}$	—	150	—	$^\circ\text{C}$

### ■ Electrical Characteristics at $T_a = 25^\circ\text{C}$ (continued)

#### • AN7810NSP (10 V type)

The specified condition  $T_j = 25^\circ\text{C}$  means that the test should be carried out within so short a test time (within 10 ms) that the characteristic value drift due to the chip junction temperature rise can be ignored.

Unless otherwise specified,  $V_I = 16\text{ V}$ ,  $I_O = 500\text{ mA}$ ,  $C_I = 0.33\text{ }\mu\text{F}$  and  $C_O = 0.1\text{ }\mu\text{F}$

Parameter	Symbol	Conditions	Min	Typ	Max	Unit
Output voltage	$V_{O1}$	$T_j = 25^\circ\text{C}$	9.6	10	10.4	V
Output voltage tolerance	$V_{O2}$	$V_I = 13\text{ V to }25\text{ V}$ , $I_O = 5\text{ mA to }1\text{ A}$ $T_j = 25^\circ\text{C}$ , $P_D < 5\text{ W}$	9.5	—	10.5	V
Line regulation 1	$\text{REG}_{\text{IN}1}$	$V_I = 12.5\text{ V to }27\text{ V}$ , $T_j = 25^\circ\text{C}$	—	8	200	mV
Line regulation 2	$\text{REG}_{\text{IN}2}$	$V_I = 13\text{ V to }19\text{ V}$ , $T_j = 25^\circ\text{C}$	—	2.5	100	mV
Load regulation 1	$\text{REG}_{\text{L}1}$	$I_O = 5\text{ mA to }1.5\text{ A}$ , $T_j = 25^\circ\text{C}$	—	12	200	mV
Load regulation 2	$\text{REG}_{\text{L}2}$	$I_O = 250\text{ mA to }750\text{ mA}$ , $T_j = 25^\circ\text{C}$	—	4.0	100	mV
Bias current	$I_{\text{Bias}}$	$T_j = 25^\circ\text{C}$	—	3.9	8	mA
Bias current fluctuation to input	$\Delta I_{\text{Bias}(\text{IN})}$	$V_I = 12.5\text{ V to }27\text{ V}$ , $T_j = 25^\circ\text{C}$	—	—	1.0	mA
Bias current fluctuation to load	$\Delta I_{\text{Bias}(\text{L})}$	$I_O = 5\text{ mA to }1\text{ A}$ , $T_j = 25^\circ\text{C}$	—	—	0.5	mA
Ripple rejection ratio	RR	$V_I = 13\text{ V to }23\text{ V}$ , $I_O = 100\text{ mA}$ , $f = 120\text{ Hz}$	56	—	—	dB

#### • Design reference data

Note) The characteristics listed below are theoretical values based on the IC design and are not guaranteed.

Parameter	Symbol	Conditions	Min	Typ	Max	Unit
Output noise voltage	$V_{\text{NO}}$	$f = 10\text{ Hz to }100\text{ kHz}$	—	56	—	$\mu\text{V}$
Minimum input/output voltage difference	$V_{\text{DIF}(\text{min})}$	$I_O = 1\text{ A}$ , $T_j = 25^\circ\text{C}$	—	2	—	V
Output short-circuit current	$I_{\text{O}(\text{Short})}$	$V_I = 35\text{ V}$ , $T_j = 25^\circ\text{C}$	—	700	—	mA
Peak output current	$I_{\text{O}(\text{Peak})}$	$T_j = 25^\circ\text{C}$	—	2.0	—	A
Output voltage temperature coefficient	$\Delta V_O / T_a$	$I_O = 5\text{ mA}$ , $T_j = 0^\circ\text{C to }125^\circ\text{C}$	—	-0.6	—	$\text{mV}/^\circ\text{C}$
Thermal protection operating temperature	$T_{\text{j}(\text{TH})}$	$I_O = 5\text{ mA}$	—	150	—	$^\circ\text{C}$

### ■ Electrical Characteristics at $T_a = 25^\circ\text{C}$ (continued)

#### • AN7812NSP (12 V type)

The specified condition  $T_j = 25^\circ\text{C}$  means that the test should be carried out within so short a test time (within 10 ms) that the characteristic value drift due to the chip junction temperature rise can be ignored.

Unless otherwise specified,  $V_I = 19\text{ V}$ ,  $I_O = 500\text{ mA}$ ,  $C_1 = 0.33\text{ }\mu\text{F}$  and  $C_O = 0.1\text{ }\mu\text{F}$

Parameter	Symbol	Conditions	Min	Typ	Max	Unit
Output voltage	$V_{O1}$	$T_j = 25^\circ\text{C}$	11.5	12	12.5	V
Output voltage tolerance	$V_{O2}$	$V_I = 15\text{ V to }27\text{ V}$ , $I_O = 5\text{ mA to }1\text{ A}$ $T_j = 25^\circ\text{C}$ , $P_D < 5\text{ W}$	11.4	—	12.6	V
Line regulation 1	$\text{REG}_{\text{IN}1}$	$V_I = 14.5\text{ V to }30\text{ V}$ , $T_j = 25^\circ\text{C}$	—	10	240	mV
Line regulation 2	$\text{REG}_{\text{IN}2}$	$V_I = 16\text{ V to }22\text{ V}$ , $T_j = 25^\circ\text{C}$	—	2	120	mV
Load regulation 1	$\text{REG}_{\text{L}1}$	$I_O = 5\text{ mA to }1.5\text{ A}$ , $T_j = 25^\circ\text{C}$	—	12	240	mV
Load regulation 2	$\text{REG}_{\text{L}2}$	$I_O = 250\text{ mA to }750\text{ mA}$ , $T_j = 25^\circ\text{C}$	—	4.0	120	mV
Bias current	$I_{\text{Bias}}$	$T_j = 25^\circ\text{C}$	—	4.0	8	mA
Bias current fluctuation to input	$\Delta I_{\text{Bias}(\text{IN})}$	$V_I = 14.5\text{ V to }30\text{ V}$ , $T_j = 25^\circ\text{C}$	—	—	1.0	mA
Bias current fluctuation to load	$\Delta I_{\text{Bias}(\text{L})}$	$I_O = 5\text{ mA to }1\text{ A}$ , $T_j = 25^\circ\text{C}$	—	—	0.5	mA
Ripple rejection ratio	RR	$V_I = 15\text{ V to }25\text{ V}$ , $I_O = 100\text{ mA}$ , $f = 120\text{ Hz}$	55	—	—	dB

#### • Design reference data

Note) The characteristics listed below are theoretical values based on the IC design and are not guaranteed.

Parameter	Symbol	Conditions	Min	Typ	Max	Unit
Output noise voltage	$V_{\text{NO}}$	$f = 10\text{ Hz to }100\text{ kHz}$	—	75	—	$\mu\text{V}$
Minimum input/output voltage difference	$V_{\text{DIF}(\text{min})}$	$I_O = 1\text{ A}$ , $T_j = 25^\circ\text{C}$	—	2	—	V
Output short-circuit current	$I_{\text{O}(\text{Short})}$	$V_I = 35\text{ V}$ , $T_j = 25^\circ\text{C}$	—	700	—	mA
Peak output current	$I_{\text{O}(\text{Peak})}$	$T_j = 25^\circ\text{C}$	—	2.0	—	A
Output voltage temperature coefficient	$\Delta V_O / T_a$	$I_O = 5\text{ mA}$ , $T_j = 0^\circ\text{C to }125^\circ\text{C}$	—	-0.8	—	$\text{mV}/^\circ\text{C}$
Thermal protection operating temperature	$T_{\text{j}(\text{TH})}$	$I_O = 5\text{ mA}$	—	150	—	$^\circ\text{C}$



### ■ Electrical Characteristics at $T_a = 25^\circ\text{C}$ (continued)

#### • AN7815NSP (15 V type)

The specified condition  $T_j = 25^\circ\text{C}$  means that the test should be carried out within so short a test time (within 10 ms) that the characteristic value drift due to the chip junction temperature rise can be ignored.

Unless otherwise specified,  $V_I = 23\text{ V}$ ,  $I_O = 500\text{ mA}$ ,  $C_I = 0.33\text{ }\mu\text{F}$  and  $C_O = 0.1\text{ }\mu\text{F}$

Parameter	Symbol	Conditions	Min	Typ	Max	Unit
Output voltage	$V_{O1}$	$T_j = 25^\circ\text{C}$	14.4	15	15.6	V
Output voltage tolerance	$V_{O2}$	$V_I = 18\text{ V to }30\text{ V}$ , $I_O = 5\text{ mA to }1\text{ A}$ $T_j = 25^\circ\text{C}$ , $P_D < 5\text{ W}$	14.25	—	15.75	V
Line regulation 1	$\text{REG}_{\text{IN}1}$	$V_I = 17.5\text{ V to }30\text{ V}$ , $T_j = 25^\circ\text{C}$	—	11	300	mV
Line regulation 2	$\text{REG}_{\text{IN}2}$	$V_I = 20\text{ V to }26\text{ V}$ , $T_j = 25^\circ\text{C}$	—	3	150	mV
Load regulation 1	$\text{REG}_{\text{L}1}$	$I_O = 5\text{ mA to }1.5\text{ A}$ , $T_j = 25^\circ\text{C}$	—	12	300	mV
Load regulation 2	$\text{REG}_{\text{L}2}$	$I_O = 250\text{ mA to }750\text{ mA}$ , $T_j = 25^\circ\text{C}$	—	4.0	150	mV
Bias current	$I_{\text{Bias}}$	$T_j = 25^\circ\text{C}$	—	4.0	8	mA
Bias current fluctuation to input	$\Delta I_{\text{Bias}(\text{IN})}$	$V_I = 17.5\text{ V to }30\text{ V}$ , $T_j = 25^\circ\text{C}$	—	—	1.0	mA
Bias current fluctuation to load	$\Delta I_{\text{Bias}(\text{L})}$	$I_O = 5\text{ mA to }1\text{ A}$ , $T_j = 25^\circ\text{C}$	—	—	0.5	mA
Ripple rejection ratio	RR	$V_I = 18.5\text{ V to }28.5\text{ V}$ , $I_O = 100\text{ mA}$ , $f = 120\text{ Hz}$	54	—	—	dB

#### • Design reference data

Note) The characteristics listed below are theoretical values based on the IC design and are not guaranteed.

Parameter	Symbol	Conditions	Min	Typ	Max	Unit
Output noise voltage	$V_{\text{NO}}$	$f = 10\text{ Hz to }100\text{ kHz}$	—	90	—	$\mu\text{V}$
Minimum input/output voltage difference	$V_{\text{DIF}(\text{min})}$	$I_O = 1\text{ A}$ , $T_j = 25^\circ\text{C}$	—	2	—	V
Output short-circuit current	$I_{\text{O}(\text{Short})}$	$V_I = 35\text{ V}$ , $T_j = 25^\circ\text{C}$	—	700	—	mA
Peak output current	$I_{\text{O}(\text{Peak})}$	$T_j = 25^\circ\text{C}$	—	2.0	—	A
Output voltage temperature coefficient	$\Delta V_O / T_a$	$I_O = 5\text{ mA}$ , $T_j = 0^\circ\text{C to }125^\circ\text{C}$	—	-1.0	—	$\text{mV}/^\circ\text{C}$
Thermal protection operating temperature	$T_{\text{j}(\text{TH})}$	$I_O = 5\text{ mA}$	—	150	—	$^\circ\text{C}$

### ■ Electrical Characteristics at $T_a = 25^\circ\text{C}$ (continued)

#### • AN7818NSP (18 V type)

The specified condition  $T_j = 25^\circ\text{C}$  means that the test should be carried out within so short a test time (within 10 ms) that the characteristic value drift due to the chip junction temperature rise can be ignored.

Unless otherwise specified,  $V_I = 27\text{ V}$ ,  $I_O = 500\text{ mA}$ ,  $C_I = 0.33\text{ }\mu\text{F}$  and  $C_O = 0.1\text{ }\mu\text{F}$

Parameter	Symbol	Conditions	Min	Typ	Max	Unit
Output voltage	$V_{O1}$	$T_j = 25^\circ\text{C}$	17.3	18	18.7	V
Output voltage tolerance	$V_{O2}$	$V_I = 21\text{ V to }33\text{ V}$ , $I_O = 5\text{ mA to }1\text{ A}$ $T_j = 25^\circ\text{C}$ , $P_D < 5\text{ W}$	17.1	—	18.9	V
Line regulation 1	$\text{REG}_{\text{IN}1}$	$V_I = 21\text{ V to }33\text{ V}$ , $T_j = 25^\circ\text{C}$	—	14	360	mV
Line regulation 2	$\text{REG}_{\text{IN}2}$	$V_I = 24\text{ V to }30\text{ V}$ , $T_j = 25^\circ\text{C}$	—	4	180	mV
Load regulation 1	$\text{REG}_{\text{L}1}$	$I_O = 5\text{ mA to }1.5\text{ A}$ , $T_j = 25^\circ\text{C}$	—	14	360	mV
Load regulation 2	$\text{REG}_{\text{L}2}$	$I_O = 250\text{ mA to }750\text{ mA}$ , $T_j = 25^\circ\text{C}$	—	4.0	180	mV
Bias current	$I_{\text{Bias}}$	$T_j = 25^\circ\text{C}$	—	4.1	8	mA
Bias current fluctuation to input	$\Delta I_{\text{Bias}(\text{IN})}$	$V_I = 21\text{ V to }33\text{ V}$ , $T_j = 25^\circ\text{C}$	—	—	1.0	mA
Bias current fluctuation to load	$\Delta I_{\text{Bias}(\text{L})}$	$I_O = 5\text{ mA to }1\text{ A}$ , $T_j = 25^\circ\text{C}$	—	—	0.5	mA
Ripple rejection ratio	RR	$V_I = 22\text{ V to }32\text{ V}$ , $I_O = 100\text{ mA}$ , $f = 120\text{ Hz}$	53	—	—	dB

#### • Design reference data

Note) The characteristics listed below are theoretical values based on the IC design and are not guaranteed.

Parameter	Symbol	Conditions	Min	Typ	Max	Unit
Output noise voltage	$V_{\text{NO}}$	$f = 10\text{ Hz to }100\text{ kHz}$	—	110	—	$\mu\text{V}$
Minimum input/output voltage difference	$V_{\text{DIF}(\text{min})}$	$I_O = 1\text{ A}$ , $T_j = 25^\circ\text{C}$	—	2	—	V
Output short-circuit current	$I_{\text{O}(\text{Short})}$	$V_I = 35\text{ V}$ , $T_j = 25^\circ\text{C}$	—	700	—	mA
Peak output current	$I_{\text{O}(\text{Peak})}$	$T_j = 25^\circ\text{C}$	—	2.0	—	A
Output voltage temperature coefficient	$\Delta V_O / T_a$	$I_O = 5\text{ mA}$ , $T_j = 0^\circ\text{C to }125^\circ\text{C}$	—	-1.1	—	$\text{mV}/^\circ\text{C}$
Thermal protection operating temperature	$T_{\text{j}(\text{TH})}$	$I_O = 5\text{ mA}$	—	150	—	$^\circ\text{C}$

■ Application Notes

1.  $P_D - T_a$  curves of SP-3SU

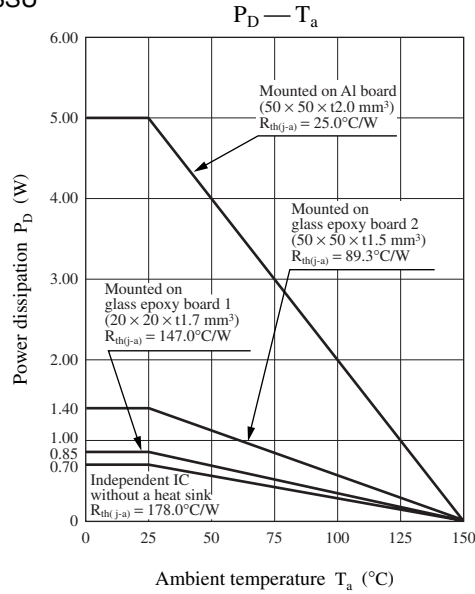

2. Main Characteristics

Minimum input/output voltage difference vs. load current characteristic

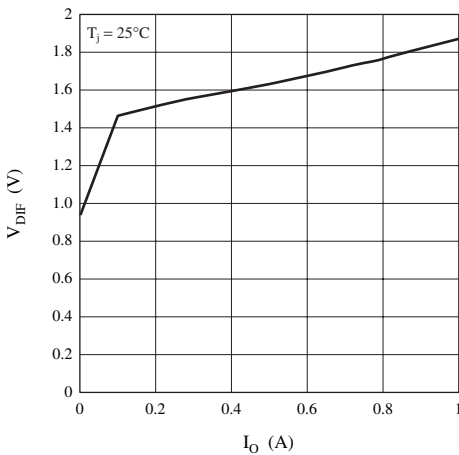

Minimum input/output voltage difference temperature characteristic

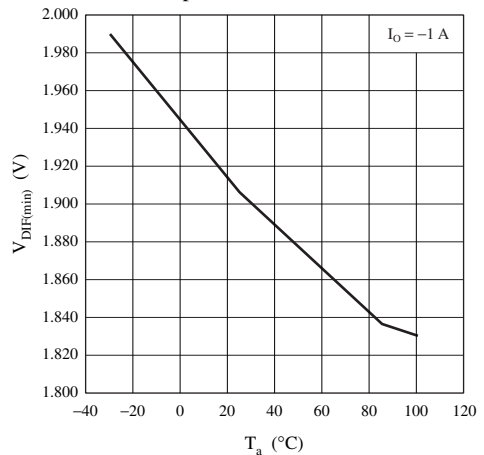

Peak output current temperature characteristic

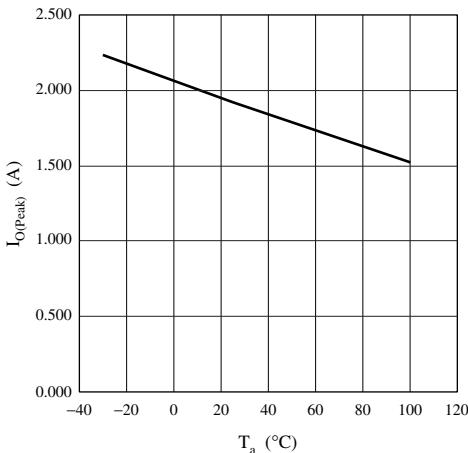

Current limit characteristics

