

DATA DISPLAY AG

LM151X3-B3 PANELLINK 15.1" XGA TFT LCD

PRELIMINARY SPECIFICATION

The information given in this document is carefully checked and believed to be reliable. Data Display reserves the right to make changes in product or specification at any time and without further notice. Data Display products are not intended for use in systems in which failures of product could result in personal injury. All mentioned trademarks are registered trademarks of their owner.

LG.Philips LCD: Rev. 1.1, June 27, 2000



1. GENERAL DESCRIPTION

The LM151X3-B3AP is a Color Active Matrix Liquid Crystal Display with an integral Cold Cathode Fluorescent Lamp (CCFL) backlight system. The matrix employs a-Si Thin Film Transistor as the active element. It is a transmissive type display operating in the normally white mode. This TFT-LCD has a 15.1 inches diagonally measured active display area with XGA resolution (768 vertical by 1024 horizontal pixel array). Each pixel is divided into Red, Green and Blue sub-pixels or dots which are arranged in vertical stripes. Gray scale or the brightness of the sub-pixel color is determined with a 8-bit gray scale signal for each dot, thus, presenting a palette of more than 16,777,216 colors.

The LM151X3-B3AP has been designed to apply the TMDS interface method. The LM151X3-B3AP LCD is intended to support applications where high brightness, wide viewing angle, high color saturation, and high color depth are very important. In combination with the vertical arrangement of the sub-pixels, **the LM151X3-B3 characteristics provide an excellent flat panel display for office automation products such as monitors, Kiosk-Terminals or Point-of-Information terminals.**

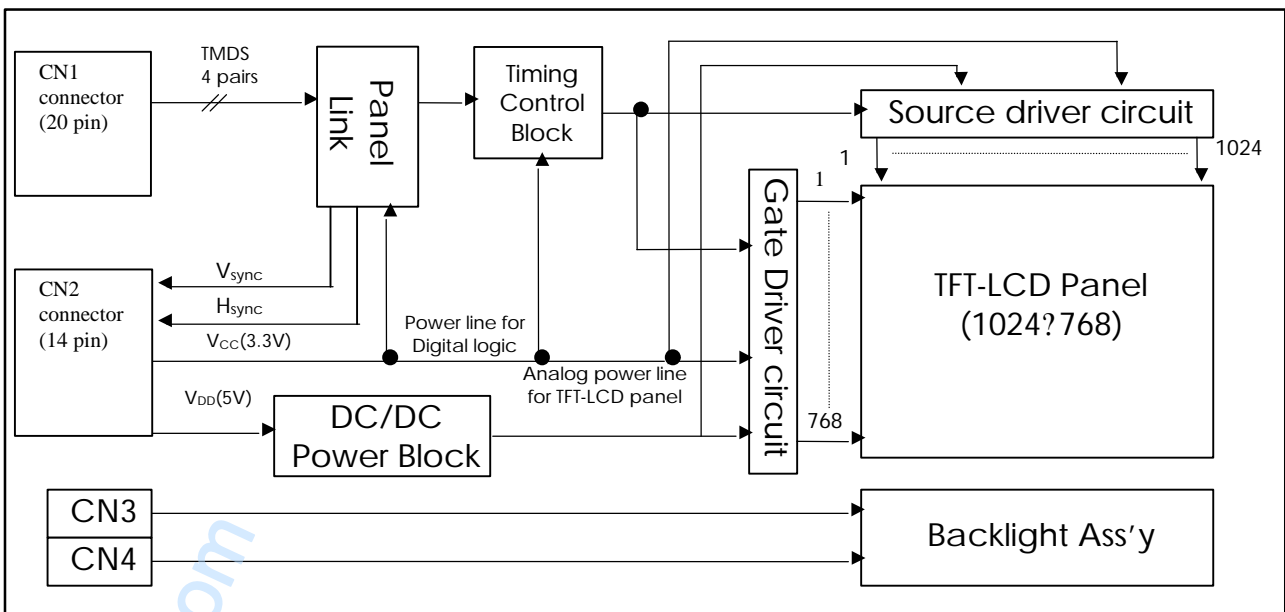

General Features

Active screen size	15.1 inches (307.2 x 230.4mm) diagonal
Outline dimensions	352.0(H) x 263.5(V) x 16.0(D) mm (typ) without user connector
Pixel pitch	0.300 mm x 0.300 mm
Pixel format	1024 horiz. By 768 vert. pixels
Color depth	8-bit, 16,777,216 colors
Luminance, White	250 cd/m ² (typ)
Power Consumption	2.1 Watts Logic / 9.7Watts CCFL (typ. With 256 Gray Pattern)
Weight	1500g (typ)
Display operating mode	Transmissive mode, normally white
Surface treatments	Hard coating(3H), Anti-glare treatment of the front polarizer



2. ABSOLUTE MAXIMUM RATINGS

The following are maximum values which, if exceeded, may cause faulty operation or damage to the unit.

Table 1 ABSOLUTE MAXIMUM RATINGS

Parameter	Symbol	Values		Units	Notes
		Min.	Max.		
Power Input Voltage	V_{CC}	-0.5	+3.6	Vdc	at 25°
	V_{dd}	-0.5	+5.8	Vdc	
Operating Temperature	T_{OP}	0	+50*	°C	1,2
Storage Temperature	T_{ST}	-20	+60	°C	1,2

Note 1: Temperature at 5mm above display center of LCD Module.

$T_a = 40^\circ$: 90%RH Max.

These shall be no dew condensation.

Note 2: Humidity Min. 5%RH, Max. 90%RH

* Optical values (contrast, response time, brightness, viewing angle) maybe influenced in lower and upper T_{OP}



3. ELECTRICAL SPECIFICATIONS

3.1 Electrical Characteristics

The LM151X3-B3AP requires two power inputs. One is employed to power the LCD electronics and to drive the TFT array and liquid crystal. The second input which powers the CCFL, is typically generated by an inverter. The inverter is an external unit to the LCD.

Table 2 ELECTRICAL CHARACTERISTICS:

Parameter	Symbol	Values			Units	Notes
		Min.	Typ.	Max.		
MODULE:						
Power Supply Input Voltage	V_{CC}	3.15	3.3	3.45	Vdc	
	V_{DD}	4.5	5.0	5.5	Vdc	
Power Supply Input Current	I_{CC}	0.20	0.23	0.26	A	1
	I_{DD}	0.20	0.25	0.30	A	
Power Consumption	P_c	-	2.1	3.0	Watts	1
LAMP						
Operating Voltage	V_{BL}	585(9mA)	605(8mA)	720(3mA)	V_{RMS}	2
Operating Current	I_{BL}	3.0	8.0	9.0	mA	
Established Starting Voltage	V_{BS}					3
at 25°		-	-	1020	V_{RMS}	
at 0°		-	-	1430	V_{RMS}	
Operating Frequency	f_{BL}	30	50	60	KHz	4
Discharge Stabilization Time	T_s	-	-	3	Minutes	5
Power Consumption	P_{BL}	-	9.7	10.6	Watts	6
Half Life Time		30000	-	-	Hrs	7

Notes 1: The specified current and power consumption are under the $V_{DD} = 5.0V$, $V_{CC} = 3.3V$, 25° and $f_v = 60Hz$ condition Power supply input current and Typ. Power consumption is measured while 256 gray pattern is displayed. The max. power consumption is measured while Vertical 2line (full white) by 2line(full black) pattern is displayed.

Notes 2: The variance of the voltage is $\pm 10\%$.

Notes 3: The voltage above V_s should be applied to the lamps for more than 1second for start-up. Otherwise, the lamps may not be turned on.

Notes 4: The output of the inverter must have symmetrical (negative and positive) voltage waveform and symmetrical current waveform. (Unsymmetrical ratio is less than 10%). Please do not use the inverter which has unsymmetrical voltage and unsymmetrical current and spike wave. Lamp frequency may produce interference with horizontal synchronous frequency and as a result this may cause beat on the display. Therefore lamp frequency shall be as away as



possible from the horizontal synchronous frequency and from its harmonics in order to prevent interference.

Notes 5: The brightness of the lamp after being lighted for 5 minutes is defined as 100%. This is the time required for the brightness of the center of the lamp to be not less than 95%.

Notes 6: The lamp power consumption shown above does not include loss of external inverter.

Notes 7: The life time is determined as the time at which brightness of lamp is 50% compared to that of initial value at the typical lamp current on condition of continuous operating at $25 \pm 2^\circ$.

3.2 Interface Connections

This LCM has four interface connections, a 20 pin connector and a 14 pin connector are used for the module electronics and, two three pin connectors are used for the integral backlight system.

The electronics interface connector is a model DF19K-20P-1H (20 Pin connector) and the other model DF19L-14P-1H (14 Pin connector) manufactured by Hirose. The pin configuration for the connector is shown in the table below. (LCD Connector: DF19K-20P-1H and DF19L-14P-1H, Mating Connector: DF19G-20S-1C and DF19G-14S-1C.)

Table 3 MODULE CONNECTOR PIN CONFIGURATION

Pin	Symbol	I/O	Description	Pin	Symbol	I/O	Description
1	GND	INPUT	Ground	1	GND	INPUT	Ground
2	GND	INPUT	Ground	2	Vsync.	OUTPUT	Vsync.
3	Rx2+	INPUT	Plus Red TMDS signal	3	Hsync.	OUTPUT	Hsync.
4	Rx2-	INPUT	Minus Red TMDS signal	4	GND	INPUT	Ground
5	GND	INPUT	Ground	5			NC
6	Rx1+	INPUT	Plus Green TMDS signal	6			NC
7	Rx1-	INPUT	Minus Green TMDS signal	7			NC
8	GND	INPUT	Ground	8	GND	INPUT	Ground
9	Rx0+	INPUT	Plus Blue TMDS signal	9	VCC	INPUT	Logic Power +3.3V
10	Rx0-	INPUT	Minus Blue TMDS signal	10	VCC	INPUT	Logic Power +3.3V
11	GND	INPUT	Ground	11	VDD	INPUT	Analog Power +5V
12	RxC+	INPUT	Plus Main clock	12	VDD	INPUT	Analog Power +5V
13	RxC-	INPUT	Minus Main clock	13	VDD	INPUT	Analog Power +5V
14	GND	INPUT	Ground	14	GND	INPUT	Ground
15			NC				
16			NC				
17			NC				
18			NC				
19			NC				
20	GND	INPUT	Ground				



- Note 1 All GND (ground) pins should be connected together and to V_{SS} which should also be connected to the LCD's metal frame.
- Note 2 All V_{DD} (power input) pins should be connected together.

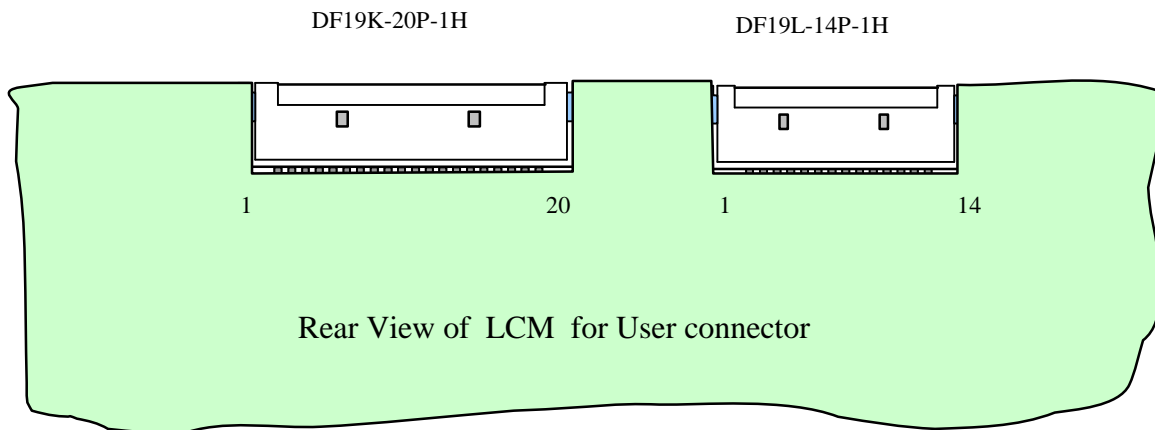

The backlight interface connector is a model BHR-03VS-1, manufactured by JST. The mating connector part number is SM02(8.0)B-BHS-1-TB or equivalent. The pin configuration for the connector is shown in the table below.

Table 4 BACKLIGHT CONNECTOR PIN CONFIGURATION

Pin	Symbol	Description	Notes
1	HV	Lamp power input(High)	1
2	NC	No connection	
3	LV	Lamp power input(Low)	

Note 1: The input power terminal (High) is colored pink.



3.3 Signal Timing Specifications

This is the signal timing required at the input of the TMDS Transmitter. All of the interface signal timing should be satisfied with the following specifications for its proper operation.

Table 5 Timing Table

	ITEM	SYMBOL	MIN.	TYP.	MAX.	UNIT	NOTE
Dclk	Period	t_{CLK}	65	65	65	MHz	
			15.4	15.4	15.4	ns	
Hsync	Period	t_{HP}	1100	1344	1364	t_{CLK}	1
	Width-Active	t_{WH}	8	136	240		1
Vsync	Period	t_{VP}	780	806	830	t_{HP}	
	Frequency	f_V	-	60	70	Hz	
	Width-Active	t_{WV}	2	6	24	t_{HP}	
DE (Data Enable)	Horizontal Back Porch	t_{HBP}	10	160	-	t_{CLK}	1
	Horizontal Front Porch	t_{HFP}	10	24	-		1
	Vertical Back Porch	t_{VBP}	2	29	-	t_{HP}	
	Vertical Front Porch	t_{VFP}	2	3	-		

Note 1: The number of pixels in horizontal timing should keep always even pixels. If the value is odd number times of the unit, display control signal can be asynchronous.



3.4 Signal Timing Waveforms

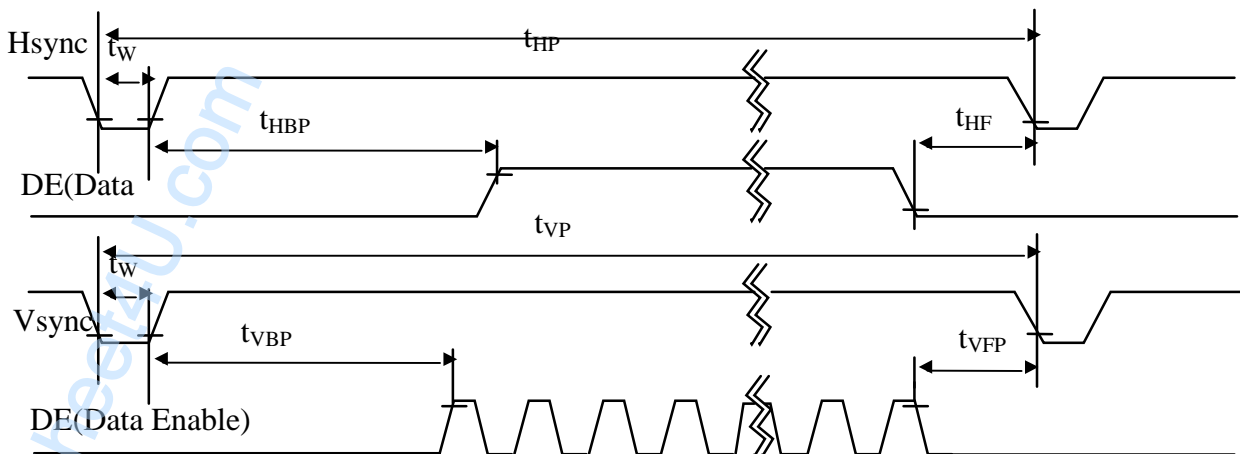
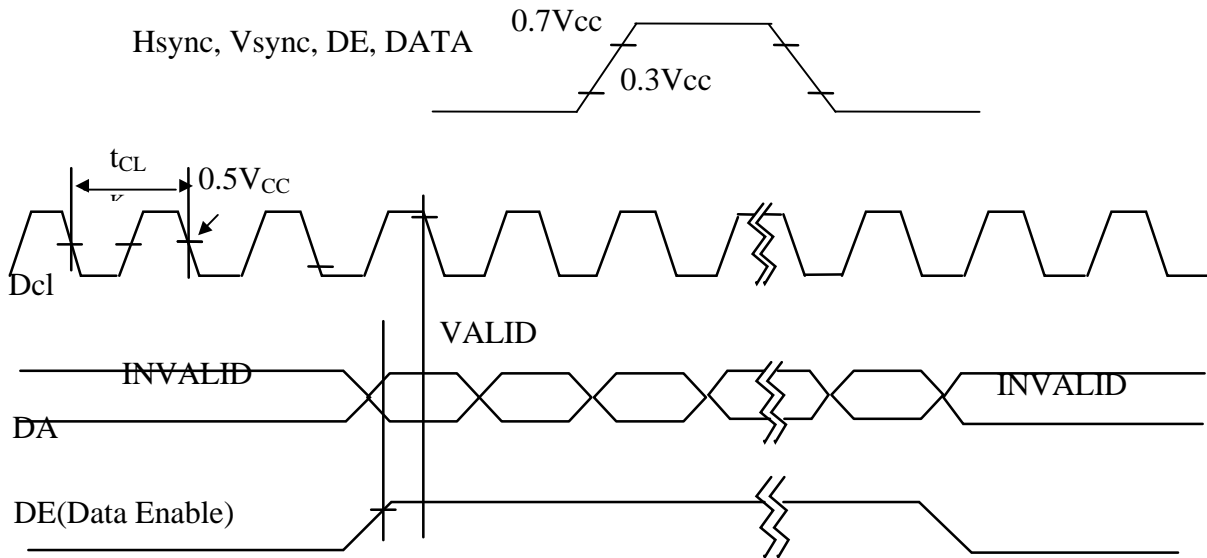

3.5 Color Input Data Reference

The brightness of each primary color (red, green and blue) is based on the 8-bit gray scale data input for the color; the higher the binary input, the brighter the color. The table below provides a reference for color versus data input.

Table 6 COLOR DATA REFERENCE

Color		Input Color Data																							
		Red								Green								Blue							
		MSB				LSB				MSB				LSB				MSB				LSB			
		R7	R6	R5	R4	R3	R2	R1	R0	G7	G6	G5	G4	G3	G2	G1	G0	B7	B6	B5	B4	B3	B2	B1	B0
Basic Colors	Black	0	0	0	0	0	0	0	0	0	0	0	0	0	0	0	0	0	0	0	0	0	0	0	
	Red(255)	1	1	1	1	1	1	1	1	0	0	0	0	0	0	0	0	0	0	0	0	0	0	0	
	Green(255)	0	0	0	0	0	0	0	0	1	1	1	1	1	1	1	1	0	0	0	0	0	0	0	
	Blue(255)	0	0	0	0	0	0	0	0	0	0	0	0	0	0	0	0	1	1	1	1	1	1	1	
	Cyan	0	0	0	0	0	0	0	0	1	1	1	1	1	1	1	1	1	1	1	1	1	1	1	
	Magenta	1	1	1	1	1	1	1	1	0	0	0	0	0	0	0	0	1	1	1	1	1	1	1	
	Yellow	1	1	1	1	1	1	1	1	1	1	1	1	1	1	1	1	0	0	0	0	0	0	0	
	White	1	1	1	1	1	1	1	1	1	1	1	1	1	1	1	1	1	1	1	1	1	1	1	
Red	Red(000) Dark	0	0	0	0	0	0	0	0	0	0	0	0	0	0	0	0	0	0	0	0	0	0		
	Red(001)	0	0	0	0	0	0	0	1	0	0	0	0	0	0	0	0	0	0	0	0	0	0		
	Red(002)	0	0	0	0	0	0	1	0	0	0	0	0	0	0	0	0	0	0	0	0	0	0		
	:	:	:	:	:	:	:	:	:	:	:	:	:	:	:	:	:	:	:	:	:	:	:		
	Red(253)	1	1	1	1	1	1	0	1	0	0	0	0	0	0	0	0	0	0	0	0	0	0		
	Red(254)	1	1	1	1	1	1	1	0	0	0	0	0	0	0	0	0	0	0	0	0	0	0	0	
	Red(255) Bright	1	1	1	1	1	1	1	1	0	0	0	0	0	0	0	0	0	0	0	0	0	0	0	
Green	Green(000)Dark	0	0	0	0	0	0	0	0	0	0	0	0	0	0	0	0	0	0	0	0	0	0		
	Green(001)	0	0	0	0	0	0	0	0	0	0	0	0	0	0	0	1	0	0	0	0	0	0		
	Green(002)	0	0	0	0	0	0	0	0	0	0	0	0	0	0	1	0	0	0	0	0	0	0		
	:	:	:	:	:	:	:	:	:	:	:	:	:	:	:	:	:	:	:	:	:	:	:		
	Green(253)	0	0	0	0	0	0	0	0	1	1	1	1	1	1	0	1	0	0	0	0	0	0		
	Green(254)	0	0	0	0	0	0	0	0	1	1	1	1	1	1	1	0	0	0	0	0	0	0		
	Green(255)Bright	0	0	0	0	0	0	0	0	1	1	1	1	1	1	1	1	0	0	0	0	0	0		
Blue	Blue(000) Dark	0	0	0	0	0	0	0	0	0	0	0	0	0	0	0	0	0	0	0	0	0	0		
	Blue(001)	0	0	0	0	0	0	0	0	0	0	0	0	0	0	0	0	0	0	0	0	0	1		
	Blue(002)	0	0	0	0	0	0	0	0	0	0	0	0	0	0	0	0	0	0	0	0	0	1		
	:	:	:	:	:	:	:	:	:	:	:	:	:	:	:	:	:	:	:	:	:	:	:		
	Blue(253)	0	0	0	0	0	0	0	0	0	0	0	0	0	0	0	1	1	1	1	1	1	0		
	Blue(254)	0	0	0	0	0	0	0	0	0	0	0	0	0	0	0	1	1	1	1	1	1	1		
	Blue(255) Bright	0	0	0	0	0	0	0	0	0	0	0	0	0	0	0	1	1	1	1	1	1	1		



3.6 Power Sequence

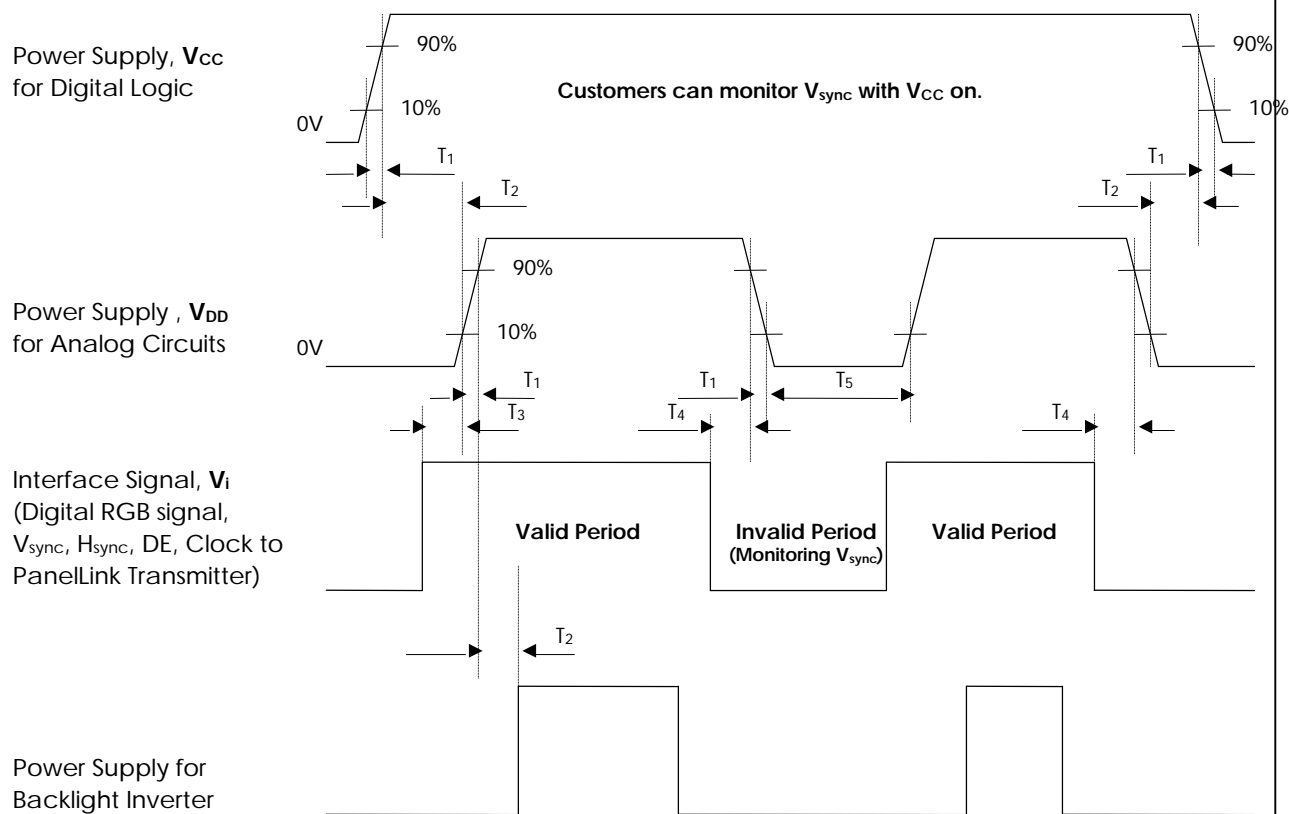

T_1 : 10ns ~ 20 ms (Rise time, Fall time of power supplies)

T_2 : 100 ms (min.)

T_3 : ~50 ms(max.)

T_4 : 100 ms (max.)

T_5 : 1000 ms (min.)

Note 1: Please avoid floating state of interface signal at invalid period.

Note 2: When the interface signal is invalid, be sure to pull down the power supply for LCD V_{CC} to 0V.

Note 3: Lamp power must be turn on after power supply for LCD and interface signal are valid.



3.7 Vdd Dip Condition

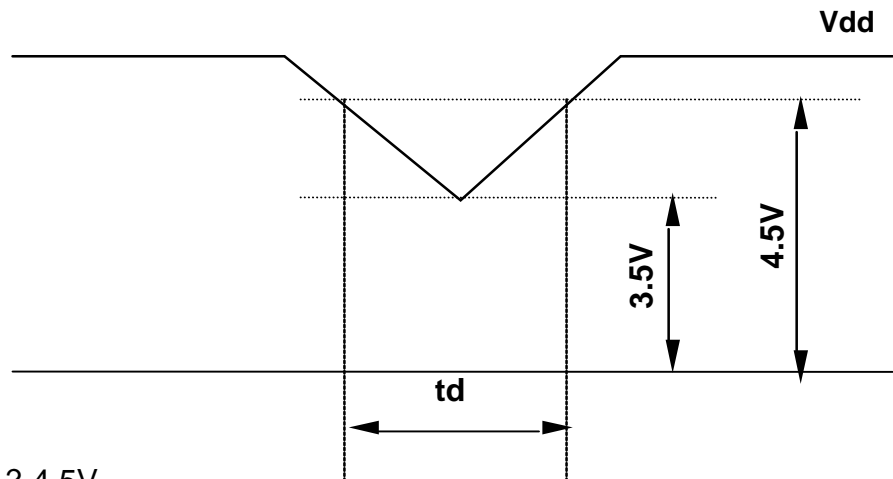

- 1) $3.5V = V_{dd} \geq 4.5V$
 $t_d = 20ms$
- 2) $V_{dd} \geq 5.5V$
Vdd-dip conditions should also follow the Power Up/Down conditions for supply voltage

Note: This phenomenon is caused by row driver IC initialization after power on (1 vertical period) .



4. OPTICAL SPECIFICATIONS

4.1 Optical Specifications

Optical characteristics are determined after the unit has been 'ON' and stable for approximately 30 minutes in a dark environment at 25°. The values specified are at an approximate distance 50cm from the LCD surface at a viewing angle of ? and ? equal to 0° and aperture 1 degree. The test equipment is PhotoResearch Prichard SpectroRadiometer Model 1980B-SC or equivalent. The input signal voltage and timing specification are V_{DD} of 5.0Vdc, and VESA XGA @60Hz respectively. The input current of backlight is 8mA ($F_{BL} = 50\text{KHz}$) at the ground terminals.

Table 7 OPTICAL CHARACTERISTICS

Parameter	Symbol	Values			Units	Notes
		Min.	Typ.	Max.		
Contrast Ratio	CR	250	300	-		1
Surface Luminance, white	SB _{WH}	200	250	-	cd/m ²	2
Luminance Variation	SB _V	-	-	30	%	3
Luminance Uniformity(TCO'99)	L _R			1.7		4
Response Time	Tr		45	60	ms	5
Rise Time	Tr _R	-	10	15		
Delay Time	Tr _D	-	35	45		
CIE Color Coordinates						
Red	x _R	0.610	0.640	0.670		
	y _R	0.310	0.340	0.370		
Green	x _G	0.275	0.305	0.335		
	y _G	0.580	0.610	0.640		
Blue	x _B	0.110	0.140	0.170		
	y _B	0.085	0.115	0.145		
White	x _W	0.283	0.313	0.343		
	y _W	0.299	0.329	0.359		
Viewing Angle by CR ? 5					degree,	6
x axis, right (F =0°)		70	75	-	°	
x axis, left(F =180°)		70	75	-		
y axis, up(F =90°)		50	55	-		
y axis, down (F =270°)		55	60	-		
Half luminance Angle						7
x axis, right (F =0°)		-	45	-		
x axis, left(F =180°)		-	45	-		
y axis, up(F =90°)		-	30	-		
y axis, down (F =270°)		-	30	-		
Cross talk					%	8
Vertical				2.5		
Horizontal				2.5		
Gray Scale		-	-	-		9
Gamma Value			2.40			



Note 1: Contrast Ratio (CR) is defined mathematically as:

$$\frac{\text{(Surface Luminance with all white pixels)}}{\text{(Surface Luminance with all black pixels)}}$$

Contrast ratio shall be measured at the center of the display (Location 1).

Note 2: The Luminance is The average luminance value at 5 locations with full white screen. The 5 locations are the location number 1, 2 3, 4, 5 at the picture of note 3.

Note 3: The variation in surface luminance, SB_v is defined as:

$$\frac{\text{Maximum } (B_1, B_2, \dots, B_{13}) - \text{Minimum } (B_1, B_2, \dots, B_{13})}{\text{Average } (B_1, B_2, \dots, B_5)} \times 100(\%)$$

Where B1 to B13 are the luminance with all pixels displaying white at 13 locations.

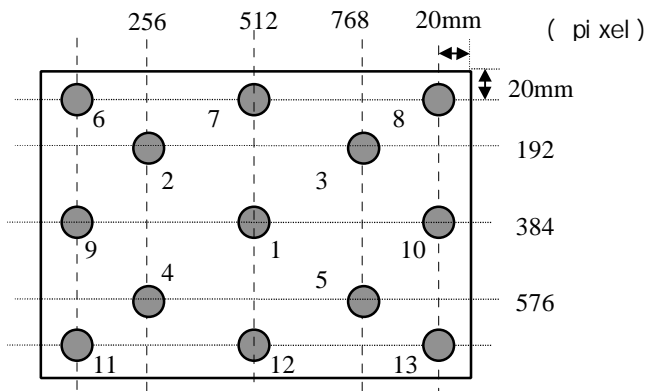

Note 4: TCO' 99 Certification Requirements and test methods for environmental labelling of Displays [Flat] Report No.2 (X1.5.2 Luminance Uniformity)

$$L_R = ((L_{\max,+30\text{deg.}} / L_{\min,+30\text{deg.}}) + (L_{\max,-30\text{deg.}} / L_{\min,-30\text{deg.}})) / 2$$

Note 5: The response time is defined as the following figure and shall be measured by switching the input signal for "black" and "white".

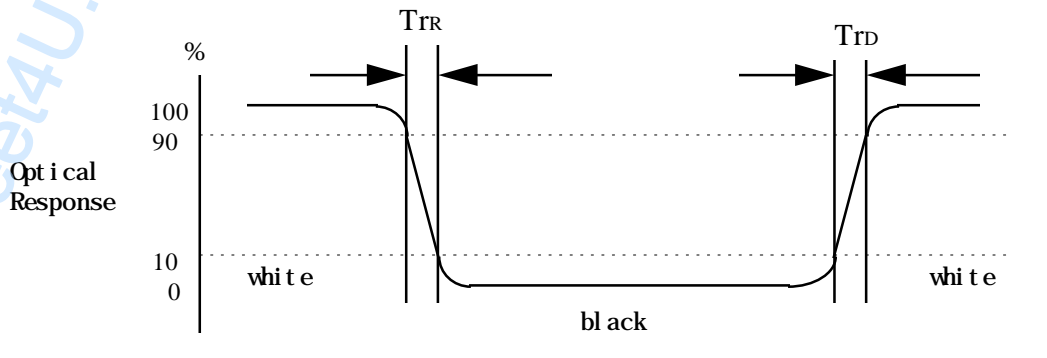

Note 6: Viewing angle is the angle at which the contrast ratio is greater than 5.

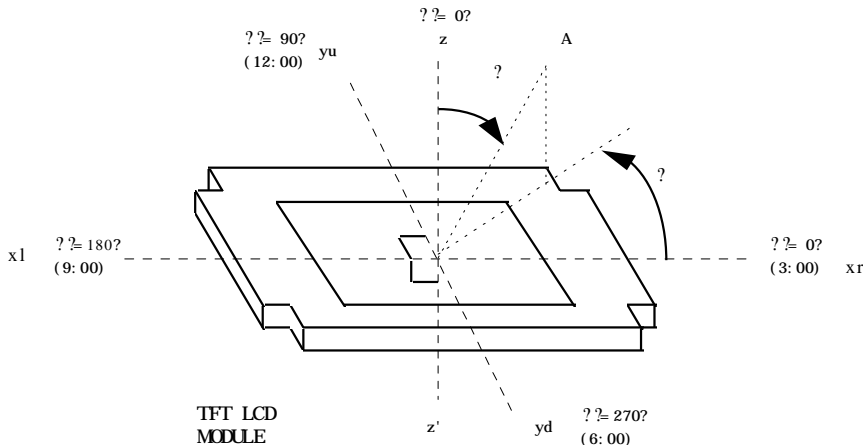

Note 7: Half Luminance Angles Half Luminance Angles are defined as the up, down, left, and right angular boundaries at which the luminance value is 50% of the luminance value measured on-axis. Measurements shall be done at the center of the display area (Location 1) with a full White image.

Note 8: Cross talk shall be measured at one point.

$$\text{Vertical Crosstalk Ratio} = 100 \times \frac{\text{Luminance at Position } P_a - \text{Luminance at Position } P_b}{\text{Luminance at Position } P_a}$$

$$\text{Horizontal Crosstalk Ratio} = 100 \times \frac{\text{Luminance at Position } P_c - \text{Luminance at Position } P_d}{\text{Luminance at Position } P_c}$$

Pattern A

Mid-gray : Gs(S)=127
Rectangular:Gs(S)=0

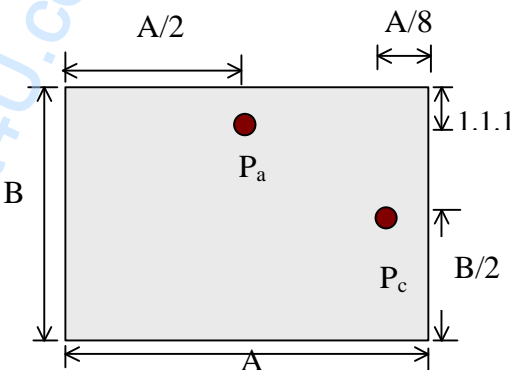

Pattern B

(Background:Gs(S)=127,

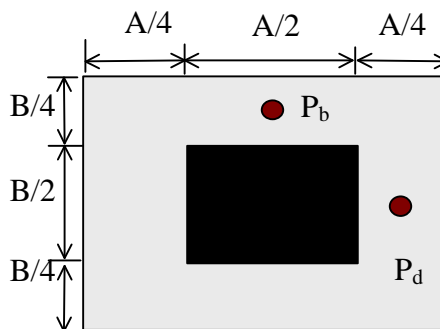

Note 9: Gray Scale

n	Gs(S)	Relative Brightness (%)			Remark
		Min.	Typ.	Max.	
0	0	-	0.32	0.69	
1	31	-	0.78	1.55	
2	63	1.3	3.26	5.52	
3	95	5.1	8.7	12.5	
4	127	12.0	17.5	24.0	
5	159	23.3	31.9	41.5	
6	191	39.5	51.7	62.0	
7	223	61.5	72.5	84.5	
8	255	100	100	100	



5. MECHANICAL CHARACTERISTICS

The contents provide general mechanical characteristics for the model LM151X3-B3AP. In addition, the figures in the next page are detailed mechanical drawings of the LCD.

Outside dimensions:

Horizontal	352.0
Vertical	263.5
Depth	16.0

Bezel area:

Horizontal	311.2
Vertical	234.4

Active Display area:

Horizontal	307.2 mm
Vertical	230.4 mm

Weight (approximate):

1500g (typ), 1600g(max)

Surface Treatment:

Hard coating 3H.

Anti-glare treatment of the front polarizer



< FRONT VIEW >

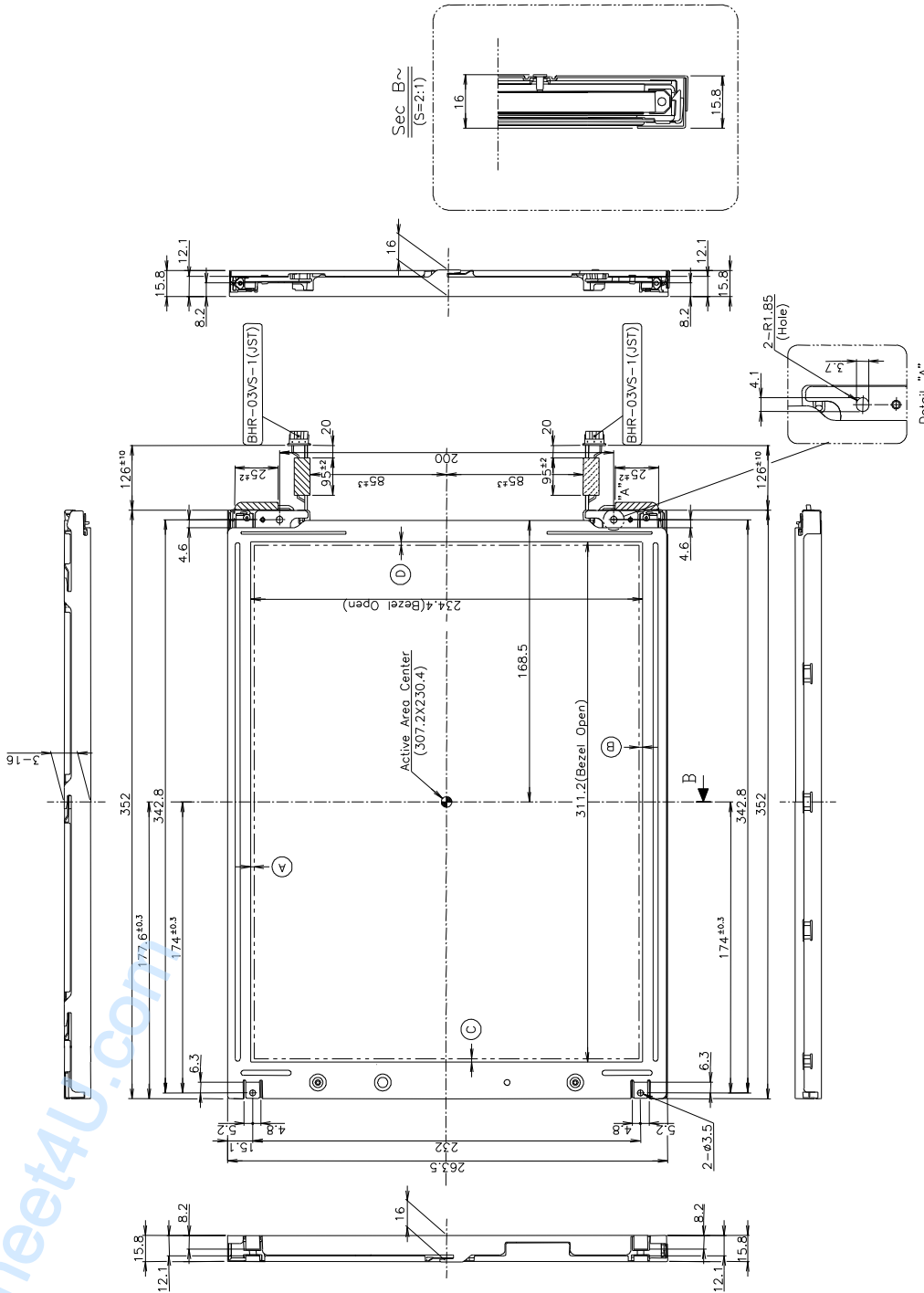

< REAR VIEW >

6.

NOTES

1. Unspecified tolerances to be ± 0.5
2. This drawing is only preliminary data and can be changed without previous notice
3. Gap between Top case and Glass is $0.2(+0.5/-0.2)$
4. Tilt and partial disposition tolerance of display area are as follow
 - 1) Y-Direction : $|A-B| \leq 1.0$
 - 2) X-Direction : $|C-D| \leq 1.0$

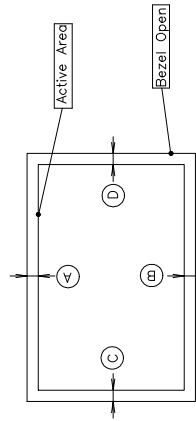

5. The same shape is same demension.

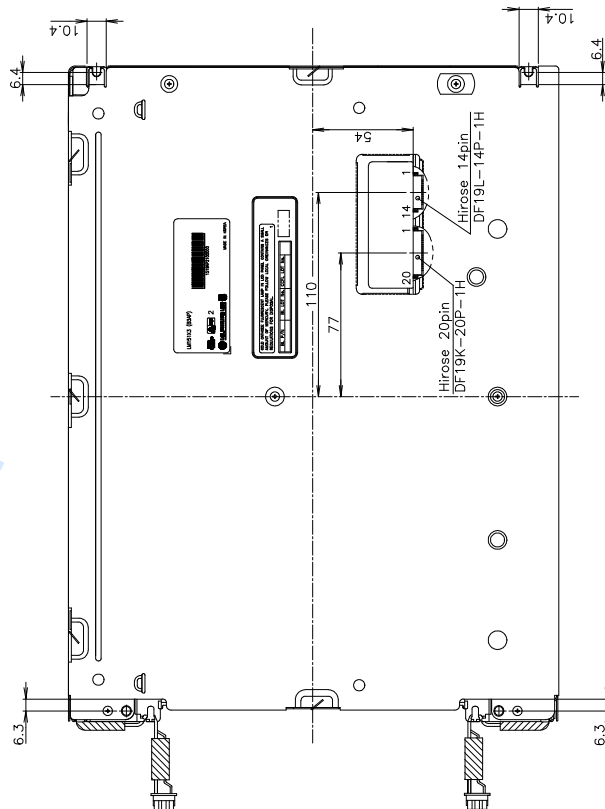

*. When a P3 Panel is applied, a "2" mark on the model name label is deleted.

www.DataSheet4U.com



6. RELIABILITY

Environment test condition

No.	Test Item	Conditions
1	High temperature storage test	Ta = 60° 240h
2	Low temperature storage test	Ta = -20° 240h
3	High temperature operation test	Ta = 50° 50%RH 240h
4	Low temperature operation test	Ta = 0° 240h
5	Vibration test (non-operating)	Wave form: random Vibration level: 1.0G RMS Bandwidth: 10 - 500Hz Duration: X,Y,Z, 20 min One time each direction
6	Shock test (non-operating)	Shock level: 120G Waveform: half sine wave, 2ms Direction: ±X, ±Y, ±Z One time each direction
7	Altitude	Storage :40,000 ft

Result Evaluation Criteria

There should be no change which might affect the practical display function when the display quality test is conducted under normal operating condition.

- ON/OFF Cycle: The display module will be capable of being operated over 24,000 ON/OFF cycles (Lamp power & Vcc ON/OFF)



7. 7. INTERNATIONAL STANDARDS

7.1 Safety

- a) UL 1950 Third Edition, Underwriters Laboratories, Inc. Jan. 28, 1995.
Standard for Safety of Information Technology Equipment Including Electrical Business Equipment.
- b) CAN/CSA C22.2 No. 950-95 Third Edition, Canadian Standards Association, Jan. 28, 1995.
Standard for Safety of Information Technology Equipment Including Electrical Business Equipment.
- c) EN 60950 : 1992 + A1 : 1993 + A2 : 1993 + A3 : 1995 + A4 : 1997 + A11 : 1997
EC 950 : 1991 + A1 : 1992 + A2 : 1993 + A3 : 1995 + A4 : 1996
European Committee for Electrotechnical Standardization (CENELEC)
EUROPEAN STANDARD for Safety of Information Technology Equipment Including Electrical Business Equipment.

8. PACKING

8.1 Designation of Lot Mark

a) Lot Mark

A	B	C	D	E	F	G	H	I	J	K	L	M
---	---	---	---	---	---	---	---	---	---	---	---	---

A, B, C: Inch CODE
D: YEAR
E: MONTH
F,G: Panel Code
H: Assembly Code
I, J, K, L,M: SERIAL NO.

Note 1: YEAR

YEAR	98	99	2000	2001	2002	2003	2004	2005	2006	2007	2008
Mark	8	9	0	1	2	3	4	5	6	7	8

2. MONTH

MONTH	Jan	Feb.	Mar.	Apr.	May	Jun.	Jun.	Aug.	Sep.	Oct.	Nov.	Dec.
Mark	1	2	3	4	5	6	7	8	9	A	B	C



b) Location of Lot Mark

Serial No. is printed on the label. The label is attached to the backside of the LCD module. This is subject to change without prior notice.

8.2 Packing Form

- a) Package quantity in one box: 8 pcs
- b) Box Size: 365mm x 345 mm x 449 mm

9. PRECAUTIONS

- You must mount a module using holes arranged in four corners or four sides.
- You should consider the mounting structure so that uneven force (ex. twisted stress) is not applied to the module. And the case on which a module is mounted should have sufficient strength so that external force is not transmitted directly to the module.
- Please attach a transparent protective plate to the surface in order to protect the polarizer. Transparent protective plate should have sufficient strength in order to resist external force.
- You should adopt radiation structure to satisfy the temperature specification.
- Acetic acid type and chlorine type materials for the cover case are not desirable because the former generates corrosive gas of attacking the polarizer at high temperature and the latter causes circuit break by electro-chemical reaction.
- Do not touch, push or rub the exposed polarizers with glass, tweezers or anything harder than HB pencil lead. Please do not rub with dust clothes with chemical treatment. Do not touch the surface of polarizer for bare hand or greasy cloth. (Some cosmetics are detrimental to the polarizer.)
- When the surface becomes dusty, please wipe gently with absorbent cotton or other soft materials like chamois soaked with petroleum benzene. Normal-hexane is recommended for cleaning the adhesives used to attach front / rear polarizers. Do not use acetone, toluen and alcohol because they cause chemical damage to the polarizer.
- Wipe off saliva or water drops as soon as possible. Their long time contact with polarizer causes deformations and color fading.
- Do not open the case because inside circuits do not have sufficient strength.

9.1 OPERATING PRECAUTIONS

- The spike noise causes the mis-operation of circuits. It should be lower than following voltage: $V = ? 200\text{mV}$ (Over and under shoot voltage).
- Response time depends on the temperature (in lower temperature, it becomes longer) .



- Brightness depends on the temperature (in lower temperature, it becomes lower). In lower temperature, response time (required time that brightness is stable after turned on) becomes longer.
- Be careful for condensation at sudden temperature change. Condensation makes damage to polarizer or electrical contacted parts. And after fading condensation, smear or spot will occur.
- When fixed patterns are displayed for a long time, remnant image is likely to occur.
- A module has high frequency circuit. If you need to shield the electromagnetic noise, please do in yours. When a Back-light unit is operating, it sounds. If you need to shield the noise, please do in yours.

9.2 ELECTROSTATIC DISCHARGE CONTROL

Since a module is composed of electronic circuits, it is not strong to electrostatic discharge. Make certain that treatment persons are connected to ground through wrist band etc . And don't touch interface pin directly.

9.3 PRECAUTIONS FOR STRONG LIGHT EXPOSURE

Strong light exposure causes degradation of polarizer and color filter.

9.4 STORAGE

- When storing modules as spares for a long time, the following precautions are necessary.
- Store them in a dark place. Do not expose the module to sunlight or fluorescent light. Keep the temperature between 5° and 35° at normal humidity.
- The polarizer surface should not come in contact with any other object. It is recommended that they be stored in the container in which they were shipped.

9.5 HANDLING PRECAUTIONS FOR PROTECTION FILM

- When the protection film is peeled off, static electricity is generated between the film and polarizer. This should be peeled off slowly and carefully by people who are electrically grounded and with well ion- blown equipment or in such a condition, etc.
- The protection film is attached to the polarizer with a small amount of glue. If some stress is applied to rub the protection film against the polarizer during the time you peel off the film, the glue is apt to remain on the polarizer. Please carefully peel off the protection film without rubbing it against the polarizer.
- When the module with protection film attached is stored for a long time, sometimes there remains a very small amount of glue still on the polarizer after the protection film is peeled off.
- You can remove the glue easily. When the glue remains on the polarizer surface or its vestige is recognized, please wipe them off with absorbent cotton waste or other soft material like chamois soaked with normal-hexane.

